



| | |
|------------------|---|
| Title | Effects of tunicamycin on sexual reproduction in heterothallic strains of <i>Closterium</i> |
| Author(s) | KATO, Atsushi; SASAKI, Kimiko |
| Citation | Journal of the Faculty of Science, Hokkaido University. Series 5, Botany, 13(1), 1-6 |
| Issue Date | 1983 |
| Doc URL | https://hdl.handle.net/2115/26392 |
| Type | departmental bulletin paper |
| File Information | 13(1)_P1-6.pdf |



Effects of tunicamycin on sexual reproduction in heterothallic strains of *Closterium*

Atsushi KATO* and Kimiko SASAKI

The effect of tunicamycin on the sexual reproduction of heterothallic strains of *Closterium peracerosum-strigosum-littorale*, KAS-4-29 (mating type-minus) and KAS-4-30 (mating type-plus), was investigated. At a concentration of 0.5 $\mu\text{g/ml}$ of liquid mating medium, tunicamycin inhibited the sexual interaction between the opposite mating types almost completely, but the cell division about 45%. When the mating type-minus cells were treated with 0.5 μg tunicamycin/ml agar-mating medium, the ability to produce protoplast-releasing substance which induces protoplasts from the mating type-plus cells was lost. When the mating type-plus cells were treated as the same as above, the response to the substance disappeared significantly. These results suggest that the protoplast-releasing substance is a glycoprotein.

Heterothallic strains of *Closterium peracerosum-strigosum-littorale*, KAS-4-29 (mating type-minus, mt^-) and KAS-4-30 (mating type-plus, mt^+), seemed to be convenient materials for the study of mating process which is controlled by changing culture conditions. The morphological and biochemical properties of the cells change synchronously during the process (KATO *et al.* 1981). When the mt^- - and mt^+ -cells were mixed in a nitrogen-depleted mating medium, they were sexually activated and form zygote within 60 hr. During the process, most cells paired and a few of the mt^+ -cells unpaired: protoplasts were released from the paired cells and fused, whereas they were also released from the unpaired mt^+ -cells and yet soon disrupted. A factor which was produced by the mt^- -cells and made the mt^+ -gametangial cells to produce the protoplasts was presumed to be a glycoprotein (KATO *et al.* 1981). In this connection, effect of tunicamycin, an inhibitor of glycosylation of proteins containing asparagine linked sugar chains, on the gametic differentiation of *Chlamydomonas reinhardtii* has been studied (MATSUDA *et al.* 1981).

In this paper, we report that tunicamycin inhibits the sexual cell division and sexual activation of the mt^- and mt^+ -cells of *Closterium* and discuss on the involvement of some mating-specific glycoproteins in cell-cell recognition and interaction during the sexual reproduction process.

* Present address: The Institute of Nippon Biological Science, 2221-1, Shinmachi, Ome, Tokyo 198.

Materials and Methods

Algal materials and culture conditions

Closterium peracerosum-strigosum littorale, KAS-4-29 (mating type-minus, mt^-) and KAS-4-30 (mating type-plus, mt^+) were used in this study. Cells were grown vegetatively and sexual reproduction was induced as described previously (ICHIMURA 1971, KATO *et al.* 1981).

Treatment with tunicamycin

To see involvement of glycoprotein in mating process, equal number of

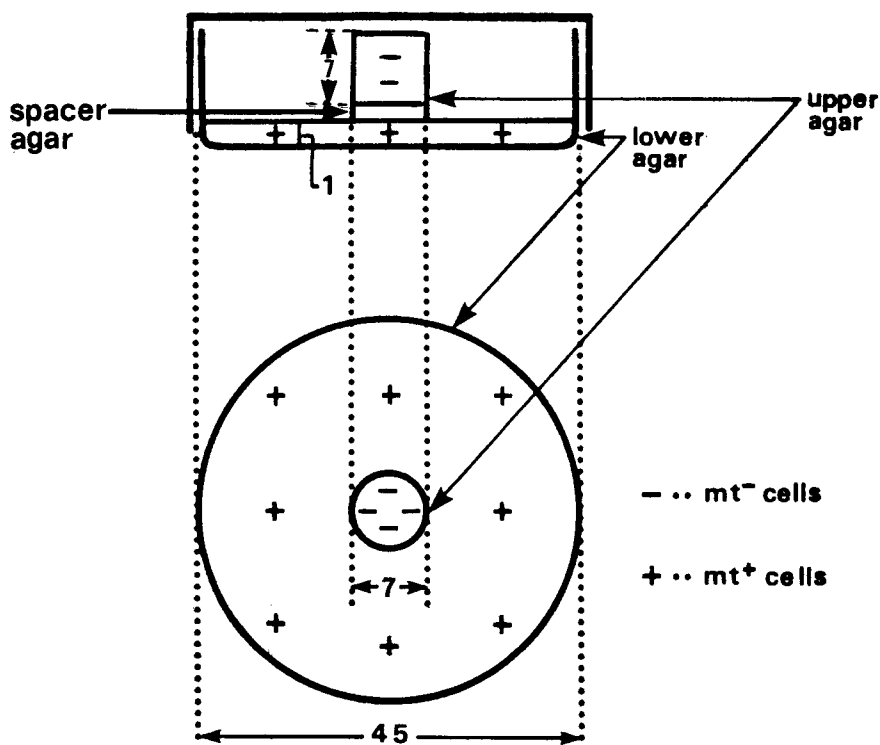

Fig. 1. Illustration of procedures for estimation of effect of PRS on the mt^+ -cells. Agar disk (7 mm diameter and 3 or 7 mm height) containing the mt^- -cells, "upper agar", was placed on agar plate (1 mm thickness) containing the mt^+ -cells, "lower agar", in a Petri dish (45 mm diameter). "Spacer agar" (1 mm thickness) was placed between the agar disk and agar plate to prevent direct contact between the mt^- - and mt^+ -cells. By the procedure, PRS excreted from the mt^- -cells was diffused from "upper agar" to "lower agar" and reached to the mt^+ -cells. As an indicator of the PRS effect, protoplast production from the mt^+ -cells was used.

the mt^- and mt^+ -cells, 3×10^3 cells/ml, were mixed and cultured in liquid mating medium with or without tunicamycin, 0.1 to 100 $\mu\text{g/ml}$, and the degrees of cell division and sexual activation were measured. The sexual activity was expressed as the percentage of sexually activated cells, zygotes and protoplast-releasing mt^+ -cells, in the total cells (KATO *et al.* 1981). Using tunicamycin, the sexual activity was expressed as % of control without the drug. Under the mating conditions, mating-specific "protoplasts-releasing substance (PRS)" was produced from the mt^- -cells and interacted with the mt^+ -cells (KATO *et al.* 1981). To determine whether PRS is glycoprotein, either the mt^- or mt^+ -cells, 3×10^3 cells/ml, were treated with tunicamycin (0.5 or 1.0 $\mu\text{g/ml}$ of 1% (disk) or 0.6% (plate) agar-containing mating medium) according to the procedure illustrated in Fig. 1. Sexual activity with the drug was expressed as % of control without the drug.

Chemicals

Tunicamycin was purchased from Sigma Chemical Co.

Results and Discussion

In liquid mating medium, sexual activation (formations of paired cells, zygotes, and protoplasts from mt^+ -cells) was inhibited completely with 0.5 $\mu\text{g/ml}$ tunicamycin, and sexual cell division only about 53% (Table 1). These results indicate that cell-cell recognition and adhesion are mediated by mating-

TABLE 1. Effects of tunicamycin on the sexual cell division and sexual activation of *Closterium* in liquid mating medium

| Exp. (No.) | Tunicamycin ($\mu\text{g/ml}$) | Cell division (% of control) | Sexual activity | |
|---------------|-------------------------------------|---------------------------------|------------------|----------------|
| | | | (%) ^a | (% of control) |
| 1 | 0 | 100 | 74 | 100 |
| | 0.1 | 65 | 69 | 93 |
| | 0.5 | 53 | 1.2 | 1.6 |
| | 1.0 | 12 | 0 | 0 |
| 2 | 0 | 100 | 72 | 100 |
| | 1.0 | 21 | 0 | 0 |
| | 10.0 | 17 | 0 | 0 |
| | 100.0 | 0 | 0 | 0 |

Tunicamycin was added to the mixture of the mt^- - and mt^+ -cells (3×10^3 cells/ml). Cell number and sexually activated cells were measured after 60 hr of the mating culture. Cells divided once. The values without the drug was used as control.

a Percentage of sexually activated cells in total cells.

specific glycoprotein. A factor produced and excreted from the mt^- cells, which acted on the mt^+ -cells so as to let them release protoplasts and was designated as PRS (protoplast-releasing substance), was reported to seem likely to be a glycoprotein having molecular weight of 200 to 500 kdal (KATO *et al.* 1981). Therefore, it was proved by the experimental results with tunicamycin that the above presumption was not unreasonable.

When the mt^- -cells were treated with 0.5 $\mu\text{g/ml}$ tunicamycin in agar disk containing mating medium, sexual activation of the mt^+ -cells (release and disruption of protoplasts) was completely inhibited, whereas in the mt^+ -cells treated by the same procedure, the activation was not inhibited completely (Table 2). These results suggest that PRS is a glycoprotein and produced in the mt^- -cells only under the mating conditions, and that receptor for PRS on the mt^+ -cells is a glycoprotein. PRS-synthesizing system in the mt^- -cells seemed to be more sensitive to tunicamycin than the receptor-synthesizing system which has not been identified in the mt^+ -cells. In *Clamydomonas reinhardtii*, it has been reported that the gametic flagellar membrane of the mt^+ -cells may consist of glycoprotein with tunicamycin-sensitive chain, the half life of which is about 6 hr (MATSUDA *et al.* 1981). In the mt^+ -cells of *Closterium* used here, receptor of PRS seemed to be present in an inactive state for mating unless they associate with PRS. The receptor has not been characterized yet. As the result of receptor-PRS interaction,

TABLE 2. Effects of tunicamycin on the sexual activation of *Closterium* gametes in agar containing mating medium

| Mating time (hr) | Sexual activity ^a | | | | |
|---------------------|----------------------------------|-------|-------|-------|----------------------|
| | Tunicamycin ($\mu\text{g/ml}$) | | | | |
| | 0/0 | 0/0.5 | 0/1.0 | 0.5/0 | 0.5/0.5 ^b |
| 24 | 0 | 0 | 0 | 0 | 0 |
| 32 | 6 | 0 | 0 | 0 | 0 |
| 48 | 6 | 0 | 0 | 0 | 0 |
| 50 | 20 | 5 | 0 | 0 | 0 |
| 52 | 35 | 7 | 0 | 0 | 0 |
| 56 | 65 | 10 | 0 | 0 | 0 |
| 58 | 65 | 10 | 0 | 0 | 0 |
| 72 | 65 | 10 | 0 | 0 | 0 |

a Sexually activated mt^+ -cells in "lower agar" were counted.

b Numerator and denominator represent tunicamycin contents in "upper agar (mt^- -cells)" and "lower agar (mt^+ -cells)", respectively. Each of the values in the Table was average of three or four assays.

protoplast-releasing system may be activated and induce mating-specific cell-wall lytic enzyme. In paired cells, the enzyme degrades the cell walls of the mt^- - and mt^+ -cells, thereby their protoplasts are released and fused to form zygospore. The enzyme seemed to be synthesized in the mt^+ -cells by the contact with PRS. Since the mt^- -cells could not release their protoplasts without the direct contact with the activated mt^+ -cells (KATO *et al.* 1981), the enzyme may be able to act on the mt^- -cells after the direct contact with the mt^+ -cells. In unpaired mt^+ -cells, the enzyme may act on themselves to release and degrade the protoplasts. In *Clamydomonas reinhardtii*, it has been reported that cell-wall lytic enzyme is induced in mt^+ -cells by the contact with mt^- -cell flagellar substance (MATSUDA *et al.* 1978; TAMAKI *et al.* 1981). Induction of cell-wall lytic enzyme in the mt^+ -cells by the contact with mt^- -cell substance may be mediated by a similar way as in *Clamydomonas* and *Closterium*.

Tunicamycin (TAKATSUKI *et al.* 1971) has been used as a specific inhibitor of the glycosylation of proteins which have important role in biological processes. Important role of glycoprotein in sexual interactions in yeast (MANNEY *et al.* 1981) and in *Volvox* (KOCHEK 1981) has been reported.

Further experiments on isolation, purification, and characterization of PRS and PRS-receptor in *Closterium* should be need to elucidate the mechanism of cell-cell recognition and interaction for the mating.

We are grateful to Drs. T. Ichimura and M. M. Watanabe for supplying the algal materials and for their valuable advices.

References

- HAMADA, J. 1978. Studies on several environmental factors for zygote formation and germination of *Closterium ehrenbergii*. Bot. Mag. Tokyo **91**: 173-180.
- HOGETSU, T. and YOKOYAMA, M. 1979. Light, a nitrogen-depleted medium and cell-cell interaction in the conjugation process of *Closterium strigosum* Meneghini. Plant & Cell Physiol. **20**: 811-817.
- ICHIMURA, T. 1971. Sexual cell division and conjugation-papilla formation in sexual reproduction of *Closterium strigosum*. In Proc. 7th Internat. Seaweed Symp. Sapporo, pp. 208-214.
- KATO, A., OBOKATA, J. and SASAKI, K. 1981. Mating type interaction in *Closterium peracerosum-strigosum-littorale*: Mating induced protoplast release. Plant & Cell Physiol. **22**: 1215-1222.
- KOCHEK, G. 1981. Sexual pheromones in *Volvox* development. In: D. H. O'DAY and P. A. HORGAN, ed., Sexual Interaction in Eukaryotic Microbes. p. 73-93. Academic Press, New York.
- MANNEY, T. R., DUNTZE, W. and BETZ, R. 1981. The isolation, characterization,

- and physiological effects of the *Saccharomyces cerevisiae* sex pheromones. In: D. H. O'DAY and P. A. HORGAN, ed., Sexual Interaction in Eukaryotic Microbes. p. 21-51. Academic Press, New York.
- MATSUDA, Y. 1980. Occurrence of wall-less cells during synchronous gametogenesis in *Chlamydomonas reinhardtii*. Plant & Cell Physiol. **21**: 1339-1342.
- MATSUDA, Y., SAKAMOTO, K., MIZUOCHI, T., KOBATA, A., TAMURA, G. and TSUBO, Y. 1981. Mating type specific inhibition of gametic differentiation of *Chlamydomonas reinhardtii* by tunicamycin. Plant & Cell Physiol. **22**: 1607-1611.
- MATSUDA, Y., TAMAKI, S. and TSUBO, Y. 1978. Mating type specific induction of cell wall lytic factor by agglutination of gametes in *Chlamydomonas reinhardtii*. Plant & Cell Physiol. **19**: 1253-1261.
- TAMAKI, S., MATSUDA, Y. and TSUBO, Y. 1981. The isolation and properties of the lytic enzyme of the cell wall released by mating gametes of *Chlamydomonas reinhardtii*. Plant & Cell Physiol. **22**: 127-133.
- TAKATSUKI, A., ARIMA, K. and TAMURA, G. 1971. Tunicamycin, a new antibiotic I. Isolation and characterization of tunicamycin. J. Antibiot. **24**: 215-223.