



# HOKKAIDO UNIVERSITY

Title	Electrophysiological Studies on the Mechanism of Effects of Anaesthetics on the Isolated Frog Muscle Fibre (With 10 Text-figures)
Author(s)	YAMAGUCHI, Tsuneo
Citation	北海道大學理學部紀要, 14(4), 522-535
Issue Date	1961-12
Doc URL	<a href="https://hdl.handle.net/2115/27332">https://hdl.handle.net/2115/27332</a>
Type	departmental bulletin paper
File Information	14(4)_P522-535.pdf



# Electrophysiological Studies on the Mechanism of Effects of Anaesthetics on the Isolated Frog Muscle Fibre<sup>1)</sup>

By  
**Tsuneo Yamaguchi**

Zoological Institute, Faculty of Science, Hokkaido University  
(With 10 Text-figures)

It is well known that anaesthetics depress the excitability of the living cell (Overton 1901, Lillie 1923, and many others). But we have very little exact information on what is involved in this depressing mechanism. Recently Thesleff (1956), using the frog muscle fibre, suggested that the depressant effect on the excitability of the cell membrane may be due to a reduction of the selective sodium conductance in the cell membrane; and Shanes *et al.* (1958), using the squid giant axon, have brought forward considerable evidence to support Thesleff's suggestion. This suggestion, however, is still insufficient to explain in full the effects of anaesthetics. Because, as has already been pointed out by Yamaguchi (1957), anaesthetics have not only the property of a depressant, but also that of a stimulant for excitable cells.

In the present paper, it is attempted, by means of electrophysiological technique, to obtain conclusive experimental evidences for the effects of anaesthetics on the frog muscle fibres, and to establish a more complete concept of "anaesthesia".

## Material and methods

*Preparation*: In order to investigate directly the chemical effect on living material, the isolated single cell is the most convenient and simple material. All the experiments were made with single muscle fibres isolated free from injury over the entire length, from *musculus biceps*, *m. semitendinosus*, or *m. rectus femoralis* of the hind legs of the frog, *Rana japonica*. The isolated fibres were mounted in a specially designed chamber for extracellular recording (Fig. 1) and in the usual saline bath for intracellular recording in which the fibre was held horizontally.

*Intracellular recording*: Intracellular recordings of the resting and action membrane potential of muscle fibres were made with a glass capillary microelectrode with the tip always smaller than  $1.0\mu$  in diameter. It was filled with 3 M KCl solution and had a direct current resistance of 10–40 megohms. The microelectrode was connected with a cathod follower, and the shank of microelectrode was made shorter than 5–6 cm in order to reduce the input capacitance. The rise time of a square wave pulse through the

---

1) Contribution No. 518 from the Zoological Institute, Faculty of Science, Hokkaido University, Sapporo, Japan. The cost of this work has been defrayed in part from a Governmental Grant (to Prof. M. Tamagishi) in Aid for Fundamental Scientific Research.  
*Jour. Fac. Sci. Hokkaido Univ. Ser. VI, Zool., 14, 1961.*

electrode and amplifier system was about 100–150  $\mu$ sec. Therefore, the error in the action potential recording, caused by capacitive shunting, was reasonably negligible in the present experimental accuracy. The indifferent electrode was of Ag-AgCl type, having a considerable area, dipped in the Ringer's fluid bath. The intracellular electrode was easily dislodged from the fibre by contraction, especially during a twitch. Therefore, it was necessary to stretch the fibre to a suitable extent.

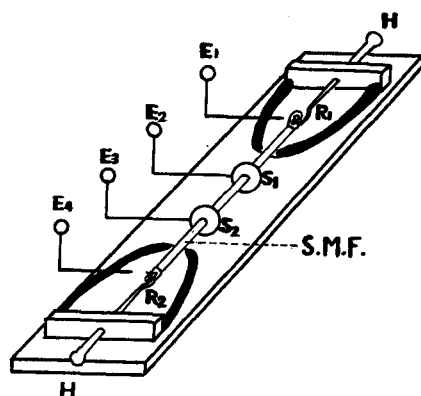

Fig. 1. The electrodes assembly for extracellular recording.  $E_1$ ,  $E_2$ ,  $E_3$ ,  $E_4$ : Ag-AgCl type non-polarizable electrode,  $S_1$ ,  $S_2$ ; silver ring in which thin layer of Ringer's solution or anaesthetic solution is filled,  $R_1$ ,  $R_2$ ; Ringer's solution or anaesthetic solution bath, H: glass hook, S.M.F.; single muscle fibre.

*Extracellular recording:* The experimental chamber for extracellular recording consisted of four movable fluid electrodes ( $R_1$ ,  $R_2$ ,  $S_1$  and  $S_2$ ) by air gaps through which the fibre passed. Especially,  $S_1$  and  $S_2$  consisted of thin silver rings (2 mm in diameter) in which a thin layer of Ringer's solution or anaesthetic solution was placed and maintained by surface tension. All the fluid electrodes were connected to the recording or stimulating electrodes of Ag-AgCl type ( $E_1$ ,  $E_2$ ,  $E_3$  and  $E_4$ ). Recording of the action potential from the fibre was made from a pair of electrode ( $E_1$  and  $E_2$ ) and stimulation of the fibre was applied between another pair of electrode ( $E_3$  and  $E_4$ ). For recording the action potential, a direct-coupled amplifier was employed, the potential change being displayed on one of beams of the oscilloscope. In order to prevent the fibre from drying out, the muscle chamber was completely covered and moistened with the Ringer's solution. The excitability of the fibre could remain constant for 30 minutes at least, with a stimulation frequency of less than two per minute.

*Stimulation:* The rectangular stimulating pulses were applied by a pair of electrodes, through an isolating circuit from the earth to reduce the stimulus artifact on the record. The pulse duration could be varied between 0.1–2.0 msec.

*Microinjection:* Glass micropipettes were employed and their tip diameters were 0.5–1.0  $\mu$ . The micropipette was immersed in the solution to be used for microinjection, the solution entered the pipette tip by capillarity alone and then the pipette was

completely filled with the solution from another glass pipette with a long thin shank. The solution was injected into the fibre from the micropipette connected to a syringe, the pressure (up to 5 atmospheres) being exerted by a micrometer screw. The volume of solution injected was of the order of  $10^{-6}$  cm<sup>3</sup> corresponding to about 0.5 per cent of the fibre volume. The exact volume injected by micropipette was calculated from the cross-sectional area of the shank of micropipette carrying the solution and by the distance an air bubble marker moved in the micropipette. When the solution was rapidly injected into the fibre, the fibre was injured. Therefore, the flow rate was controlled to be most suitable. In order to check the procedure of injection, the preliminary test was made with an injection of a strong dye solution into the fibre. The determination of the threshold value of the stimulation at the injected region was made with a pair of stimulating fluid electrodes under the following conditions: the interpolar length was 5 mm, and the interpolar region was electrically insulated in moistened air (Tamasige 1950). Thus, on injection of a test solution at the boundary between the fluid electrodes and the interpolar region, the threshold value of the injected region was represented in millivolts or microamperes.

*Ringer's fluid and test solution*: The Ringer's solution employed contained 120.0 mM NaCl, 2.0 mM KCl, 1.2 mM CaCl<sub>2</sub> and 2.0 mM Na-phosphate. Anaesthetics employed were chloroform, ether and urethan, dissolved in the Ringer's solution at various concentrations. For purpose of intracellular microinjection, it was desirable that the solutions are Ca-free, because Ca-ions combine with the sarcoplasm, and the Ca-coagulum of the sarcoplasm would occur (Heilbrunn 1940, Kamada and Kinoshita 1943). Anaesthetics for microinjection were dissolved in distilled water, isotonic (M/8) KCl or isotonic (M/8) K-phosphate solution. All the experimental solutions were buffered to pH=7.2 by the isotonic Na-bicarbonate.

## Results

### Effect of weak anaesthetics

On application of weak anaesthetics (0.05% urethan-Ringer, 0.6% ether-Ringer, 0.01, 0.04% chloroform-Ringer), a mechanical response elicited was at a lower stimulus strength than normal (Yamaguchi 1957). The resting and action membrane potential, however, were unaltered as compared with the normal. While the change in threshold was the most obvious, the production of repetitive and propagated action potentials during twitching could also be demonstrated in some fibres by lengthening of the duration of the stimulating pulse up to 1 msec. Especially, 0.04% chloroform-Ringer evoked such a repetitive response in most fibres even from a single shock of the duration of 0.1 msec and the typical record (B in Fig. 4) shows that the second action potential develops before completion of repolarization of the first action potential.

A possible explanation of these effects of weak anaesthetics will be discussed in a later section.

### Effect of anaesthetics at a medium concentration

With increase in the concentration of anaesthetics, the various transitory changes in excitability to the ultimate complete blockage of propagated response

of muscle fibres could be observed.

On application of anaesthetics of medium concentration (0.9, 2.2% urethan-Ringer, 0.6, 1.3% ether-Ringer, 0.05% chloroform-Ringer), the threshold of electrical stimulation becomes higher reversibly with the advance of time (Yamaguchi 1957). The most evident effect in the present study, was obtained by means of intracellular recording of action potential from the fibres treated with these anaesthetics (Fig. 2, Fig. 3 and Fig. 4). A typical action potential obtained with normal Ringer's

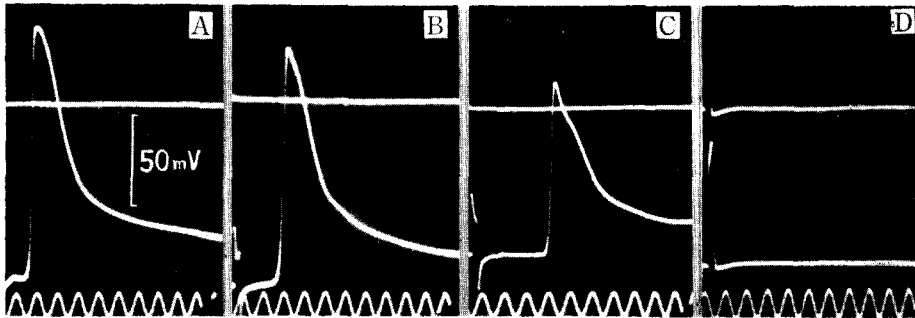

Fig. 2 Records from an experiment in which the fibre was treated with urethan at various concentrations : (A) normal Ringer's solution, (B) 0.9% urethan-Ringer, 10 minutes' treatment, (C) 2.2% urethan-Ringer, 10 minutes' treatment, (D) 4.5% urethan-Ringer, 3 minutes' treatment. The voltage amplification was kept constant. Time marks, 1000 c/sec.

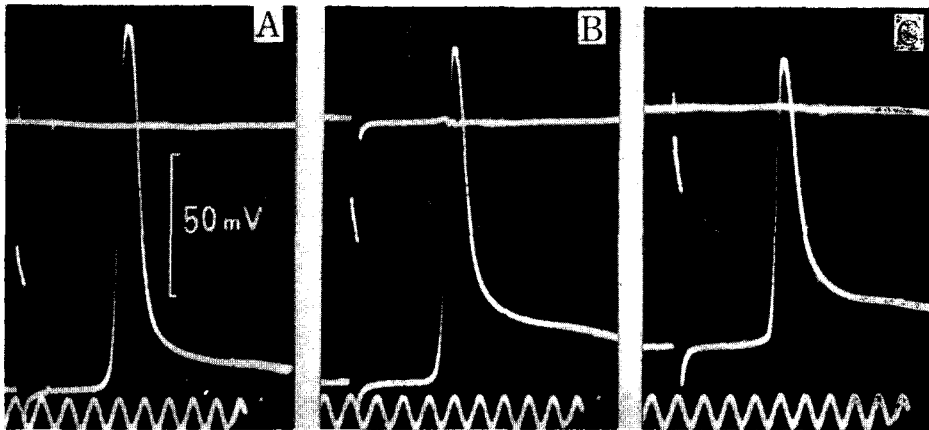

Fig. 3. Records from an experiment in which the fibre was treated with ether at various concentrations : (A) normal Ringer's solution, (B) 0.6% ether-Ringer, 5 minutes' treatment, (C) 1.3% ether-Ringer, 5 minutes' treatment. The voltage amplification was kept constant. Time marks, 1000 c/sec.

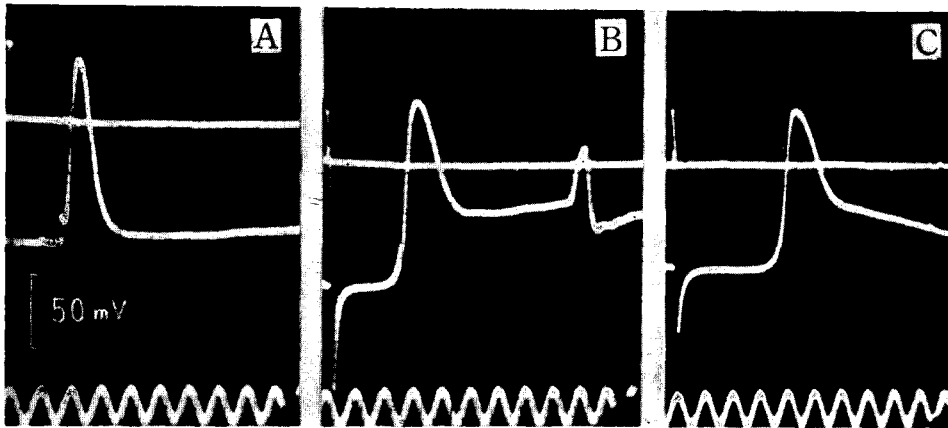

Fig. 4. Records from an experiment in which the fibre was treated with chloroform at various concentrations: (A) normal Ringer's solution, (B) 0.04% chloroform-Ringer, 10 minutes' treatment, (C) 0.05% chloroform-Ringer, 5 minutes' treatment. The voltage amplification was kept constant. Time marks, 1000 c/sec.

solution, is shown in the top record in each figure. The later records in each figure were obtained from the same fibre anaesthetized for 5–10 minutes, respectively. These figures show gradual decrease in the amplitude of action potential with increase in the concentration of anaesthetics. Associated with the change, there appeared a decrease in the rate of rise and fall of the action potential but an increase in the duration of action potential. The negative after-potential was enormously enhanced and greatly prolonged by anaesthetics and especially with chloroform, this change was remarkable. The conduction velocity of action potential was also reduced by anaesthetics. Moreover, Fig. 2 shows that urethan produces a remarkable notching in the falling phase of action potential.

If the concentration of anaesthetics was slightly increased (to 4.5% urethan-Ringer, to 3.2% ether-Ringer and to 0.6% chloroform-Ringer), the fibres were completely anaesthetized: they became non-responsive to electrical stimuli. In the experiment of Fig. 5, the Ringer's solution in the proximal fluid electrode ( $E_1$ ) was replaced with 4.5% urethan-Ringer. The amplitude of action potential was rapidly decreased and the fibre became inexcitable within 1 minute after replacement of the solution. But the propagation through the anaesthetized region was always restored on return to Ringer's solution. The records B and C in Fig. 6 were obtained intracellularly from the fibre treated with 3.2% ether-Ringer. The action potential quickly became smaller and the duration was prolonged. There was no overshoot of action potential (in B) and soon the action potential was completely abolished (in C). However, in the next record D, it is shown that on return to Ringer's solution from anaesthetic, the excitability went through a transient supernormality before complete recovery: there was a period in which

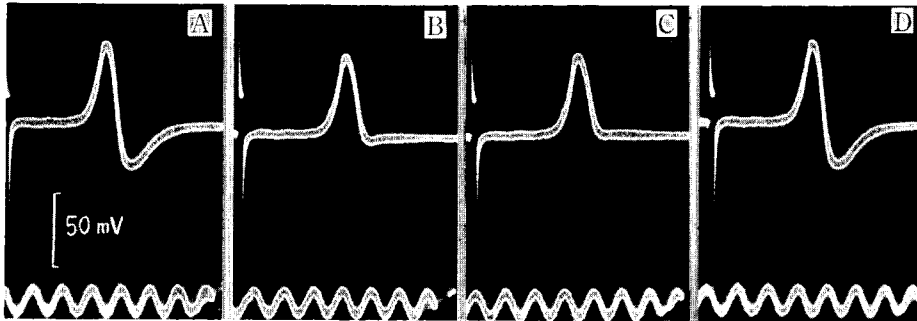

Fig. 5. Extracellular records show establishment of a conduction block of the action potential with 4.5% urethan-Ringer and the recovery on rescue : (A) normal Ringer's solution, (B) and (C) 4.5% urethan-Ringer, 1 and 2 minutes' treatment, respectively, (D) 3 minutes after return to the normal Ringer's solution. The voltage amplification was kept constant. Time marks, 1000 c/sec.

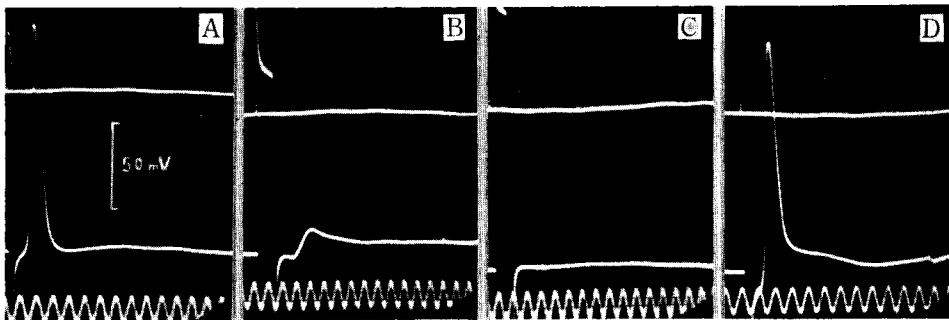

Fig. 6. Intracellular records show establishment of a conduction block of the action potential with 3.2% ether-Ringer and the recovery on rescue : (A) normal Ringer's solution, (B) and (C) 3.2% ether-Ringer, 1 and 3 minutes' treatment respectively, (D) 1 minute after return to the normal Ringer's solution. The voltage amplification was kept constant. Time marks, 1000 c/sec.

a larger action potential developed than normal. During this period, the threshold of the fibre was also decreased by more than 10% of the normal value, as reported by Yamaguchi (1957). But, whenever the fibre was exposed to 0.6% chloroform-Ringer for longer than 3 minutes, the propagation was blocked and the fibre became inexcitable irreversibly, followed by the contracture.

In Figures 7, 8 and 9, the time course of changes in the resting and the action membrane potential after application of 0.9% urethan-Ringer, 0.6% ether-Ringer and 0.05% chloroform-Ringer are traced, analyzing the changes in a amounts of the reversed potential beyond the zero level, the maximum rates of rise and fall of action potential and the height of the negative after-potential. All

these parameters show a rapid change in the measured values within the first few minutes, followed by a slow linear decline. In addition, the reversed potential, the rates of rise and fall, and the negative after-potential are more affected than the resting membrane potential. These values were varied up or down to 15–80% of the normal value within 5 minutes, whereas the resting membrane potential was reduced by only 5–10% of its normal value. It is also evident from Table I that all of the anaesthetic actions on membrane excitability of the fibre were not accompanied by any marked changes in the resting membrane potential.

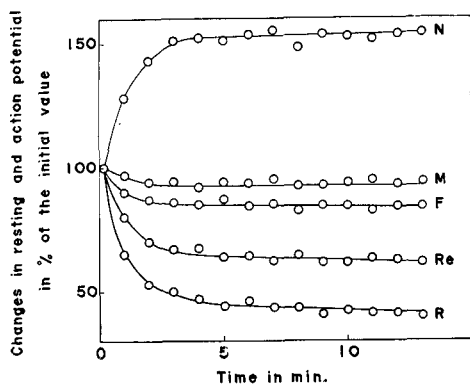

Fig. 7.

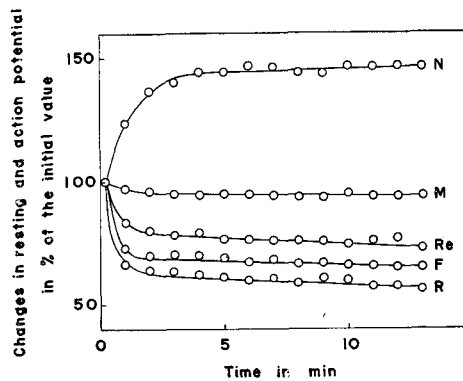

Fig. 8.

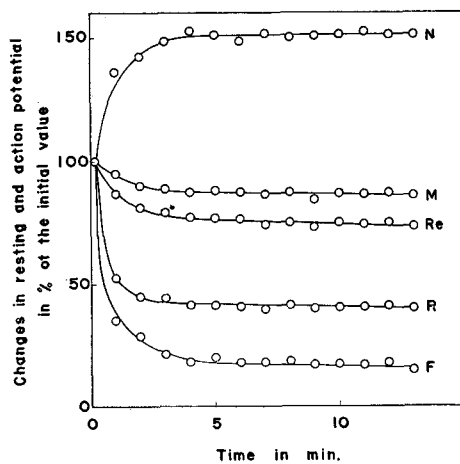

Fig. 9.

Figs. 7–9. (From left to right). Effects of 0.9% urethan-Ringer (Fig. 7), 0.6% ether-Ringer (Fig. 8), and 0.05% chloroform-Ringer (Fig. 9) upon values of the resting membrane potential (M), reversed potential (Re) beyond zero level potential maximum rates of rise (R) and fall (F) of the action potential, and heights of negative after-potential (N) in terms of per cent of initial values in the normal Ringer's solution.

### Effect of strong anaesthetics

If anaesthetics are applied in strong concentrations (saturated chloroform- and ether-Ringer and over 9% urethan-Ringer), they produce a contracture of the

Table 1 Effects of anaesthetics on the resting and action potential.

Anaesthetics concentration in Ringer's solution %	Resting potential mV	Action potential mV	Reversed potential mV	Negative after potential mV	Max. rate of rise V/sec	Max. rate of fall. V/sec
0% (control)	89.0(0.5)*	138.1(1.5)	47.0(1.0)	12.3(1.5)	543(15.0)	127(7.0)
0.45% Urethan	88.5(1.7)	127.0(1.0)	45.8(2.1)	23.8(3.1)	480(27.0)	101(3.3)
0.9 % Urethan	88.1(2.3)	125.8(2.7)	43.3(1.6)	34.0(4.1)	473(35.0)	85(2.1)
2.2 % Urethan	84.6(2.1)	104.5(4.1)	21.9(1.1)	32.7(2.0)	309(32.1)	36(8.0)
4.5 % Urethan	80.2(3.3)	0	0	0	0	0
0.3 % Ether	87.3(4.0)	123.5(1.2)	33.8(0.5)	15.2(1.1)	334(17.0)	125(4.8)
0.6 % Ether	89.9( 2.0)	110.0(1.2)	20.1(1.2)	23.0(2.3)	279(20.0)	124(3.6)
1.3 % Ether	85.9(1.8)	96.3(3.3)	11.9(5.3)	24.9(2.5)	260(12.0)	75(1.7)
3.2 % Ether	80.1(3.1)	0	0	0	0	0
0.04% Chloroform	88.1(1.0)	119.2(1.1)	30.0(1.2)	—	282(18.0)	73(5.1)
0.05% Chloroform	85.4(1.5)	113.1(4.1)	29.4( 4.1)	38.9(1.5)	220(30.0)	35(2.2)
0.08% Chloroform	75.2(2.9)	0	0	0	0	0

\* Figures in the parentheses are the significant errors involved in the measured figures.

fibre and then, irreversibly reduce the resting membrane potential by more than 70% of the normal value (Yamaguchi 1957).

On local application of these anaesthetics, conduction beyond the anaesthetized region was abruptly blocked. Only rarely did the anaesthesia of the fibre bring about reversible blockage of conduction, even when the anaesthetic applied was removed as quickly as possible. Therefore, the conduction blockage was generally irreversible and a disintegration of the muscle sarcoplasm seems to have occurred quickly.

On the other hand, when muscle fibres fully depolarized, by preliminary treatment with 125 mM KCl solution, were exposed to strong chloroform-Ringer solutions, it was observed that they shortened completely within about 2 minutes, producing a contracture. Accordingly, it may be said that strong anaesthetics do not only activate the normal membrane function which leads to contraction of the muscle fibre, but also they act directly on the contractile mechanism without the participation of the cell membrane.

#### Effect of divalent cations on the effects of anaesthetics

The effects of anaesthetics were altered in two ways by treatment with divalent cations (Ca-, Mg- and Ba-ions) according to whether the action was accelerated or inhibited.

A comparison of the effects of anaesthetics among 0.9% urethan-Ringer, 0.9% urethan-Ringer plus 24 mM CaCl<sub>2</sub>-Ringer, 0.9% urethan-Ringer plus 12 mM MgCl<sub>2</sub>-Ringer and 0.9% urethan-Ringer plus 12 mM BaCl<sub>2</sub>, on the action potential is shown in Fig. 10. In this figure, it is to be noted that Ca-ions can neutralize the

depressing effect of anaesthetic upon the action potential, whereas it is most striking that Mg- and Ba-ions can accelerate the anaesthetic effect by reducing the amplitude and the rate of rise and fall of action potential and its duration. In this case, the threshold for production of action potential is increased by 2-3 times in the presence of Mg- and Ba-ions, as compared with that in the absence of those cations but it is lowered slightly in the presence of Ca-ions.

Complete blockage of the excitation was rapidly obtained by 0.9% urethan-Ringer containing Mg- or Ba-ions of larger amount than 24 mM, or 2.2% urethan-Ringer containing 12 mM Mg- or Ba-ions. Moreover, if the concentration of Ca-ions with 0.9% urethan-Ringer was higher than 36 mM, the anaesthetic effect was somewhat increased and finally there appeared a complete blockage of the excitation.

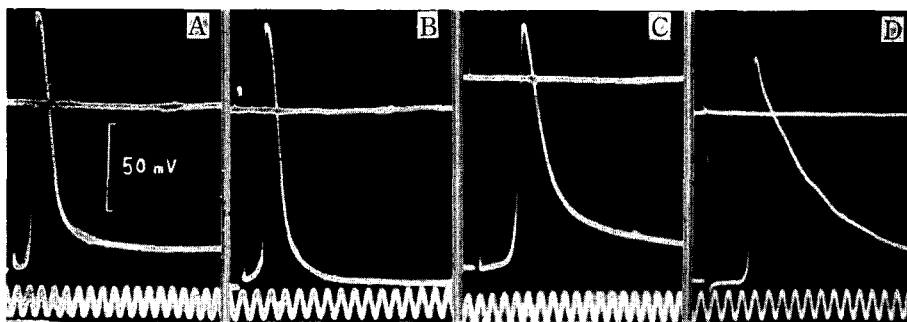

Fig. 10. Influences of divalent cations on the effect of anaesthetic: (A) 0.9% urethan-Ringer, (B) 24 mM  $\text{CaCl}_2$  + 0.9% urethan-Ringer, (C) 12 mM  $\text{MgCl}_2$  + 0.9% urethan-Ringer, (D) 12 mM  $\text{BaCl}_2$  + 0.9% urethan-Ringer. The voltage amplification was kept constant. Time marks, 1000c/sec.

### Microinjection experiment

Microinjection of a certain amount of distilled water or potassium chloride solution inside the muscle fibre brought about a local contraction, associated with a localized movement of the fibre toward the tip of micropipette, but that of potassium phosphate solution did not. This is in agreement with the results reported by Kamada and Kinoshita (1943), who suggested that the protoplasmic response to a stimulus depends upon the diminution in concentration of intracellular free phosphate ions.

If the solution in which anaesthetic were dissolved in the isotonic (125 mM) potassium phosphate solution at strong concentrations (saturated chloroform and ether, and over 9% urethan) was injected into the fibre, there appeared a local contraction at the injected site. It was then, observed that anaesthetics at low concentration diffused rapidly in a longitudinal direction along the fibre, whereas this did not occur with strong concentrations, but rather formed a protoplasmic clotting around the injection site. Hence, it is probable that strong anaesthetics

have a direct action on muscle sarcoplasm which results in precipitation of the sarcoplasm or combination with it, forming a barrier against further diffusion of the anaesthetic injected.

If the anaesthetic was injected successfully, the threshold of the fibre at the injection site, for response to electrical stimulus, was lowered, but that in the normal region was not. This change increased with increase in concentration of anaesthetics or the amount injected. For example, when  $1.3 \times 10^{-6}$  ml of 0.05% chloroform in 125 mM potassium phosphate solution or  $1.2 \times 10^{-6}$  of 0.9% urethan in 125 mM potassium phosphate solution was injected, the threshold at the injection site was lowered by more than 14.7% or 6.5% of the normal value, respectively. It was, however, difficult to determine the exact time course of this change, as the threshold was lowered rapidly. If the amount injected was smaller or the concentration of anaesthetics was lower, this change was more uncertain and soon disappeared completely.

The effects of injected anaesthetics on the resting membrane potentials at the injected site were not investigated in great detail, but a limited number of measurements were made in order to know whether intracellularly introduced anaesthetic is as powerful a depressant as an extracellularly applied one. While injection of 2.2% urethan dissolved in 125 mM potassium phosphate solution,  $3.0 \times 10^{-6}$  ml in volume, caused a slight reduction in the resting membrane potential (by 8.1 mV), injection of 125 mM potassium phosphate solution only,  $2.5 \times 10^{-6}$  ml in volume, had little effect on the resting membrane potential. The resultant reduction in threshold at the injection site, therefore, seems to occur in parallel with the change in the resting membrane potential.

### Discussion

Anesthetics at a low concentration produce an increase in the excitability of the frog muscle fibre. The effect is quite opposite to that produced by those at a high concentration (Yamaguchi 1957). On the other hand, it has been found by Daugherty (1937) in her studies on amoeba that dilute solutions of fat-soluble anaesthetics tend to increase the viscosity of the protoplasm in the cell interior, whereas the higher concentrations have exactly the opposite effect. It is, therefore, suggested that dilute solutions of anaesthetics generally act like sort of stimulating agents. In the present study, on application of weak anaesthetics, the production of repetitive action potentials during contractions could often be demonstrated by stimuli of prolonged duration, even through the resting membrane potential and action potential were generally unaltered. In the previous paper (1957) it was indicated that weak anaesthetics are entirely ineffective on the membrane and sarcoplasm resistances. From these facts, it seems that the stimulating effect of anaesthetics is dependent upon other factors than the direct change in ionic permeability of the cell membrane. In 1951 Berwick presented evidence to

show by chemical tests of cell homogenates that ether and chloroform caused a release of calcium ions from frog muscle fibres. In addition, Umezawa (1956) and Yamaguchi (1957) reported that anaesthetics exerted an inhibitory effect on the clot-formation on naked surface of muscle protoplasm. Thus, when the muscle fibre is treated with anaesthetics, there may occur a reduction in the concentration of calcium ions in the cell membrane or on the surface of it. On the other hand, the threshold for stimulation is lowered by reduction of the concentration of calcium in the fluid surrounding the muscle fibre and the muscle membrane seems to become very unstable, followed by two or more successive action potentials (Bülbring, Holman and Lüllmann 1956; Ishiko and Sato 1957). A possible explanation of the stimulating effect of weak anaesthetics is given as follows: the increase in the excitability of the muscle fibre by application of weak anaesthetics is caused by a secondary effect, i.e. the reduction in the concentration of calcium ions rather than by a direct effect.

The rising and falling phases of the action potential are related to the increases in sodium and potassium permeability (Hodgkin 1951 and many others). The records in Fig. 2-9 clearly show that with increases in the concentration, anaesthetics reduce the potential amplitude, especially at higher concentrations, and more markedly reduce the maximum rates of rise and fall of action potential, but increase the height of the negative after-potential, and finally abolish the action potential completely, whereas the resting membrane potential is only slightly reduced. This is in agreement with the results reported by Theselff (1956) and Weidmann (1955). On the other hand, Shanes *et al.* (1958) reported that in the squid giant axon the changes in potential spike configuration and in the inward and outward currents of voltage clamped axons agree in indicating that the increases in permeability to sodium and potassium ions during activity are depressed by cocaine and procaine. Therefore, the results that both of the changes in action potential and blockage of the excitation were brought about without marked change in the resting membrane potential and the fact that the resting membrane resistance was less affected than the action potential (Theselff 1956, Yamaguchi 1957), lead to the following suggestion. The depression of excitation by anaesthetics at medium concentration seems to be due mainly to the depression of the increase in permeability of the active membrane of the fibre.

It is, moreover, clearly indicated that divalent cations (Ca-, Mg- and Ba-ions) influence the anaesthetic effect under the condition in which anaesthetic is effective. That is to say, the anaesthetic effect was inhibited with higher concentration of calcium (24 mM), or was accelerated in the presence of magnesium or barium (over 12 mM). In 1922, Burridge reported that if beating frog hearts were perfused with cocaine so that the beating ceased, they could be revived by perfusion with calcium. He also found that perfusion with a solution of cocaine and calcium inhibited the effect of cocaine. It is, therefore, suggested that excess calcium may replenish the deficit of calcium ions in the cell membrane or

its neighbourhood caused by anaesthetics. In addition, the action of calcium which is a reversible increaser of the membrane resistance (Tamasige 1951) may neutralize directly the effect of an anaesthetic which increases the membrane permeability. Contrary to this, excess magnesium decreases the excitability of the muscle fibre (Ashkenaz 1938, Maaske and Gibson 1939). Recently Hisada (1958) also reported that the recovery phase of the action potential was prolonged in the presence of increased magnesium. Barium ions produced a marked decrease in the rising and falling phases of action potential and also in the resting membrane potential. Kleinfeld, Stein and Meyers (1952) showed that barium ions prolong the duration of the plateau of action potential of frog ventricular fibres. Thus, the most reasonable explanation of the accelerating effect seems to be that the increase in the permeability of the active membrane to Na- and K-ions is depressed twice in the presence of magnesium or barium ions.

On the other hand, strong anaesthetics seems to act on the cell membrane as abnormal increaser or ionic permeability. The finding that strong anaesthetic produced a contracture of the depolarized muscle fibre by preliminary treatment with potassium chloride, suggests that the action of strong anaesthetics is not confined to the cell membrane, but extends directly to the muscle protoplasm. This suggestion is further supported by the microinjection experiments in the author's previous paper (1958) and also by the above results namely : that injected strong anaesthetics produce, irreversibly, local contraction, contracture and the clotting of protoplasm.

When anaesthetics were successfully injected into the fibre, the threshold for the electrical stimulation at the injected site was lowered and the resting membrane potential was slightly reduced. This change seems to be due to the depolarizing action of anaesthetics in the cell interior. This depolarizing action of anaesthetics seems possibly to be explained by the diminution of free phosphate ions (Kamada and Kinosita 1943) or the increase of hydrogen ion concentration (Umezawa 1958) in the cell interior during activity. This theory is supported by the finding that when anaesthetics dissolved in potassium phosphate were injected into the fibres, they brought about an increase in the excitability of the fibre. Moreover, an electrotonic outward current which flows through the injected site (at the depolarizing site) may reduce the threshold of electrical stimulation. If this suggestion is valid, it becomes considerably easier to understand the peculiar phenomenon of the contracture produced by strong anaesthetics.

### Summary

1. Effects of anaesthetics, such as chloroform, ether and urethan at various concentrations on electrical properties of the frog single muscle fibres were investigated.
2. Weak anaesthetics (0.05% urethan-Ringer ; 0.06% ether-Ringer ; 0.01%, 0.04% chloroform-Ringer) increase the excitability of the fibre : in most cases, the

fibre responds to electrical stimuli of prolonged duration by exhibiting two or more successive action potentials. But no effect of these anaesthetics is observed on the shape of the action potential and the value of the resting membrane potential.

3. Anaesthetics at medium concentrations (0.9%, 2.2% urethan-Ringer; 0.6%, 1.3% ether-Ringer; 0.05% chloroform-Ringer) reduce slightly the resting membrane potential, whereas they markedly reduce the amplitude and the rates of the rise and fall of action potential while they increase the height of negative after-potential.

4. If the concentration of the anaesthetics is slightly increased (to 4.5% urethan-Ringer, to 3.2% ether-Ringer and to 0.6% chloroform-Ringer), the propagation of the action potential is blocked without marked change in the resting membrane potential. But the propagation can always be restored on return to Ringer's solution after a short transient period of supernormality.

5. The effect of one anaesthetic at medium concentration (0.9% urethan-Ringer) is enhanced by magnesium or barium ions in greater amount than 12 mM, whereas it is inhibited by 24 mM calcium ions.

6. When anaesthetics are applied at strong concentration (over 9% urethan-Ringer, saturated ether- and chloroform-Ringer), the membrane potential falls abruptly by more than 70% of the normal value and produces a strong contracture of the fibre. Moreover, a strong concentration of chloroform produces also a contracture of the fully depolarized fibre by preliminary treatment with the isotonic potassium chloride solution.

7. When anaesthetics are successfully injected into the fibre, the threshold for response to electrical stimulation at the injected site is lowered. This change seems to occur in parallel with the slight depolarization of the resting membrane potential at the injected site.

8. A possible explanation of the anaesthetizing mechanism is also given.

The author wishes to express his appreciation to Professor Mituo Tamagishi for his kind guidance and encouragement throughout the course of these experiments and for improvement of the manuscript.

### References

- Ashkenaz, E.W. 1938. Magnesium narcosis in muscle. *J. Cell. & Comp. Physiol.* 11 : 163-174.
- Berwick, M.C. 1951. The effect of anaesthetics of calcium release. *J. Cell. & Comp. Physiol.* 38 : 95-107.
- Bülbring, E., M. E. Holman & H. Lüllmann 1956. Effects of calcium deficiency on striated muscle of the frog. *J. Physiol.* 133 : 101-117.
- Burridge, W. 1922. Experiments with cocaine. *Arch. int. de pharmacodyn. et de thérap.*

- 26 : 115. Cited by Berwick, M.C. (1951)
- Daugherty, K. 1937. The action of anaesthetics on amoeba protoplasm. *Physiol. Zool.* 10 : 473-483.
- Heilbrunn, L.V. 1940. The action of calcium on muscle protoplasm. *Physiol. Zool.* 13 : 88-94.
- Hisada, M. 1958. Effect of stretch on neuromuscular transmission in a nerve-supplied single muscle fibre. *J. Fac. Sci. Hokkaido Univ. Ser. VI*, 14 : 74-82.
- Hodgkin, A.L. 1951. The ionic basis of electric activity in nerve and muscle. *Biol. Rev.* 26 : 339-409.
- Ishiko, N. & M. Sato 1957. The effect of calcium ions on electrical properties of striated muscle fibres. *Jap. J. Physiol.* 7 : 51-63.
- Kamda, T. & H. Kinoshita 1943. Disturbances initiated from naked surface of muscle protoplasm. *Jap. J. Zool.* 10 : 469-493.
- Kleinfeld, M., E. Stein & S. Meyers 1954. Effects of barium chloride on resting and action potentials of ventricular fibres of the frog. *Circulation Res.* 2 : 488-493.
- Lillie, R.S. 1923. "Protoplasmic action and nervous action." Chicago : Univ. of Chicago Press.
- Maaske, C.A. & B. Gibson 1939. The effects of magnesium upon denervated mammalian muscle. *Amer. J. Physiol.* 127 : 486-493.
- Overton, E. 1901. "Studien über die Narkose." Jena : Fischer.
- Shanes, A.M., Freygang, W.H.Jr. Grundfest, H. & E. Amatriek 1959. Anaesthetic and calcium action in voltage-clamped squid giant axon. *J. Gen. Physiol.* 42 : 793-802.
- Tamasige, M. 1950. Membrane and sarcoplasm resistance in an isolated frog muscle fibre. *Annot. Zool. Jap.* 23 : 125-134.
- . 1951. Effect of potassium ions upon the electrical resistance of an isolated frog muscle fibre. *Annot. Zool. Jap.* 24 : 141-149.
- Thesleff, S. 1956. The effect of anaesthetic agents on skeletal muscle membrane. *Acta Physiol. Scand.* 37 : 335-349.
- Umezawa, S. 1956. Electrical stimulation of single muscle fibre with the electrodes placed out- or inside of cell membrane. *Zool. Mag.* 65 : 427-434 (in Japanese).
- . 1958. Role of intracellular phosphate ions on contraction and coagulum formation of an isolated frog muscle fibre. *Annot. Zool. Jap.* 31 : 127-135.
- Weidmann, S. 1955. Effects of calcium ions and local anaesthetics on electrical properties of purkinje fibres. *J. Physiol.* 129 : 568-582.
- Yamaguchi, T. 1957. Effect of anaesthetics on isolated frog muscle fibres. *Annot. Zool. Jap.* 30 : 99-105.
- . 1958. Microinjection into animal single cells. *Symposia Cell. Chem.* 8 : 93-99 (in Japanese with English summary).
-