



# HOKKAIDO UNIVERSITY

Title	Reproductive System and Oogenesis in the Freshwater Oligochaete, Tubifex hattai (With 3 Text-figures and 3 Plates)
Author(s)	HIRAO, Yuki-hisa
Citation	北海道大學理學部紀要, 15(3), 439-448
Issue Date	1964-12
Doc URL	<a href="https://hdl.handle.net/2115/27390">https://hdl.handle.net/2115/27390</a>
Type	departmental bulletin paper
File Information	15(3)_P439-448.pdf



# Reproductive System and Oogenesis in the Freshwater Oligochaete, *Tubifex hattai*<sup>1)</sup>

By

Yuki-hisa Hirao

Zoological Institute, Hokkaido University  
(With 3 Text-figures and 3 Plates)

Recently, Inase ('60a, b) studied the effect of culture solutions on the embryonic development of *Tubifex hattai* and suggested the possible role of the cocoon in its normal development. Lehmann ('40, '56) demonstrated the importance of the egg cortex and polarity in the early development of *Tubifex rivulorum*. Despite these interesting reports, the propagation and development of freshwater oligochaetes are not yet thoroughly understood, primarily because of the difficulties involved in artificial insemination of these worms.

The purpose of the present study is to examine the exact structure of the reproductive system and oogenesis of the freshwater oligochaete, *Tubifex hattai*.

## Material and Method

The material used in this study was the freshwater oligochaete, *Tubifex hattai*, collected from the stream which runs through the campus of Hokkaido University. This worm forms clumps on the soft muddy bottom of the stream. Several different oligochaetes, such as *Limnodrilus* and *Rhynchelmis*, are often found in the same clumps, but separation of *Tubifex hattai* can be easily accomplished by mechanically stimulating the clump of worms. A great many of mature worms and cocoons are found all the year round, indicating that the sexual season of this species is unlimited. The collected worms were placed in vats with a small amount of sterilized sand on the bottom in constantly running water at 10–15°C, and occasionally nourished with yeasts according to Lehmann's method ('41).

For morphological studies of the reproductive system, the worms were fixed in Bouin's fluid. As the occasion demanded, Gilson's fluid and 10% formalin were also employed. Before fixation, the worms were kept in water without sand for a few hours, and allowed to discharge ingested food. In either fixatives or 70% alcohol, the parts anterior and posterior to the clitellum were cut off and 5–7 $\mu$  sections of the clitellar portion were made by the ordinary paraffin method. They were stained with Delafield's hematoxylin and eosin, Heidenhain's iron hematoxylin or Heidenhain's azan stain. When necessary, Feulgen's reaction for DNA and the alcian blue-PAS test for polysaccharides were also employed.

---

1) Contribution No. 665 from the Zoological Institute, Faculty of Science, Hokkaido University, Sapporo, Japan.

*Jour. Fac. Sci. Hokkaido Univ. Ser. VI, Zool. 15, 1964.*

### Observations

*General features of reproductive system:* Fully matured worm, about 10 cm long and 1 mm wide, is composed of 90–110 segments. On the dorsal and ventral sides of each segment, there are two pairs of setae. The clitellum occupies segments 10 to 11, in which both male and female reproductive organs are located. As the oviposition draws near, the clitellum becomes swollen and opaque. It is possible to detect the presence of mature eggs in the clitellum through the dorsal body wall (Fig. 4). On the ventral surface of the clitellum, there are pairs of both male and female genital pores, and of openings of spermathecae. From external observation, however, only a pair of male pores are recognizable (Fig. 5).

The arrangement and relation of the reproductive organs in the clitellum are shown in Figs. 1, 2 and 3. As previously mentioned, there are a pair of spermathecae (st), the organs for receiving and storing the spermatozoa, in segment 10. Each spermatheca consists of two parts, a pear-shaped globule and a cylindrical duct which opens on the ventro-lateral side of the segment. A pair of testes (t) are attached to the posterior surface of septum 10, and are found in the ventral portion of the segment. There are two cylindrical sperm sacs (ss), one anterior and one posterior.

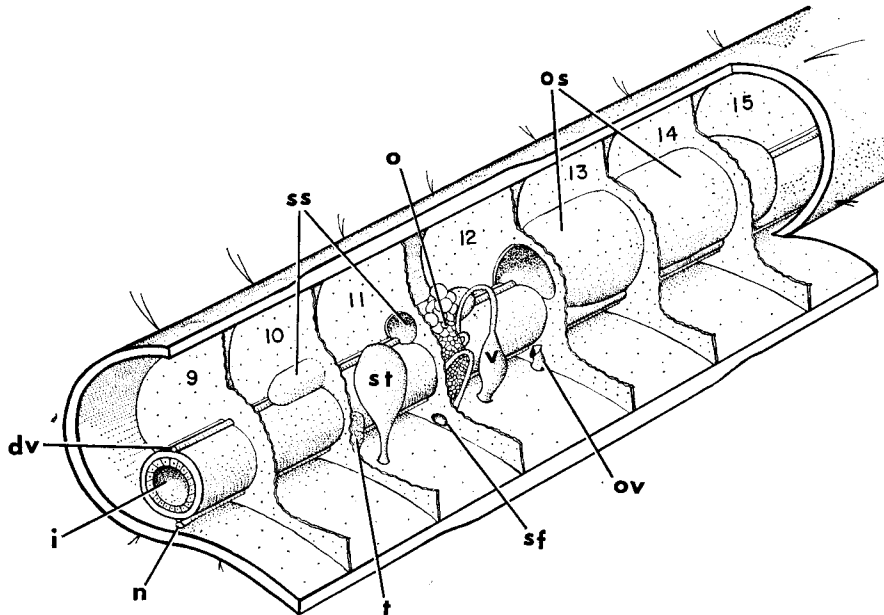

Fig. 1. Stereogram showing the arrangement of the reproductive organs in the clitellar part of *Tubifex hattai*: dv, dorsal blood vessel; i, intestine; n, ventral nerve cord; o, ovary; os, ovisac; ov, oviduct; sf, sperm funnel; st, spermatheca; ss, spermsac; t, testis; v, vas deferens.

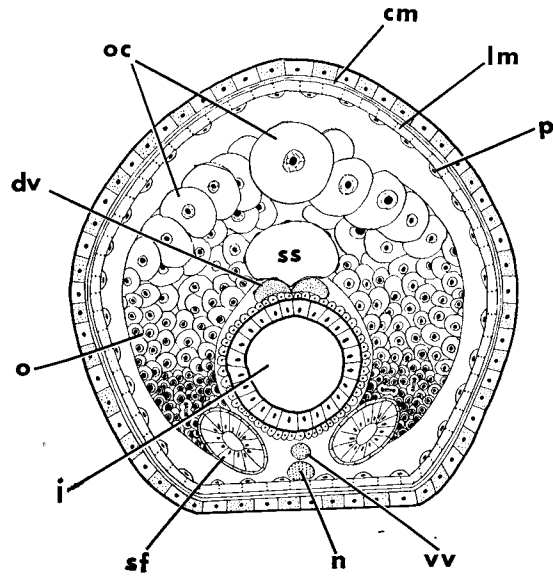

Fig. 2

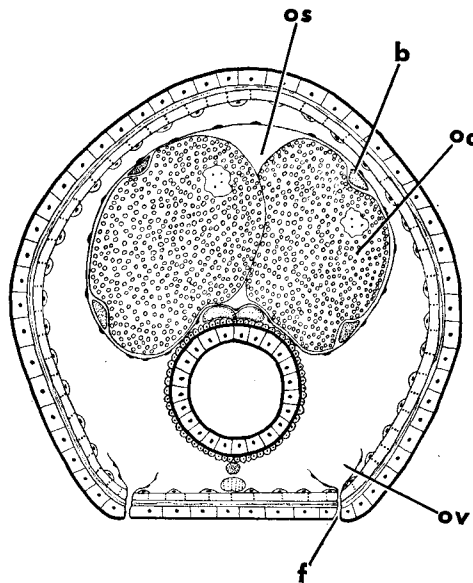

Fig. 3

Figs. 2-3. Illustration of cross section at the level of septum 11 (figure 2) and septum 12 (figure 3). b, blood vessel; cm, circular muscle; dv, dorsal blood vessel; f, female pore; i, intestine; lm, longitudinal muscle; n, ventral nerve cord; o, ovary; oc, oocyte; os, ovisac; ov, oviduct; p, peritoneal cell; sf, sperm funnel; ss, spermsac; vv, ventral blood vessel.

The lumina of these sacs open directly into the coelom of this segment. A pair of sperm funnels (sf), located on the antero-ventral surface of septum 11, also open into the coelom of this segment. A pair of long, coiled vasa deferentia (v) connect with the male atria and terminate in the opening in the ventral body wall of segment 11, male pores.

The paired ovaries (o) are fan-shaped sacs attached to the posterior ventral surface of septum 11, spreading toward the dorsal side of the coelom along the wall of intestine. Each ovary is filled with a great many of young egg cells, and enclosed by an exceedingly thin ovarian wall. Towards the ventral and lateral sides, some part of the ovarian wall is attached to the coiled vas deferens which, as previously described, lies in this segment. In the coelom of this segment, there are a number of large oocytes which have been liberated from the ovary. The median ovisac (os) is fairly large, extending from segment 12 to 14. The ovisac opens directly into the coelom of segment 11. A pair of short ducts, oviducts (ov), lie along the anterior surface of septum 12. The funnels of these ducts open into the coelom of segment 11, and the opposite ends terminate in the openings on the ventral surface of segment 11, female pores (Fig. 6).

*Oogenesis*: It is generally recognized that the youngest germ cells occupy the most ventral part of the ovary, and that these oocytes grow gradually towards the dorsal side of the ovary. In the present observations, the egg cells in the ovary are divided into 3 groups according to their size and morphological characteristics.

The youngest germ cells, about  $5-7\mu$  in diameter, occupy the most ventral portion of the ovary. The cytoplasm of these cells is only faintly stained with any of the dyes used. The nucleus is filled with chromatins and contains a nucleolus of about  $3\mu$  in diameter. There are a number of mitotic figures in the area occupied by these cells, indicating that mitotic division occurs very frequently (Fig. 7) and that these cells are probably oogonia of the multiplication period.

The smallest oocytes, about  $15-20\mu$  in diameter, are in the median portion of the ovary (Fig. 10). These oocytes are characterized by the strong affinity of their cytoplasm for hematoxylin. The cytoplasm of these cells seems to be rather thin. The nucleus contains a large basophilic nucleolus surrounded by chromatins (Fig. 8). It should be noted that one or two huge bodies are present among the oocytes (Fig. 10, h). Repeated examinations of the sections of a number of worms reveal that these huge bodies are always found in the ovaries of mature worms, fixed either immediately after collection or after about 30 days' captivity in the laboratory. Furthermore, they are usually found in worms during the period of active oviposition, but never in the worms resting from oviposition. Therefore these bodies seem to have some relation to the occurrence of oviposition. Careful observations of ovaries undergoing repeated oviposition reveal that about 8-10 oocytes aggregate and fuse together, losing their cell boundaries. Like the surrounding oocytes, each nucleus contains a nucleolus and tiny chromatins. When Feulgen's

nuclear reaction is applied, however, these nuclei react more intensely than do those of the surrounding oocytes (Fig. 11). Afterward these nuclei fuse together in the center of the cytoplasm, forming a single large, irregular mass (Fig. 12). This huge body with its voluminous cytoplasm and nucleus is so strange that it is difficult to imagine that it is of oocyte-origin. Later, the mass of nuclei undergoes gradual vacuolization. At the same time, only a small portion of the mass retains a positive Feulgen reaction, and even this small portion finally gives a negative reaction (Fig. 13). The huge body finally degenerates and disappears, since vacuolization proceeds not only in the nucleus, but also in the cytoplasm (Fig. 14).

The largest oocytes in the ovary occupy the most dorsal portion of the ovary and are about 40–150 $\mu$  in diameter (Fig. 9). Except for great increase in size, these oocytes do not show remarkable morphological changes. Their cytoplasm stains deeply with hematoxylin and their spherical nuclei contain a nucleolus and chromatin (Fig. 15). The size of the nucleolus does not increase appreciably, but the nucleus increases in size with the growth of the oocyte. It is observed that there is no boundary between the coelom and the ovarian oocytes located in the most dorsal portion of the ovary. There is no ovarian wall in this portion of the ovary, and the largest oocytes in the ovary are thus exposed directly to the coelom. Since this portion of the coelom is very narrow, the surfaces of the exposed ovarian oocytes come in contact with a layer of the peritoneal lining of the inner surface of body wall (Fig. 9). The peritoneal cells increase in number in this area and are detached from the wall and one or two these free peritoneal cells attach themselves to the surface of the exposed oocytes. At first these cells are oval-shape, 7 $\times$ 5 $\mu$ , but later they decrease in size. An extremely thin egg membrane is found around these oocytes, which is easily detected by a strong PAS reaction (Fig. 16). The cells of peritoneal origin attach themselves to the outer surface of this membrane.

The oocytes, 200–250 $\mu$  in diameter, leave the ovary and fill the coelom in segment 11 and the ovisac. Usually there are 7–8 oocytes, and yolk formation occurs. Yolk deposition proceeds at the same rate in all of the coelomic oocytes. It should be mentioned here that the dorsal blood vessel in segment 11 branches repeatedly until it results in many fine capillaries which enclose the oocytes in the coelom of segment 11 and the ovisac (Fig. 17). The surface of the oocyte becomes indented where the capillary vessels are supplied (Fig. 25). In the first stage of yolk deposition, a cell or cells of peritoneal origin still adhere to the oocytes. The affinity of the oocyte cytoplasm for hematoxylin increases in comparison with the preceding stages. The nucleus contains spirally coiled chromatin threads and a nucleolus. The latter now includes one or more highly refractive particles (Fig. 18). The yolk makes its first appearance as small granules in one area on the periphery of the oocyte cytoplasm (Fig. 20). The granules are identified by their strong affinity for Heidenhain's iron hematoxylin. The yolk granules gradually increase in number in the periphery of the oocyte cytoplasm in succeeding stages, and appear

on the opposite side of the periphery (Figs. 21-23).

In oocytes, 280-320 $\mu$  in diameter, approximately one half of the oocyte is filled with yolk granules. In this stage, the cells of peritoneal origin have disappeared from the surface of the oocyte. The germinal vesicle is located in that portion of the cytoplasm which is not filled with yolk granules, showing the animal-vegetal axis of the egg (Fig. 24). The nuclear membrane is slightly irregular, or "sacculated". The highly refractive particles in the nucleolus are still present. With azan stain, the nuclear sap surrounding the nucleolus appears as a clear zone, homogeneously stained with aniline blue (Fig. 18). It is noteworthy that, in succeeding stages, the nucleoli increase in number and there are more than 10 nucleoli in the germinal vesicle (Fig. 19). In addition, the entire nuclear sap stains with aniline blue. In these oocytes, all of the cytoplasm is filled with yolk granules except for narrow perinuclear and peripheral areas. There is no difference in the distribution and/or size of the granules in the animal and vegetal hemispheres (Fig. 24). The existence of animal and vegetal axis can only be detected by the eccentric localization of the germinal vesicle. Distribution of the capillary vessels on the surface of the oocytes is also unrelated to the polarity of the oocytes.

The largest oocytes, 350-400 $\mu$  in diameter, found in the coelom of segment 11 and in the ovisac, initiate maturation division. All of these oocytes, 7-8 in number, begin to form maturation spindles at nearly the same time. In the preceding stage, the germinal vesicle is located in the middle of the oocyte, between the center and the outer edge, and the nuclear membrane begins to dissolve in this area. Condensed chromatins are visible within the nucleus. With the dissolution of the nuclear membrane, a number of small nucleoli flow into the surrounding cytoplasm (Fig. 26), and soon disappear. Then the metaphase spindle of the first maturation division is formed, with large asters at the both ends (Fig. 27). The position of the first maturation spindle in the cytoplasm does not alter, at least as long as the oocyte is located in the coelom or the ovisac. The spindle lies somewhat below the surface, either parallel, perpendicular, or oblique to the surface. These oocytes are still supplied with capillary vessels. It is the oocytes in this stage which can be observed through the swollen body wall of the clitellum with the naked eye.

### General Consideration

This investigation disclosed that the ovary of a worm, which contains only oogonia and smallest oocytes, is completely enclosed by a thin ovarian wall. In the fully matured worm, however, the wall can not be detected in the most dorsal portion of the ovary, and the ovarian oocytes in this area are directly exposed to the coelom. This shows that the dorsal ovarian wall is ruptured by the growing oocytes. Later, the oocytes are released from the ovary and suspended in the coelom, and then enter the ovisac. Since all of the oocytes in the coelom or the ovisac, usually 7-8, are always in the same stage of yolk deposition and maturation,

it is probable that they are released simultaneously from the ovary. Examinations of worms undergoing repeated oviposition, which usually occurs at 7 day intervals, prove that yolk formation in the oocytes starts after they leave the ovary. Since there are no yolk laden oocytes in worms which have just completed oviposition, it may be assumed that yolk synthesis in the liberated oocyte begins and continues for one week.

It is generally known that growing invertebrate oocytes are either accompanied by nurse cells or surrounded by follicle cells. For example, it has been reported in the polychaete worm, *Ophryotrocha*, that some oocytes are transformed into nurse cells and that each functional oocyte is accompanied by a nurse cell which is directly connected to the cytoplasm of the oocyte and is absorbed by the growing oocyte as a nutritive (Korschelt, 1895). In the present study, one or two huge bodies containing large nuclei are observed among the smallest oocytes. They apparently originated from the oocytes and are vacuolized as ovarian maturation advanced. These bodies are always found in the ovaries of mature worms undergoing repeated oviposition, but never found in worms resting from oviposition. Apparently, there is some relation between the appearance of these huge bodies and the growth of the oocytes.

The largest ovarian oocytes are accompanied by one or two small cells which originate from the peritoneal lining of the body wall. These cells are so small that it can hardly be supposed that they correspond to the nurse cells. It seems noteworthy that these cells of peritoneal origin only appear when the egg membrane is formed, and it is reasonable to assume that they have some relation to the formation of the egg membrane. In this connection, it is interesting to note that a similar observation has recently been reported by Cowden ('61), who studied the oogenesis of *Chiton*. According to him, a layer of "accessory cells", surrounds each ovarian oocyte, and disappears after the egg membrane is completely formed. He suggests that these cells produce a tanning agent which hardens the egg membrane.

In the present investigation, deposition of yolk granules in the oocyte was observed to begin after the oocytes were released into the coelom. Similar observations of yolk deposition have been reported in some marine polychaetes by Okada ('41) and Simpson ('62). It is surprising that deposition of a relatively large quantity of yolk granules in cytoplasm is accomplished within so short a time, 5-7 days. In terrestrial earthworms, a possible role in yolk formation has been suggested for osmiophilic granules derived from Golgi bodies and mitochondria (Foot & Strobell '01, Gatenby & Nath '26, Nath '29). Oocytes undergoing yolk granule formation are thickly surrounded by branched capillary vessels. It is highly possible that these oocytes receive nutritives through these capillary vessels. In this connection it is interesting to note that, in higher vertebrates, there is a good deal of evidence for the theory that intact blood proteins can cross the barrier formed by follicle cells and enter the growing oocytes. For example, Schechtman's

recent serological study ('56) clearly demonstrated that, in chicken egg, the yolk proteins very closely resemble the maternal blood.

In the present observations, neither the presence of a particular cortical cytoplasm, nor a gradient distribution of the yolk granules could be detected, even in the largest oocytes. The polarity of the full grown oocytes was manifested only in the site of the meiotic spindle. However, it seems worthy of mention that yolk granules appearing in the coelomic oocytes are first deposited in one half of the cytoplasm.

### Summary

The reproductive system and oogenesis of a freshwater oligochaete, *Tubifex hattai*, was studied. The results may be summarized as follows:

1. A pair of ovaries are attached to the posterior ventral surface of septum 11. In worms resting from oviposition, the ovary is surrounded by a thin wall, but in worms undergoing repeated oviposition, part of this wall disappears.
2. The oogonia in the multiplication period occupy the most ventral portion of the ovary and they extend toward the dorsal side as they gradually increase in size. Usually, 7-8 oocytes are released from the dorsal portion of the ovary to the ovisac, where the oocytes undergo yolk deposition and maturation.
3. Huge bodies containing large nuclei are found among the youngest ovarian oocytes. These bodies are formed by fusion of several of the youngest oocytes and they undergo vacuolization as ovarian maturation advances. They are found in worms undergoing repeated oviposition, but never in those resting from oviposition.
4. The egg membrane appears for the first time around the oocytes in the most dorsal portion of the ovary. One or two small cells of peritoneal origin attach themselves to the surface of these oocytes, and disappear at the early stage of yolk formation.
5. In oocytes in the ovisac or suspended in the coelom of segment 11, deposition of yolk is initiated and completed within 5-7 days. The yolk appears as small granules in one half of the peripheral cytoplasm of the oocyte, the vegetal pole, and continues formation there. The first sign of polarity in the egg is detected in these oocytes.
6. Oocytes in the process of active deposition of yolk are entwined with a considerable number of fine capillary vessels. These vessels are branches of the dorsal blood vessels. These capillary vessels appear to be intimately associated with the supply of nutritives used in the formation of the yolk granules.
7. When the yolk granules have filled about half of the oocyte cytoplasm, the germinal vesicle moves towards the middle of the yolk free area, between the center and the animal pole of the oocytes. The metaphase spindle of first maturation division is formed in this position.

The author wishes to express his sincere appreciation to Professor Atsuhiko Ichikawa, under whose direction the present study was carried out. He is also grateful to Professor Yasuhiko Kanoh, Dr. Tadashi S. Yamamoto and Dr. Chiaki Katagiri for their invaluable suggestions and advice during the course of this work.

### References

- Cowden, R.R. 1961. A cytochemical investigation of oogenesis and development to the swimming larval stage in the chiton, *Chiton tuberculatum*. Biol. Bull., **120**: 313-325.
- Foot, K. & E.C. Strobell, 1901. Photographs of the egg of *Allobophora foetida* II. J. Morph., **17**: 517-552.
- Gatenby, J.B. & V. Nath, 1926. The oogenesis of certain invertebrate, with special reference to *Lumbricus*. Quart. J. Micr. Sci., **70**: 371-389.
- Harvey, L.A. 1931. The oogenesis of *Lumbricus*: A restatement. Quart. J. Micr. Sci., **74**: 235-256.
- Inase, M. 1960a. On the double embryo of the aquatic worm *Tubifex hattai*. Sci. Rep. Tôhoku Univ., Biol., **26**: 59-64.
- , 1960b. The culture solution of the eggs of *Tubifex*. Sci. Rep. Tôhoku Univ., Biol., **26**: 65-67.
- Korschelt, E. 1895. Ueber Kernteilung, Eireifung und Befruchtung bei *Ophryotrocha puerilis*. Z. Wiss. Zool., **60**: 541-688.
- Lehmann, F.E. 1940. Polarität und Reifungsteilungen bei zentrifugierten *Tubifex*-Eiern. Rev. Suisse. Zool., **47**: 177-182.
- , 1941. Die Zucht von *Tubifex* für Laboratoriumszwecke. Rev. Suisse. Zool., **48**: 559-561.
- , 1956. Plasmatische Eiorganisation und Entwicklungsleitung beim Keim vom *Tubifex*. Naturwiss., **43**: 281-296.
- Nath, V. 1926. Studies on the shape of the Golgi apparatus. II. Observations on the fresh egg of the Indian earthworm, *Pheretima posthuma*. Quart. J. Micr. Sci., **73**: 477-506.
- Nomura, E. 1926. On the aquatic Oligochaeta, *Tubifex hattai*. Sci. Rep. Tôhoku Imp. Univ., Biol., **1**: 191-228.
- Okada, K. 1941. The gametogenesis, the breeding habits and the early development of *Arenicola cristata*. Sci. Rep. Tôhoku Imp. Univ., Biol., **6**: 99-146.
- Penners, A. 1922. Die Furchung von *Tubifex rivulorum* Lam. Zool. Jahrb. Anat. Ontog., **43**: 323-362.
- , 1923. Die Entwicklung des Keimstreifs und die Organbildung bei *Tubifex rivulorum* Lam. Zool. Jahrb. Anat. Ontog., **45**: 251-308.
- Schechtman, A.M. 1956. Uptake and transfer of macromolecules by cells with special reference to growth and development. Intern. Rev. Cytol., **5**: 303-322.
- Simpson, M. 1962. Gametogenesis and early development of the polychaete, *Glycera dibranchiata*. Biol. Bull., **123**: 412-423.

## Explanation of Plates XV-XVII

### Plate XV

Fig. 4. Dorsal view of worm with full grown oocytes in clitellum and ovisac. Note remarkable swelling and opaqueness of clitellum (arrow). Anterior part uppermost. Anesthetized worm. ca.  $\times 10$ .

Fig. 5. Ventral view of clitellar portion showing male pores (arrow). Fixed worm. ca.  $\times 20$ .

Fig. 6. Cross section of clitellar portion showing female pores (arrow). o, oviduct. Azan-preparation. ca.  $\times 400$ .

Fig. 7. Section through the most ventral portion of ovary showing oogonia of multiplication period. Hematoxylin-preparation. ca.  $\times 630$ .

Fig. 8. Section through ovary showing oocytes in youngest stage. Hematoxylin-preparation. ca.  $\times 760$ .

Fig. 9. Largest ovarian oocytes in most dorsal portion of ovary. Note oocytes coming in contact with peritoneal cells (arrow). Hematoxylin-preparation. ca.  $\times 360$ .

Fig. 10. Section through clitellar portion showing structure of ovary. h, huge body. Hematoxylin-preparation. ca.  $\times 70$ .

### Plate XVI

Figs. 11-14. Section through ovary showing various huge bodies. ca.  $\times 520$ . Fig. 11. Aggregation of oocytes. Note loss of cell boundary in the aggregation. Fig. 12. Fusion of nuclei. Note vacuolization in the nuclear material. Figs. 13 & 14. Vacuolization in nucleus and cytoplasm.

Figs. 15 & 16. Section through largest oocyte in most dorsal portion of ovary. ca.  $\times 360$ . Fig. 15. Note chromatins, and cells of peritoneal origin (arrow) attached to oocyte. Hematoxylin-preparation. Fig. 16. First appearance of egg membrane. Alcian blue-PAS-preparation.

Fig. 17. Distribution of capillary vessels surrounding oocytes in the ovisac. Anterior to the right. Fixed worm. ca.  $\times 40$ .

Figs. 18 & 19. Higher magnification of germinal vesicle in stage of yolk formation. Azan-preparation. ca.  $\times 700$ . Fig. 18. Highly refractive particles in nucleolus and zone stained with aniline blue (arrow) around nucleolus. Fig. 19. Several nucleoli in germinal vesicle.

### Plate XVII

Figs. 20-22. Section through oocytes in the ovisac, showing appearance and deposition of yolk granules. Note eccentric deposition of granules. ca.  $\times 400$ .

Fig. 23. Oocytes in stage of yolk deposition. Germinal vesicle is on one side of cytoplasm. Heidenhain's iron hematoxylin-preparation. ca.  $\times 400$ .

Fig. 24. Full grown oocytes. Germinal vesicle in eccentric location. Heidenhain's iron hematoxylin-preparation. ca.  $\times 400$ .

Fig. 25. Peripheral portion of oocyte in ovisac. Note indentations of surface from contact with capillary vessels. Heidenhain's iron hematoxylin-preparation. ca.  $\times 400$ .

Fig. 26. Section through nucleus of oocyte in the ovisac, showing dissolution of nuclear membrane. Hematoxylin-preparation. ca.  $\times 400$ .

Fig. 27. Section through fully matured oocyte in ovisac, showing metaphase spindle of first maturation division. Hematoxylin-preparation. ca.  $\times 400$ .

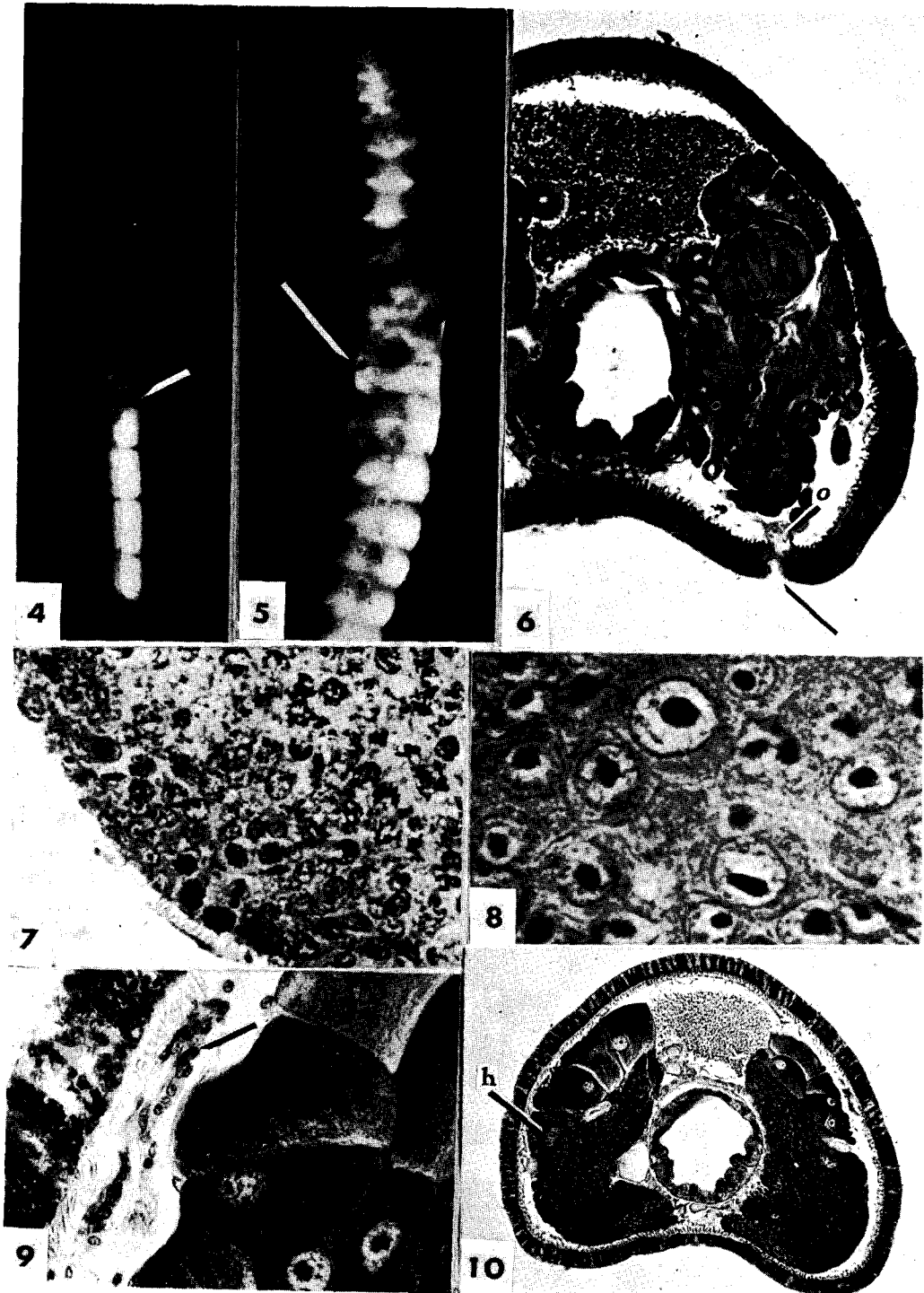

*Y. Hirao: Reproductive System and Oogenesis of Tubifex*

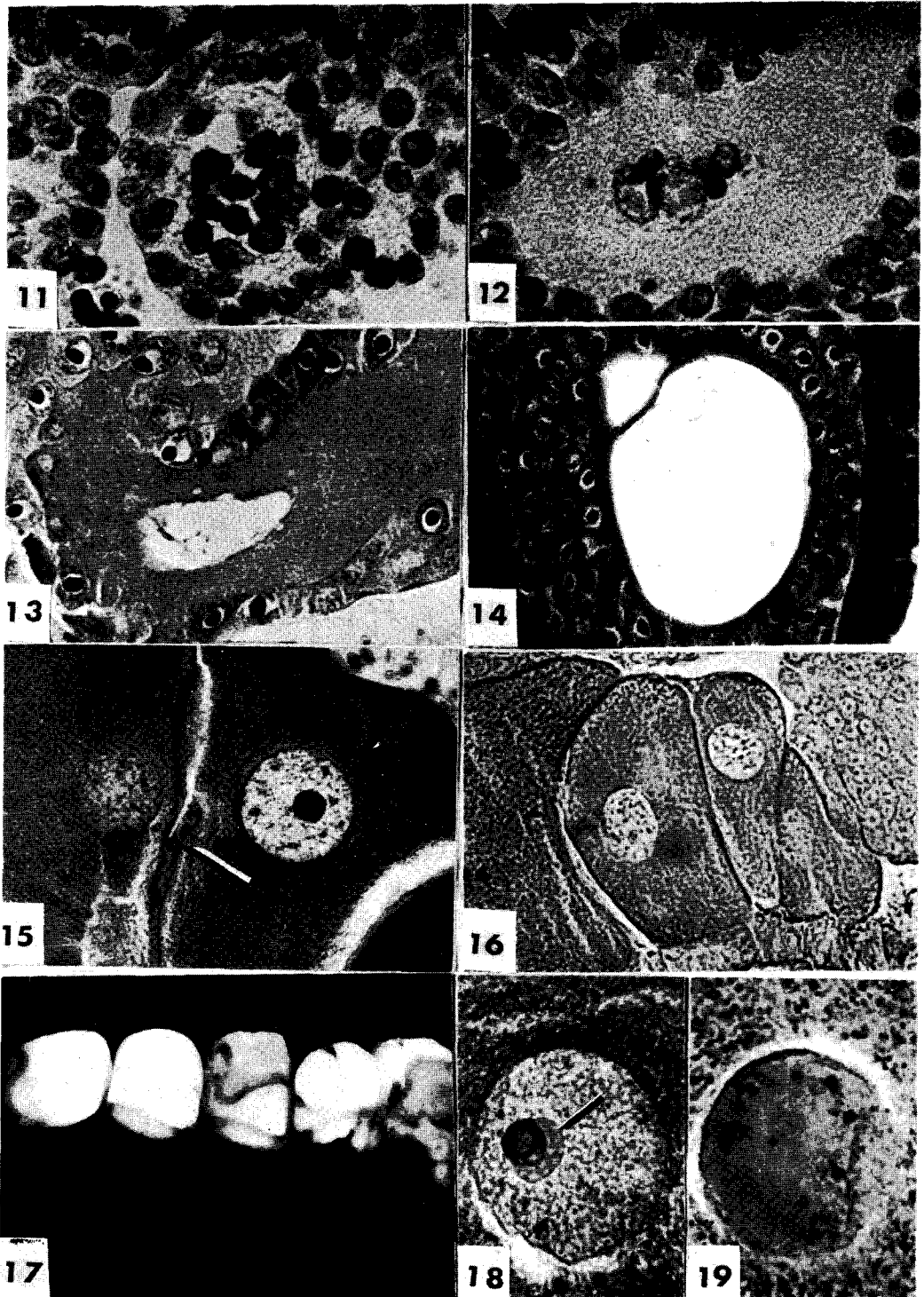

*Y. Hirao: Reproductive System and Oogenesis of Tubifex*

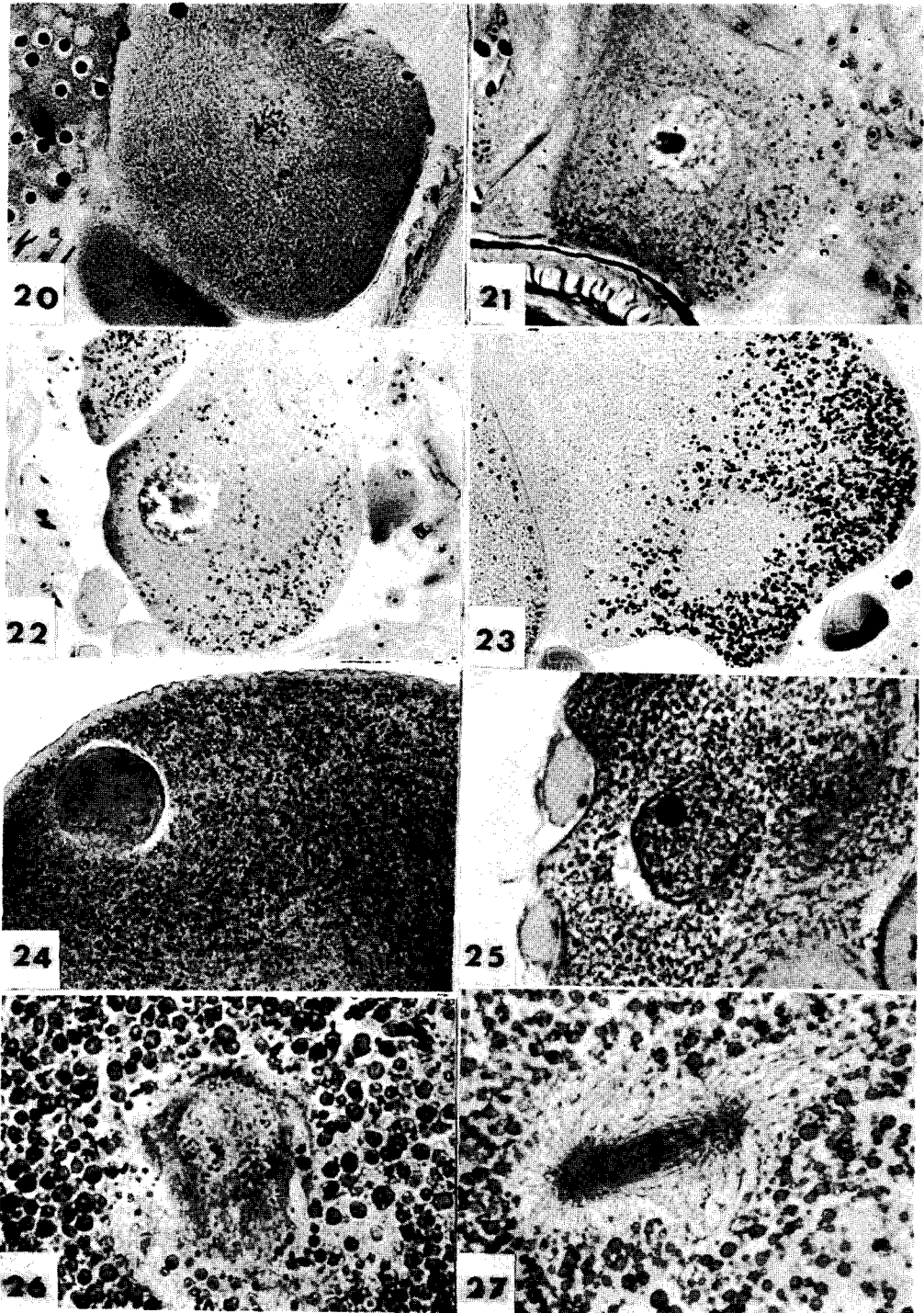

*Y. Hirao: Reproductive System and Oogenesis of Tubifex*