



HOKKAIDO UNIVERSITY

Title	Polychaetous Annelids from Shakotan (Hokkaido) : I. The Collection in 1967 (With 12 Text-figures and 1 Table)
Author(s)	UCHIDA, Hiro'omi
Citation	北海道大學理學部紀要, 16(4), 595-612
Issue Date	1968-12
Doc URL	https://hdl.handle.net/2115/27468
Type	departmental bulletin paper
File Information	16(4)_P595-612.pdf



Polychaetous Annelids from Shakotan (Hokkaido)

I. The Collection in 1967¹⁾²⁾

By

Hiro'omi Uchida

Zoological Institute, Hokkaido University

(With 12 Text-figures and 1 Table)

The fundamental investigations of the marine benthic fauna around Japan still remain imperfect, especially around Hokkaido. Fortunately the author had the opportunity on board the "Tankai-Maru", the research boat of Hokkaido Regional Fisheries Research Laboratory, Yoichi, and the survey of the benthic invertebrates off the coast of the Shakotan Peninsula is under way since October 1967.

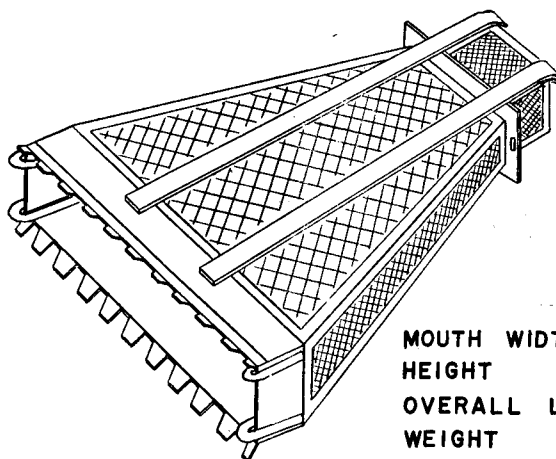

MOUTH WIDTH	102 cm
HEIGHT	27 cm
OVERALL LENGTH	170 cm
WEIGHT	200 kg

Fig. 1. The Takeuchi's Dredger.

The collections include many kinds of invertebrates from Porifera to Protochordata, among which polychaetes are now reported in this paper.

1) Contribution No. 828 from the Zoological Institute, Faculty of Science, Hokkaido University, Sapporo, Japan.

2) Studies on invertebrate fauna from west coast of Hokkaido I.
Jour. Fac. Sci. Hokkaido Univ. Ser. VI, Zool. 16, 1968.

The materials were dredged in October and December 1967 at the north coast off the Shakotan Peninsula in the region from $43^{\circ} 15.2'$ to $43^{\circ} 21.4' N.$ and from $140^{\circ} 35.2'$ to $140^{\circ} 56.4' E.$, and the depth ranged from 40 to 90 m. The Takeuchi's dredger (Fig. 1) was employed for the collections. The position, depth and bottom

Table 1. Sampling data of 1967

Station Number	Location		Date	Depth (m)	Bottom
	Latitude N.	Longitude E.			
1	$43^{\circ} 16.8'$	$140^{\circ} 41.3'$	X 3	76	Stone & Pebble
2	$43^{\circ} 17.5'$	$140^{\circ} 44.3'$	X 4	61	Sand
3	$43^{\circ} 20.5'$	$140^{\circ} 35.2'$	X 4	80	Mud & Sand
4	$43^{\circ} 18.0'$	$140^{\circ} 47.0'$	X 4	80-68	Sand
5	$43^{\circ} 15.2'$	$140^{\circ} 56.4'$	XII 7	40	Mud & Sand
6	$43^{\circ} 15.6'$	$140^{\circ} 46.2'$	XII 7	54	Fine sand
	$43^{\circ} 16.1'$	$140^{\circ} 48.9'$	XII 7		
7	$43^{\circ} 19.0'$	$140^{\circ} 41.3'$	XII 7	80	Pebble
8	$43^{\circ} 19.8'$	$140^{\circ} 44.4'$	XII 7	90	Rock
9	$43^{\circ} 20.6'$	$140^{\circ} 46.8'$	XII 7	90	Pebble & Mud
10	$43^{\circ} 21.4'$	$140^{\circ} 48.8'$	XII 7	90	Pebble
11	$43^{\circ} 18.6'$	$140^{\circ} 50.5'$	XII 12	70	Mud

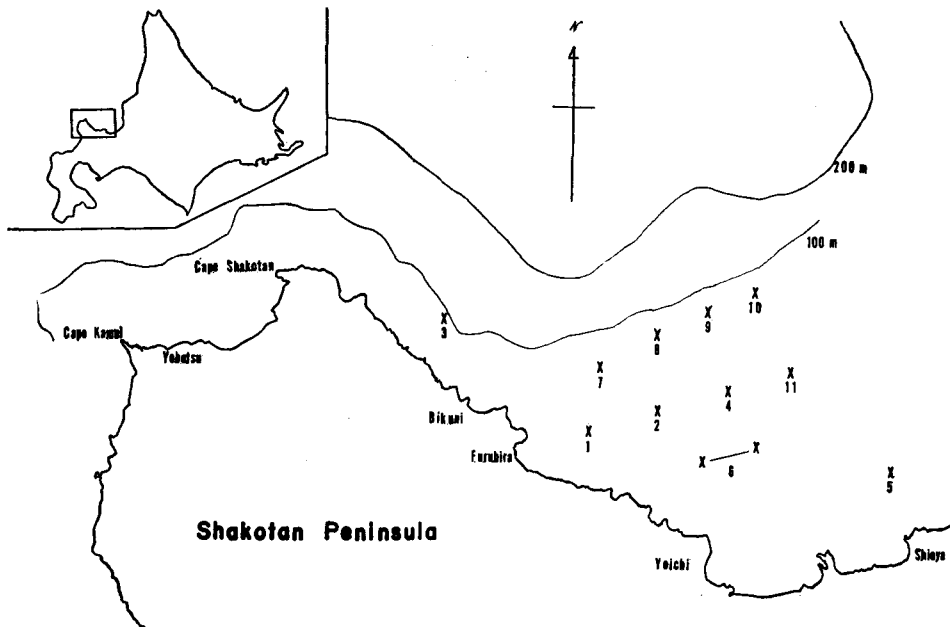

Fig. 2. The location of the stations.

nature of the stations are shown in Table 1 and Fig. 2. The dredgeings were made for 30 min. at each station while the boat had about two knot speed. The materials were preserved in 10% formalin. The nature of the bottom was determined by the sediments in the dredger at each station.

The collections include 16 species in 12 families. Among these species, 4 are of new record from Hokkaido, 1 is new to Japan, and 3 species including 1 genus are here described as new to science.

The following is the list of the species found in the present collection.

Family Polynoidae

- 1) *Harmothoë imbricata* (Linnaeus)

Family Nereidae

- 2) *Cheilonereis cyclurus* (Harrington)

Family Lumbrineridae

- 3) *Lumbrineris ezoensis* n. sp.

Family Arabellidae

- 4) *Arabella iricolor* (Montagu)

Family Cirratulidae

- 5) *Cirratulus afer* Ehlers

Family Flabelligeridae

- 6) *Pherusa plumosa* (Müller)

Family Opheliidae

- 7) *Travisia japonica* Fujiwara

Family Maldanidae

- 8) *Asychis shaccotanus* n. sp.

Family Pectinariidae

- 9) *Cistenides hyperborea* (Malmgren)

Family Telebellidae

- 10) *Spiroverma ononokomachii* n. g. n. sp.

Family Sabellidae

- 11) *Potamilla acuminata* Moore & Bush

- 12) *Sabella albicans* Johansson

- 13) *Sabellastarte zebuensis* (Mc Intosh)

- 14) *Chone teres* Bush

Family Serpulidae

- 15) *Serpula vermicularis* Linnaeus

- 16) *Eupomatus uncinatus* Philippi

All the specimens examined are deposited in the Zoological Institute, Faculty of Science, Hokkaido University.

The author expresses his hearty thanks to Dr. Saburo Kawata and Dr. Isamu Takeuchi of the Hokkaido Regional Fisheries Research Laboratory, who gave him an opportunity to go on board the "Tankai-Maru" and to examine the materials. He is also grateful to Prof. Mayumi Yamada and Dr. Shoichi F. Sakagami for their kind guidance throughout the course of the present study.

Description of the Species

Family POLYNOIDAE

Harmothoë imbricata (Linnaeus)

Polynoë (*Harmothoë*) *imbricata*: Marenzeller, 1879, p. 117, pl. 2, fig. 1.

Harmothoë imbricata: Izuka, 1912, p. 43, pl. 5, figs. 1-4, pl. 6, fig. 1; Okuda, 1935, p. 2; —, 1936, p. 563; Fauvel, 1936, p. 50; Annenkova, 1937, p. 151; Okuda, 1938a, p. 83; —, 1939, p. 224; Okuda & Yamada, 1954, p. 179; Uschakov, 1955, p. 156, fig. 38; Imajima, 1963, p. 350; Imajima & Hartman, 1964, p. 35.

Occurrence: St. 3, 1 spec.; St. 6, 1 spec.

One larger specimen from St. 6 measures 10 mm long for 39 setigerous segments, and 2.5 mm width at broadest part without parapodia. Prostomium has two pairs of eyes, the one pair under the anterior peaks. On the dorsal side there are 15 pairs of the vestiges with an elytron, only three elytra are remained.

Distribution: Europe; Arctic, north Pacific and Indian Oceans; cosmopolitan; Japan (Sakhalin to Kagoshima).

Family NEREIDAE

Cheilonereis cyclurus (Harrington)

(Fig. 3)

Nereis cyclurus: Johansson, 1901, p. 400, pl. 4, fig. 46, pl. 5, figs. 48-52; Ramsay, 1914, p. 237, fig. 1.

Nereis shishidoi: Izuka, 1912, p. 177, pl. 19, figs. 10-18; Zaks, 1933, p. 128; Annenkova, 1937, p. 163.

Cheilonereis cyclurus: Hartman, 1940, p. 219; —, 1948, p. 25; Okuda, 1950, p. 52; Uschakov, 1955, p. 213, fig. 67; Imajima & Hartman, 1964, p. 142.

Occurrence: St. 2, 3 spec.; St. 4, 1 spec.; St. 5, 6 spec.; St. 11, 1 spec.

The specimens are 14-65 mm by 1-3.7 mm without, and 2-7.5 mm with parapodia. The largest complete specimen from St. 5 has 117 setigerous segments. Prostomium has a pair of frontal antennae, and has two pairs of eyes on the posterior part. Palpi are large. Prostomium forming a characteristic collar, with the longitudinal wrinkles on its ventral and lateral sides, and have the dents on the middle ventral part. The four pairs of peristomial cirri are long and slender. In the parapodia, prosetal ligules come gradually longer and thinner to the anterior segments. The anal segment longitudinally wrinkled and has one pair of the long cirri.

One specimen from St. 5 has three peristomial cirri on left side, and it is probably a malformed one (Fig. 3-5). The most posterior cirrus is thicker than usual.

Distribution: Northern California to Alaska; Japan (Rikuzen, Oshoro).

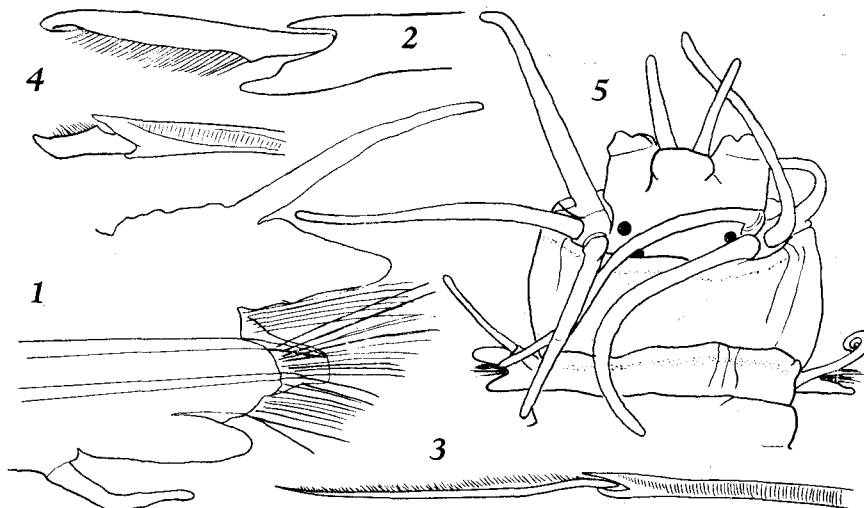

Fig. 3. *Cheilonereis cyclurus*. 1. 10th parapodium. $\times 30$; 2. Neuroseta in 5th parapodium. $\times 650$; 3. Notoseta in 10th parapodium. $\times 135$; 4. Neuroseta in 10th parapodium. $\times 135$; 5. Anterior region of the malformed specimen. $\times 12$.

Family LUMBRINERIDAE

Lumbrineris ezoensis n. sp.

(Fig. 4)

Occurrence: St. 2, 1 spec.

The specimen lacking posterior segments is 73 mm long for 143 setigerous segments, and 3 mm wide without, and 4 mm with parapodia. The prostomium is conical, and longer than wide, with no eyes (Fig. 4-1). The 6th and 7th setigerous segments are higher than the others. Simple winged limbate neurosetae are present from the first setigerous segment and continue through 44 segments; they are absent thereafter. But limbate notosetae are present from the first to 88th setigerous segment. Simple hooded hooks are present from the first to 143th segment in number 3-7, and they are increased in the segments of middle part and gradually decreased in number posteriorly. In both anterior and posterior segments, the postsetal lobes are longer than the presetal ones as same degree, and set upward to the presetal lobes (Figs. 4-3~5). In anterior segments each parapodium has many winged limbate setae.

This species resembles *L. heteropoda*, *L. brevicirra* and *L. zontata*, but differs from these three species by the shape of prostomium, the height of the 6th and 7th setigerous segments, and especially the number of segments with winged limbate neurosetae.

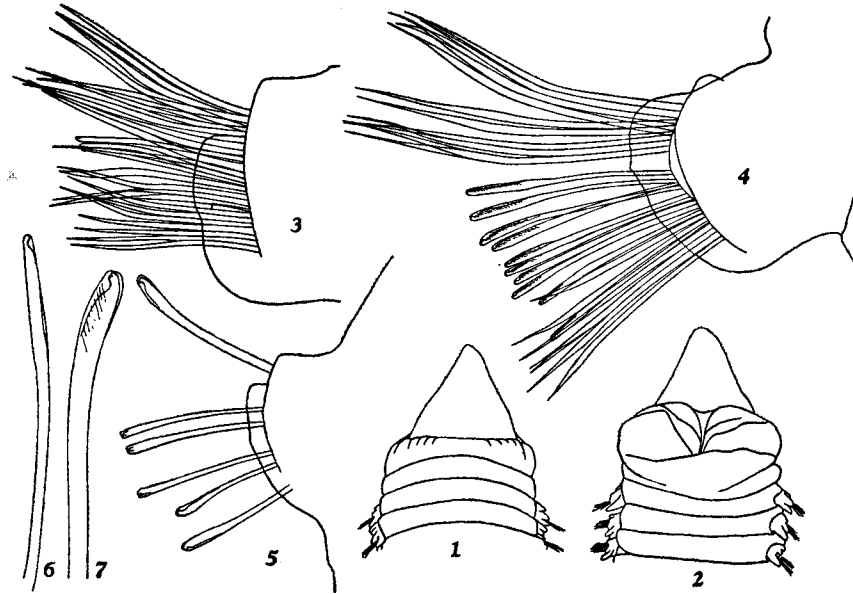

Fig. 4. *Lumbrineris ezoensis* n. sp. 1. Dorsal side of the prostomium and anterior segments. $\times 11$; 2. Ventral side of the same. $\times 11$; 3. 9th parapodium. $\times 20$; 4. 20th parapodium. $\times 20$; 5. 100th parapodium. $\times 20$; 6. Simple hooded hook in 20th parapodium. $\times 70$; 7. Simple hooded hook in 100th parapodium. $\times 70$.

Family ARABELLIDAE
Arabella iricolor (Montagu)
 (Fig. 5)

Arabella quadristriata: Ehlers, 1868, p. 339, pl. 17, figs. 15-24.

Arabella iricolor: Fauvel, 1936, p. 70; Okuda, 1938a, p. 97; —, 1939, p. 236; —, 1940, p. 18; Okuda & Yamada, 1954, p. 189; Ushakov, 1955, p. 244, fig. 81; Imajima & Hartman, 1964, p. 265.

Occurrence: St. 4, 2 spec.

Two specimens, one lacking posterior segments the other without anterior ones, were collected. Anterior one measures 27 mm for 80 segments, and posterior one 32 mm for 122 segments, and both 3 mm wide including parapodia. The prostomium is bluntly conical and has 4 eyes transversely arranged along posterior margin. Parapodia are of the same shape in anterior and posterior segments, and have prominent postsetal lobes (Figs. 5-1~2). Setae are limbate, and those of the superior group are geniculate, with strongly serrated convex margin (Figs. 5-3~4). Anal segment has a pair of short cirri.

Distribution: Atlantic, Pacific and Indian Oceans; cosmopolitan; Japan (Ryukyu Islands, Mitsui, Onagawa Bay and Matsushima Bay).

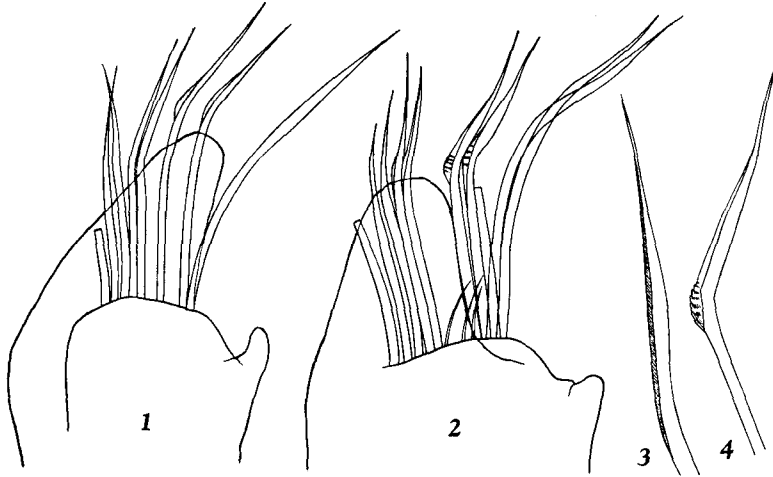

Fig. 5. *Arabella iricolor*. 1. 10th parapodium. $\times 75$; 2. 20th parapodium. $\times 75$; 3-4. Setae in 20th parapodium. $\times 130$.

Family CIRRATULIDAE

Cirratulus afer Ehlers

(Fig. 6-1)

Cirratulus afer: Ehlers, 1908, p. 127, pl. 17, figs. 10-12; Monro, 1930, p. 156, fig. 60.

Occurrence: St. 3, 1 spec.

The body is 35 mm long for prostomium and 58 anterior setigerous segments, and 4.5 mm wide. First 16 setigerous segments are rather crowded. Prostomium has no eyes. Dorsal tentacles, 8 on one side, are present on the first setigerous segment making a pair of bundles, a tentacle of each bundle rather thicker and with clear wrinkles on a side. Many branchiae are removed but each of the first, 5th, 7th, 8th, 15th and 20th segments has one branchia, and they are inserted just above the notopodia (Fig. 6-1). Parapodia have slender capillary setae only in both noto- and neuropodia.

The species is new to Japan.

Distribution: Africa.

Family FLABELLIGERIDAE

Pherusa plumosa (Müller)

Stylaroides borealis: Moore, 1903, p. 487.

Stylaroides plumosa: Okuda, 1937, p. 52, pl. 2, fig. c; Uschakov, 1955, p. 309, fig. 114.

Pherusa plumosa: Imajima & Hartman, 1964, p. 303.

Occurrence: St. 2, 1 spec.

The specimen is 32 mm in length for 53 segments, and 2 mm in width. Epithelial papillae are present all over the body surface, ventral papillae are smaller than dorsal ones. Oral apparatus has one pair of thick palpi and eight tentacles. Parapodia are rudimentary. The notosetae and neurosetae in the first three segments are very long and beyond the top of the body, forming the cephalic cage. From the fourth segment, neuropodial regions have sigmoid hooks, and notopodial ones have pointed setae.

Distribution: Atlantic and Pacific Oceans; cosmopolitan; Japan (North Japan, Onagawa Bay).

Family OPHELIIDAE
Travisia japonica Fujiwara
(Fig. 6-2)

Travisia japonica: Fujiwara, 1933, p. 91, pl. 1-2, textfigs. 1-11; Fauvel, 1936, p. 75; Uschakov, 1955, p. 324, fig. 120; Imajima & Hartman, 1964, p. 309.

Occurrence: St. 5, 1 spec.

The body is 54 mm long and 5 mm in maximum width and has 33 setigerous segments. The ventrum is absent in front. The first 20 setigerous segments have clearly three annulets separated by deep transverse grooves, not so clearly in the first segment. Next nine segments have two annulets but these are not so distinct, and more posterior segments have no grooves. The parapodia are rudimentary, with neurosetae and notosetae. Dorsal cirri present from the

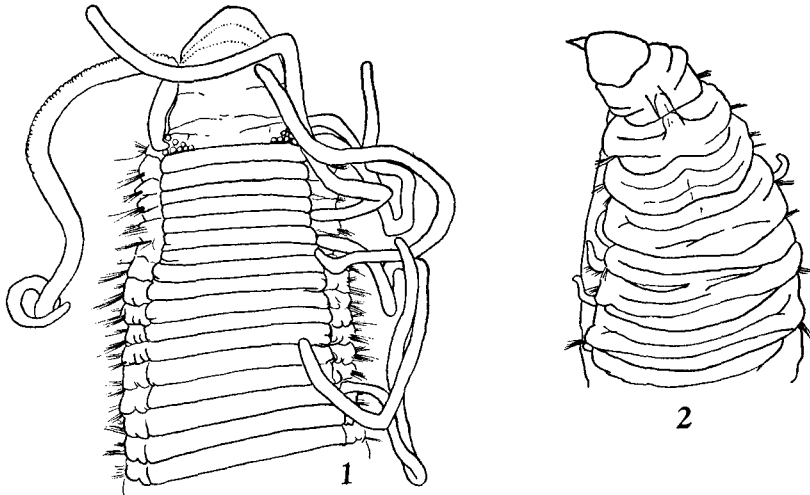

Fig. 6. 1. *Cirratulus afer*. Dorsal side of the anterior part. $\times 8$; 2. *Travisia japonica*. Dorsal side of the anterior part. $\times 5$.

second setigerous segment, and they vanish from 21st segment. In the 15th to 20th segments, the parapodia are well developed. The last segment and pygidium are damaged, so the structure of pygidium is not given.

This is a new record of the species from Hokkaido.

Distribution: China; Japan (Shikoku and Mie).

Family MALDANIDAE

Asychis shaccotanus n. sp.

(Fig. 7)

Occurrence: St. 1, 1 spec.; St. 3, 1 spec.; St. 11, 1 spec.

Two anterior parts and one posterior part are collected from three different stations. Two anterior parts measure 56 mm long for ten setigerous segments with 5 mm broad, and 17 mm long for four setigerous segments with the same width as the former one at the second segment.

The cephalic plate is elliptical and the surface has several lines arranged somewhat radially and is slightly elevated in the center. The rim is divided by a pair of lateral notches into a single posterior and paired lateral lobes, the posterior lobe is divided into 30 low lobes, in these lobes posterior 18 ones in central part are slightly thinner and lower than others and make pairs together with the neighboring lobes (Fig. 7-2). The lateral lobes divided into 9 long lobes. The cephalic keel is weakly developed (Fig. 7-1). The first setigerous segment has notosetae only, and notosetae and neuropodial hooks present from the second setigerous segment. The first notosetae consist of only smooth capillary setae (Fig. 7-3). The second setigerous segment has smooth and winged neuropodial setae and notopodial hooks with rounded main fangs (Fig. 7-6). Posterior neuropodia have three kinds of setae: smooth, winged and pennate capillary ones. The winged setae are conspicuously curved (Fig. 7-7). The posterior notopodial hooks have pointed bills (Fig. 7-10).

The posterior part, collected from St. 11, measures 29 mm for 6 segments with anal plaque, 4.5 mm width without and 6 mm with the parapodia. The dorsal lobe of pygidium is divided into two lobes (Fig. 7-12). The dorsal one is well developed and has six cirri on the rim, and forms a pocketlike process on the anal plaque. The neuro- and notosetae of these posterior segments (Figs. 7-13~14) are the same form as the ones in the anterior segments of *A. shaccotanus* n. sp., and the author can find no difference among the setae of these individuals.

The species resembles *A. disparidentata*, but clearly differs from it in the following characters; the number of lobes on posterior lobes, the structure of the cephalic plate and the rim of dorsal lobe.

setigerous segment. $\times 80$; 8. Pennate capillary seta in the same segment. $\times 18$; 9. Basal part of the same seta. $\times 330$; 10. Notopodial hook of the same segment. $\times 150$; 11. Posterior part. $\times 6$; 12. Pygidium. $\times 6$; 13. Neuroseta in last setigerous segment. $\times 18$; 14. Notopodial hook in the same segment. $\times 150$.

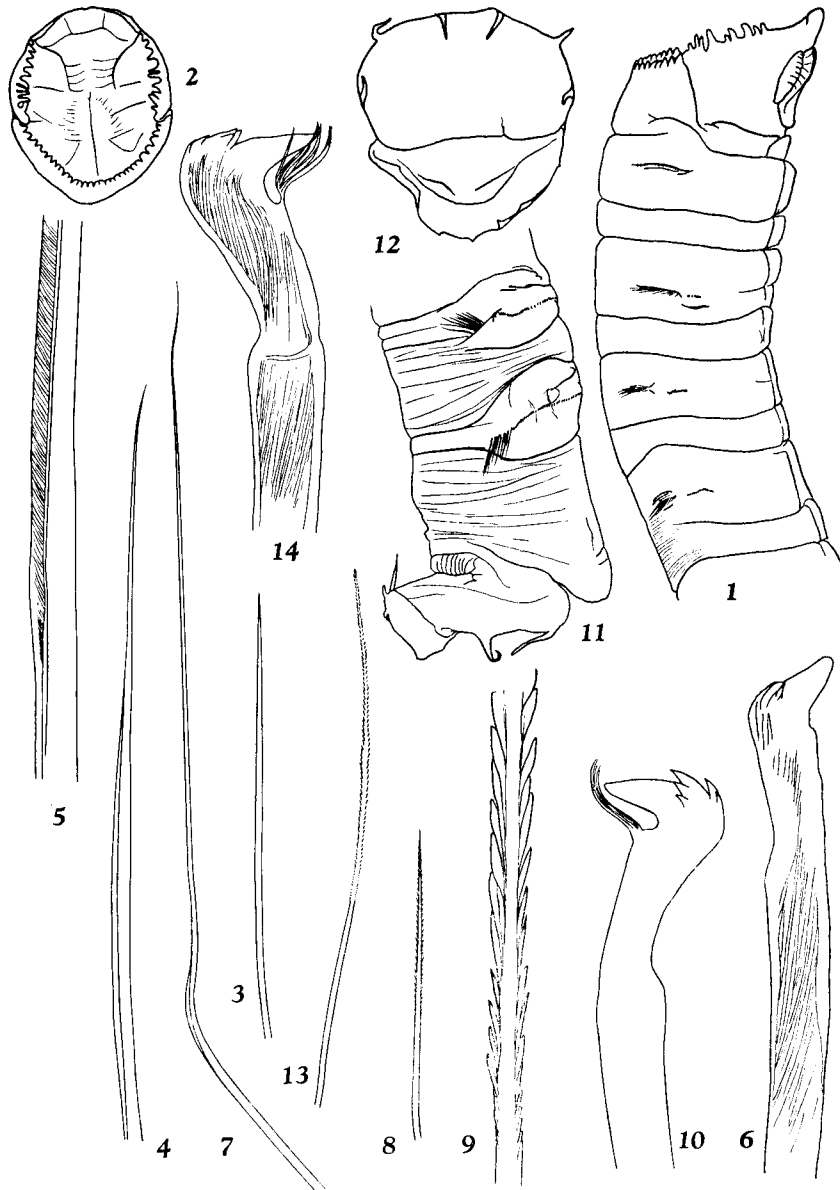

Fig. 7. *Asychis shaccotanus* n. sp. 1. Lateral side of the anterior part. $\times 5$; 2. Cephalic plate. $\times 5$; 3. Smooth capillary notoseta in the first setigerous segment. $\times 150$; 4. Winged neuroseta in the second setigerous segment. $\times 80$; 5. Basal part of the same seta. $\times 150$; 6. Notopodial hook in the second setigerous segment. $\times 150$; 7. Winged neuroseta in 9th

Family PECTINARIIDAE
Cistenides hyperborea (Malmgren)
 (Fig. 8)

Cistenides hyperborea: Moore, 1903, p. 479; Imajima & Hartman, 1964, p. 327.

Pectinaria (Cistenides) hyperborea: Nilsson, 1928, p. 31, textfig. 9; Annenkova, 1929, p. 484, pl. 37, fig. 11, pl. 38, figs. 25-31; Okuda, 1937, p. 56, pl. 2, fig. F, textfig. 5; Uschakov, 1955, p. 359, figs. 131, 133.

Pectinaria (Cistenides) hyperborea pacifica: Nilsson, 1928, p. 31, textfigs. 9 a-b.

Occurrence : st. 3, 1 spec.; St. 11, 1 spec.

Two complete specimens measure 31 mm, 21 mm long each, and both 5 mm wide at cephalic parts. The cephalic spines are 12 in number on each side. The antennular membrane has 28 papillae (Fig. 8-1). Dorsal border of cephalic plate is smooth. There are 17 setigerous segments, and 12 uncinigerous segments present from the fourth setigerous segment. Notosetae are of two kinds, winged and denticulated (Figs. 8-2~3). Uncini have three or four large teeth and four or five small ones above the basal process (Fig. 8-4). The scapha has six lobes on each side. Anal ligule with a smooth edge and a small cirrus in the center. Scaphal hooks are eight on each side.

Distribution: North Atlantic Ocean; Arctic boreal regions; Japan (Sendai Bay, Onagawa Bay and Mamiya Channel).

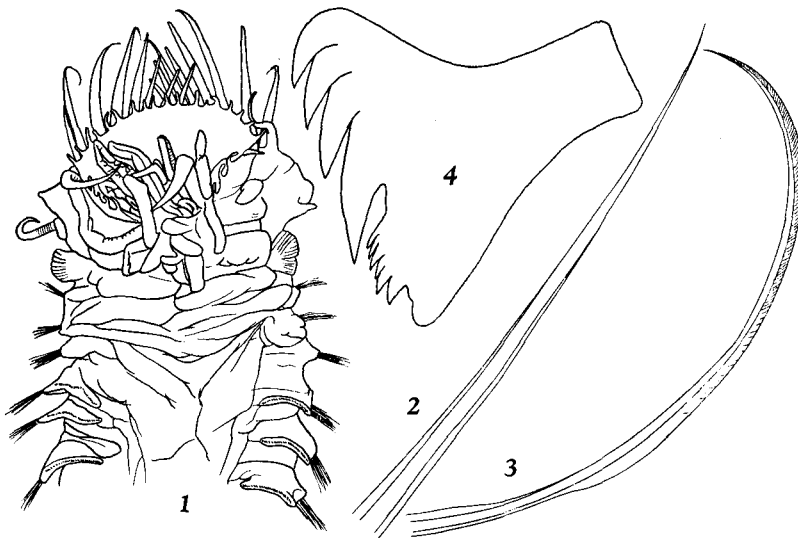

Fig. 8. *Cistenides hyperborea*. 1. Cephalic part. $\times 6$; 2. Winged notoseta in 9th setigerous segment. $\times 150$; 3. Denticulated notoseta in the same segment. $\times 150$; 4. Uncinus in the same segment. $\times 800$.

Family TELEBELLIDAE
Spiroverma new genus

The body is strongly spiraled. Prostomium has eye spots at the both sides of the peristomium. Tentacles have longitudinal grooves. One pair of bundled branchiae are at the second segment. There are 17 thoracic segments. Notosetae appear from the second segment and neuropodial uncini from the third segment.

Type species *S. ononokomachii* n. sp.

The genus *Spiroverma* resembles *Scinoella* Moore (1903), or *Amphitrite* Müller (1771), but *Spiroverma* has a pair of branchiae on the second segment, and notosetae present from the second segment and neurosetal uncini present from the third segment. Moreover, the shape of the uncini of *Spiroverma* differs from that of *Amphitrite*. The new genus belongs to Amphitritinae.

Spiroverma ononokomachii n. sp.

(Fig. 9)

Occurrence: St. 1, 2 spec.

One complete individual and one posterior part of this species were collected. In the complete individual, the body is 33 mm long and 2 mm wide at the thoracic segments; it has 79 segments and is indistinctly divided into thoracic and abdominal regions. The prostomium is prominent, and projects out stiffly above and at the side of the mouth. There are many eye spots at the both sides of the peristomium. Each tentacle has a longitudinal groove (Figs. 9-1~2). The lateral

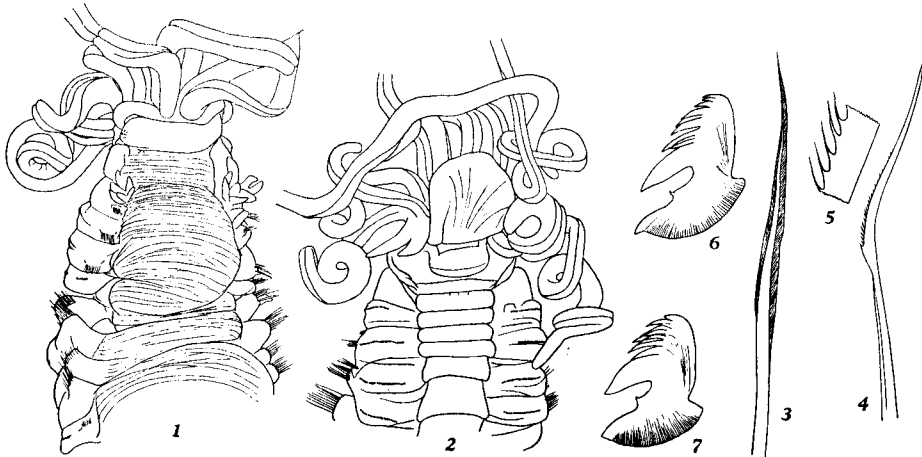

Fig. 9. *Spiroverma ononokomachii* n.g. n. sp. 1. Dorsal side of cephalic part. $\times 45$; 2. Ventral side of cephalic part. $\times 45$; 3. Notoseta in the second setigerous segment. $\times 300$; 4. Abdominal notoseta. $\times 300$; 5. Denticulate part of the same seta. $\times 820$; 6. Uncinus in 5th setigerous segment. $\times 820$; 7. Uncinus in 13th setigerous segment. $\times 820$.

lobes are conspicuous in the anterior segments. A single pair of branchial tufts are on the inner border of the lateral lobes on the second segment, each consisting of eight short simple filaments.

The dorsum from the second to the fifth segment rises conspicuously, and rises again from 10th segment and this continues throughout the anterior segments gradually being inconspicuous. The thorax has 17 setigerous segments. Notosetae present from the second segment, and neurosetal uncini from the third segment. Notopodial setae and neuropodial uncini on the first four setigerous segments are present on more ventral side on more posterior segment. From 60th segment, the body becomes rapidly slender. Anal segment is thick and has four rifts on its posterior rim. Thoracic notosetae are limbate, and abdominal notosetae are distally dentate (Figs. 9-3~5). Uncini of all segments are of the same shape, and have some transverse rows of teeth above the main fangs (Figs. 9-6~7).

Family SABELLIDAE

Potamilla acuminata Moore & Bush

(Fig. 10)

Potamilla acuminata: Moore & Bush, 1904, p. 159, pl. 11, figs. 3-6, pl. 12, fig. 41; Imajima & Hartman, 1964, p. 359.

Occurrence: St. 5, 1 spec.

One complete specimen was collected and has 45 mm long including 5 mm tentacular crown for 92 segments, and 2 mm wide at thoracic segments. Radioles number 18 and 19, each slightly twisted and without eye spots. The collar is remarkable in ventral to notosetal ridge. The ventral part of each segment has a brownish, broadly flat process. The throax consists of eight setigerous segments. Thoracic neuropodia have avicular uncini and pennoned setae. The thoracic notopodia have two kinds of setae, limbate and slender. Abdominal neurosetae consist of only slender ones with a bend on 1/3 from the ends.

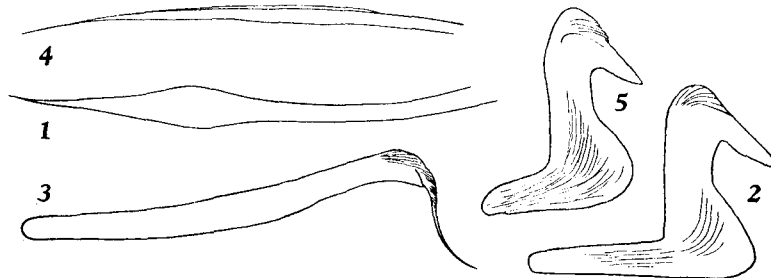

Fig. 10. *Potamilla acuminata*. 1. Thoracic notoseta in 6th segment. $\times 150$; 2. Thoracic neuropodial uncinus in the same segment. $\times 230$; 3. Thoracic neuropodial pennoned seta in the same segment. $\times 230$; 4. Abdominal neuroseta in 15th segment. $\times 160$; 5. Abdominal uncinus in the same segment. $\times 230$.

This is a new record of the species from Hokkaido.

Distribution: Japan (Sagami Bay).

***Sabella albicans* Johansson**

(Fig. 11)

Sabella albicans: Johansson, 1922, p. 4, pl. 1, fig. 7, pl. 3, figs. 7-9; Okuda, 1938b, p. 129; Imajima & Hartman, 1964, p. 362.

Occurrence: St. 10, 1 spec.

Only one complete individual have 19 mm long with 6 mm crown and 21 setigerous segments, and 1 mm wide at the thoracic region. The thorax has 8 segments. Radioles number 9 pairs; they are completely separated. The dorsal lobes of the collar are very small. The lateral and ventral lobes are not separated and well developed. The ventral plates are well developed. The first thoracic notosetae are all of capillary form with limbus on one side (Fig. 11-1), and the other thoracic segments have short capillary setae, broadly limbate (Figs. 11-2~3). Thoracic neurosetae are of two kinds, avicular and pennoned (Figs. 11-4~5). The abdominal uncini are similar to those in the thoracic segments (Fig. 11-6).

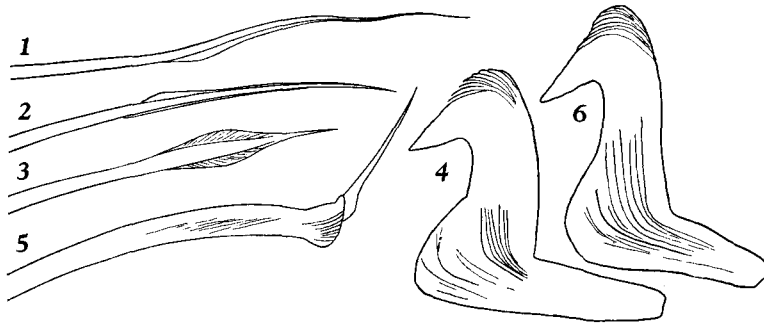

Fig. 11. *Sabella albicans*. 1. The first thoracic notoseta. $\times 160$. 2. Thoracic notoseta in 5th segment. $\times 160$; 3. Thoracic notoseta in the same segment. $\times 160$; 4. Neuropodial avicular seta in 5th thoracic segment. $\times 560$; 5. Neuropodial pennoned seta in the same segment. $\times 560$; 6. Abdominal uncinus. $\times 560$.

The specimen well agrees with the description of Johansson, and also with that of Okuda except in the account of the thoracic neurosetae. It was pointed out by Imajima and Hartman (1964).

This is a new record of the species from Hokkaido.

Distribution: Japan (Misaki and Ise Sea).

***Sabellastarte zebuensis* (Mc Intosh)**

(Fig. 12)

Sabella zebuensis: Mc Intosh, 1885, p. 487, pl. 52, fig. 2, pl. 29A, figs. 20-22.

Sabellastarte zebuensis: Johansson, 1927, p. 155; Imajima & Hartman, 1964, p. 364.

Sabellastarte bocki: Okuda, 1938b, p. 130, textfig. 8.

Occurrence : St. 10, 1 spec.

The specimen, damaged at some parts of radioles, has 20 mm long, of which the crown is 10 mm long, and 1mm wide at thoracic region. There are eight thoracic setigerous and 47 abdominal segments. Radioles number 17 pairs, and have nine purple spots, without eyes and stylodes. The collar is bilobed, and its dorsal part is separated widely, and its ventral lobes are thick and large triangular. Thoracic notosetae are limbate and gradually shorter and broader (Figs. 12-1~2). Thoracic neuropodial uncini are avicular only. The taxonomic characters of the specimen all agree with the descriptions by Mc Intosh, Johansson and Okuda except for the radioles number.

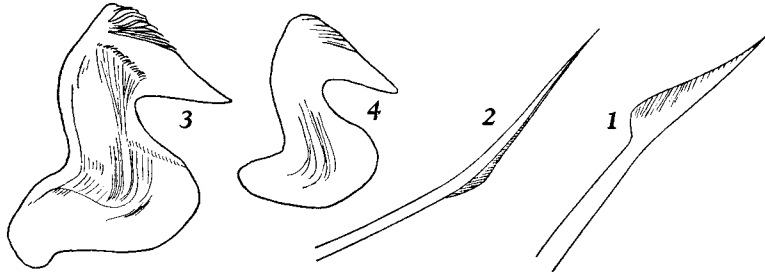

Fig. 12. *Sabellastarte zebuensis*. 1-2. Notosetae in the third segment. $\times 160$; 3-4. Thoracic neuropodial uncini in the third segment. $\times 550$.

This is a new record of the species from Hokkaido.

Distribution: Philippine Islands; Japan (Misaki and Ise Sea).

Chone teres Bush

Chone teres: Bush, 1904, p. 215, pl. 30, fig. 1, pl. 37, figs. 16-23; Okuda, 1934, p. 236, textfigs. 3-4; Imajima & Hartman, 1964, p. 365.

Occurrence: St. 10, 1 spec.

The complete specimen is collected. The body is 26 mm long for only 50 setigerous segments and 10 mm long for the branchial crown, and 1 mm wide at thoracic region. Posterior end is very gradually tapered, without ventral groove. The branchial crown consists of 11 pairs of radioles, each radiole is connected for the most part with the neighboring ones with thin films. The collar is about twice as high as the first segment. The first eight setigerous segments compose the thorax. The first segment has only two rows of notosetal fascicles. There are notosetae and neurosetae from the second thoracic segment. The thoracic notosetae are of three kinds, limbate capillary, spatulate and bayonet-shaped. The thoracic neurosetal uncini have a long shaft with about ten small denticles

above the main fang. Abdominal neurosetae are limbate capillary form with two bends in opposite directions, and notopodial uncini with no shaft and with five to six rows of teeth in side view.

Distribution: Alaska; northern Japan (Akkeshi and Muroran).

Family SERPULIDAE

Serpula vermicularis Linnaeus

Serpula granulosa: Marenzeller, 1884, p. 215, pl. 4, fig. 1.

Serpula columbiana: Johnson, 1901, p. 432, pl. 19, figs. 199-204.

Serpula splendens: Bush, 1904, p. 230, pl. 16, fig. 3, pl. 29, fig. 2, pl. 30, figs. 2-3, pl. 33, fig. 31, pl. 35, fig. 18, pl. 37, fig. 31, pl. 39, fig. 33.

Serpula vermicularis: Okuda, 1940, p. 22; Hartman, 1948, p. 47; Uschakov, 1955, p. 424, fig. 160; Imajima & Hartman, 1964, p. 372.

Occurrence: St. 1, 4 spec.; St. 7, 10 spec.; St. 10, 3 spec.

The largest specimen from St. 1 has 75 mm long for 250 segments, and 3 mm wide at thoracic region. Radioles number 31 pairs. The operculum has a simple funnel with 28 serrations. The thorax has seven setigerous segments. Collar setae are of two kinds, smooth capillary and bayonet-shaped.

Distribution: Atlantic, Indian and Pacific Oceans; cosmopolitan; Japan (Enoshima, Kagoshima and Ryukyu Islands).

Eupomatus uncinatus Philippi

Hydroides (Eupomatus) fusicola: Möreh, 1868, p. 374; Augener, 1925, p. 18.

Hydroides uncinata: Okuda, 1937, p. 63, textfig. 10; —, 1938a, p. 104; Uschakov, 1955, p. 427, fig. 161.

Eupomatus uncinatus: Ehlers, 1887, p. 285, pl. 58, figs. 6-11; Imajima & Hartman, 1964, p. 368.

Occurrence: St. 2, 3 spec.; St. 5, 8 spec.; St. 6, 5 spec.

The body is 17-60 mm long, of which the radioles are 5-7 mm. The thorax has 7 and the abdomen 73-125 setigerous segments. Radioles number 16 pairs. In the most largest specimen from St. 5, opercular lower funnel with 32 pointed spines, upper one with 16 tall spines all alike or accompanied by a different spine. Collar notosetae are of two kinds, bayonet-shaped with two short basal processes and slender capillary. Thoracic uncini have a row of six or seven teeth.

Distribution: Atlantic and Pacific Oceans; Mediterranean Sea; cosmopolitan; Japan (Onagawa Bay and Mitsui).

References

- Annenkova, N.P. 1929. Beiträge zur Kenntnis der Polychaeten-Fauna der USSR. I. Ann. Mus. Zool. Acad. Sc. URSS **30**: 477-502, pls. 37-39.
 ———— 1934. Kurze Uebersicht der Polychaeten der Litoralzone der Bering-Insel (Kommandor-Inseln), nebst Beschreibung neuer Arten. Zool. Anz. **106**: 322-331.

- 1937. Fauna Polychaeta severnoi chasti Iâponskogo Moriâ. Akad. Nauk SSSR, Issledovaniâ morei SSSR **23**: 139–216, pls. 1–5.
- Bush, K.J. 1904. Tubicolous annelids of the tribes sabellides and serpulides from the Pacific Ocean. Harriman Alaska Exped. **12**: 169–355, pls. 21–44.
- Ehlers, E. 1864. Die Borstenwürmer (Annelida Chaetopoda) nach systematischen und anatomischen Untersuchungen. Leipzig, 268pp., 11 pls.
- 1897. Polychaeten. Ergebnisse der Hamburger Magalhaensischen Sammelreise **3**: 1–148, pls. 1–9.
- 1908. Die bodensässigen Anneliden aus den Sammlungen der Deutschen Tiefsee-Expedition. Wiss. Ergeb. D. Tiefsee-Expedition **16**(1), pp. 1–167, 23 pls.
- Fauvel, P. 1934. Sur quelques syllidiens du Japon. Annot. Zool. Japon. **14**: 301–315.
- 1936. Annelides polychètes du Japon. Mem. Coll. Sci. Kyoto Univ. ser. B. **12**: 41–92.
- Fujiwara, T. 1933. On a new species of Japanese Polychaeta, *Travisia japonica* sp. nov. Jour. Sci. Hiroshima Univ. ser. B, Zool. **2**: 91–103, 2 pls.
- Grube, A.E. 1878. Annulata Semperiana. Mem. Akad. Nauk SSSR (7), **25**(8): 1–300, 15 pls.
- Hartman, O. 1940. Polychaetous annelids. Part II. Chrysopetalidae to Goniadidae. Allan Hancock Found. Pacif. Exped. **7**: 173–287, pls. 31–44.
- 1942. The identity of some marine annelid worms in the United States National Museum. Proc. U.S. Natl. Mus. **92**: 101–140.
- 1948. The polychaetous annelids of Alaska. Pac. Sci. **2**: 1–58.
- 1959. Catalogue of the polychaetous annelids of the world. Allan Hancock Found. Occas. Pap. **23**: 1–628.
- Hessle, C. 1917. Zur Kenntnis der Terebellomorphen Polychaeten. Zool. Bidr. Uppsala **5**: 39–258, pls. 1–5.
- Imajima, M. 1963. Polychaetous annelids collected off the west coast of Kamchatka. II. Notes on species found in the collection of 1959. Publ. Seto Mar. Biol. Lab. **11**: 175–202, pls. 12–15.
- and O. Hartman 1964. The polychaetous annelids of Japan. Allan Hancock Found. Occas. Pap. **26**: 1–452, pls. 1–38.
- Izuka, A. 1912. The errantiate Polychaeta of Japan. Jour. Coll. Sci. Tokyo Univ. **30** (2): 1–262, 24 pls.
- Johansson, K.E. 1922. On some new tubicolous annelids from Japan, the Bonin Islands and the Antarctic. Ark. Zool. **15** (2): 1–11, 4 pls.
- Johnson, H.P. 1901. The Polychaeta of the Puget Sound region. Proc. Boston Soc. Nat. Hist. **29**: 381–437, pls. 1–19.
- McIntosh, W.C. 1885. Report on the Annelida Polychaeta collected by H.M.S. Challenger during the years 1873–76. Challenger Rpts, Zool. **12**: 554pp. pls. 1–55, 1A–39A.
- Marenzeller, E. 1879. Südjapanische Anneliden. I. Denkschr. Akad. Wiss. Wien, Math.-Naturwiss. Kl **41** (2): 109–154, pls. 1–6.
- 1884. Südjapanische Anneliden. II. Ibid. **49** (2): 197–224, pls. 1–4.
- Monro, C. 1930. Polychaeta worms. Discovery Rpts. **2**: 1–222.
- Moore, J.P. 1903. Polychaeta from the coastal slope of Japan and from Kamchatka and Bering Sea. Proc. Acad. Nat. Sci. Philad. **55**: 401–490, pls. 23–27.
- 1923. The polychaetous annelids dredged by the U.S. Steamer “Albatross” off the coast of southern California in 1904. IV. Ibid. **75**: 179–259, pls. 17–18.
- and K.J. Bush 1904. Sabellidae and Serpulidae from Japan, with descriptions of new species of *Spirorbis*. Ibid. **56**: 157–179, pls. 11–12.

- Nilsson, D. 1928. Neue und alte Amphicteniden. Göteborgs Vetensk. Handl. (4) **33** (4): 1-96.
- Okuda, S. 1934. Some tubicolous annelids from Hokkaido. Jour. Fac. Sci. Hokkaido Univ. ser. VI, Zool. **3**: 233-246.
- 1936. Japanese commensal polynoids. Annot. Zool. Japon. **15**: 561-571.
- 1937. Annelida Polychaeta in Onagawa Bay and its vicinity. I. Polychaeta Sedentaria. Sci. Rpts. Tohoku Univ. ser. 4, Biol. **12**: 45-69, pl. 2.
- 1938a. Polychaetous annelids from the vicinity of the Mitsui Institute of Marine Biology. Japan. Jour. Zool. **8**: 75-105.
- 1938b. Polychaetous annelids from the Ise Sea. (In Japanese) Dobutsugaku Zasshi **50**: 122-131.
- 1939. Annelida Polychaeta in Onagawa Bay and its vicinity. II. Polychaeta Errantia with some addenda of Polychaeta Sedentaria. Sci. Rpts. Tohoku Univ. ser. 4, Biol. **14**: 219-244.
- 1940. Polychaetous annelids of the Ryukyu Islands. Bull. Biogeogr. Soc. Japan **10**: 1-24.
- 1950. Notes on some commensal polychaetes from Japan. Annot. Zool. Japon. **24**: 49-53.
- and M. Yamada 1954. Polychaetous annelids from Matsushima Bay. Jour. Fac. Sci. Hokkaido Univ. ser. VI, Zool. **12**: 175-199.
- Ramsay, L.N.G. 1914. On the annelids of the Family Nereidae collected by Mr. F.A. Potts in the N.E. Pacific, in 1911. Proc. Zool. Soc. **17**: 237-250.
- Uschakov, P. 1955. Mnogoschetinkovye chervi dal' nevestochnykh Morei SSSR (Polychaeta). Akad. Nauk SSSR, Zool. Inst., Opredeleteli po Faune SSSR **56**: 445 pp.
- Zachs, I. 1933. Faune Kol'chalykh chervi Severo-Iaponskogo Moriâ (Polychaeta). Akad. Nauk SSSR, Zool. Inst., Issledovaniâ morei SSSR **19**: 125-137.
-