



HOKKAIDO UNIVERSITY

Title	The Life-History of <i>Clytia edwardsi</i> (Hydrozoa; Campanulariidae) in Hokkaido, Japan (With 14 Text-figures, 23 Tables, and 1 Plate)
Author(s)	KUBOTA, Shin
Citation	北海道大學理學部紀要, 21(3), 317-354
Issue Date	1978-12
Doc URL	https://hdl.handle.net/2115/27641
Type	departmental bulletin paper
File Information	21(3)_P317-354.pdf



The Life-History of *Clytia edwardsi* (Hydrozoa; Campanulariidae) in Hokkaido, Japan

By

Shin Kubota

Zoological Institute, Hokkaido University

(With 14 Text-figures, 23 Tables, and 1 Plate)

It is well-known that polyps of *Clytia* liberate medusae of *Phialidium*. Kramp (1961) reviewed the species of the genus *Phialidium* and enumerated 25 species of the genus which have been described from the different seas of the world. On the other hand, a large number of *Clytia*-species, about three times as many as *Phialidium*-species, have been described from the world. It is not easy, therefore, to connect the species of polyp to that of medusa, and the classification within these genera remains confused. In the present paper, the whole life-history of *Clytia edwardsi* (Nutting) in Hokkaido is described, and this is an outcome from studies on Japanese hydroids carried out by the author to clarify the relationships between polyp and medusa generations.

Material and Methods

Polyps with gonangia of this species were collected from Oshoro facing the Japan Sea, and from Muroran and Akkeshi facing the Pacific Ocean, in Hokkaido, northern Japan. The polyps from Oshoro and Muroran were collected by skin diving and those from Akkeshi were by dredging, and all these colonies inhabited the subtidal zones within a depth of 5 m. The description of the present species is mostly based on the materials shown in Table 1, and the abbreviations for materials in the Table are used in the following context.

The methods of rearing of medusae and of observations are as follows. The youngest medusae, which were liberated from the polyp in the laboratory soon after taking from the sea (within a few days), were reared in the covered glass-vessels (6.0×4.5 cm, 6.0×8.0 cm, and 8.5×9.0 cm: height × diameter) filled with fresh and clean sea water supplied from Oshoro Bay until they attained mature. In most of the examinations, the water temperature for rearing of medusa was kept at about 12°C because the mean water temperature in Oshoro Bay is known as 12.3°C for ten years of 1948–1967. The medusa was fed with newly hatched *Artemia*

Table 1. Materials used for description, showing collected data and rearing conditions.

MA	Collecting date of polyp	Collecting station of polyp	Substratum of polyp	DS	WT	C	RP	TR	Wa	Sex
Cla	27-X-'75	Shamodomari, Oshoro Bay	brown alga (<i>Sargassum</i> sp.)	2	13.8	1	60	16	F-S	♂
Clb	6-XI-'75		ditto		12.0	1	—	—	—	—
Clc	21-XI-'75		ditto		8.4	2	15	16	F-S	—
Cld	21-V-'76		ditto		11.9	—	—	—	—	—
Cle	24-V-'76		ditto		11.4	4	90	12	F-S, F	♂
Clf	2-VI-'76		ditto		12.4	—	—	—	—	—
Clg	24-VI-'76		ditto		15.6	—	—	—	—	—
Clh	2-VI-'77		ditto		15.2	1	45	12	F	♀
C2	30-VII-'76	Cave in open shore, Oshoro	brown alga	0.5	21.6	2	60	12, 23	F	♂, ♀
C3	9-VII-'76	Barasan Point, Akkeshi Bay	red alga (<i>Laingia pacifica</i>)	5	14.0	1	60	12	F	♂
C4	12-VIII-'76	Denshin-Hama, Muroran	red alga; hydroid (<i>Abietinaria costata</i>)	0.5	16.7	1	45	12	F	♀

MA: abbreviation for material DS: depth of substratum (m)

WT: water temperature of collecting station (°C), Oshoro: at 9:00 a.m.; Muroran and Akkeshi: at 10:00 a.m. C: number of colonies reared

RP: approximate rearing period of medusa (days) TR: water temperature for rearing of medusa (°C)

Wa: medium for rearing of medusa, F: filtered sea water; F-S: filtered and sterilized sea water

nauplii, and they were given to medusa sufficiently once a day. For the youngest medusa which could not eat the swimming *Artemia* nauplii by itself, the food was torn into pieces and was given by hands with the aid of needles. All the medusae could eat by themselves within a few days after liberation. In a rearing container a few or several medusae are kept. During the stay in Akkeshi from July 10 to 19, 1976, the sea water from Akkeshi Bay were used for C3 and the medusa was fed with plankton animals.

Fig. 1 shows the schematic illustration of the life-history of the present hydroid and indicates various body portions which were examined and described. The abbreviations in the figure are used in the following context. All the characters in polyp except for T were measured on the specimens preserved in formalin, while the count for T was on the living specimens. The measurements of all the body portions of medusa were made on the living specimens under the starved and well-relaxed conditions, after anesthetized with 8% MgCl₂ solution. After transferred the medusa into a petri-dish by a pipet with wide mouth, W, S, L, GL, GW, V, J, M, and H were measured under binocular microscope with the aid of

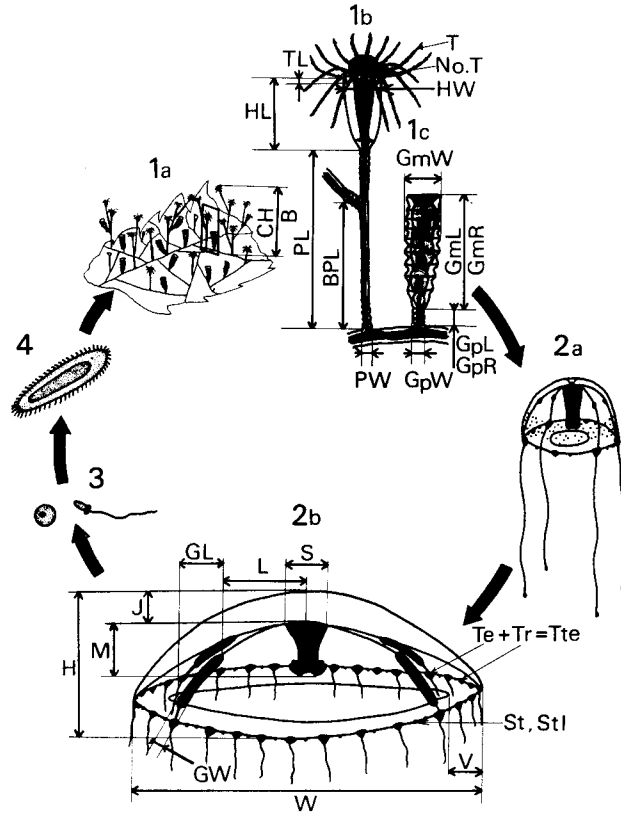

Fig. 1. A schematic illustration of the life-history of the present hydroid, showing abbreviations of measurements of various body portions of polyp and medusa examined. 1a: a colony of polyp, CH: colony height, B: maximum number of branching in a colony; 1b: a part of colony with a zooid and a branch, HL: length of hydrotheca, HW: maximum width of hydrotheca, TL: length of tooth, No. T: number of tooth, T: number of tentacles, PL: length of pedicel or branch, PW: maximum width of pedicel or branch, BPL/PL: growing point of branch; 1c: a gonangium containing medusa-buds, GmL: length of gonangium excluding of stalk, GmR: number of corrugations of gonangium excluding of stalk, GmW: maximum width of gonangium, GpL: length of stalk of gonangium, GpR: number of annulations of stalk of gonangium, GpW: maximum width of stalk of gonangium; 2a: a newly liberated medusa within one day after liberation; 2b: a mature medusa about one month old, L: length from center of stomach to proximal portion of gonads, GL: length of gonads, GW: maximum width of gonads, S: breadth of stomach, W: width of umbrella, V: breadth of velum, M: length of manubrium, J: thickness of jelly at umbrellar apex, H: height of umbrella, Te: number of well-developed tentacles, Tr: number of marginal warts, Tte: total number of well-developed tentacles plus marginal warts, St: number of statocysts, Stl: number of statoliths, (L, GL, GW, S, W, V: aboral view; M, J, H: side view).

needles. Then the medusa was transferred onto a deep-hole slide glass, and Te, Tr, Tte, St, and Stl were counted from the oral side of medusa in clockwise order in every quadrant under the microscope. The measurements are shown in the following order: minimum-mean-maximum value, and the number of specimens measured (shown in parentheses). After the measurements, the medusa was restored to the rearing container. A large number of *Artemia* nauplii were given after the medusa began to swim actively. When the medusa ate them up, it was transferred into the newly-set containers. Drawings such as Figs. 2-4, 9-10, 11(A), and 13-14 were done with the aid of a drawing apparatus.

Description of Polyp and Development of Gonangium

The colonial polyps were found growing on various substrata such as some algae, other hydroids, some gastropod or mussel shells, and the rope of fishing-net (Plate VII, 1). Various body portions of polyp which are shown in Fig. 1, 1a and 1b were measured. A number of pieces of colony and their zooids included in them were examined (Table 2), and their measurements are shown in Tables 3-4.

The general description of polyp is as follows. The polyp (Fig. 2) is unbranched or branched several times (up to 4) in a colony, and reaching a height of 12 mm. The pedicels and branches are variable in length (up to 5.6 mm), while nearly constant in width, and are usually annulated at their distal ends (5-13 in number for 9 zooids of Cla) and proximal ends (6-11 for 18 zooids of Cla), and some of them are annulated in their whole length. One to three branches arise from a single pedicel or a branch at once, and each young branch grows out from the distal half of the older one (Table 3, BPL/PL).

The hydrotheca is campanulate in shape, with triangular teeth on the margin (Fig. 2, F-H). The teeth are up to about 100 μ in length (mean ca. 50 μ) and up to 12 in number. The hydrotheca is variable in size, up to 933 μ in length and 397 μ in width, and the distinct difference of hydrothecal size is found between Cla and Clg. The hydrotheca is about twice as deep as wide and the shape is nearly constant regardless of its size (HL/HW). The lower part of hydrotheca is narrowed and a simple diaphragm is demarcated from the hydrothecal wall, separating off a basal chamber (70-99-140 μ in length for 13 zooids of Cla). The teeth were absent in some of hydrothecae. No ridges are present in hydrotheca.

The mouth opens on a trumpet-shaped hypostome on which nematocysts of one kind are present. The zooids were inclined to possess mostly 20 or 22 filiform tentacles in a single whorl (Table 4). It was observed that 16 tentacles were present in 9 young polyps of Cla which were asexually produced on the newly extended stolon attached to a petri-dish in laboratory. When the tentacles are extended, they are alternately arranged elevated and depressed. Nematocysts of one kind are present on the tentacles. The polyp is milky-white in color and periderm is sometimes brownish. On the polyp colony collected from Oshoro Bay, the larvae or adults of pycnogonids were sometimes found.

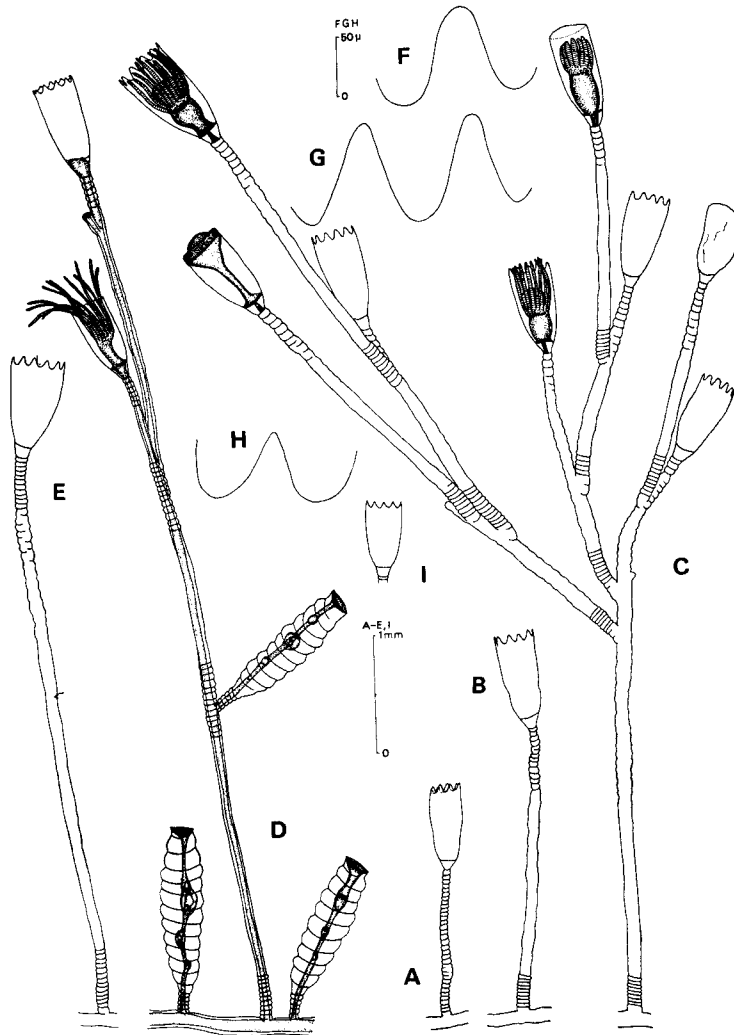

Fig. 2. Several parts of polyp colony (A-C, F-G: C1; D-E: collected from Oshoro Bay, 17-VI-1976, on a green alga, *Ulva*; H-I: C2). A, B, and E: unbranched zooid, C: a part of colony with the third branches (coenosarc abridged), D: a part of colony with a branch, 2 zooids and 3 gonangia, F-H: hydrothecal teeth, I: a hydrotheca.

Various portions of gonangium which are shown in Fig. 1, 1c were examined, and the measurements are shown in Table 5. The gonangium is borne directly on the creeping stolon, sometimes near the base of pedicel, on the axils of the branches, and on the pedicels or branches directly. The shape of gonangium of

the colony which was collected directly from the sea is all elongated elliptical with several (up to 11) strong transverse corrugations (Fig. 2, D; Fig. 3, C, D; Plate VII, 2). The distal end of gonangium is nearly truncated. The proximal part of it becomes gradually slender and continues into a short stalk (up to 0.34 mm in length) in which several (up to 10) annulations are present. Most of the stalks are straight, but some are curved. One gonangium contains several (up to 8) medusa-buds of different growths. The medusa-buds are not equal in size in a gonangium, usually the distal one is most developed. The size of gonangium excluding its stalk is much variable, up to 1.3 mm in length, 0.44 mm in width, and the shape is somewhat variable (Table 5, GmL/GmW). On an upright grown portion of a colony which is branched four times, 14 or more trophozooids and 4 gonangia were found. It was observed that the number of gonangia was few in C4, only 1 in C4.1 and 4 in C4.2, and most of them were empty when the polyps were collected.

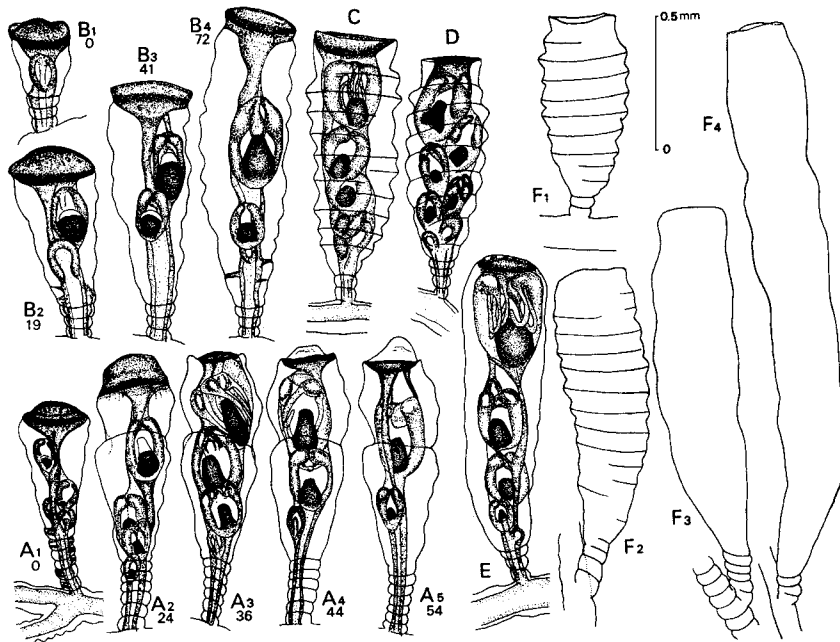

Fig. 3. Gonangia. A₁-A₅, B₁-B₄: development of gonangia in the laboratory, numerals under the capitals indicate the time passed after A₁ or B₁ in hours respectively (A: produced on branch, Cla; B: on stolon, Clc); C (Cla) and D(C2): gonangia on stolon, produced in the sea; E(Cla) and F₁-F₄ (C2): gonangia newly produced in the laboratory, E and F₁: gonangia on stolon, F₂-F₄: gonangia on pedicel or branch.

A considerable morphological variability was exhibited in the gonotheca between the gonangia produced in the natural sea and those produced under culture conditions. In most of the newly produced gonangia especially on pedicels

Table 2. Number of pieces of polyp colony examined.

MA \ B	0	1	2	3	4	Total
Cl _a	5 (5) ¹⁾	3 (5)		2 (12)	1 (10)	11 (32)
Cl _d	2 (2)		4 (10)			6 (12)
Cl _g	2 (2)	4 (6)				6 (8)
Cl _h	13 (13)	2 (4)		1 (3)		16 (20)
C2	2 (2)	2 (4)		1 (8)	1 (14)	6 (28)
C3	3 (3)	2 (4)	1 (4)	1 (3)	1 (6)	8 (20)
C4.1 ²⁾	3 (3)	2 (4)	2 (4)			7 (11)
C4.2 ³⁾	9 (9)					9 (9)

1): figures in parentheses show the number of zooids counted

2): colony on a red alga

3): colony on the other hydroid, *Abietinaria costata*

Table 3. Measurements of various body portions of polyp.

MA	CH (mm)	B	PL (mm)	PW (μ)	HL (μ)	HW (μ)	HL/HW	No. T	BPL/PL
Cl _a	12.0	4	1.1-2.4-5.3 (33)	58-89-98 (33)	653-741-933 (21)	268-322-397 (21)	2.1-2.3-2.6 (21)	8-9.4-12 (14)	0.39-0.66-0.91 (23)
Cl _d	8.1	4	1.1-2.0-3.0 (12)	70-96-117 (11)	560-615-700 (11)	268-288-327 (11)	1.9-2.1-2.3 (11)	8-9.2-10 (5)	—
Cl _g	7.2	2	0.9-2.1-2.9 (8)	70-77-82 (5)	490-554-618 (8)	187-232-257 (8)	2.1-2.4-2.6 (8)	8-8.3-10 (7)	0.43-0.43-0.43 (2)
Cl _h	3.8	3	1.1-2.0-3.3 (20)	—	438-519-688 (20)	188-256-281 (20)	1.8-2.0-2.4 (20)	7-9.4-10 (5)	0.30-0.44-0.53 (4)
C2	10.3	4	1.0-2.3-5.6 (28)	70-84-93 (11)	420-602-723 (14)	257-307-350 (14)	1.6-1.9-2.2 (14)	8-10.4-12 (10)	0.63-0.75-0.90 (23)
C3	9.5	4	0.7-1.5-2.4 (17)	82-106-117 (13)	467-569-747 (15)	245-280-350 (15)	1.8-2.0-2.3 (15)	8-9.3-10 (10)	0.42-0.53-0.72 (5)
C4.1	8.3	2	1.4-2.9-4.1 (11)	70-85-98 (11)	478-582-723 (10)	245-276-303 (10)	1.9-2.1-2.3 (10)	8-8.4-10 (8)	0.37-0.52-0.66 (2)
C4.2	8.0	1	1.4-2.8-4.0 (9)	70-82-93 (9)	420-583-782 (9)	210-249-292 (9)	2.0-2.3-2.7 (9)	6-7.8-10 (8)	—

Table 4. Number of tentacles of polyp.

MA	T																No. of zooids examined
	12	13	14	15	16	17	18	19	20	21	22	23	24	25	26		
C1h	2	0	0	0	1	0	4	0	6	0	3					16	
C2					1	0	3	0	10	0	7	1	6	0	2	30	
C3							3	0	1	0	4	0	0	0	2	10	
C4.1					3	0	2	0	8	0	2	1	2			18	
C4.2			1	0	1	1	1	0	1	0	1					6	

Table 5. Measurements of various portions of gonangia (mm).

MA	No. G ¹⁾	GmL	GmW	GmL/GmW	GmR	GpL	GpW	GpR
C1a	18S ²⁾ +2P ³⁾ (F) ⁴⁾	0.84-1.03-1.13*	0.31-0.34-0.38	2.7-3.0-3.4**	ca. 10	—	—	4-4.6-6
C1c	5S(L) ⁵⁾	1.06-1.15-1.19*	0.25-0.26-0.28	4.2-4.5-4.8**	wavy	—	—	3-3.4-4
C1c	11P(L)	1.13-1.30-1.56*	0.25-0.28-0.31	3.6-4.7-5.6**	smooth	—	—	3-3.6-6
C1d	5S+5P(F)	0.97-1.09-1.25	0.34-0.36-0.39	2.6-3.0-3.6	7-9.3-11	0.09-0.11-0.16	0.06-0.08-0.09	2-2.8-4
C1g	10S(F)	0.75-0.97-1.22	0.26-0.35-0.41	2.1-2.8-3.3	5-8.2-11	0.06-0.10-0.13	0.05-0.07-0.09	3-3.8-4
C1h	13S(F)	0.75-0.92-1.06	0.31-0.36-0.44	2.2-2.5-2.8	6-7.9-9	0.03-0.13-0.19	0.06-0.09-0.13	2-3.9-7
C2	10S+5P(F)	0.66-0.75-0.84	0.25-0.30-0.33	2.1-2.5-3.0	5-7.1-9	0.06-0.11-0.16	0.05-0.06-0.08	2-3.2-4
C2	9S(L)	0.56-0.70-0.81	0.28-0.33-0.38	1.8-2.1-2.7	5-6.7-8	0.06-0.12-0.31	0.06-0.08-0.09	2-3.4-7
C2	7P(L)	1.03-1.39-1.94	0.31-0.32-0.33	3.3-4.3-6.2	smooth	0.09-0.15-0.22	0.06-0.08-0.11	2-4.1-7
C3	8S+4P(F)	0.69-1.02-1.31	0.34-0.38-0.44	1.8-2.6-3.3	5-7.1-10, wavy	0.09-0.21-0.34	0.09-0.11-0.13	3-5.3-10
C3	4S(L)	0.84-0.87-0.91	0.34-0.36-0.38	2.3-2.4-2.5	6-7.3-8	0.13-0.18-0.28	0.09-0.10-0.11	4-4.5-6
C4.1	1S(F)	0.72	0.25	2.9	5.0	0.13	0.09	4.0
C4.2	4S(F)	0.59-0.63-0.66	0.28-0.29-0.30	2.1-2.2-2.2	7-7.5-8	0.09-0.13-0.16	0.06-0.08-0.09	3-3.0-3

*: GmL+GpL **: (GmL+GpL)/GmW value

1): number of gonangia examined 2): gonangia produced on stolon 3): gonangia produced on pedicel or branch

4): gonangia produced in the sea 5): gonangia newly produced in the laboratory

or branches under culture conditions, the distinct transverse corrugations are absent, namely their gonothecal wall was nearly smooth; moreover their length was fairly longer than that of gonangia produced in the natural sea as are shown in Fig. 3, E, F₃, and F₄; Table 5, Clc-11P(L), C2-7P(L). Their size are up to 1.94 mm in length and 0.38 mm in width. On the other hand, it was observed that many of the newly produced gonangia on stolon in laboratory were nearly equal to those produced in the natural sea as are shown in Fig. 3, F₁; Table 5, Clc-5S(L), C2-9S(L), and C3-4S(L).

A part of a colony containing a very young gonangium and several trophozooids was cut off and was reared in a petri dish in order to observe the further development of the gonangium (Fig. 3, A₁-A₅ and B₁-B₄). The complete development of a gonangium was found within about several days. Then the thin lid of gonangium opened and the medusae in it were liberated one by one from the distal one at some intervals (see Fig. 3, A₄).

Metamorphosis of Medusa

The process of the metamorphosis of medusa was observed in detail for the materials from Oshoro Bay. The first examination was made on the same specimens of Cl_a, which were observed every other day in order to learn the outline of this process. In the examination of Cl_e, a large number of the youngest medusae, which were soon liberated from 4 polyp colonies at the same time (25-V-'76), were reared and their various body portions were measured every seven days for two months, picking up 15-20 ones on each observation (Table 6).

1) *Description of Newly Liberated Medusa*

In this paper, the newly liberated medusa means the youngest one within one day after liberation from the polyp, consequently consisting of different aged medusae from 0 to 24 hours after liberation. Their size may be, therefore, vary to some extent due to the rapid growth of the medusa. To ascertain it, 5 medusae of Cl_c were examined when they were just liberated and precisely 24 hours after liberation. Their measurements are:

0 hr.: W=0.56-0.62-0.66 mm, H=0.38-0.40-0.44 mm, M=0.13-0.13-0.13 mm

24 hr.: W=0.81-0.84-0.94 mm, H=0.56-0.61-0.63 mm, M=0.19-0.19-0.22 mm

As was expected, the youngest medusa just liberated increased its size during successive 24 hours.

The general description of the newly liberated medusa is as follows (see Tables 6 and 15): The umbrella is bell-shaped and is slightly wider than high (Fig. 4; Plate VII, 3). The umbrellar width and height are up to 1.1 mm and 0.75 mm respectively. The jelly is fairly thin, uniform in thickness and about 1/10 of the height of umbrella, and a depression is found at the apex of umbrella. Nematocysts of one kind are present on exumbrella. Most of these nematocysts, which are characteristic of the young medusa, are arranged forming a horizontal

Table 6. Measurements of various body portions on

Age (days)	1	7	14	21
No. of medusae examined	20	18	18	15
L	—	0.60-0.82-1.15	1.19-1.63-1.90	1.75-2.22-2.86
GL	0.04-0.05-0.08	0.10-0.20-0.22	0.32-0.43-0.63	0.32-0.77-1.11
GW	0.02-0.03-0.04	0.08-0.13-0.20	0.16-0.20-0.24	0.13-0.18-0.29
M	0.19-0.23-0.28	0.40-0.54-0.65	0.48-0.66-0.79	0.63-0.74-0.79
S	0.08-0.09-0.10	0.22-0.31-0.40	0.40-0.53-0.63	0.56-0.65-0.79
J	0.03-0.04-0.05	0.30-0.37-0.45	0.56-0.64-0.71	0.79-0.88-0.95
W	0.69-0.89-1.06	2.10-2.54-3.50	4.29-5.16-5.87	6.03-7.16-8.41
H	0.50-0.58-0.75	1.00-1.34-1.60	1.75-2.04-2.70	2.06-2.48-3.02
V	0.13-0.17-0.19	0.30-0.33-0.40	0.40-0.55-0.79	0.63-0.81-0.95
Te	4-4-4	4-7-8	13-16-17	16-16-18
Tr	3-4-4	8-10-12	1-6-14	5-9-14
Tte	7-8-8	16-16-17	16-21-27	21-25-31
St	8-8-8	8-8-9	16-18-23	22-25-30
Stl	7-8-9	7-8-9	17-21-29	24-34-43

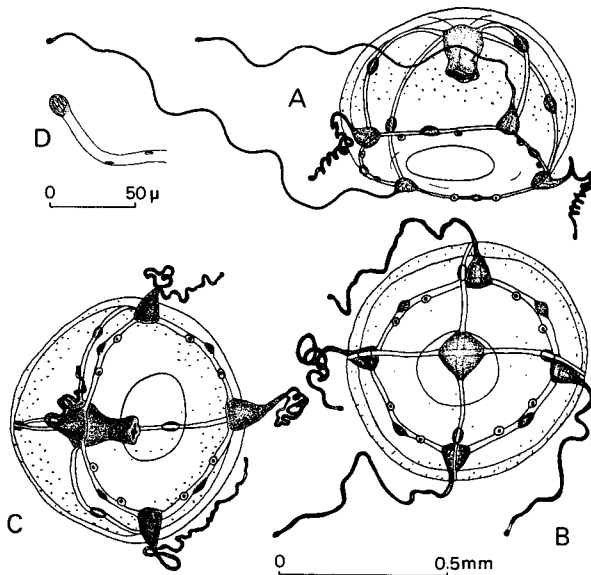

Fig. 4. A-C: newly liberated medusae within one day after liberation, D: distal end of tentacle showing nematocyst cluster (A and D: Clc; B-C: Cle).

band on the surface of the distal half of the exumbrella, but some of them are also found around the radial canals. The tubular manubrium is relatively short and about $2/5$ of the umbrellar height. The stomach is nearly quadrate and about $1/5$

various developmental stages of medusa, Cle (in mm).

28	35	42	63
15	18	19	5
2.22-2.46- 3.02	2.46- 2.81- 3.33	2.38-2.76- 3.49	3.81- 3.97- 4.13
0.63-1.38- 1.90	0.79- 1.70- 2.54	0.48-1.28- 1.98	0.79- 0.81- 0.87
0.19-0.31- 0.35	0.19- 0.32- 0.40	0.24-0.30- 0.32	0.32- 0.33- 0.40
0.79-0.81- 0.95	0.79- 0.85- 0.95	0.79-0.84- 0.95	0.79- 0.90- 0.95
0.71-0.84- 1.03	0.71- 0.97- 1.27	0.79-0.96- 1.27	0.79- 0.83- 0.95
0.95-1.11- 1.27	1.11- 1.28- 1.59	1.11-1.37- 1.59	1.27- 1.27- 1.27
8.25-8.73-10.32	8.57-10.14-11.75	8.61-9.14-10.16	9.84-10.19-10.63
2.54-3.21- 3.81	3.33- 4.19- 4.76	2.70-4.11- 4.92	5.40- 5.52- 5.56
0.79-1.01- 1.43	0.95- 1.12- 1.43	0.87-1.18- 1.67	1.59- 1.59- 1.59
16-18-22	16-19-24	17-20-25	19-21-22
2-9-14	4-9-16	5-9-15	8-10-13
24-27-30	24-28-32	26-29-32	30-31-32
27-29-31	28-31-35	29-32-35	34-34-35
29-37-59	29-35-47	29-35-44	39-41-46

of the umbrellar width. There are indistinct 4 oral lips, on which nematocysts of one kind are present. There are 4 straight and smooth radial canals. A small oval swellings of gonads is already situated on the middle of each radial canal. There are 4 perradial well-developed and long marginal tentacles. They are up to 25 times as long as the umbrellar height in well-extended condition. Nematocysts of two kinds are present on tentacles. Each tentacle possesses a small swelling at the distal end (Fig. 4, D; Plate VII, 4) in which nematocysts of one kind are present. But nematocysts are seldom found on the small distal part of the tentacles near the swelling. Four small interradial marginal warts without tentacles are present. There are 8 adradial statocysts as closed marginal vesicles, each containing a single spherical statolith. The statocysts are slightly dislocated from the precise adradia towards the interradia. The velum is broad and about 1/2 of the bell-aperture. Stomach and tentacular bulbs are reddish brown in color. An abnormal youngest medusa was found in Clb, and it possessed 5 radial canals, 6 statocysts, 3 well-developed tentacles, and 2 marginal warts.

2) Development of Umbrella

Successive developmental change of the umbrella in Cla is shown in Fig. 5. The umbrellar width and height of 20 newly liberated medusae are 0.50-0.58-0.69 mm and 0.31-0.42-0.50 mm respectively. The umbrellar width increases day by day, but it increases with the considerable rapidity during the period from the 12th to 19th day. On the other hand, the growth of the umbrellar height is not so conspicuous as that of the width. About one month after liberation their increase nearly stops. The umbrellar width becomes 15 or more times as wide as that of newly liberated medusa, attaining about 10 mm (Fig. 5, W), while the umbrellar

height attains 2.5 mm, 5 or more times (Fig. 5, H). It was observed that the growth of umbrellar width of Cle is nearly the same as that of Cla. In Cle the umbrellar width attains about 12 mm, while the umbrellar height is nearly twice as high as Cla, attaining 5.5 mm.

Developmental change of umbrellar form results as the combination of umbrellar width and height. The change in Cla is as follows. The umbrellar form becomes flattened with age because of the rapid growth of the umbrella in circular direction as is shown in Fig. 5, U1-U5, in which the umbrellar height is depicted

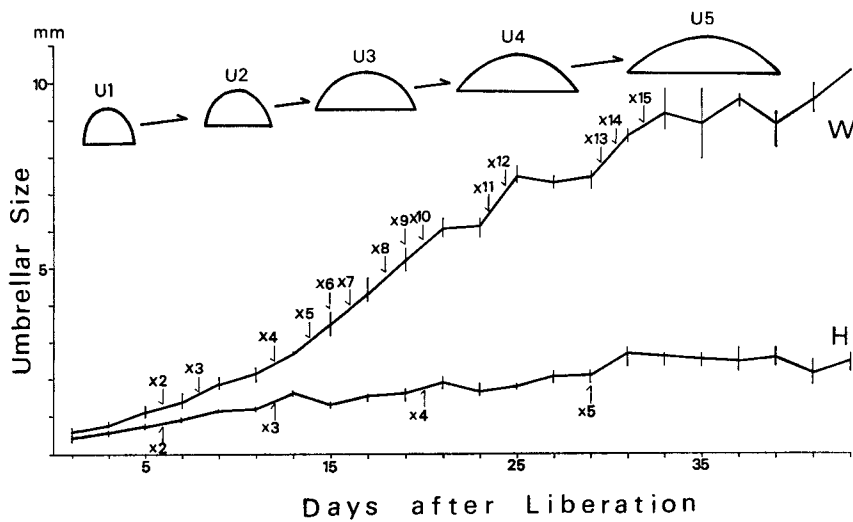

Fig. 5. Successive change of umbrellar form (U1-U5), of umbrellar width (W), of umbrellar height (H) in the development of medusa (Cla). Numerals with arrows indicate ratios of umbrellar size to that of newly liberated medusae.

in equal height for comparison. Accordingly the umbrellar form of mature medusa becomes watch-glass-shaped. About one month after liberation the umbrellar form becomes fixed and the ratio between the umbrellar height and width is nearly 1:4. As the umbrellar height is higher in Cle, the umbrella form is nearly hemispherical and the ratio between the umbrellar height and width is nearly 1:2.

The newly liberated medusa possesses a depression at the apex of the umbrella as a vestige of detachment from the gonangium. This depression remains apparently for about two weeks. Then it gradually disappears, and 21 days after liberation only its trace remains on some of the medusae. The umbilical canal occurs together with the depression as a vestige of the connection with gonangium, and it also gradually disappears together with the depression. The exumbrellar nematocysts are probably not newly produced after the medusa is liberated from the polyp, and they gradually disappear as medusa grows. The presence of the

depression of umbrella and umbilical canal as well as the exumbrellar nematocysts are characteristic of young medusa.

The jelly increases its thickness as medusa grows, especially at the apex of the umbrella. About one month after liberation the growth of jelly stops, attaining 1.6 mm in maximum thickness in Cle, and about 1 mm in Cla. The ratio between the thickness of jelly at the apex of the umbrella and the umbrellar height in mature medusa of Cle is 1:3-4, and about 1:2.5 in Cla.

The velum is wide and the bell-aperture is $\frac{3}{5}$ of the umbrellar width in the newly liberated medusa in Cle. The velum becomes wider as medusa grows, and about one month after liberation the growth of it stops, attaining 0.9-1.6 mm in breadth and 7-10 times as wide as that of newly liberated medusa. The bell-aperture, however, is considerably wide and $\frac{7}{10}$ - $\frac{8}{10}$ of the umbrellar width, because of the considerable increase of the umbrella towards the circular direction. The maximum breadth of velum attains 1.7 mm in Cle, and 1.4 mm in Cla.

3) *Development of Stomach and Manubrium*

The stomach grows larger and finally the development of stomach stops about one month after liberation, attaining 0.7-1.3 mm in breadth and nearly 11 times as large as that of newly liberated medusa. The ratio between the breadth of stomach and the umbrellar width is constant in whole developmental stages of medusa of Cle, namely 1:10. The stomach becomes cross-shaped in mature medusa.

The manubrium becomes longer, and its development in Cle stops about one month after liberation, attaining 0.8-1.0 mm in length and nearly 4 times as long as that of the newly liberated medusa. The oral lips gradually become distinct as medusa grows and they make a fold (Fig. 9, D; Plate VII, 7) and recurve slightly in mature medusa. The manubrium becomes funnel-shaped. In the development of stomach and oral lips, perradial corners of them spread out. The position of oral lips in the subumbrellar cavity in side view is not always equal during the whole developmental stages of medusa. The oral lips are situated at nearly middle of umbrellar height in both the newly liberated medusa and the mature medusa, while they are situated near the bell-aperture in younger medusa. But it never protruded from the bell-aperture, and no peduncle was formed.

4) *Development of Tentacles and Statocysts*

The development of tentacles was independently examined on well-developed ones and on total ones including marginal warts without tentacles or those with short insufficiently developed tentacles. The increase of the number of the well-developed tentacles in Cla is as follows: The newly liberated medusa possesses 4 perradial tentacles, and this number does not change within 7 days after liberation. Then, their number increases one by one as medusa grows. About one month after liberation the development stops and the number attains 20 or more, which is about

6 times as many as the number of newly liberated medusa (Fig. 6, Te). The increase of the number of the total tentacles in Cla is as follows: The newly liberated medusa possesses 8 total tentacles, and this number does not change within 3 days after liberation. Then the increase began, namely the formation of the new marginal warts occurs and the formerly produced marginal warts develop into the well-developed tentacles. About one month after liberation, the formation of marginal warts stops and the number of the total tentacles attains about 30, nearly 4 times as many as the number of the newly liberated medusa (Fig. 6, Tte). From the 9th day to the time of degeneration of medusa, the

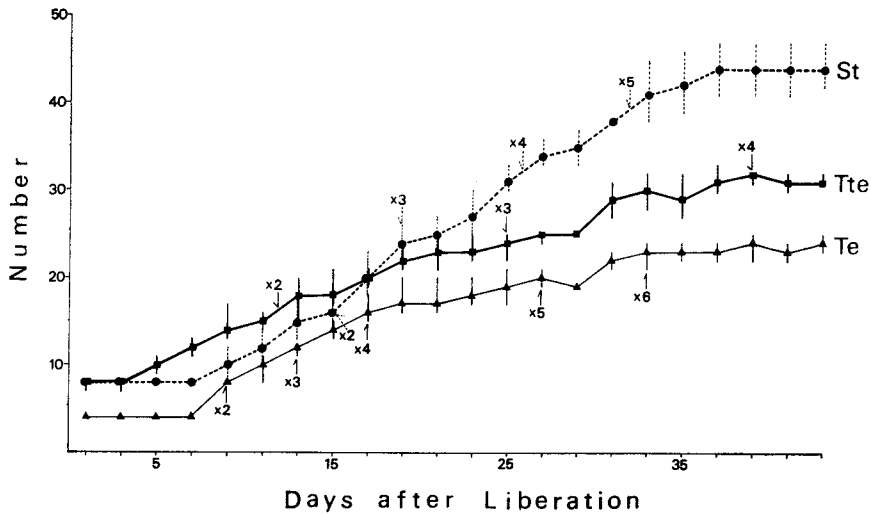

Fig. 6. Successive change of the number of well-developed tentacles (Te), of the total number of well-developed tentacles plus marginal warts (Tte), and of the number of statocysts (St) in the development of medusa (Cla). Numerals with arrows indicate ratios of the number to that of the newly liberated medusa.

growth curve of the number of the well-developed tentacles is parallel with that of the total ones. It indicates that the successive formation of marginal warts and the development of marginal warts into well-developed tentacles occur constantly for a month, though all the marginal warts are unable to develop into the well-developed tentacles when the medusa attains mature.

The increase of the number of the statocysts in Cla is as follows (Fig. 6, St): The newly liberated medusa possesses 8 statocysts. Within 7 days after liberation, this number does not change and the growth curve of the number of statocysts in this period is parallel with that of the well-developed tentacles. Then the statocysts are produced rapidly one after another. On the 11th day after liberation, the number of statocysts began to overlap with that of the total tentacles, completely

overlapped on the 17th day, and surpassed it on and after the 23rd day. About one month after liberation the formation stops, attaining about 45 in number, 5 or more times as many as the number of the newly liberated medusa.

Some important taxonomic features of medusa are examined for 6 mature medusae of 54 days old of Cla and their results are shown in Tables 7-10. The maximum number of the well-developed tentacles in a medusa and that of the total tentacles is 28 and 30 respectively (Table 7), while the latter attained 33 between

Table 7. Number of well-developed tentacles (+), total tentacles (×), and of statocysts (○) in a quadrant of a medusa (6 specimens 54 days old).

Cla	4	5	6	7	8	9	10	11	12	13	14	15	Te	Tte	St
1		++	**	××○			○	○	○				22	26	40
2		+*	*		*×	○	○		○			○	24	27	46
3	+	+	+*	×	××	○	○○				○		21	29	43
4			++	××	**	○		○		○			28	30	45
5	+	+	+*	×	*×	○	○○		○				21	29	41
6		++	×	+	*××			○	○○	○	○		25	30	49

Table 8. Number of statocysts in every interbulbar space (6 specimens 54 days old).

Cla	0	1	2	3	Tte
1	1	11	13	1	26
2	0	11	13	3	27
3	0	17	10	2	29
4	0	16	13	1	30
5	0	18	10	1	29
6	0	14	13	3	30
Total	1	87	72	11	171

Table 9. Number of statoliths in a statocyst (6 specimens 54 days old).

Cla	1	2	3	4	St	Stl
1	37	2	0	1	40	45
2	38	6	1	1	46	57
3	40	1	2	0	43	48
4	38	5	2	0	45	54
5	37	4	0	0	41	45
6	43	6	0	0	49	55
Total	233	24	5	1	264	304

Table 10. Relative abundance of well-developed tentacles, total tentacles, and statocysts in different developmental stages of medusa (represented by %).

Age (days)	No. m	Tte>St	Tte=St	Tte<St	Te=St	Te<St
1	20		95.0	5.0		100
7	18	100			33.3	66.7
14	18	77.8	5.6	16.7	11.1	88.9
21	15	40.0	13.3	46.7		100
28	15	6.7	13.3	80.0		100
35	18	11.1	5.6	83.3		100
42	19	5.3		94.7		100
63	5			100		100
D	8		12.5	87.5	12.5	87.5

No. m: number of medusae examined
 D: degenerating (72-105 days old)

Table 11. Relative abundance of number of well-developed tentacles, of total tentacles, and of statocysts in various developmental stages of medusa (Cle), represented by individual number of medusa.

Age(days)	No.																																				No. of medusae examined																																																																																																																																																																																																																																																																																																																																																																																																																																																																																																																																																																																																																																																																																																																																																																																																																																																																																												
	4	5	6	7	8	9	13	14	15	16	17	18	19	20	21	22	23	24	25	26	27	28	29	30	31	32	33	34	35	36	37	38	39	40																																																																																																																																																																																																																																																																																																																																																																																																																																																																																																																																																																																																																																																																																																																																																																																																																																																																																															
1	20																																				20																																																																																																																																																																																																																																																																																																																																																																																																																																																																																																																																																																																																																																																																																																																																																																																																																																																																																												
7	3	0	6	3	6																																						17	1																														14							1	1	5	10	1																																						2	0	0	3	3	2	3	1	1	0	0	3																											6	2	4	2	0	2	1	0	1																		21										10	3	2																																																																																																								28																																																																																																																					35																																																																																																																							42																																																																																																																								63																																																																																																																								D																																																																																																																						
						17	1																														14							1	1	5	10	1																																						2	0	0	3	3	2	3	1	1	0	0	3																											6	2	4	2	0	2	1	0	1																		21										10	3	2																																																																																																								28																																																																																																																					35																																																																																																																							42																																																																																																																								63																																																																																																																								D																																																																																																																																																											
14							1	1	5	10	1																																						2	0	0	3	3	2	3	1	1	0	0	3																											6	2	4	2	0	2	1	0	1																		21										10	3	2																																																																																																								28																																																																																																																					35																																																																																																																							42																																																																																																																								63																																																																																																																								D																																																																																																																																																																																																
												2	0	0	3	3	2	3	1	1	0	0	3																											6	2	4	2	0	2	1	0	1																		21										10	3	2																																																																																																								28																																																																																																																					35																																																																																																																							42																																																																																																																								63																																																																																																																								D																																																																																																																																																																																																																																					
												6	2	4	2	0	2	1	0	1																		21										10	3	2																																																																																																								28																																																																																																																					35																																																																																																																							42																																																																																																																								63																																																																																																																								D																																																																																																																																																																																																																																																																											
21										10	3	2																																																																																																								28																																																																																																																					35																																																																																																																							42																																																																																																																								63																																																																																																																								D																																																																																																																																																																																																																																																																																																																	
																																																																														28																																																																																																																					35																																																																																																																							42																																																																																																																								63																																																																																																																								D																																																																																																																																																																																																																																																																																																																																																							
																																							28																																																																																																																					35																																																																																																																							42																																																																																																																								63																																																																																																																								D																																																																																																																																																																																																																																																																																																																																																																																														
28																																																																																																																					35																																																																																																																							42																																																																																																																								63																																																																																																																								D																																																																																																																																																																																																																																																																																																																																																																																																																																					
																																																																														35																																																																																																																							42																																																																																																																								63																																																																																																																								D																																																																																																																																																																																																																																																																																																																																																																																																																																																																												
																																							35																																																																																																																							42																																																																																																																								63																																																																																																																								D																																																																																																																																																																																																																																																																																																																																																																																																																																																																																																																			
35																																																																																																																							42																																																																																																																								63																																																																																																																								D																																																																																																																																																																																																																																																																																																																																																																																																																																																																																																																																																										
																																																																																42																																																																																																																								63																																																																																																																								D																																																																																																																																																																																																																																																																																																																																																																																																																																																																																																																																																																																																	
																																								42																																																																																																																								63																																																																																																																								D																																																																																																																																																																																																																																																																																																																																																																																																																																																																																																																																																																																																																																									
42																																																																																																																								63																																																																																																																								D																																																																																																																																																																																																																																																																																																																																																																																																																																																																																																																																																																																																																																																																																	
																																																																																63																																																																																																																								D																																																																																																																																																																																																																																																																																																																																																																																																																																																																																																																																																																																																																																																																																																																									
																																								63																																																																																																																								D																																																																																																																																																																																																																																																																																																																																																																																																																																																																																																																																																																																																																																																																																																																																																																	
63																																																																																																																								D																																																																																																																																																																																																																																																																																																																																																																																																																																																																																																																																																																																																																																																																																																																																																																																																									
																																																																																D																																																																																																																																																																																																																																																																																																																																																																																																																																																																																																																																																																																																																																																																																																																																																																																																																																																	
																																								D																																																																																																																																																																																																																																																																																																																																																																																																																																																																																																																																																																																																																																																																																																																																																																																																																																																																																									
D																																																																																																																																																																																																																																																																																																																																																																																																																																																																																																																																																																																																																																																																																																																																																																																																																																																																																																																																	

D: degenerating (72-105 days old)

the 33rd to 43rd day after liberation. It was observed that Te, Tte, and St in each quadrant of a medusa are not always equal in these specimens (Table 7). In order to presume the average or general condition of Tte, Te, and St in different developmental stages of medusa, noticing the fact that the umbrellar margin was divided into 4 quadrants by the radial canals, the increase of Tte, Te, and St in a quadrant was examined in detail in Cle, and the result is shown in Fig. 7 (cf. Table 11). Most of Tte in a quadrant is 4–7 in 14–21 days old immature medusa, and 6–8 in the mature medusa. Then the formation of marginal warts progresses further to take the condition that 8 Tte are present in all the quadrants (Fig. 7, A). Most of Te in a quadrant is 4 in 14–21 days old immature medusa, and 4–5 in the mature medusa. The development of marginal warts into the well-developed tentacles seems to progress further until the medusa is degenerated, while all of them are always unable to develop completely (Fig. 7, B) as was observed in Cla. As the maximum number of the total or well-developed tentacles in a quadrant is 8 in the grown medusa from matured to degenerated ones, up to 32 total or well-developed tentacles could be produced in a medusa among the specimens from Oshoro.

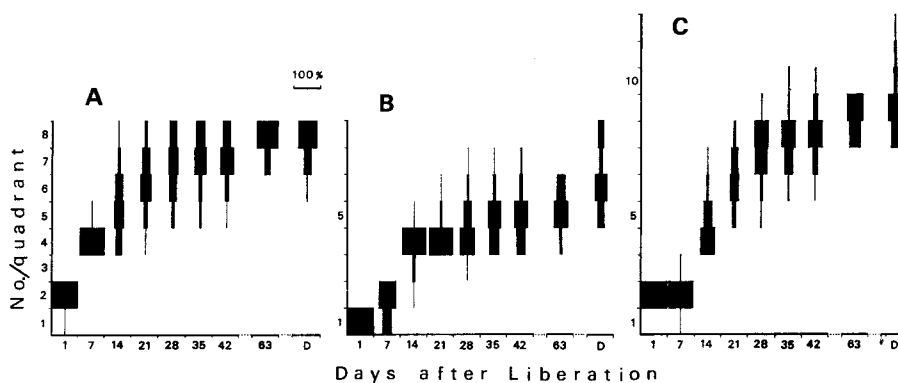

Fig. 7. Relative abundance (shown in breadth of rectangles) of the total number of well-developed tentacles plus marginal warts in a quadrant (A), of well-developed tentacles in a quadrant (B), and of the number of statocysts in a quadrant (C) in various developmental stages of medusa (Cle). D: time of degeneration of medusa (72–105 days old).

On the other hand, most of St in a quadrant is 4–7 in 14–21 days old immature medusa, and 7–8 in the mature medusa. Then the formation of statocysts progresses further until the medusa degenerates when most of St in a quadrant is more than 8 and a wide variation range is still present and some of them attains 12 (Fig. 7, C).

The relationship among Te, Tte, and St in different developmental stages of a medusa is examined in detail in Cle (Table 10). As was observed in Cla, $Te < Tte$ is always present and $Te > St$ is never found in the whole developmental stages of

medusa of *Cle*. $Te < St = Tte$ is observed in the newly liberated medusa, $Te \leq St < Tte$ in the medusa 7 days old, $Te < St \leq Tte$ in the medusa 14 days old, $Te < St < Tte$ or $Te < Tte < St$ in the medusa 21 days old, and $Te < Tte < St$ in the mature medusa. It was observed that in one medusa 74 days old, Te , Tte , and St are all 32, and 8 well-developed tentacles and 8 statocysts are present in each quadrant, and it is destitute of marginal warts.

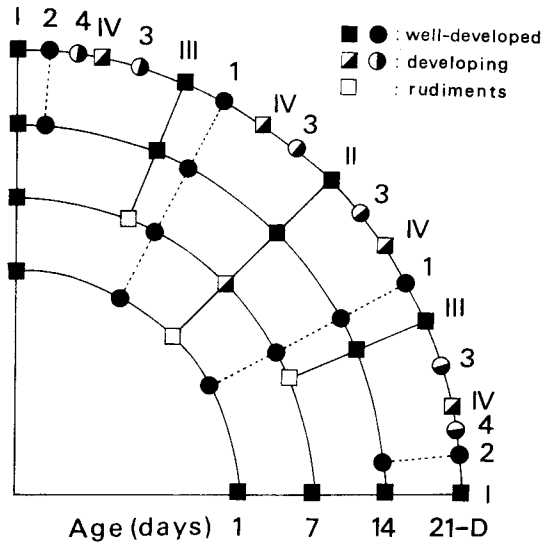

Fig. 8. Diagram showing the subsequent appearances of well-developed tentacles or marginal warts (\square : I-IV) and of statocysts (\circ : 1-4) in a quadrant, from oral side. D: degenerating medusa 72-105 days old.

The sequence of appearance of tentacles and statocysts was observed in detail in *Cle* and are shown in Fig. 8. Their sequence is regular, namely they are produced symmetrically on the sides of interradius. The first set of marginal tentacles is of 4 perradial ones (Fig. 8, I) and the second one is of 4 interradial ones (Fig. 8, II). The third set is of 8 adradial tentacles (Fig. 8, III) which are produced at a side of the first set of statocysts (Fig. 8, 1). The last fourth set of marginal tentacles is of 16 adradial tentacles but they do not appear at once. On the other hand, the first set of statocysts is of 8 adradial ones which do not appear precisely on the adradia but coming slightly nearer to the interradia. The second set is of 8 adradial ones (Fig. 8, 2) which are produced at the sides of perradial. The third set is of 16 adradial ones (Fig. 8, 3) which are not produced at once. The fourth set of statocysts is of 8 or more adradial ones (Fig. 8, 4), most of which are produced at the sides of perradius near the second set of statocysts.

The number of statocysts in every interbulbar space, which is an important characteristic of medusa, was examined in 6 mature 54 days old medusae of *Cla*

Table 12. Number of statocysts in every interbulbar space in different developmental stages of medusa (represented by %).

Age (days)	No. m	Tte	0	1	2	3
1	20	159		99.4	0.6	
7	18	289	49.8	50.2		
14	18	385	16.9	81.0	2.1	
21	15	370	10.8	81.1	10.8	
28	15	410	2.4	87.3	10.2	
35	18	507	1.8	87.4	10.8	
42	19	546	0.2	88.3	11.5	
63	5	156		89.7	10.3	
D	8	245		81.2	18.4	0.4

No. m: number of medusae examined
 D: degenerating (72-105 days old)

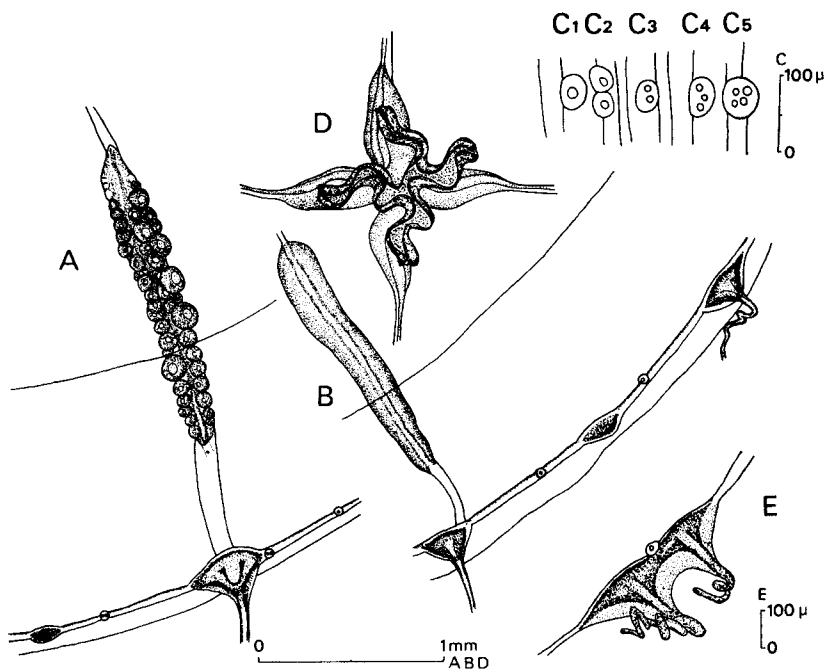

Fig. 9. Various body portions of medusa, oral view. A: a part of umbrellar margin and a gonad of female medusa 35 days old (C2); B: a part of umbrellar margin and a gonad of male medusa 42 days old (Cle); C: Several statocysts (Cle), C₁: a statocyst containing one statolith, C₂: two statocysts adjoining together, C₃-C₅: statocysts containing two to four statoliths; E: two tentacles adjoining together with a statocyst between them (Cle).

(Table 8). In these specimens usually one or two statocysts, rarely 3 or none, are present in this space. It was occasionally observed that two statocysts were adjoined each other (see Fig. 9, C₂). The increase of the number of the statocysts in this space was examined in different developmental stages of medusa in Cle (Table 12). One statocyst is present in this space in the newly liberated medusa. In the medusa 7 days old, this number is one or none, and no statocyst is present in some of this space in immature medusa of 14–21 days old, owing to the isochronous development or different growth rate in successive appearance of the tentacles and the statocysts as mentioned above. In the mature medusa, one statocyst is mostly present in this space, while 2 statocysts are sometimes present in the space at the sides of perradii (see Fig. 8) and are rarely present in the other spaces. Three statocysts are seldom present in the space. Statocyst is not always equidistant in this space when it is single (Fig. 9, A and B). It was observed that the presence of two statocysts in this space in the mature medusa of Cla was more frequent than that of Cle (see Tables 8 and 12).

Table 13. Number of statoliths in a statocyst in different developmental stages of medusa (represented by %).

Age (days)	No. of medusae examined	No. of statocysts examined	0	1	2	3	4
1	20	160	0.6	98.1	1.3		
7	18	143	1.4	97.9	0.7		
14	18	328		86.9	9.5	3.7	
21	15	380		76.1	16.8	5.0	2.1
28	15	442		79.0	16.1	4.3	0.7
35	18	553		87.2	11.8	1.1	
42	19	608	3.0	86.2	10.0	0.8	
63	5	172		83.1	15.1	1.7	
D	8	292		81.5	16.4	1.7	0.3

D: degenerating (72–105 days old)

The number of statoliths in a statocyst was examined in 6 specimens of Cla (Table 9), furthermore the number of statoliths in a statocyst in different developmental stages of medusa was examined in detail in Cle (Table 13). Most of the statocysts contain one statolith in the whole developmental stages of medusa, while two statoliths are sometimes contained in a statocyst and rarely 4, 3, and none (Fig. 9, C₁–C₅).

5) Development of Gonads

The rudiments of gonads are found already in the newly liberated medusa. Then the tiny immature gonads grow larger and stretch out. As the medusa grows, the gonads become lean and long. About one month after liberation the growth of gonads stops (Table 6, GL and GW; Fig. 10, A–G) and the gonads are completely

matured. The matured gonads are usually elongated and the surface is smooth, while their size is variable and non-elongated gonads were found. The gonads are present on the distal half of the radial canal, but not reaching the ring canal (Plate VII, 5, 6). Occasionally there was a hole on the radial canal near the distal end of gonads (Fig. 9, A; Fig. 10, F₁), and the part of radial canal distal to gonads is wider than that proximal to them (Fig. 9, A and B; Fig. 10, F₂).

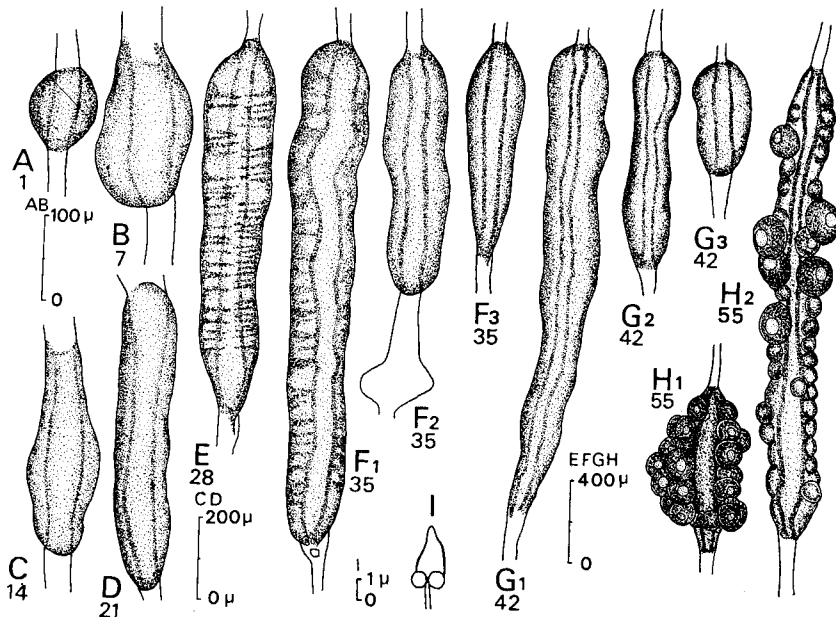

Fig. 10. A-G: development of male gonads (Cle); H₁-H₂: female gonads of medusa 55 days old (see Table 19, No. 1, 2); I: spermatozoa; F₁, G₁, and H₂: elongate type of gonads, F₂-F₃, G₂-G₃, and H₁: non-elongate type of gonads. Numerals under the capitals indicate the age of medusa in days.

6) Concluding Remarks on Metamorphosis of Medusa

In addition to the rearing of medusae of Cla and Cle, a number of the youngest medusae of Clc and Clh were also reared. It was observed that the early developmental change of medusa of Clc, which was examined every other day, was nearly the same as that of Cla. Out of a large number of the youngest medusae of Clh, 35 ones were picked up at random and their various body portions were measured, and 10 of them were reared until they attained mature under different culture conditions from that of Cla and Cle; they were kept under nearly continuous illumination for more than a month, and the sea water and the container were changed about once a week. The measurements of 35 youngest

medusae and of 10 female mature ones 42 days old of Clh are (in mm):

Youngest medusa: $W=0.63-0.78-1.13$, $H=0.44-0.54-0.63$, $M=0.19-0.25-0.31$, $J=\text{up to } 0.06$, $Te=4$, $Tte=St=Stl=8(34)$ and $Tte=8$ $St=Stl=7(1)$

Mature medusa: $L=2.38-2.57-2.86$, $GL=0.32-0.40-0.48$, $M=0.48-0.62-0.63$, $S=0.32-0.38-0.48$, $J=0.95-1.06-1.11$, $W=6.35-7.06-7.94$, $H=3.33-3.76-4.13$, $Te=14-14.9-16$, $Tte=17-18.0-20$, $St=18-20.7-24$, $Stl=19-21.1-26$

The mature medusa of Clh is smaller than that of Cla and Cle, and Te , Tte , and St of Clh are fewer than those of the latter. Moreover, their gonads are small and oval, and 4 of the specimens possessed abnormal oral lips; one of which possessed a manubrium-like protrusion formed at the proximal portion of gonads, and 3 of which unusually possessed 2, 3, and 8 oral lips respectively.

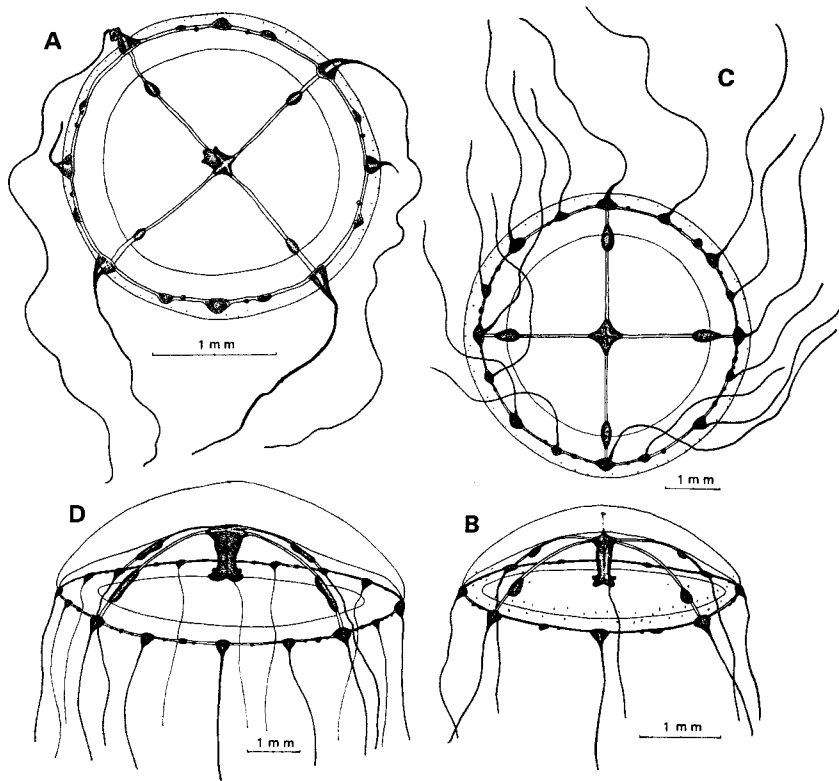

Fig. 11. A: a young medusa 7 days old with 4 well-developed tentacles; B: a young medusa 8 days old with 8 well-developed tentacles, exumbrellar nematocysts, umbilical canal, and depression of umbrellar apex; C: a young medusa 14 days old with 16 well-developed tentacles and a trace of depression on exumbrellar apex; D: a immature medusa 22 days old with 16 well-developed tentacles and a trace of depression on exumbrellar apex, (A-D: Cle). A, B, D: tentacles are considerably contracted.

As was described above, the metamorphosis of medusa, accompanying with enlargement of umbrellar size, complication of various organs, disappearance of characters for young medusa, and maturation of gonads, was completed about in one month after the medusa is liberated from the polyp (Fig. 11, A-D; Fig. 12). The growth of medusa is depicted as a sigmoid curve which is composed of lag-phase in 1-7 days after liberation, exponential-phase in 7-30 days, and stationary-phase in 30 days to about three months after liberation. The degeneration of medusa of *Cle* usually began in 70-80 days after liberation, while it began on the 105th day in one medusa. The life-span of medusa of this species is, therefore, within about three months. When the degeneration began, the oral lips were broken and some statocysts and marginal warts were obscure.

Seasonal Occurrence of Hydroid in Oshoro Bay

In Oshoro Bay, about 40 colonies of polyps were found from spring to autumn but not in winter, namely they were found from April to November except for the late summer (August) and early autumn (September). Most of the colonies appeared prominently and bore gonangia from late spring (May) to early summer (June), however, all the colonies found in this period did not always bear gonangia. The gonangia with distinct corrugations, which are one of the prominent characteristics of this species, are present in all these colonies attached to various substrata. It was observed that the polyp colonies were found on the floating *Sargassum* in autumn, the withering season of this alga.

On the other hand, by the horizontal and vertical hauls of tow-net, the occurrence of medusa in a year was studied. The medusa appeared from spring to autumn (May to September) in accord with the appearance of polyp. In these seasons a large number of newly liberated medusae were captured from late spring to early summer (May to June). After a month from the peak of appearance of the youngest medusa, the older and mature medusae appeared (from late July to early August). A marked rise of water temperature in May (see Motoda, 1971) is in accord with the abundant appearance of the present hydroid.

The morphology of newly liberated medusa captured in the sea coincided well with that of the medusa newly liberated in laboratory. It was noticed that the exumbrellar nematocysts are usually present as a horizontal band, though their number is variable and often fewer than that of youngest medusa liberated in laboratory. It was observed that one medusa possessed a remnant of polyp on its apex, the color of subumbrellar surface of 3 medusae was green, and some of the youngest medusae possessed 7 statocysts. In some medusae the size of some statocysts is smaller than the others. One abnormal medusa which possessed 5 radial canals, 10 total tentacles, 5 well-developed tentacles, 9 statocysts, and 7 statoliths was found. Some of the statocysts and the marginal warts of another medusa were present near the perradii as an exceptional case. The measurements of 74 youngest medusae ($T_e=4$, $T_t=8$, $St=8$) collected from May to July of 1977

are as follows:

$$W=0.63-0.96-1.38 \text{ mm, } H=0.36-0.64-0.94 \text{ mm, } Stl=3-7.5-9$$

Only a small number of the older and mature medusae were captured in this study. Their measurements of various body portions are shown in Table 14. The maximum umbrellar width attains 9.5 mm, and the maximum number of the well-developed tentacles, total tentacles, and of statocysts are 17, 22, and 26 respectively. These numbers are inclined to be fewer than those of the mature medusa reared in the laboratory, though the other morphology fairly coincides with each other. It is noteworthy that the gonads are oval in younger stage, but elongated in mature stage. They are present on distal parts of radial canals, and their color is green. A trematode parasitic on inside of umbrellar jelly was found in two older medusae (Table 14; Plate VII, 8).

Table 14. Measurements of various body portions of the older and mature medusae collected from Oshoro Bay (mm).

No.	L	GL	GW	M	S	J	W	H	Te	Tte	St	Stl	sex
1	1.30	0.30	0.20	0.40	0.50	0.50	3.20	2.50	12	20	16	16	♂
2*	3.33	0.63	0.44	0.95	0.63	0.79	6.35	2.38	11	19	20	20	♀
3	2.00	0.40	0.30	0.70	0.35	0.60	5.40	2.20	9	20	18	18	♂
4#	1.60	1.30	0.20	—	—	—	4.50	—	11	16	26	28	♂
5	2.38	0.79	0.32	0.95	0.48	0.63	6.67	2.06	12	19	16	17	♀
6*	1.59	0.40	0.19	0.63	0.32	0.48	4.92	1.75	8	20	17	17	♂
7	1.43	0.48	0.32	0.79	0.32	0.48	4.76	1.59	12	16	20	20	♂
8	2.38	0.95	0.48	—	—	0.87	6.83	3.49	17	22	25	26	♀
9	3.17	1.43	0.40	0.95	0.48	0.95	9.52	3.81	16	19	21	21	♂
10	1.50	0.30	0.20	0.70	—	0.50	4.80	1.50	10	20	12	12	♂
11	—	0.22	0.18	0.60	0.20	0.40	3.70	1.00	8	16	13	13	♀

*: parasitized by a trematode #: manubrium not present

Nos. 1-4, collected on 25-VII-'77; Nos. 5-11, collected on 2-VIII-'77

Morphological Variations of Medusae from Different Localities

The youngest medusae were also obtained from the polyps collected near Oshoro Bay (C2), from Akkeshi Bay (C3), and from Muroran (C4), and these were reared for about two months in an incubator at $12 \pm 2^\circ\text{C}$ in order to compare them with the medusae from Oshoro Bay (see Table 1). Some of the medusae of C2 were also reared at the room temperature (about 23°C) to know whether the morphological difference appeared under different water temperature or not. The metamorphosis of these medusae is also completed in about one month after liberation. The morphology of the newly liberated medusae from these three localities were examined and it was the same as that of the youngest medusa from Oshoro Bay (Table 15). On the other hand, the mature medusae from near Oshoro Bay reared in lower temperature were the same in the morphology as those of Oshoro Bay, while those from Akkeshi Bay and Muroran were somewhat different (Tables

Table 15. Measurements of various body portions of newly liberated medusae from localities other than Oshoro Bay (mm).

MA	C2	C3	C4
No. of medusae examined	10	6	6
M	0.19-0.20-0.22	0.19-0.22-0.25	0.14-0.18-0.20
S	0.09-0.11-0.13	0.13-0.14-0.19	0.08-0.09-0.09
J	0.01-0.03-0.05	0.03-0.04-0.05	0.02-0.04-0.05
W	0.50-0.61-0.72	0.79-0.84-0.88	0.56-0.62-0.69
H	0.31-0.44-0.53	0.56-0.56-0.56	0.41-0.49-0.56
Te	4-4-4	4-4-4	4-4-4
Tte	6-8-8	8-8-8	8-8-8
St	7-8-8	8-8-8	8-8-8
Stl	7-8-8	8-8-9	8-8-8

Table 16. Measurements of various body portions of reared mature medusa from localities other than Oshoro Bay (mm).

MA	C2*	C2	C3	C4
No. of medusae examined	8	11♀+4♂	7♂	6♀+2♀
Age (days)	35	35	42	35+28
L	1.75-2.28-3.02	1.59- 2.61- 3.49	2.54- 2.76- 2.86	2.54- 2.71- 3.02
GL	0.63-0.98-1.59	1.27- 1.65- 2.22	1.27- 1.68- 2.06	0.95- 1.25- 1.59
GW	0.13-0.15-0.16	0.32- 0.33- 0.48	0.24- 0.35- 0.48	0.24- 0.32- 0.35
M	0.48-0.56-0.63	0.79- 0.98- 1.11	0.63- 0.83- 0.95	0.56- 0.81- 0.95
S	0.44-0.50-0.63	0.48- 0.80- 0.95	0.79- 1.08- 1.27	0.71- 0.81- 0.87
J	0.79-0.94-1.03	0.95- 1.32- 1.59	1.27- 1.35- 1.43	1.03- 1.11- 1.27
W	5.71-7.78-9.68	6.51-10.05-12.06	9.84-10.62-11.59	9.52-10.10-10.48
H	3.02-3.36-3.65	3.02- 3.97- 4.76	3.97- 4.30- 4.76	2.86- 3.57- 4.13
Te	15-18-20	20-23-30	14-18-20	15-17-20
Tr	0-2-7	1- 6-10	9-15-20	3- 5- 7
Tte	15-20-25	25-28-32	28-33-36	20-22-24
St	27-34-51	34-39-48	37-47-54	26-29-32
Stl	29-37-54	31-47-64	40-69-80	29-32-40

*: reared at room temperature (ca. 23°C)

16, 17). Among these reared mature medusae from three different localities, their umbrellar size and the number of the well-developed tentacles are nearly equal one another, though the number of total tentacles, of statocysts, and of statoliths are the least in C4 and are the greatest in C3 (Table 16). It is noteworthy that 9-11 total tentacles were present in a quadrant of the mature medusae of C3 (Table 17). In all these mature medusae, both the number of statocysts in every interbulbar

Table 17. Number of well-developed tentacles, total tentacles, and of statocysts in a quadrant of mature medusa from other localities than Oshoro Bay (represented by %).

MA	Q	No.	2	3	4	5	6	7	8	9	10	11	12	13	14	15	
C2*	32	Te		3.1	62.5	28.1	6.3										
		Tte		3.1	37.5	37.5	12.5	9.4									
		St				3.1	18.8	18.8	28.1	3.1	3.1	0.0	12.5	12.5			
C2	60	Te			10.0	30.0	43.3	10.0	6.7								
		Tte					25.0	40.0	31.7	3.3							
		St						6.7	5.0	30.0	40.0	11.7	3.3	1.7	1.7		
C3	28	Te	3.6	3.6	50.0	32.1	10.7										
		Tte					7.1	17.9	39.3	25.0	7.1	3.6					
		St							3.6	7.1	21.4	14.3	14.3	25.0	10.7	3.6	
C4	32	Te		3.1	65.6	28.1	3.1										
		Tte			6.3	31.3	62.3										
		St				3.1	25.0	34.4	31.3	6.3							

Q: number of quadrants examined *: reared at room temperature (ca. 23°C)

Table 18. Number of statocysts in every interbulbar space, and number of statoliths in a statocyst in mature medusa from other localities than Oshoro Bay (represented by %).

	MA	Total number counted	0	1	2	3	4
St	C2*	157	1.3	36.3	49.0	13.4	
	C2	428	0.2	64.7	33.9	1.2	
	C3	229		59.4	38.9	1.3	0.4
	C4	154	1.1	70.2	28.1	0.6	
Stl	C2*	274	0.4	89.4	9.9	0.4	
	C2	582	3.4	71.6	22.5	2.4	
	C3	327	2.1	56.6	33.6	6.7	0.9
	C4	228	0.4	87.7	11.4	0.4	

*: reared at room temperature (ca. 23°C)

space and that of statoliths in a statocysts is one or two (Table 18).

The morphological difference was observed between the mature medusae reared under different water temperatures. Compared with the morphology of mature medusae reared at lower temperature, the ones reared at higher temperature were smaller in the various body portions such as W, H, M, S, J, GL, and GW; and the number of well-developed tentacles and of total tentacles were fewer (Table 16). Moreover, abnormal development was observed in the latter medusae, namely the fifth radial canal was shortly extended from the stomach and the mouth was

divided into 5 or 6 oral lips in 53 days old stage (Plate VII, 9).

Description of Mature Medusa

The general morphology of mature medusa from Hokkaido (Fig. 12; Plate VII, 5-7) is as follows: The umbrella is exceedingly wider than high, watch-glass shaped. The umbrella is about 10 mm (up to 12 mm) in width and about 4 mm (up to 5.6 mm) in height. The ratio of the umbrellar height to the umbrellar width is 1:2-4. The jelly is mostly thick at the apical portion of the umbrella,

Fig. 12. A mature medusa 42 days old with 19 well-developed tentacles (Cle, ♂).

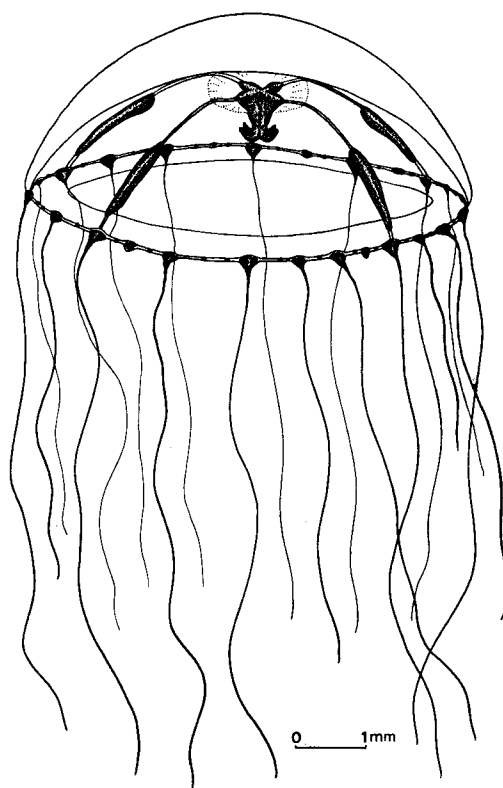

about 1.3 mm (up to 1.6 mm) in thickness, and becomes thinner toward the umbrellar margin. There are no exumbrellar nematocysts, umbilical canals, and depression of umbrella. The manubrium is funnel-shaped and fairly short (about 0.8 mm, up to 1.1 mm in length). The stomach is cross-shaped and small (about 1.0 mm, up to 1.3 mm in breadth). Four oral lips are once folded and slightly recurved. Nematocysts of one kind are present on oral lips. There are 4 straight radial canals, and the distal part of them distal to gonads is sometimes

wider than that proximal to gonads. The gonads are usually elongated, but sometimes non-elongated, and are continuous over the lower wall of radial canals without a median furrow. They are situated on distal half of radial canals, but not reaching the ring canal. There are no distinct peduncle, adaxial papillae, nor excretory pores. There are 14–32 well-developed marginal tentacles with distinct basal bulbs and some marginal warts without tentacles. The maximum total number of the well-developed tentacles plus marginal warts is generally 32, but may attain 36. Nematocysts of two kinds are present on tentacles. The number of statocysts in a medusa is more than that of the total tentacles. Their number is variable and 26–54. One or two statocysts are usually present in every interbulbar space, taking irregular distances. A statocyst usually contains one or two spherical statoliths, but rarely 4, 3, and none. The velum is narrow (about 1.2 mm, up to 1.7 mm in breadth), and the umbrellar aperture is wide. The umbrella is transparent, while the stomach, gonads, and tentacular bulbs or warts are orange in the reared mature medusa. Their color is possibly due to the food (*Artemia*). The gonads of medusa captured in the sea is green in color.

Description of Early Embryonic Stages

Eight youngest medusae were found among the plankton samples of Oshoro Bay, and were kept until their attaining mature for about two months. The mature medusae obtained in such the way were the same in their morphology as the ones reared from the polyp collected from Oshoro Bay (Table 19). Fortunately both sexes were found among them, so the fertilization took place in the container.

Table 19. Measurements of various body portions of reared mature medusa 42 days after capture (mm).

No.	L	GL	GW	M	S	J	W	H	V	Te	Tte	St	Stl	Sex
1	2.86	2.38	0.32	1.27	0.63	1.27	11.59	3.97	1.57	17	23	37	47	♀
2	3.33	0.79	0.32	0.95	0.63	1.11	10.00	3.17	1.59	20	27	30	61	♀
3	2.38	2.06	0.32	0.63	0.79	1.27	10.32	3.17	1.27	22	26	28	29	♂
4	4.13	1.11	0.20	1.11	0.79	0.95	12.38	3.97	1.27	19	33	33	31	♂
5	3.02	0.79	0.20	0.87	0.48	1.03	9.52	3.97	—	16	25	30	31	♂
6	3.17	1.03	0.31	0.95	0.63	0.79	10.48	3.17	1.43	18	30	29	29	♀
7	2.86	0.63	0.22	0.79	0.40	0.87	8.73	3.17	1.11	15	23	25	25	♂
8	2.38	1.43	0.30	0.95	0.79	1.11	10.32	4.29	—	17	28	29	32	♂

Nos. 1–3: collected on 11-V-'76, Nos. 4–7: collected on 26-V-'77, No. 8: collected on 23-V-'77

A number of eggs were spawn from some of these medusae and falled onto the bottom-surface of the container. The diameter of the fertilized eggs discharged from the mature medusae (Nos. 1–3) 46 days after capture and that of the eggs discharged from the mature medusae (Nos. 4 and 6) 49 days after capture is 163–170–187 μ (21) and 148–166–176 μ (9) respectively. Furthermore the diameter of the fertilized eggs discharged from several mature medusae of C2 is 163–

173–187 μ (10), while smaller eggs which are probably unfertilized ones were found and their diameter is 117–140–152 μ (25). The reared mature medusae from Muroran were female and they discharged the eggs. The diameter of the unfertilized eggs is 140–156–163 μ (14) and is as nearly equal as those from Oshoro. The spermatozoa (Fig. 10. I) were observed (Cle) and the length from head to middle piece was 3.3–3.3–3.5 μ (10).

The cleavage of eggs is of radial type. The coeloblastula is not regular elliptical oval in shape showing more or less wry surface and variable size. The gastrula is formed by a unipolar ingression. Fertilized eggs develop into planulae within several days under laboratory conditions. The planula rolls on by the movements of the epidermal cilia. The direction of rotation of planula is right-handed when the planula is observed from the direction of its proceeding. Three

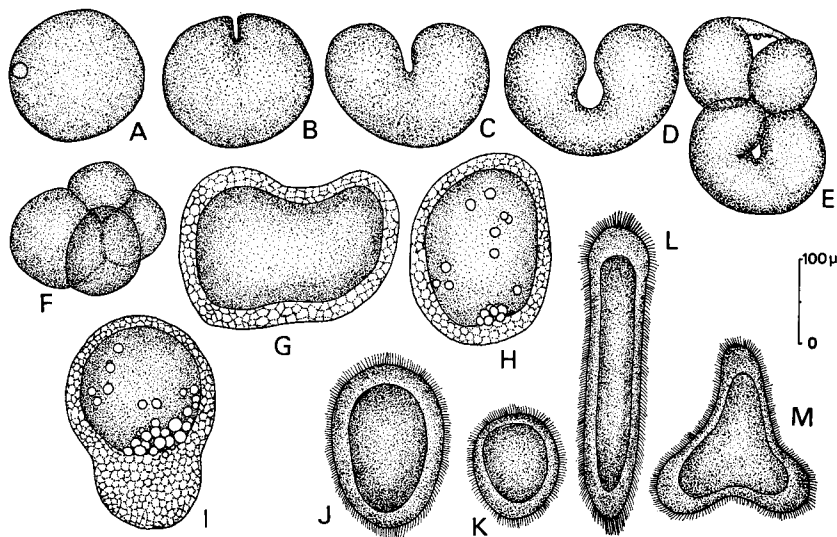

Fig. 13. Early embryonic stages (C2). A: an egg; B-D: first cleavage; E-F: second cleavage; G: blastula; H-I: unipolar ingression; J-M: planulae of three types.

types of planula, the oval one, the elongated one, and the trifurcated one were found (Fig. 13, J-M). The size (length \times maximum width) of these three types of planula in C2 under the well-relaxed conditions is: 82–156–210 \times 82–100–140 μ (9), 222–310–373 \times 70–82–105 μ (13), and 117–151–175 \times 105–121–140 μ (3) respectively. The size of two elongated planulae from the mature medusae of Nos. 1–3 and other two elongated planulae from that of Nos. 4 and 6 is 280 \times 82 μ , 257 \times 93 μ and 248 \times 72 μ , 224 \times 112 μ in well-relaxed conditions respectively. The planula swam for about one week, while their attachment to the container surface was not observed in the present study.

Description of Nematocysts

The examinations on the nematocysts of the present hydroid were made with living materials in their different life stages and on their different body portions under the phase-contrast microscope. The results are shown in Tables 20-23 and Fig. 14.

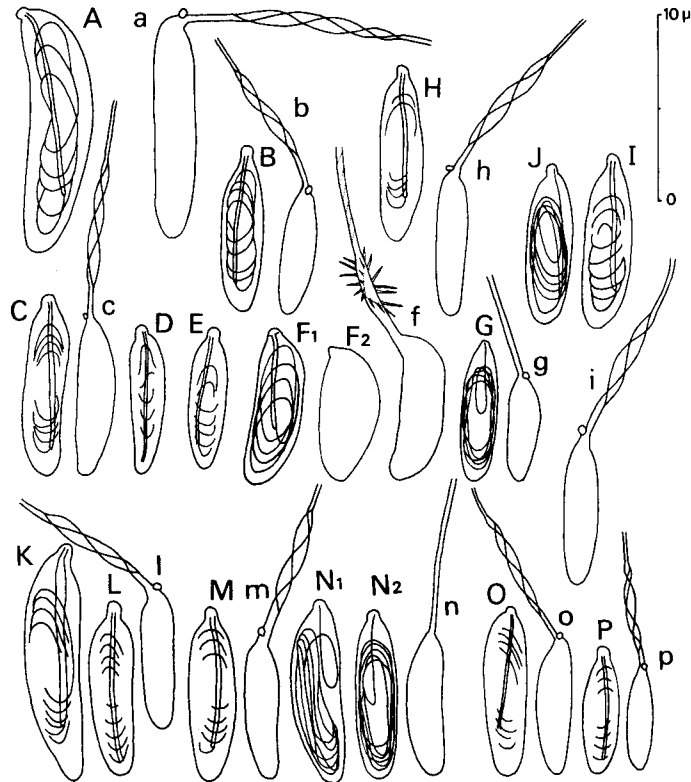

Fig. 14. Nematocysts of various life stages of the present hydroid. Capital letters signify the undischarged state of nematocysts and small ones signify the discharged state of them. A(a)-B(b): in polyp (Clc); C(c)-G(g): in newly liberated medusa (Clf); H(h)-J: in medusa 22 days old (Cle); K-N(n): in mature medusa 42 days old (Cle); O(o)-P(p): in planula; A(a)-F(f), H(h)-I, K-M(m), and O(o)-P(p): microbasic mastigophores; G(g), J, and N(n): atrichous isorhizes. (F₂: butt and thread abridged)

One kind of nematocysts, microbasic mastigophores, is present on both tentacles and the hypostome of polyp (Table 20). The nematocysts on hypostome (Fig. 14, A-a) are larger and slender than those on tentacles (Fig. 14, B-b), moreover they are the largest ones in all the nematocysts found in the present hydroid. Several portions of polyp colony were cut off and from which all the hydranths

with the upper part of pedicels were taken away. After new hydranths were produced on them, the examinations of nematocysts were also made in the regenerated hydranths. The constitution and size of them is not different from the above description. This simple observation seems to indicate that these two types of nematocysts, especially larger ones on hypostome, are present undoubtedly.

Two kinds of nematocysts, microbasic mastigophores and atrichous isorhizes, are present in medusa (Tables 21-22). This constitution of nematocysts is different from that of polyp. In the newly liberated medusa, these two kinds of nematocysts, are present on tentacles; and only one kind of nematocysts, microbasic mastigophores, is present on both oral lips (Fig. 14, D) and on the exumbrella. It is noteworthy that most of the exumbrellar nematocysts (Fig. 14, C-c) were present on the distal half of the exumbrella as a horizontal band as described above. There were 200 exumbrellar nematocysts in one medusa of Clh. The microbasic mastigophores on tentacles are of two types, one of which exclusively occurs on the nematocyst cluster (Fig. 4, D; Fig. 14, F-f), but they are also present sparsely on the other parts of tentacles and their number is very few (Table 23). And they are stumper than the other type of microbasic mastigophores (Fig. 14, E), and the spines could be observed clearly on their butt. There were 2 to 8 such stumpy type of nematocysts in the nematocyst clusters (see Table 22). The slender type of microbasic mastigophores on tentacles are more in number than atrichous isorhizes (Fig. 14, G-g). Certain difficulties are found to distinguish the slender type of microbasic mastigophores from atrichous isorhizes. The distinction between them is apparent when they are discharged, however, under the undischarged state it is quite difficult because of their similarity in size and structure. Such the perplexity is solved by taking notice of the equipment of the butt, the mode of coiling of the thread, and the subtle difference of the shape of capsules of the nematocysts. It is noticed that in the youngest medusa the exumbrellar nematocysts are larger than the others, and their shape of capsules is slightly different from the others.

Two kinds of nematocysts, microbasic mastigophores (Fig. 14, I and L-1) and atrichous isorhizes (Fig. 14, J and N-n), are present on tentacles; and one kind of nematocysts, microbasic mastigophores (Fig. 14, H-h and M-m), is present on oral lips in the older and mature medusa. All these nematocysts are larger than those of the newly liberated medusae. It was observed that the larger and older the medusa grows, the larger the nematocysts are. The exumbrellar nematocysts disappear within three weeks after liberation. A larger type of microbasic mastigophores, which is similar to those found on the hypostome of polyp, is present on tentacles of mature medusa (Fig. 14, K) in a considerably small number. The measurements of these nematocysts in the mature medusa 43 days old of Cle are $11.4-12.3 \times 2.8-2.9 \mu(3)$. It is noteworthy that in the medusa of the present hydroid the constitution of nematocysts on tentacles is different from that of oral lips and of exumbrella.

Nematocysts were examined for the planulae obtained from some reared

Table 20. Measurements of nematocysts of polyp (μ).

MA	Microbasic mastigophores on tentacle				Microbasic mastigophores on mouth			
Clc	7.6-8.1-8.6×1.9-2.0-2.0 ¹⁾	4.0 ²⁾	2 ³⁾	30 ⁴⁾	12.1-13.3-14.4×1.9-2.7-2.8	4.9	2	30
Cle	7.3-7.6-7.9×1.9-2.0-2.0	3.8	3	30	12.1-13.0-14.1×2.6-3.0-3.7	4.3	4	30
C2	6.5-7.2-7.7×1.7-1.9-2.0	3.7	2	20	10.7-12.1-12.8×2.7-2.8-3.0	4.3	2	20
C3	6.5-7.2-7.6×1.9-2.0-2.1	3.5	4	30	10.7-11.9-13.0×2.8-2.9-3.3	4.1	7	30
C4	6.7-6.9-7.4×1.9-1.9-2.0	3.7	3	20	11.3-12.2-13.2×2.8-2.8-3.2	4.3	3	20

1): length × width of undischarged capsules 2): mean L/W value

3): number of zooids examined

4): number of nematocysts examined

Table 21. Measurements of nematocysts of newly liberated medusa (μ).

MA	Microbasic mastigophores on distal end of tentacle				Microbasic mastigophores on tentacle			
Cl _a	6.3-7.2-8.4×2.0-2.5-2.8 ¹⁾	2.8 ²⁾	3 ³⁾	30 ⁴⁾	—	—	—	—
Cl _h	7.2-7.7-8.4×2.4-2.7-3.0	2.9	2	20	6.8-7.5-8.0×1.8-1.9-2.2	3.9	2	20
Cl _f	6.7-7.8-8.8×2.5-2.8-3.3	2.8	4	30	7.4-7.8-8.4×1.9-1.9-2.1	4.0	2	30
C2	7.0-7.7-8.4×2.1-2.4-2.8	3.2	2	20	7.0-7.4-7.9×1.9-1.9-2.0	3.9	2	20
C3	6.5-7.0-7.6×2.1-2.5-2.8	2.8	3	10	6.5-6.7-7.3×1.9-1.9-2.0	3.6	3	20
C4	7.3-7.5-7.9×2.1-2.4-2.6	3.2	2	20	6.5-6.9-7.3×1.9-1.9-1.9	3.7	2	20

MA	Atrichous isorhizes on tentacle				Microbasic mastigophores on exumbrella			
Cl _a	—	—	—	—	7.4-8.3-9.1×1.9-2.0-2.3	4.1	3	30
Cl _h	5.6-6.3-7.2×1.8-1.9-2.2	3.3	2	20	8.4-9.2-10.0×2.0-2.4-2.6	3.8	2	20
Cl _f	6.3-7.2-7.9×1.8-1.9-2.0	3.8	2	30	8.6-9.4-10.7×2.0-2.4-2.8	3.9	3	30
C2	5.6-6.1-7.3×1.7-1.9-2.1	3.2	2	20	7.7-9.0-10.2×2.0-2.2-2.6	4.1	2	20
C3	4.7-5.1-5.8×1.7-1.9-2.0	2.8	3	20	7.4-8.4-9.3×2.3-2.5-2.6	3.4	3	20
C4	5.7-6.2-7.4×1.7-1.8-2.0	3.4	2	20	7.9-8.7-9.5×2.0-2.3-2.6	3.8	2	20

MA	Microbasic mastigophores on oral lip			
Cl _a	6.5-7.1-7.6×1.7-1.8-2.0	3.9	2	30
Cl _h	7.2-7.9-8.4×1.8-2.1-2.4	3.7	1	10
Cl _f	6.5-7.1-7.6×1.7-1.8-2.0	4.2	3	30
C2	7.4-8.0-8.4×1.9-1.9-2.0	4.3	2	20
C3	6.5-7.0-7.9×1.9-1.9-2.0	3.6	3	18
C4	6.7-7.3-7.9×1.9-1.9-2.0	3.8	1	15

1)-4): see Table 19

mature medusae (Nos. 1-3 in Table 19). There is one kind of nematocysts, microbasic mastigophores, on the whole body of planulae, but are of two types. The constitution of nematocysts in planula is the same as that of polyp, but is different from that of medusa. The measurements of nematocysts in planula are

Table 22. Measurements of nematocysts of reared older and mature medusa (μ).

MA	age (days)	Microbasic mastigophores on tentacle				Atrichous isorhizes on tentacle				
C1g*	22	8.4-8.6- 9.1×1.9-2.0-2.2 ¹⁾			4.2 ²⁾	2 ³⁾	20 ⁴⁾	7.6-8.2-8.8×1.9-2.1-2.3 3.9 2 20		
C2**	35	8.2-8.6- 9.1×2.0-2.1-2.2			4.2	2	20	7.3-7.7-8.4×1.9-2.0-2.0 3.9 2 20		
C2	36	8.8-9.2- 9.5×2.1-2.3-2.6			3.9	2	20	7.9-8.5-9.1×2.2-2.4-2.6 3.5 2 20		
C1g	43	8.4-9.1- 9.5×1.9-2.1-2.4			4.3	2	30	7.3-8.5-9.4×2.0-2.3-2.8 3.7 2 30		
C3	38	7.9-8.5- 9.5×2.0-2.1-2.3			3.9	2	20	7.3-7.9-8.6×1.9-2.1-2.5 3.7 2 20		
C4	35	8.6-9.1-10.2×1.9-2.1-2.2			4.5	1	20	7.6-8.5-9.3×2.0-2.2-2.8 3.8 1 20		

*: not fully mature **: reared at room temperature (ca. 23°C) 1)-4): see Table 19

Table 23. Number of stumpy type of microbasic mastigophores in nematocysts clusters and that of those in the other parts of tentacles.

MA		Clh			C4
No. of medusae examined		1	2	3	1
tentacles	1	4+10	4+15	5+ 6	4+ 3
	2	5+11	5+17	3+ 4	2+ 5
	3	3+16	4+ 8	5+10	4+ 5
	4	4+11	5+14	4+ 2	7+ 6
total		16+48	18+54	17+22	17+19

as follows and they are shown in Fig. 14, O-P.

Large type: 7.6-8.6-9.5×2.0-2.4-3.0* μ , 3.5* 3* 30* (* see Table 20)

Small type: 6.0-6.4-7.0×1.6-1.9-2.0 μ , 3.5 3 30

It was observed that only 5 nematocysts were contained in the whole body of the planula borne to a male and female of the reared mature medusae (Nos. 4 and 6 in Table 19). Their size was 7.2-7.7-8.0×1.6-1.7-1.8 μ .

In some kinds of the nematocysts, there was a local variation in their size. The small type of microbasic mastigophores found in the polyp from Oshoro (C1-C2) is slightly larger than those found in the polyps from Muroran and Akkeshi; and atrichous isorhizes in the newly liberated medusa from Akkeshi are smaller than those from Oshoro and Muroran. In two kinds of nematocysts on tentacles of mature medusa, those found in the reared mature medusa at high temperature are smaller than those found in the reared mature medusa at low temperature (Table 22).

When all the type of microbasic mastigophores except for the stumpy ones found in the youngest medusa are competently squashed, the spirals on butt often appeared as rows of small spines, and are not clearly discernible from basitrichous isorhizes as is often the case in *Thecta-Leptomedusae*.

Systematic Considerations

From Japanese waters, one species of the medusa *Phialidium* has been reported (Maas, 1909; Uchida, 1925, '27, and '38), and 6 species and one variety of the polyp *Clytia* have been reported (Yamada, 1959; Hirohito, His Majesty the Emperor, 1969). No attempts to connect these polyps with medusae, however, have so far been done. All of the present specimens of the polyps collected from Hokkaido are identifiable with *C. edwardsi* (Nutting). The polyps of this species have already been recorded from several Japanese waters, Sagami Bay on the Pacific coast of central Japan, Matsuyama in the Seto Inland Sea of southern Japan, and Muroran on the Pacific coast of northern Japan (Stechow, 1913; Yamada, 1958 and '59; Kubota, 1976). The medusae of *C. edwardsi* from Hokkaido, which were clarified through the present investigation, coincide well with *P. hemisphaericum* in not only the external morphology but also the early embryonic stages (see Russell, 1953; Kramp, 1961 and '68; Bodo and Bouillon, 1968).

P. hemisphaericum has been reported from various waters such as the Indo-West-Pacific, the eastern Atlantic, and the Mediterranean, while it had never been reported in literature from the northern Pacific (Kramp, 1962 and '68)*. Recently Zelickman (1976) identified various stages of medusae collected from Aniva Bay, southern Sakhalin near Hokkaido, with *P. hemisphaericum*. The external morphology of his specimens coincides well with that of the present medusae. The medusae of *C. edwardsi* from Hokkaido is, therefore, identifiable with *P. hemisphaericum*, with which the medusae of *P. discoida* reported by Uchida (1925) is probably synonymous judging from their external morphology, locality, and seasonal occurrence.

On the other hand, *C. johnstoni* has been assigned to the polyp of *P. hemisphaericum* (Russell, 1953; Rees, 1957; Millard, 1966; Calder, 1974; etc.) and it has been regarded as a cosmopolitan species (Millard, 1975). The present polyps from Hokkaido are mostly identical with *C. johnstoni* from such the different parts of the world as England, New Zealand, South Africa, and North American Atlantic (Hincks, 1868; Ralph, 1956; Millard, 1966 and '75; Calder, 1975). It is noteworthy that the constitution of nematocysts of the present polyp and the grown medusa is the same as that of *C. johnstoni* and *P. hemisphaericum* (see Russell, 1938b). Furthermore, in the external morphology both of the polyp and medusa of the present hydroid coincide closely with *C. attenuata* (= *P. lomae*) from California reported by West and Renshaw (1970).

This morphological accordance among *C. edwardsi*-*P. hemisphaericum*, *C. johnstoni*-*P. hemisphaericum*, and *C. attenuata*-*P. lomae* suggests that they will be united to a single species. In order to justify to regard them as a single species, however, the following three characters must be fully re-examined to evaluate their taxonomic importance in the future: (1) the minute structure of inner diaphragm

* Roosen-Runge (1970) noted the occurrence of this species in Puget Sound and around the San Juan Archipelago.

of hydrotheca in polyp (see West and Renshaw, 1970); (2) the distribution of exumbrellar nematocysts in newly liberated medusa, and (3) the nematocyst cluster on the distal end of tentacles in newly liberated medusa.

Concluding Remarks

It has been known that wide morphological variations are observed in many characters of both polyp and medusa of some different species of *Clytia-Phialidium*, even in their important characters for classification, under both natural and cultured conditions (see Russell, 1938a and '53; Ralph, 1957; Millard, 1966 and '75; West and Renshaw, 1970; Roosen-Runge, 1970; etc.), and similar variations are also observed in both the polyp and medusa of the present hydroid from Hokkaido. The newly produced gonangia in the laboratory-reared polyp of the present species is markedly long and smooth, whilst they are short and corrugated in the materials from natural habitat; and most of the important characters of medusa such as the umbrellar size, the shape and size of gonads, and the number of tentacles, of marginal warts, and of statocysts, are much variable in the mature medusae reared in the laboratory or collected from the sea. The limitation of the numerous species of *Clytia-Phialidium* is, therefore, very difficult. Further biological investigations will reveal that most of polyps and medusae described as numerous different species must be treated as mere variants of fewer species.

On the other hand, several youngest medusae belonging to *Phialidium* were captured from Akkeshi Bay on July 4, 1975, and one youngest medusa was captured from Murooran on May 16, 1976. The latter was reared for about two months in the laboratory at the water temperature of $12 \pm 2^\circ\text{C}$. The measurements of this older medusa from Murooran 37 days old after capture is as follows (mm):

L=3.49, GL=0.48, GW=0.16, M=0.95, S=1.59, J=1.59, W=9.05, H=3.97,
V=0.56, Te=47, Tr=8, Tte=55, St=45, Stl=60.

It was observed that the number of tentacles and of statocysts of this medusa 51 days old did not change (Te=50, Tte=53, St=47, Stl=69). The external morphology of this medusa (Plate VII, 10) is different from that of the medusa of C1-C4 in such characters as the presence of more well-developed or total tentacles and statocysts, larger stomach, more frilled oral lips, and narrower velum. The characteristics of this medusa from Murooran are mostly in accord with those of *P. gregarium*, which is commonly distributed in the Pacific coast of North America. The number of tentacles and of statocysts of *P. hemisphaericum*, however, sometimes exceeds 32 and attains 58 (Kramp, 1968), overlapping with that of *P. gregarium*. It is noteworthy that the external morphology of reared medusa of *P. gregarium* reported by Roosen-Rungen (1970) closely resembles that of *P. hemisphaericum* when they died before mature 4 weeks after liberation, and similar gonangia as was produced in the present polyps reared in laboratory were found in the laboratory-reared polyps of *P. gregarium*. Kramp (1962), however, noticed

that the black pigmentation is exclusively found in *P. gregarium*, and it has never been found in other *Phialidium*-species. *P. lomae*, which seems to be synonymous with *P. hemisphaericum* as is mentioned above, is also reported from the Pacific coast of North America (Kramp, 1962 and '68), and most of the characters of this species coincide well with those of *P. gregarium*. And another related species, *P. languidum* which is commonly distributed in Atlantic coast of North America, closely resembles *P. hemisphaericum* (Kramp, 1961 and '62), to which *P. gregarium* is closely akin (Kramp, 1962). Kramp (1962 and '68) considered these four *Phialidium*-species of *P. hemisphaericum*, *P. languidum*, *P. lomae*, and *P. gregarium* are separate species, though West and Renshaw (1970) pointed out a possibility that they are geographical variants of a single species due to different water temperatures. The author dares say that *P. hemisphaericum* is possibly a cosmopolitan medusa as is the same case in its polyp of *C. johnstoni*. Further information, however, will be needed to treat them as a single species as is pointed out above (1)–(3).

Acknowledgements

The author wishes to express his hearty gratitude to Professor Mayumi Yamada, Hokkaido University, for his kind directions and reading of the manuscript. Sincere thanks are also due to Dr. Tatsunori Itô and Mr. Kooichi Konishi, Hokkaido University, who gave the author some materials from Oshoro Bay and valuable suggestions. The author is also indebted to the staff of the Oshoro Marine Biological Station, Akkeshi Marine Biological Station, and the Institute of Algological Research, Hokkaido University, who gave the author the data of sea water temperature and helped him for his field work. Sincere gratitude is due to Professor Emeritus Tohru Uchida, Hokkaido University, for his valuable suggestions and encouragement.

Summary

Clytia edwardsi (Nutting) is recorded from Hokkaido (Oshoro, Muroran, and Akkeshi) in northern Japan. The external morphology of the polyp and medusa, the early embryonic stages, and the nematocysts equipment on whole life stages as well as the process of gonangiogenesis and of metamorphosis of medusa are described and illustrated in detail, and the seasonal occurrence of this species in Oshoro Bay is reported. The medusa of *Clytia edwardsi* is identified with *Phialidium hemisphaericum* (L.), though two previously unknown characters are present in the newly liberated medusa.

References

- Bodo, F. et J. Bouillon 1968. Étude histologique du développement embryonnaire de quelques hydroméduses de Roscoff: *Phialidium hemisphaericum* (L.), *Obelia* sp. Péron et Lesueur, *Sarsia eximia* (Allman), *Podocoryne carnea* (Sars), *Gonionemus vertens* Agassiz. Cah. Biol. Mar. 9: 69–104.
- Calder, D. R. 1975. Biotic census of Cape Cod Bay: Hydroids. Biol. Bull. 149: 287–315.

- Hincks, T. 1868. A history of the British hydroid zoophytes. John van Voorst, London, 338pp.
- Hirohito, His Majesty the Emperor of Japan 1969. Some hydroids of the Amakusa Islands. Biol. Lab., Imperial Household, Tokyo, 1-32.
- Kramp, P. L. 1961. Synopsis of the medusae of the world. J. Mar. Biol. Ass. U.K. **40**: 1-469.
- 1962. Notes on some eastern Pacific species of *Phialidium* (Leptomedusae). Pacif. Sci. **16**(1): 25-29.
- 1968. The hydromedusae of the Pacific and Indian Oceans. Dana Rep. **63**: 1-162.
- Kubota, S. 1976. Notes on the nematocysts of Japanese Hydroids, I. J. Fac. Sci. Hokkaido Univ. Ser. VI, Zool. **20**: 230-243.
- Maas, O. 1909. Japanische Medusen. Abh. K. Bayer. Acad. Wiss. Suppl. Bd. **1**, 52pp. 3 pls.
- Mayer, A. G. 1910. Medusae of the world. II. Carnegie Inst. Washington, Publ. No. 109.
- Millard, N. A. H. 1966. The hydrozoa of the south and west coasts of South Africa. Part III. The Gymnoblastera and small families of Calyptoblastea. Ann. S. Afr. Mus. **48**: 427-487.
- 1975. Monograph on the Hydroida of southern Africa. *Ibid.* **68**: 1-513.
- Motoda, S. 1971. Oshoro Marine Biological Station, Hokkaido University, Japan. Bull. Plankt. Soc. Jap. **18**(1): 32-94. (In Jap., Eng. Abstract).
- Nutting, C. C. 1915. American hydroids. Part III. The Campanulariidae and the Bonnellidae. Smiths. Inst., U.S. Nat. Mus. Spec. Bull. **126pp.**, 27pls.
- Ralph, P. M. 1957. New Zealand thecate hydroids. Part I. Campanulariidae and Campanulinidae. Trans. R. Soc. N.Z. (Zool.) **84**: 811-854.
- Rees, W. J. 1957. Evolutionary trends in the classification of capitate hydroids and medusae. Bull. Brit. Mus. (Nat. Hist.) Zool. **4**: 455-534.
- Roosen-Runge, E. C. 1970. Life cycle of the hydromedusa *Phialidium gregarium* (A. Agassiz, 1862) in the laboratory. Biol. Bull. **139**: 203-221.
- Russell, F. S. 1938a. The Plymouth offshore medusa fauna. J. Mar. Biol. Assoc. U.K. **22**: 411-439.
- 1938b. On the nematocysts of Hydromedusae. *Ibid.* **23**: 145-165.
- 1953. The medusae of the British Isles. Anthomedusae, Leptomedusae, Limnomedusae, Trachymedusae and Narcomedusae, 530pp., 35 pls. London: Cambridge Univ. Press.
- Stechow, E. 1913. Hydroidpolyphen der japanischen Ostküste. Teil. II. Abh. Math. Phys. Klass. K. Bayer. Akad. Wiss. III. Suppl. Bd. II Abh., 162pp.
- Strong, L. H. 1925. Development of certain Puget Sound Hydroids and Medusae. Publ. Puget Sound Biol. Stat. **3**: 383-399.
- Uchida, T. 1925. Some hydromedusae from northern Japan. Jap. J. Zool. **1**(3): 77-100.
- 1927. Report of the biological survey of Mutsu Bay. 2. Medusae of Mutsu Bay. Sci. Rep. Tohoku Imp. Univ., Biol. **2**(3): 215-238.
- 1938. Report of the biological survey of Mutsu Bay. 32. Medusae from Mutsu Bay (Revised report). *Ibid.* **13** (1): 37-46.
- Vannucci, M. and L. C. Ribeiro. 1955. O ciclo reproductivo de *Clytia cylindrica* L. Agass., 1862. (Hydrozoa: Campanulariidae). Dusenya **6**(3/4): 69-81.
- West, D. L. and R. W. Renshaw 1970. The life cycle of *Clytia attenuata* (Calyptoblastea: Campanulariidae). Mar. Biol. **7**: 332-339.
- Yamada, M. 1958. Hydroids from the Japanese Inland Sea, mostly from Matsuyama and its vicinity. J. Fac. Sci. Hokkaido Univ. Ser. VI, Zool. **14**: 51-63.
- 1959. Hydroid fauna of Japanese and its adjacent waters. Publ. Akkeshi Mar. Biol. Stat. no. **9**: 1-101.

Zelickman, E. A. 1976. Fauna and ecological notes on coelenterata of Bousset Lagoon (Southern Sakhalin, Aniva Bay, Okhotsk Sea). Acad. Sci. Trudy Inst. Oceanol. **105**: 198-209.

Explanation of Plate VII

Figs. 1-9: Materials from Oshoro Bay; Fig. 10: Material from Muroran.

Fig. 1. Portion of colony on *Sargassum* and a newly liberated medusa (in an upper corner), \times ca. 5.

Fig. 2. A gonotheca with distinct corrugations.

Fig. 3. A newly liberated medusa showing exumbrellar nematocysts, \times ca. 2.5.

Fig. 4. A nematocyst cluster at the distal end of a tentacle of a newly liberated medusa.

Figs. 5-6. Laboratory-reared male mature medusae about 42 days old, 5: \times ca. 4, 6: \times ca. 7.

Fig. 7. Oral lips of mature medusa.

Fig. 8. A trematode parasitic on inside of umbrellar jelly, see Table 14, No. 6. \times ca. 7.

Fig. 9. Oral lips and radial canals abnormally developed.

Fig. 10. A laboratory-reared medusa about 40 days old, \times ca. 5.

Addendum

Table 5

Two polyp colonies from Oshoro Bay. Measurements (mm) are shown in the same order as Table 5.

10-VI-'76: 9P(L), 1.13-1.24-1.38, 0.28-0.30-0.31, 3.6-4.2-4.9, smooth or wavy, 0.09-0.11-0.13, 0.06-0.09-0.09, 3-3.0-3.

17-VI-'76 (on *Ulva*): 9S+2P(F), 0.97-1.16-1.31, 0.28-0.34-0.38, 3.0-3.4-3.8, 8-8.4-9, 0.16-0.19-0.28, 0.09-0.09-0.13, 4-4.8-7.

Table 22

Microbasic mastigophores on oral lip

C1g (22 days old): 7.9-8.7-9.5 \times 1.9-2.1-2.1 μ , 4.2, 1, 20.

C3 (38 days old): 7.0-7.9-8.5 \times 1.9-2.0-2.1 μ , 3.9, 1, 20.

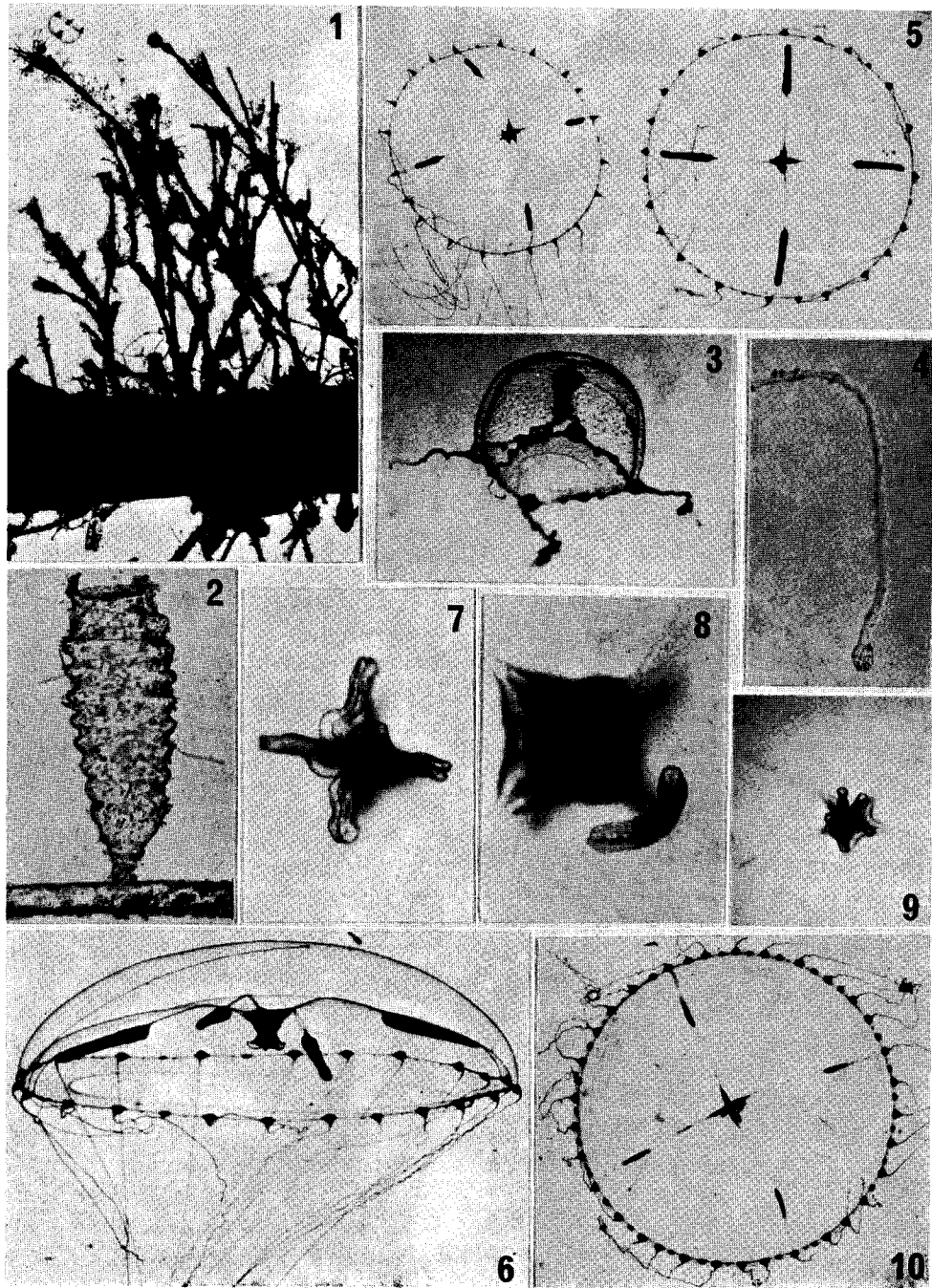

Sh. Kubota: *Life-history of Clytia edwardsi*