



HOKKAIDO UNIVERSITY

Title	Comparative ecology and ethology of sympatric soricine shrews in Hokkaido : A special reference to their interspecific interactions
Author(s)	OHDACHI, Satoshi; 大館, 智志
Degree Grantor	北海道大学
Degree Name	博士(理学)
Dissertation Number	甲第3530号
Issue Date	1995-03-24
DOI	https://doi.org/10.11501/3082543
Doc URL	https://hdl.handle.net/2115/28084
Type	doctoral thesis
File Information	thesis1995.pdf



Comparative Ecology and Ethology of Sympatric Soricine Shrews in Hokkaido:

A special reference to their interspecific interactions

by

Satoshi OHDACHI

A dissertation submitted in partial fulfillment of the
requirements for the degree of Ph.D. (Science)
at the Graduate School of Science,
Hokkaido University
1995

Doctoral Committee:

Professor Masanori J. Toda, Chairman

Professor Shunsuke F. Mawatari

Professor Hisashi Abe

Associate Professor Takayuki Ohgushi

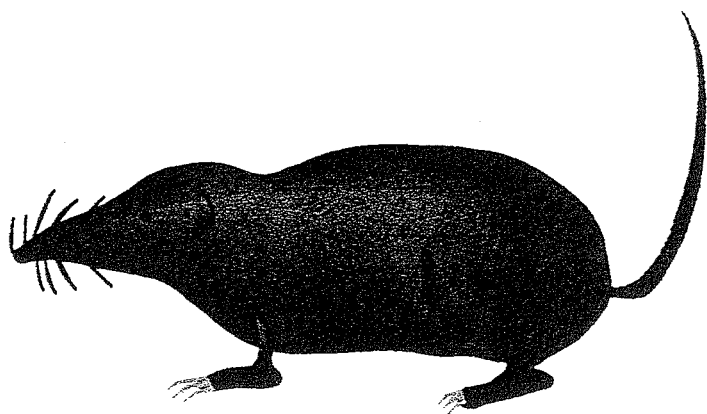

オオアシトガリネズミ *Sorex unguiculatus*

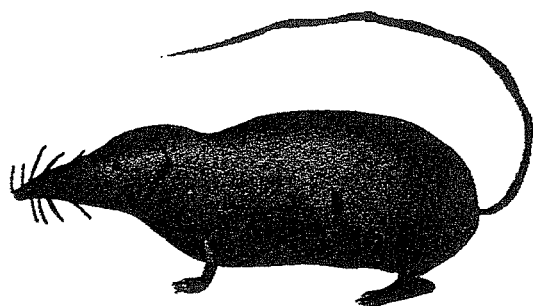

エゾトガリネズミ *Sorex caecutiens*

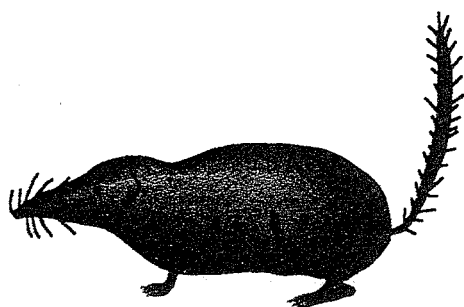

カラフトヒメトガリネズミ *Sorex gracillimus*

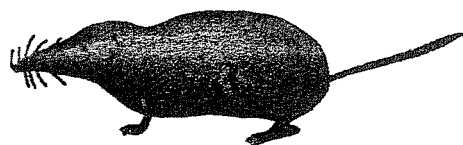

チビトガリネズミ *Sorex minutissimus*

by S. Okada

Contents

Chapter I General introduction.....	1
Chapter II Geographic distribution and relative abundance.....	5
Abstract.....	6
Introduction.....	6
Materials and methods.....	7
Results and discussion.....	12
Chapter III Diets and abundances during non-snow-covered seasons in northern Hokkaido.....	16
Abstract.....	17
Introduction.....	17
Materials and methods.....	18
Study area and habitat types.....	18
Trapping of shrews.....	19
Food resource conditions.....	21
Dietary analysis of shrews.....	22
Results.....	25
Abundance of shrews.....	25
Dietary analysis of shrews.....	27
Food resource conditions.....	31
Earthworm availability and consumption by <i>S. unguiculatus</i>	32
Discussion.....	33

Chapter IV	Patterns of daily activity.....	37
	Abstract.....	38
	Introduction.....	38
	Materials and methods.....	39
	Results.....	42
	Discussion.....	49
Chapter V	Burrowing habits and earthworm preferences.....	52
	Abstract.....	53
	Introduction.....	53
	Materials and methods.....	54
	Results and discussion.....	56
Chapter VI	Laboratory experiments of spatial use and aggression.....	59
	Abstract.....	60
	Introduction.....	61
	Materials and methods.....	63
	Experiment 1.....	63
	Experiment 2.....	66
	Results.....	69
	Experiment 1.....	69
	Experiment 2.....	74
	Dominance and attacks among shrews.....	80
	Discussion.....	82

Chapter VII Synthesis.....	87
Acknowledgments.....	93
Summary.....	95
Literature cited.....	98

Chapter I

General Introduction

Determinant for structuring ecological community varies among different communities. For instance, interspecific competition is a major force to organize some communities (Schoener 1983, but see also Connell 1983), while stability of environments (Chesson 1986) and predators (Menge & Sutherland 1976) determine the structure of other communities (see, Strong 1983, Shimada 1986, Itô *et al.* 1992 for more general discussion). Hence, the formation of a community is a unique event, which can not be replayed precisely (Schluter & Ricklefs 1993a), and it is pointless to emphasize and apply a single factor to organizations of all communities. Instead, if we compare the structures among communities under different circumstances, such as climate, geography, or phylogeny of community members, we can evaluate the relative importance of a certain factor to determine the community structure under a given condition.

A community which consists of members that have similar ecological requirements and use a similar habitat is called a "guild" (Root 1967). A local species assemblage of a certain taxon is potentially regarded as a guild, since phylogenetically close species usually have similar ecological requirements. We sometimes observe the convergence in guild structure among distant regions of similar environments (see, Schluter & Ricklefs 1993b). The convergence of guild structure could be caused by coevolution of guild members through interspecific interaction, limiting similarity among species invading into a region (competitive exclusion), or adaptation to environments of each guild member. To

examine relative importance of these potential causes, we must know histories of guilds, such as phylogenetic and geographic origins and speciation periods of guild members, as well as ecological and physiological characteristics.

Soricine shrews (the subfamily Soricinae, Insectivora) are distributed throughout boreal regions of the northern hemisphere, and approximately 86 species are known (Abe 1983, Macdonald 1984). Soricine shrew assemblages often consist of morphologically and ecologically "equivalent" species in various regions of the world (Abe 1983, 1985, Hanski 1989). Therefore, soricine shrews represent good subjects for investigating the convergence of guild structure and the roles of interspecific interactions for guild organization. In North America and Europe, a number of ecological studies of shrews have been conducted and interspecific relations among shrews have been well studied (e.g., *Annales Zoologici Fennici* vol. 26, 1989, *The Biology of the Soricidae*, special publication of the Museum of Southwestern Biology, University of New Mexico, 1991, and *Advances in the Biology of Shrews*, special publication of Carnegie Museum of Natural History, 1994). In contrast, only a few ecological studies have been conducted for shrews in the north-eastern Asiatic region including Hokkaido (e.g., Abe 1968, Okhotina 1974, Yoshino & Abe 1984, Dokuchaev 1990, Inoue & Maekawa 1990, Ohdachi 1992). Up to nine *Sorex* species coexist in this region (Stroganov 1957, Dolgov 1985) and the species diversity of soricids is the greatest in the world. Therefore, north-eastern Asia is a key region to reveal

the rule of guild organization and speciation of soricine shrews, and it is necessary to investigate the ecological characteristics of shrews there, especially, their interspecific relations.

The aim of this dissertation is to clarify differences in life history of shrews and to give fundamental information about competitive interactions among shrew species in Hokkaido, northern Japan. The dissertation consists of four parts of investigations (Chapters II–VI) and synthesis of these results (Chapter VII). In Chapter II, distribution and relative abundance of four soricine species in Hokkaido mainland and its neighboring islands (except for Sakhalin and Honsyu islands) are reported. In Chapter III, diets and abundances of *S. unguiculatus*, *S. gracillimus*, and *S. caecutiens* which are common in Hokkaido, are investigated. In Chapters IV–VI, behaviors, such as daily activity, burrowing habit, and space use, are examined for the three common species in laboratory. In the final chapter, I integrate the results obtained from Chapters II–VI and briefly discuss the role of interspecific interactions in soricid guilds of Hokkaido. Then, I compare the shrew assemblage in Hokkaido with those in other regions to find a general pattern of guild structure of soricids.

Chapter II

Geographic Distribution and Relative Abundance¹

¹A part of this chapter is the collaboration with Koji Maekawa (National Institute of Fisheries Science, Ueda, Nagano 386).

Abstract

Geographic distribution and relative abundance of four *Sorex* species were investigated in Hokkaido. *S. unguiculatus*, *S. caecutiens*, and *S. gracillimus* were distributed throughout the mainland of Hokkaido, and *S. minutissimus* was recorded only in the northern and eastern regions. *S. unguiculatus* was recorded on 11 out of 16 investigated islands near the mainland, *S. caecutiens* on one island, and *S. gracillimus* on 7 islands. *S. minutissimus* was not recorded on islands. *S. unguiculatus* was the most abundant species in 23 out of 33 habitats and was the second most abundant in the others. *S. caecutiens* was the second or third most abundant in 27 out of 33 habitats and was the most abundant in 6 habitats. *S. gracillimus* was less abundant in a majority of habitats (29 out of 33) but was the most abundant in moors and highlands of northern regions. *S. minutissimus* was the rarest species in Hokkaido. *S. caecutiens* and *S. gracillimus* did not occur together as the most and the second most abundant species.

Introduction

Four species of *Sorex* (*S. unguiculatus* Dobson, 1890, *S. caecutiens saevus* Thomas, 1907, *S. gracillimus* Thomas, 1907, and *S. minutissimus hawkeri* Thomas, 1906) are found in Hokkaido. Imaizumi (1960) and Abe (1967, 1988) reported the geographic distribution of shrews in Hokkaido, and other authors briefly mentioned the relative abundances of the

shrews in some regions and habitats (Abe 1968 1984, Abe *et al.* 1978, Maekawa 1981, Kondo 1983, 1986, Shimazaki & Masatomi 1986). However, difference in species composition has not been compared between regions or habitats throughout Hokkaido. In this chapter, I report the geographic distribution and the relative abundance of the four *Sorex* species throughout Hokkaido and on some of the neighboring islands.

Materials and methods

Collection locations and dates were shown in Table II-1. The samples from approximately two thirds of the locations examined were taken from the field, but the other data were cited from literature (Abe *et al.* 1978, Yoneda 1979, Kondo, 1983, 1986, Shimazaki & Masatomi 1986). Fifteen locations (13 locations on the mainland of Hokkaido and 2 locations on islands) and 33 habitats in total (31 habitats on the mainland and 2 habitats on islands) were investigated.

For the census of shrews, tin pit-fall traps (15 cm in diameter at the opening and 24 cm in depth) were used in the surveys from 1977 to 1981, polyethylene ones (16 cm in diameter and 20 cm in depth) in 1988, and plastic ones (8.5-cm diameter and 13 cm depth) after 1991. Traps were buried at ground level, and filled with water to a depth of approximately 5–10 cm. No baits were used for trapping. At each trap site 20–100 traps were arranged in two (or rarely four) lines. The distance between traps was 7 m in the

surveys from 1977 to 1981, and 5 m after 1988. Traps were set for one to ten night(s) in every survey. Animals were collected every day. In Daikoku island, Sherman live traps were used.

Table II-1. Collection locations and dates.

Study area	Date
A Kikonai	Mar. & Jun.-Oct. 1977
B Shikotsu	mid. Sep., 1977
C Tomakomai (Yufutsu meadow)	Apr.-Aug. 1977 & Jul. & Aug. 1980
D Sapporo (Tonden)	Apr.-Jun. 1979
E Furano (Exp. For., Univ. Tokyo)	early Jul. 1988
F Haboro	mid. Aug. 1977
G Toyotomi (Sarobetsu moor)	late Aug. 1991, late Jun. 1992, & late Jun.-early Jul. & mid. Sep. 1994 Jul. & Aug. 1972-76, 83, 84 ¹
H Rishiri island	early Jul. & mid. Sep. 1994
I Horonobe (Teshio Exp. For., Hokkaido Univ.)	May-Nov. 1988
J Shimokawa	late Aug.-early Sep. 1977 ²
K Koshimizu	each month 1974-77 ³
L Shiretoko pen.	May, Aug., & Nov. 1977 & Aug.-Nov. 1980
M Akkeshi	mid. Sep. 1985 ⁴
N Daikoku island	late Jul. 1979 & late May 1980
O Kushiro (Kushiro moor)	mid. Oct. 1983 ⁵

¹Shimazaki & Masatomi (1986), ²Abe *et al.* (1978), ³Yoneda (1979), ⁴Kondo (1986), ⁵Kondo (1983).

Abe *et al.* (1978) and Kondo (1983, 1986) used trapping methods similar to the present study. Shimazaki and Masatomi (1986) set 100 or 150 baited pit-fall traps for insect study (exact size was unknown, but they were obviously smaller than the trap of the present study) without

water at 1 m intervals for 8 nights. Yoneda (1979) used Sherman live traps.

Habitats were classified into the following 14 types based upon their vegetation types: (1) Wind-shelter belt of *Fraxinus mandshurica* in agricultural fields (Ws), (2) Deciduous forest dominated by *Quercus* spp., *Tilia* spp., *Acer* spp., and *Ulmus* spp. (Df), (3) Coniferous forest dominated by *Abies sachalinensis* and/or *Picea jezoensis* (Cf), (4) Spruce forest dominated by *Picea glehnii* (Sf), (5) The mixed forest of deciduous trees, fir *A. sachalinensis*, and spruce *P. jezoensis* (Mf), (6) Riparian forest dominated by *Salix* spp., *Alnus japonica*, and *Fraxinus mandshurica* (Rf), (7) Fir plantation mainly of *A. sachalinensis* with closed crown (Fp), (8) Larch plantation mainly of *Larix leptolepis* with closed crown (Lp), (9) Larch and birch plantation of *Larix* spp. and *Betula platyphylla* with partially closed crown (LBp), (10) Shrubland dominated by *Spiraea salicifolia*, *Lonicera caerulea*, and *Malus baccata* in Tomakomai (C), by *Sasa* spp., *Hydrangea paniculata*, and *Salix* sp. in Toyotomi (I), or by *Malus baccata* and *Euonymus sieboldianus* in Kushiro (O) (Sr), (11) Subalpine shrubland dominated by *Pinus pumila* and *Betula ermanii* above the forest line (Ss), (12) Grassland dominated by Graminae and Cyperaceae (Gr), (13) Herbaceous field dominated by tall succulent herbs such as *Petasites japonicus*, *Angelica ursina*, *Cirsium kamtschaticum*, and *Artemisia montana* with few ligneous plants (Hb), and (14) Moorland developed on peat bed (Mr).

Relative abundance of a species was evaluated by the percentage of the numbers of captured animals. When the data of relative abundance were not available for *S. gracillimus* and *S. minutissimus*, which were rare species in some regions, only collection locations were indicated in Fig. II-1. Data sources of these collection records were Obara & Nara (1984) in Shiriuchi (southwestern Hokkaido), H. Abe (pers. comm.) at Mount Soranuma (Sapporo), T. Shida (pers. comm.) in Oyafuru (Ishikari-cho), Imaizumi (1972) in the Hidaka Mountains (the southern Central Hokkaido), and my observation in the Daisetsu Mts. (central Hokkaido) for *S. gracillimus*, and Abe (1961), Komiya (1972), and Maekawa (1981) in eastern Hokkaido, and T. Shida (pers. comm.) in Kamishihoro for *S. minutissimus*.

For the survey of the presence of shrews on neighboring islands of Hokkaido mainland, 18 islands were selected (Fig. II-2). The data for 16 islands were obtained from published literature (Imaizumi 1960, Abe 1967, 1988, Miyao *et al.* 1970, Ohta 1970, Dolgov 1985, Asagawa & Asagawa 1991, Okhotina 1991, Kholin 1993), personal communications with H. Abe, N. Kondo, and K. Takahashi, and K. Maekawa's and my expeditions. The remaining two islands, Oshima-kojima and Kenbokki islands, lacked any data for small mammalian fauna.

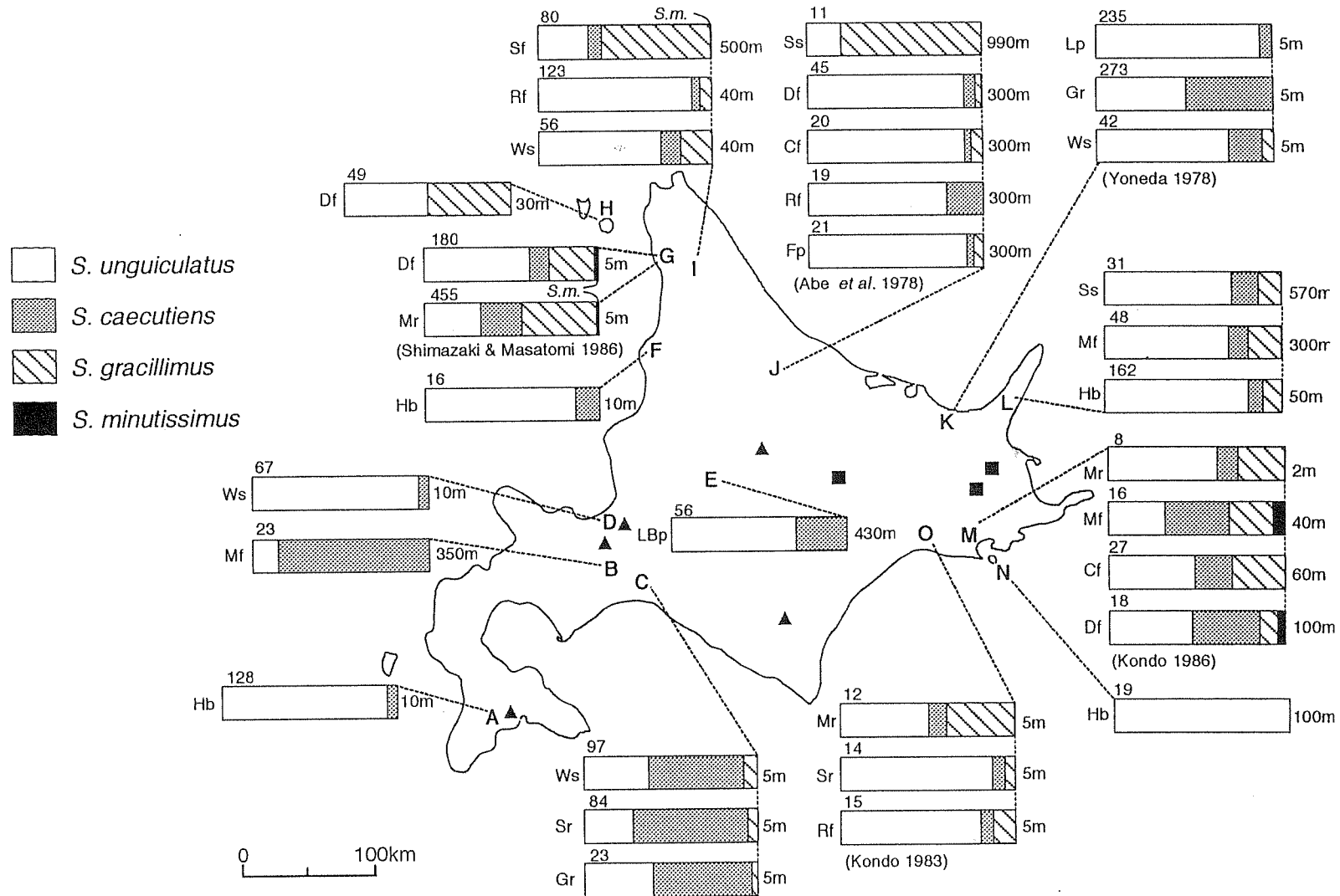

Fig. II-1. The geographic distribution and the percent composition of shrew species in Hokkaido. The letter on the left side of the bar-graph denotes habitat type (see text for abbreviations), and the number on the right side denotes altitude. The number on the upper left side indicates sample size. Small solid triangles and squares indicate the supplemental collection location for *Sorex gracillimus* and *S. minutissimus*, respectively.

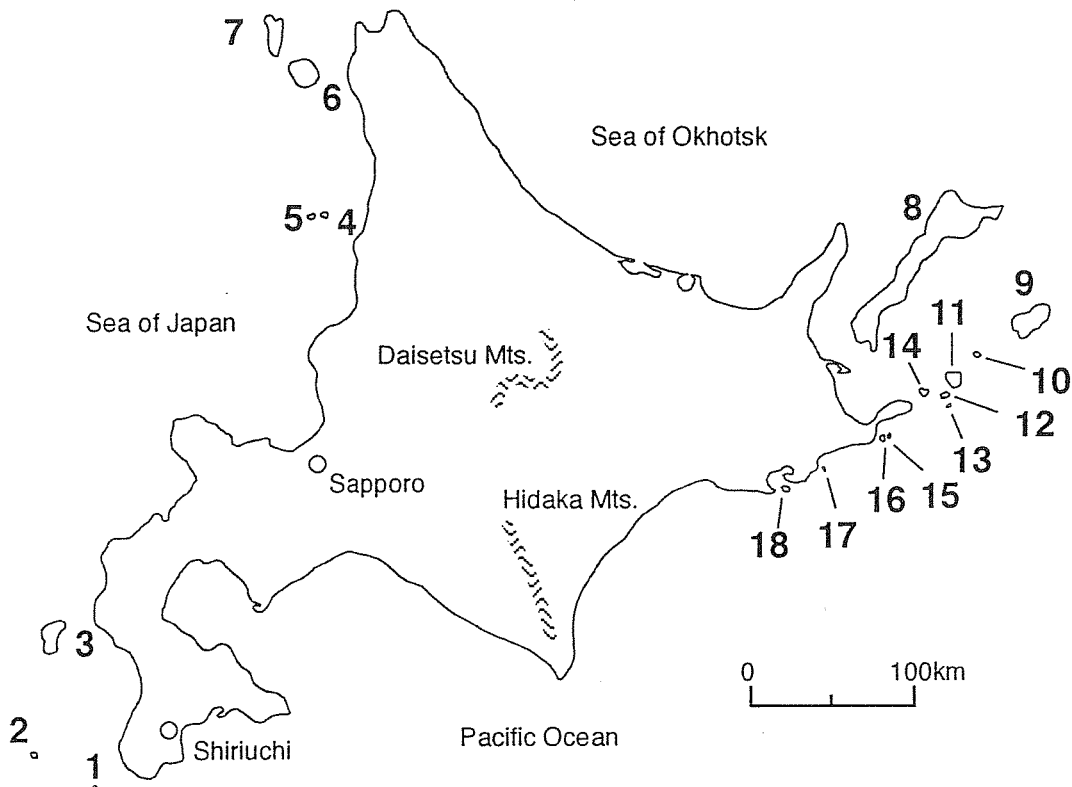

Fig. II-2. The location of 18 islands near the mainland of Hokkaido.

Results and discussion

S. unguiculatus occurred in all the locations and habitats examined on the mainland (Fig. II-1), and was recorded on 11 out of 16 islands where censuses for small mammals have been conducted (Table II-2). *S. unguiculatus* was the most abundant species in 23 out of 33 habitats examined; however, it was the second most abundant in the spruce forest (Sf) at 500 m in Horonobe (I), subalpine shrubland (Ss) at 900 m in Shimokawa (J), all habitats in Shikotsu (B), Tomakomai (C),

grassland (Gr) in Koshimizu (K), and the mixed forest (Mf) in Akkeshi (M) (Fig. II-1).

Table II-2. Collection records of soricine shrews on 18 islands near the mainland of Hokkaido. *S. u.*, *Sorex unguiculatus*; *S. c.*, *S. caecutiens*; *S. g.*, *S. gracillimus*; *S. m.*, *S. minutissimus*; nr, not recorded; R, recorded; -, no information for small mammalian fauna; (?), doubtful data.

No.	Island	Species			
		<i>S. u.</i>	<i>S. c.</i>	<i>S. g.</i>	<i>S. m.</i>
1	Oshima-kojima	-	-	-	-
2	Oshima-ohshima	nr	nr	nr	nr
3	Okushiri	nr	nr	nr	nr
4	Yagishiri	R(?)	nr	nr	nr
5	Teuri	R	nr	nr	nr
6	Rishiri	R	nr	R	nr
7	Rebun	R	nr	R	nr
8	Kunashiri	R	R	R	nr(?)
9	Shikotan	R	nr	R	nr
10	Taraku (Polonsky)	R	nr	R	nr
11	Shibotsu (Zelenyi)	R	nr	R	nr
12	Yuri	R	nr	nr	nr
13	Akiyuri (Anutchin)	R	nr	nr	nr
14	Suisho (Tanfil'yev)	R	nr	R	nr
15	Moyururi	nr	nr	nr	nr
16	Yururi	nr	nr	nr	nr
17	Kenbokki	-	-	-	-
18	Daikoku	R	nr	nr	nr

Numbers of the islands are the same as in Fig. 2. ^{1,17}No information for small mammalian fauna; ^{2,4,5}Ohta (1970), Asagawa & Asagawa (1991), H. Abe (pers. comm.); ³Ohta (1970), Asagawa & Asagawa (1991), K. Kondo (pers. comm.), K. Takahashi (pers. comm.), our records; ^{6,7}Imaizumi (1960), Abe (1967, 1988), Ohta (1970), Miyao *et al.* (1970), Asagawa & Asagawa (1991), our records; ⁸⁻¹⁴Imaizumi (1960), Abe (1967), Ohta (1970), Dolgov (1985), Okhotina (1991), Kholin (1993); ^{15,16}N. Kondo (pers. comm.); ¹⁸Abe (1967), Ohta (1970), Asagawa & Asagawa (1991), our records.

S. caecutiens occurred in all the locations and most habitats (30 out of 31) on the mainland (Fig. II-1), and was recorded on one island, Kunashiri (Table II-2). This species was the second or third most abundant in 27 out of 33

habitats examined; however, it was the most abundant in all the habitats in Shikotsu (B) and Tomakomai (C), grassland (Gr) in Koshimizu (K), and the mixed forest (Mf) in Akkeshi (M) (Fig. II-1). Soil of the habitats where this species was numerically dominant consisted of volcanic ashes (Shikotsu and Tomakomai) or sands (Koshimizu).

S. gracillimus occurred in 8 out of 13 locations and 23 out of 31 habitats examined on the mainland (Fig. II-1), and was recorded on 7 islands (Table II-2). This species was regarded as being distributed throughout the mainland, when supplemental collection records were considered. The relative abundance of this species was small in a majority of habitats (19 out of 24) where it occurred (Fig. II-1). However, it was the most abundant in higher lands and wet lands of northern regions and on Rishiri Island. In addition, Imaizumi (1972) reported that *S. gracillimus* was the dominant shrew in alpine areas of the Hidaka Mts. Thus, *S. gracillimus* seems to outnumber the other species in highlands and moors in Hokkaido, especially in the northern region.

S. minutissimus was found only in northern and eastern Hokkaido (Fig. II-1) and was not recorded on any island (Table II-2; the record from Kunashiri was ambiguous, see Dolgov 1985). This species occupied very small parts of species composition even in its distributional range (Fig. II-1). Larch plantation, the mixed forest, deciduous forest, and moor have been reported as the habitats of this species in Hokkaido, and these habitats are usually at low altitudes

(lower than 100 m) (Abe 1961, Komiya 1970, Kondo 1986, Shimazaki & Masatomi, 1986). I obtained this species from a relatively high altitude place (spruce forest at 500 m) in Horonobe (I). This is a new record on the distribution of *S. minutissimus* in Hokkaido.

The combination of the most and second most abundant species was either of *S. unguiculatus* and *S. caecutiens*, or *S. unguiculatus* and *S. gracillimus* in all the habitats examined (Fig. II-1). Further, *S. caecutiens* and *S. gracillimus* did not co-occur on most islands; the only exception was Kunashiri, which is much larger in area than the other islands. These findings suggest that there be a negative ecological interaction between *S. caecutiens* and *S. gracillimus*.

Chapter III

Diets and Abundances during Non-snow-covered Seasons in Northern Hokkaido

Abstract

Diets and abundances of three sympatric shrew species (*Sorex unguiculatus*, *S. gracillimus*, and *S. caecutiens*), food resource conditions, and environmental characteristics were investigated in three habitat types (riparian forest, wind-shelter belt, and spruce forest) during non-snow-covered seasons in northern Hokkaido. *S. unguiculatus* outnumbered *S. gracillimus* in the riparian forest and wind-shelter belt, and vice versa in the spruce forest. *S. caecutiens* was rare in the study area. Abundances of *S. unguiculatus* and *S. gracillimus* seemed to be unrelated with those of their principal foods. The main prey of *S. unguiculatus* was earthworms, whereas *S. gracillimus* and *S. caecutiens* mainly consumed small terrestrial arthropods. *S. unguiculatus* tended to consume more earthworms in the spruce forest than in the other habitat types. The consumption of earthworms appeared to reflect the relative availability of earthworms per capita. Food consumption of *S. gracillimus* did not varied among the habitat types.

Introduction

In some European shrew guilds, interspecific competition is a major determinant of the spatial and numerical relationships of sympatric species (e.g., Croin-Michielsen 1966, Ellenbroek 1980, Dickman 1988, 1991, Neet & Hausser 1990, Churchfield 1991). Fox and Kirkland (1992)

demonstrated non-random patterns in species assemblages of North American soricids and suggested that the non-random patterns be attributed to interspecific competition (see also Kirkland 1991). Thus, interspecific competition appears to play an important role in structuring some shrew guilds in Europe and North America. However, only a few studies have focused on interspecific relations between shrews in the north-eastern Asiatic region (e.g., Okhotina 1974, Yoshino & Abe 1984, Inoue & Maekawa 1990). In particular, interspecific difference in diet use must be investigated to detect potential competitive relationships among soricids in this region.

Herein, I investigated the diets and abundances of sympatric *Sorex unguiculatus*, *S. gracillimus*, and *S. caecutiens* during non-snow-covered seasons in northern Hokkaido, as well as food resource conditions and environmental variables in three habitat types, riparian forest, wind-shelter belt, and spruce forest. Then, I discuss what factors influence their abundances and food consumption.

Materials and methods

Study Area and Habitat Types

The study area was located in the Teshio Experimental Forest of Hokkaido University and its adjacent areas in northern Hokkaido. A general description of the study area is given elsewhere (Ohdachi 1992). The study was carried out

in the riparian forest, wind-shelter belt, and spruce forest during non-snow-covered seasons (April to November) in 1988–1990. Environmental characteristics of the three habitat types are summarized in Table III-1.

Table III-1. Environmental conditions of three habitat types in northern Hokkaido.

Source	Riparian forest	Wind-shelter belt	Spruce forest
Altitude	40 m	40 m	500 m
Topography	flat	flat	slope
Snow-covered period	mid. December to mid. April	mid. December to mid. April	late November to early May
Maximum Snow depth	1 m	1 m	2 m
Main tree species	<i>Salix</i> spp. <i>Alnus japonica</i> <i>Fraxinus mandshurica</i>	<i>F. mandshurica</i> <i>Betula platyphylla</i> <i>Hydrangea paniculata</i>	<i>Picea glehnii</i> <i>Betula ermanii</i>
Under growth	tall herbs <i>Sasa kurilensis</i>	<i>Sasa senanensis</i> tall herbs, ferns	<i>Sasa kurilensis</i>
Litter layer	broad leaves + herbs	broad leaves + <i>Sasa</i>	<i>Sasa</i> + <i>Picea</i>
Soil type	clay	clay-loam	clay-loam (serpentite)
Soil structure	massive	granular	massive
Soil hardness	3.00 kg/cm ²	1.57 kg/cm ²	1.36 kg/cm ²

Trapping of shrews

Trapping of shrews was conducted in the three habitat types once a month from May to November in 1988, April to November in 1989, and May to July in 1990. Polyethylene pit-fall traps (16-cm diameter at the opening and 20-cm deep) were used from May to November of 1988, in April of

1989, and from May to July of 1990. Twenty traps were set in two parallel lines of 10 traps with a 5-m interval between traps and between lines. As a rule, trap sites were moved into different places each month. No baits were used and water was poured 10-cm deep into traps to kill shrews quickly. Trapping sessions were 2–4 (usually 3) nights, and animals were removed every day. From April to November in 1989, smaller vinyl pit-fall traps (8-cm diameter at the opening and 13.5-cm deep) were also used for trapping shrews. These traps were the same ones that were used for collecting terrestrial arthropods (see next section for trapping procedure). Shrews were collected every day, whereas arthropods were collected on the last day. Abundance of shrews was expressed as the number of animals captured per 100 trap-nights (No./100TN). One *S. minutissimus* was captured in the study area (Chapter II), but omitted from the present study.

Chi-square tests were employed to compare relative abundance of shrew species between the habitat types (H_0 : the relative abundance does not differ between habitat types) and abundances of each species among the three habitat types (H_0 : a shrew species is evenly distributed among three habitat types). The expected values of the latter test were proportional to sampling efforts (trap-nights). The sequential Bonferroni technique (Rice 1989) was applied when needed.

Food resource conditions

Biomass of earthworms (Megascolecidae and Lumbricidae) in the soil was estimated from samples obtained from April to November in 1989. Three soil cores (30 by 30-cm² area by 20-cm depth without litter layers) were sampled monthly in each habitat type. Earthworms were collected from the soil cores manually and preserved in 70% ethanol. Later, they were dried in an oven at 60 °C for 24 hours and weighed to the nearest 0.1 mg.

Activity of small arthropods on the ground surface was investigated from April to November in 1989. Arthropods were collected by the vinyl pitfall traps described in the previous section. A solution of 1% formalin and 1% kitchen detergent was poured 2–5 cm deep into the traps. Twenty pitfalls were set in two lines of 10 traps with a 1-m interval and were deployed for 3–5 nights at each plot. As a rule, trap sites were changed each month. In the riparian forest, however, traps were set at nearly the same site after May in 1989, since alternative trap sites were destroyed by logging.

Arthropods were collected along with sediments on the last day of each survey. These samples were sieved through a 2-mm wire-mesh sieve. Then, arthropods were manually segregated from the sediments and preserved in 70% ethanol. Later, arthropods were sorted into major taxonomic groups (usually at family level), and the number of individuals of each taxon was recorded. Arthropods less than 1 mm in maximum length, which were not sieved out, were ignored.

Activity (or relative density) of arthropods was expressed by the number of arthropods captured per 100 trap-nights (No./100TN).

Wilcoxon's signed rank tests were employed to compare earthworm biomass and activity of arthropods between habitat types. The sequential Bonferroni technique (Rice 1989) was applied to the analyses.

Dietary analysis of shrews

Three hundred and two *S. unguiculatus*, 122 *S. gracillimus*, and 33 *S. caecutiens* were used for dietary analysis. Entire digestive tracts, from stomach to rectum, were removed and preserved in 70% ethanol or 10% formalin. A digestive tract was dissected in a glass vessel and all contents were extracted. The contents were strained through a plankton net, and remains were placed into another vessel. Then, a piece of glass slide was placed over the remains with water or 70% ethanol so that all content items were evenly distributed. Each item of the contents was identified under a binocular microscope, compared with reference specimens. Then, the number of unit squares of the ocular lens ruler (20 by 20 squares) which a specific item occupied was counted under 7x magnification.

Digestive tract contents were divided into 12 categories: earthworms (Megascolecidae and Lumbricidae), snails and slugs (Gastropoda), larval lepidopterans, adult coleopterans, larval coleopterans, adult ants (Formicidae), other insects,

spiders & harvestmen (Araneae and Opiliones), centipedes (Chilopoda), other arthropods, plants, and other materials.

Food items were quantified by the percent frequency of occurrence ($F\%$), percent volume index ($V\%$), and average volume index per capita (AVI). They were calculated as follows:

$$F\%_j = (n_j/N) \times 100,$$

$$V\%_j = \left(\sum_i V_{ij} \right) / \left(\sum_i \sum_j V_{ij} \right) \times 100,$$

$$AVI_j = \left(\sum_i V_{ij} \right) / N,$$

where $F\%_j$ = the percent frequency of occurrence for item j , $V\%_j$ = the percent volume index for food item j , AVI_j = the average volume index of food item j , V_{ij} = the number of unit squares of the ocular lens ruler for item j in the digestive tract of individual i (= volume index), N = the total number of shrews examined, s = the number of food categories, and n_j = the number of individuals that contained item j . The percent volume index was used for the comparison of food item volume among species, and the average volume index for the comparison of food consumption by a certain species among the habitat types.

Similarity of food consumption between shrew species was calculated as follows (after Schoener 1970):

$$C_{kh} = 1 - 1/2 \sum_j^s |V\%_{kj} - V\%_{hj}|,$$

where C_{kh} = the similarity of food consumption between species k and h , $V\%_{kj}$ = the volume index percentage for food item j of species k , and $V\%_{hj}$ = that of species h . Note that C_{kh} is zero when species k and h share no food items and 1.0 when they have identical food consumption.

Dietary niche breadth (B) was calculated as follows (after Levins 1968):

$$B = 1 / \sum_j^s (V\%_j / 100)^2$$

Chi-square tests were used to compare the proportion of frequency occurrence of each food category between the habitat types (H_0 : proportion of frequency occurrence of each food category does not differ between the habitat types) and the frequency occurrence among the three habitat types for each food category (H_0 : shrews use evenly a food category among the three habitat types). The expected values in the latter test were proportional to the total numbers of digestive tracts examined. The sequential Bonferroni technique (Rice 1989) was applied when needed. Analysis of variance (Scheffé's method) was used to compare the average volume index (AVI) between the habitat types for each food category.

Results

Abundance of shrews

In 1988, relative abundances of shrew species differed significantly among the three habitat types ($P < 0.05$). *S. unguiculatus* was the numerically dominant in the riparian forest and wind-shelter belt, whereas *S. gracillimus* was the dominant in the spruce forest (Fig. III-1-A). *S. caecutiens* was the numerically least dominant in all the habitat types. The numerical relationships among species in 1989 were similar to those in 1988 (Fig. III-1), although statistical tests could not be conducted between the riparian forest and the other two habitats due to insufficient data.

In 1988, abundance of *S. unguiculatus* differed significantly ($P < 0.05$) among three habitat types. *S. unguiculatus* was more abundant in the riparian forest and wind-shelter belt than in the spruce forest (Fig. III-1-A). In 1989, *S. unguiculatus* differed significantly ($P < 0.05$) in abundance among the three habitat types, and was more abundant in the wind-shelter belt than in the other two habitat types (Fig. III-1-B). However, the reduced abundance in the riparian forest was presumably caused by over-trapping; because alternative trapping plots in the riparian forest were destroyed by logging in May of 1989, I had to conduct trapping at the same site thereafter. *S. gracillimus* differed significantly ($P < 0.05$) in abundance among the habitat types in both 1988 and 1989, and was most abundant

A. 1988

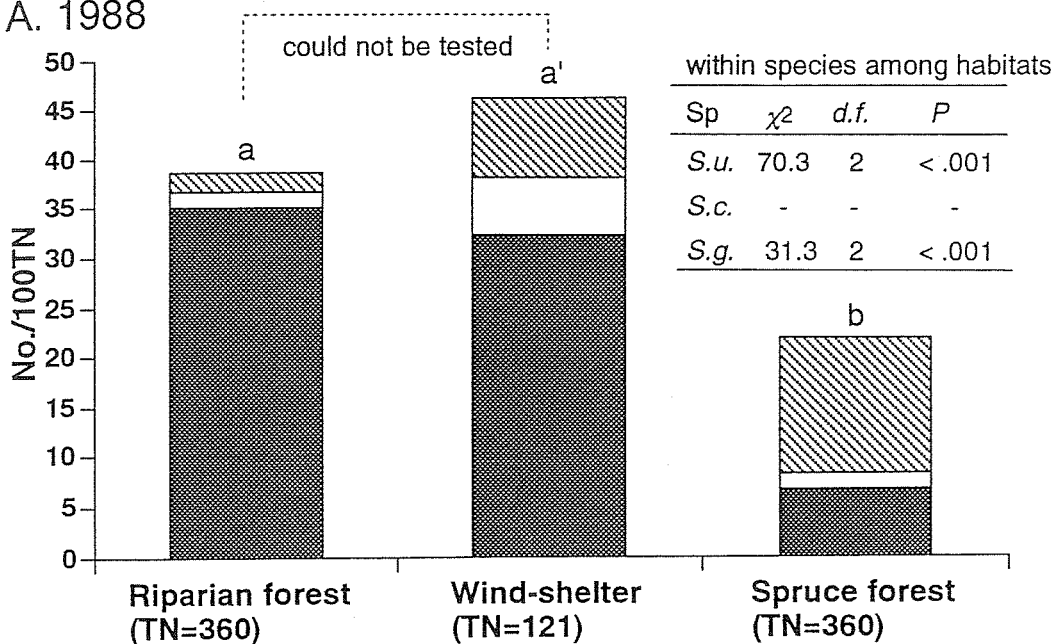

B. 1989 (small trap)

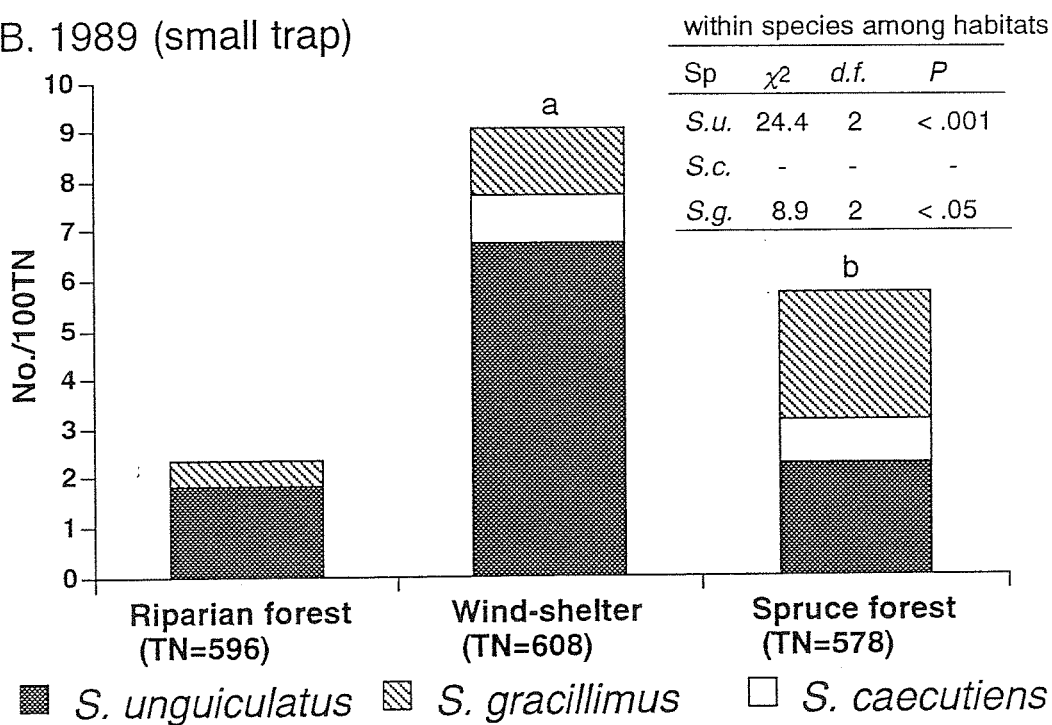

Fig. III-1. Abundances of *Sorex unguiculatus*, *S. gracillimus*, and *S. caecutiens* in the three habitat types. Letters above bars indicate a significance difference ($\alpha=0.01$) according to Chi-square tests (H_0 : proportion of the three species does not differ between habitats); the same letters indicate non-significant difference. Note that statistical tests could be done neither between the riparian forest and wind-shelter in 1988, nor between the riparian forest and the other two habitats, due to insufficient sample size. Tables in the figure indicate the result of one-sample Chi-square tests for abundance of shrews between habitat in each species (H_0 : abundance of a shrew species does not differ among the three habitats). Note that different kinds of pitfall traps were used between 1988 and 1989, and the number of captured shrews per 100 trap-nights can not be compared directly between the two years.

in the spruce forest (Fig. III-1). The abundance of *S. caecutiens* could not be compared statistically among the habitat types due to small sample sizes.

Table III-2. Breadth and similarity of dietary niches in *Sorex unguiculatus*, *S. gracillimus*, and *S. caecutiens*. Formulae for calculating the breadth and similarity are given in the text. Following 12 food categories were used for the calculation: earthworms, snails & slugs, larval lepidopterans, adult coleopterans, larval coleopterans, ants, other insects, spiders & harvestmen, centipedes, other arthropods, plants, and other foods.

Species	N	Breadth	Similarity	
			vs.	
<i>S. unguiculatus</i>	302	4.27	-	-
<i>S. gracillimus</i>	122	5.56	0.34	-
<i>S. caecutiens</i>	33	4.61	0.45	0.62

Dietary analysis of shrews

The diets of *S. unguiculatus* and *S. gracillimus* differed considerably, while that of *S. caecutiens* was intermediate between the other two species but more similar to *S. gracillimus* (Table III-2). Earthworms and gastropods (slugs & snails) were major constituents in the diet of *S. unguiculatus* (Fig. III-2-A). This shrew also consumed small epigeal arthropods such as insects, spiders & harvestmen, and centipedes, although their volume index percentages were small. In contrast, *S. gracillimus* did not eat earthworms at all and consumed slugs & snails very little (Fig. III-2-B). Main

A. *S. unguiculatus* (N=302)

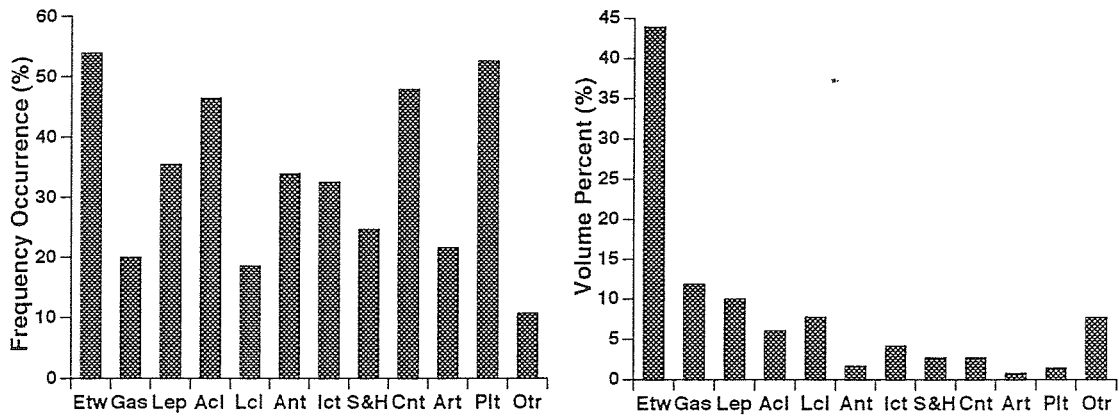

B. *S. gracillimus* (N=122)

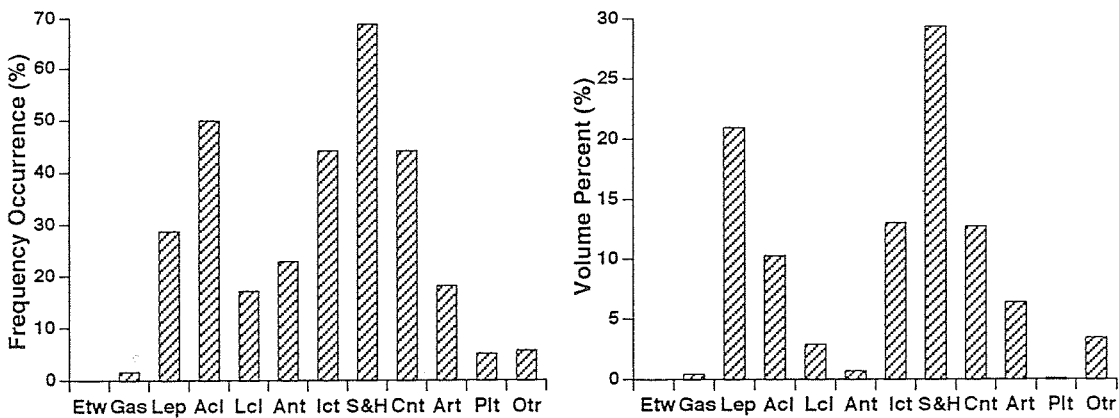

C. *S. caecutiens* (N=33)

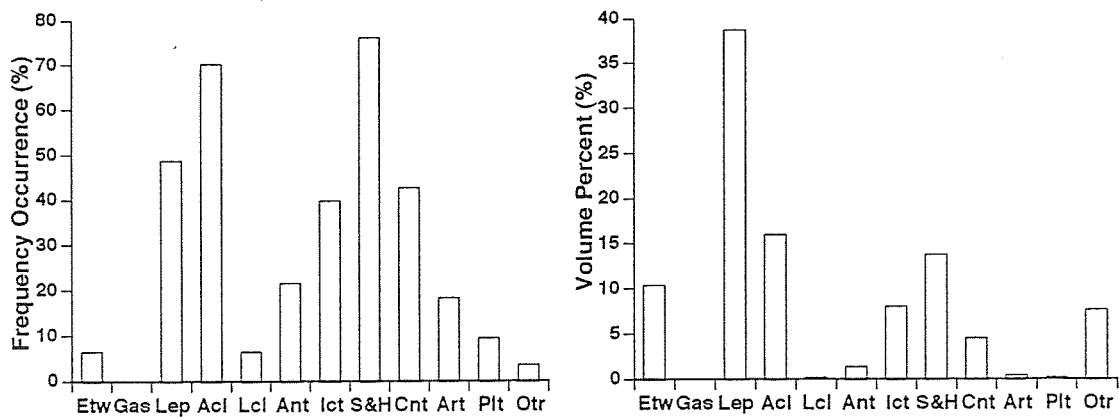

Fig. III-2. Interspecific differences in diet use (the percent frequency of occurrence and percent volume index) among *Sorex unguiculatus*, *S. gracillimus*, and *S. caecutiens*. Etw, earthworms; Gas, snails & slugs; Lep, larval lepidopterans; Acl, adult coleopterans; Lcl, larval coleopterans; Ant, adult ants; Ict, other insects; S&H, spiders & harvestmen; Cnt, centipedes; Art, other arthropods; Plt, plants; Otr, other food items.

A. *S. unguiculatus*B. *S. gracillimus*

Fig. III-3. Differences in diet use (the percent frequency of occurrence and average volume index per capita) among the three habitats in *Sorex unguiculatus* and *S. gracillimus* in northern Hokkaido. Letters above bars of the graphs of frequency occurrence are the result of one-sample Chi-square tests (H_0 : frequency occurrence of a food category does not differ among the three habitat types); ** = $P < 0.01$, * = $P < 0.05$, ns = $P \geq 0.05$. Letters above bars of the graphs of average volume index indicate a significant difference ($\alpha = 0.05$) according to ANOVA with Scheffes method (H_0 : average volume index for a food category does not differ significantly among the three habitats). When the same letters are included between the habitat types, the difference is not significant. Tables in the graph of frequency occurrence are the result of Chi-square tests (H_0 : proportion of frequency occurrence does not differ between the habitat types; Etw, Gas, Lcl, Plt, and Otr were omitted from the analysis for *S. gracillimus*). See Fig. III-2 for abbreviations.

prey items of *S. gracillimus* were small arthropods, such as spiders & harvestmen, centipedes, and insects. The main prey of *S. caecutiens* also was epigeal arthropods, especially larval lepidopterans (Fig. III-2-C). In addition, this species consumed earthworms. The breadth of dietary niche was greatest in *S. gracillimus* and least in *S. unguiculatus* (Table III-2), although the number of food categories eaten by the latter species was greater than the former. The narrower niche breadth of *S. unguiculatus* was due to its intensive consumption of earthworms.

Foods consumed by *S. unguiculatus* varied among the habitat types (Fig. III-3-A). The frequency occurrences of 12 food categories differed significantly ($P < 0.05$) between the riparian forest and wind-shelter belt. Within each food category, the frequencies of larval coleopterans and other insects varied significantly among the habitat types. The average volume indices of earthworms and larval lepidopterans differed significantly among the habitat types. The dietary niche breadth varied among the habitat types in *S. unguiculatus* (Table III-3). The breadth was narrowest in the spruce forest, which reflected the high consumption on earthworms there.

In *S. gracillimus*, the compositions of the frequency occurrences of 7 food categories did not vary significantly ($P \geq 0.05$) among the habitat types (Fig. III-3-B). In addition, no frequency occurrence for each food category differed significantly ($P \geq 0.05$) among the habitat types. Only the average volume index of adult coleopterans varied

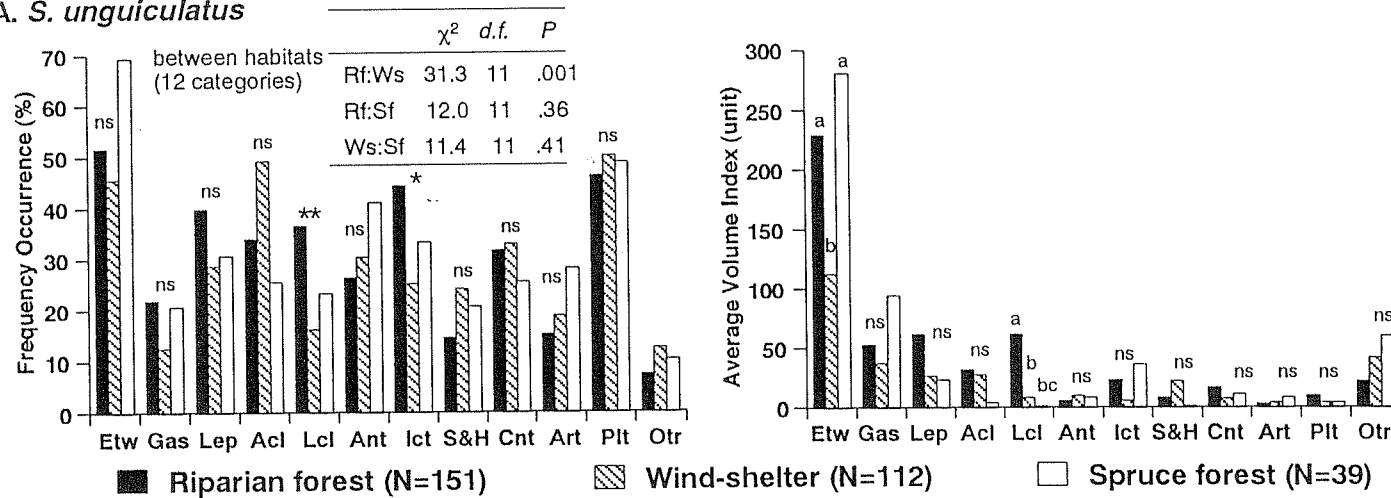
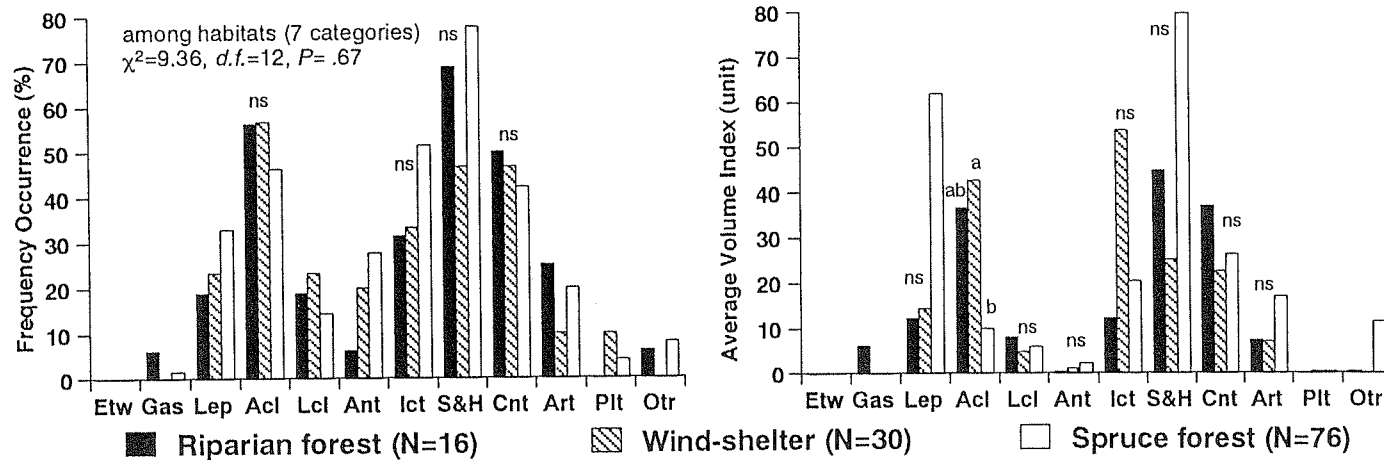
significantly among the habitat types. The niche breadth tended to be constant among the habitat types, compared with *S. unguiculatus* (Table III-3).

Table III-3. Changes in the dietary niche breadth and similarity for *Sorex unguiculatus* and *S. gracillimus* among the three habitat types.

Habitat types	Riparian forest	Wind-shelter belt	Spruce forest
Breadth			
<i>S. unguiculatus</i>	4.15	5.04	3.00
<i>S. gracillimus</i>	5.25	4.77	4.64
Similarity	0.32	0.33	0.22

In *S. caecutiens*, dietary compositions were not compared between the habitat types, owing to small sample sizes. I just note that this species consumed earthworms only in the wind-shelter belt.

Food resource conditions

Biomass of earthworms was significantly greater in the riparian forest than in the wind-shelter belt and spruce forest, but did not differ significantly between the latter two habitats (Fig. III-4). The capture of arthropods (No./100TN) was also significantly greater in the riparian forest than in the other two habitats (Fig. III-4). In addition, the captures of adult small coleopterans and ants were obviously greatest in the riparian forest and that of centipedes was greatest in the

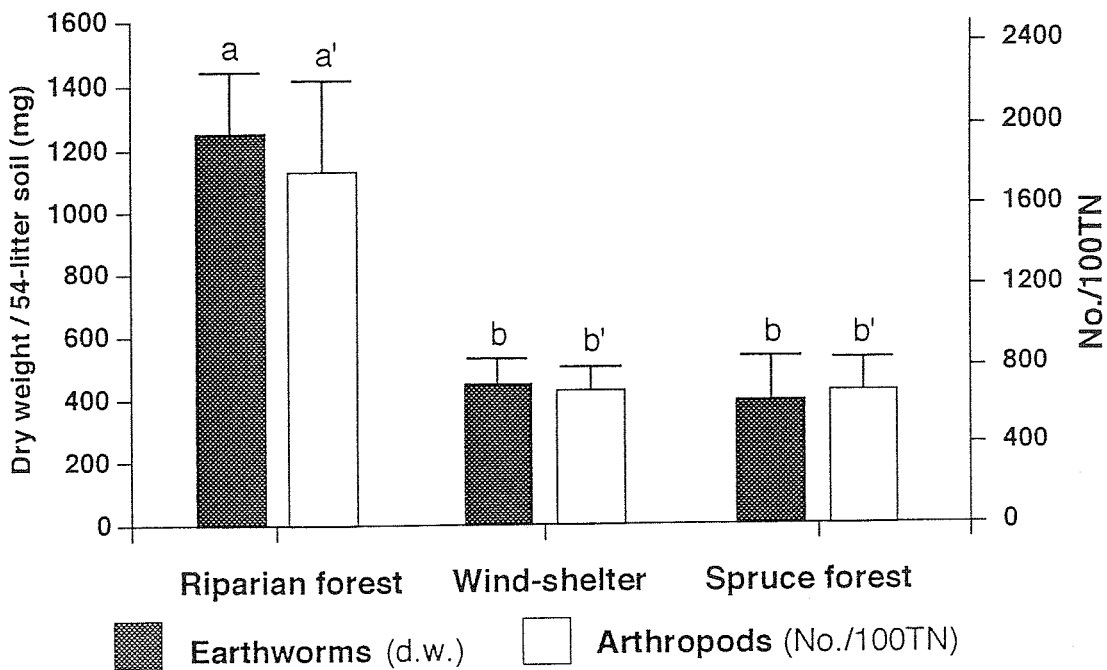

Fig. III-4. Captures of arthropods (mean No./100TN + S.E.) and biomass of earthworms in the soil (mean dry weight per 54-litter soil + S.E.) in the three habitat types. The same letters above bars indicate non-significance difference ($P \geq 0.05$) between the habitat types according to Wilcoxon's signed rank tests.

wind-shelter belt, while the other arthropods showed unclear difference in relative abundance between the habitat types.

Earthworm availability and consumption by S. unguiculatus

The relative earthworm availability per individual *S. unguiculatus* was highest in the spruce forest and lowest in the wind-shelter belt (Table III-4). The average volume index for earthworms was positively related with the availability per individual shrew. On the other hand, earthworm consumption by *S. unguiculatus* population was the highest in the riparian forest, which reflected the greatest earthworm biomass there.

Table III-4. Biomass in the soil, relative availability, and relative consumption of earthworms by *S. unguiculatus* in the three habitat types. Numbers in parentheses are relative values when that in the spruce forest is 1.0.

	Riparian forest	Wind-shelter belt	Spruce forest
1. Earthworm biomass (mg/594-litter soil)	9995.1 (3.17)	3571.8 (1.13)	3157.2 (1)
2. No./100TN of <i>S. unguiculatus</i>	35.00 (5.25)	32.23 (4.83)	6.67 (1)
3. Relative availability	285.6 (0.60)	110.8 (0.23)	473.3 (1)
4. AVI for earthworms (unit)	229.1 (0.82)	112.4 (0.40)	279.9 (1)
5. Earthworm consumption by <i>S. u.</i> population	8018.5 (4.30)	3622.7 (1.94)	1866.9 (1)

¹Total biomass of earthworms.

²No./100TN of *S. unguiculatus*.

³Biomass/(No./100TN).

⁴Average volume index per individual *S. unguiculatus* for earthworms.

⁵(No./100TN)x(AVI of earthworms).

Discussion

The abundance of shrews in northern Hokkaido did not appear to be determined solely by the food abundance of habitats (biomass of earthworms and surface activities of arthropods) during non-snow-covered seasons. If a population of an animal species is at equilibrium, food abundance may determine the equilibrium abundance of the animal (e.g., Brown 1969). Under such conditions, shrews should be abundant in habitats where their principal prey is abundant. In fact, Butterfield *et al.* (1981) and Yalden (1981)

reported that abundances of *S. araneus* and *S. minutus* in Europe were related to the abundance of their principal prey. If this is the case also in the shrews of Hokkaido, both of *S. unguiculatus* and *S. gracillimus* should be most abundant in the riparian forest and less abundant in the wind-shelter belt and spruce forest, since earthworms and small epigeal arthropods were much more abundant (or more active) in the former habitat than in the latter two (Fig. III-4). These predictions, however, were not confirmed in the present study (Fig. III-1; except for the result of *S. unguiculatus* in 1989 because there seemed to be sampling bias in the riparian forest; see result section for details). Thus, the biomass of earthworms and the soil surface activities of arthropods did not determine the abundances of *S. unguiculatus* and *S. gracillimus*.

Then, what determined the shrews' abundance? One factor might be abiotic environmental conditions of the habitat types. *S. unguiculatus* tended to be more abundant and *S. gracillimus* less abundant in the riparian forest and wind-shelter belt than in the spruce forest (Fig. III-1, except for the data in 1989). Common abiotic conditions shared by the riparian forest and wind-shelter belt were altitude, snow-covered period, and snow depth (Table III-1). These conditions differed between the spruce forest and the other two habitat types (Table III-1; see also Fujiwara *et al.* 1994). Furthermore, distributional survey throughout Hokkaido showed that *S. gracillimus* tended to outnumber *S. unguiculatus* at higher habitats and wet lands (Chapter II)

and that the relative abundance of the former species tended to be greater in northern regions than in central and southern regions (Ohdachi, personal observation). It is, therefore, feasible that abiotic environmental conditions may have affected the abundances of *S. unguiculatus* and *S. gracillimus* even on the local scale within the study area.

Dietary niche of *S. unguiculatus* was very narrow in the spruce forest (Table III-3), which was attributed to the high earthworm consumption there (Fig. III-3). This may have been caused by increased availability of earthworms per capita in the spruce forest. Some factors, such as temperature and snow depth, would limit the abundance of *S. unguiculatus* in the spruce forest. As a result, the low density led to the high availability of earthworms per individual *S. unguiculatus* there (Table III-4). This would reduce the intraspecific competition for earthworms, and thereby promoting the high consumption of earthworms.

The potential interspecific relationships between *S. caecutiens* and the other two species merit discussion. *S. caecutiens* was the rarest among the three shrew species in the study area (Fig. III-1), but it is numerically dominant in some other parts of Hokkaido (Chapter II). The relationships in the relative abundance suggested the existence of negative interaction between *S. caecutiens* and *S. gracillimus* (Chapter II). *S. caecutiens* was more similar in the dietary niche to *S. gracillimus* than to *S. unguiculatus* (Table III-2; see also, Abe 1968, Inoue & Maekawa 1990). Therefore, interspecific

competition, if any, would be more severe between *S. caecutiens* and *S. gracillimus* than between *S. caecutiens* and *S. unguiculatus*.

Chapter IV

Patterns of Daily Activity

Abstract

Daily activity rhythms of three soricine shrews were investigated in laboratory, using 19 *S. unguiculatus*, 13 *S. caecutiens*, and 11 *S. gracillimus* which were captured from the field. Total activities of shrews were measured by an infrared sensor system, under two different laboratory regimes (16L8D & 20 °C and 10L14D & 5–15 °C). All the three shrew species were more active during periods of darkness than during the light periods; however, during the light periods most of *S. gracillimus* and some of *S. unguiculatus* and *S. caecutiens* exhibited short intermittent activity. Activity during the dark periods was polymodal in all the three species under the 10L14D & 5–15 °C regime, but was bimodal in *S. unguiculatus* under the 16L8D & 20 °C regime. The actogram pattern of *S. caecutiens* proved to be intermediate between *S. unguiculatus* and *S. gracillimus*. Interspecific differences in activity pattern seem to be related to body size in the genus *Sorex*.

Introduction

Interspecific comparison of behavior and activity patterns is necessary to investigate physical interactions among sympatric species. Yoshino and Abe (1984) described the daily activity rhythms of *S. unguiculatus* and *S. caecutiens*, observing the behavior of shrews in cages that contained soil and litter under uncontrolled room condition.

They observed only ground surface activities, although *S. unguiculatus* shows strong subterranean nature (Chapters V and VI). Furthermore, they observed shrew activity only during summer. Since some shrew species change their activity patterns from season to season (e.g., Lardet 1988), seasonal variation in activity should also be investigated.

I invented an infrared sensor system that measures total activity of shrews. Total activities of *S. unguiculatus*, *S. caecutiens*, and *S. gracillimus* were recorded by using the sensor system under two different laboratory conditions (16L8D & 20 °C and 10L14D & 5–15 °C). Then, the results were compared with those of the previous study for *S. unguiculatus* and *S. caecutiens* (Yoshino & Abe 1984) and those of other soricine shrew species.

Materials and methods

Nineteen *S. unguiculatus* (8 young females, 9 young males, 1 sex-unknown juvenile, 1 adult female), 13 *S. caecutiens* (3 young females, 7 young males, 2 sex-unknown juveniles, 1 adult male), and 11 *S. gracillimus* (5 young females, 6 young males) were studied. Of the 43 animals, 4 *S. unguiculatus* and 7 *S. caecutiens* were captured from Yufutsu moor (Tomakomai) between 14 and 18 June 1992, and 15 *S. unguiculatus*, 6 *S. caecutiens*, and 11 *S. gracillimus* were captured from wind-shelter belts near the Teshio Experimental Forest of Hokkaido University, between 25 June and 27 August 1992, and between 9 and 26 August 1993.

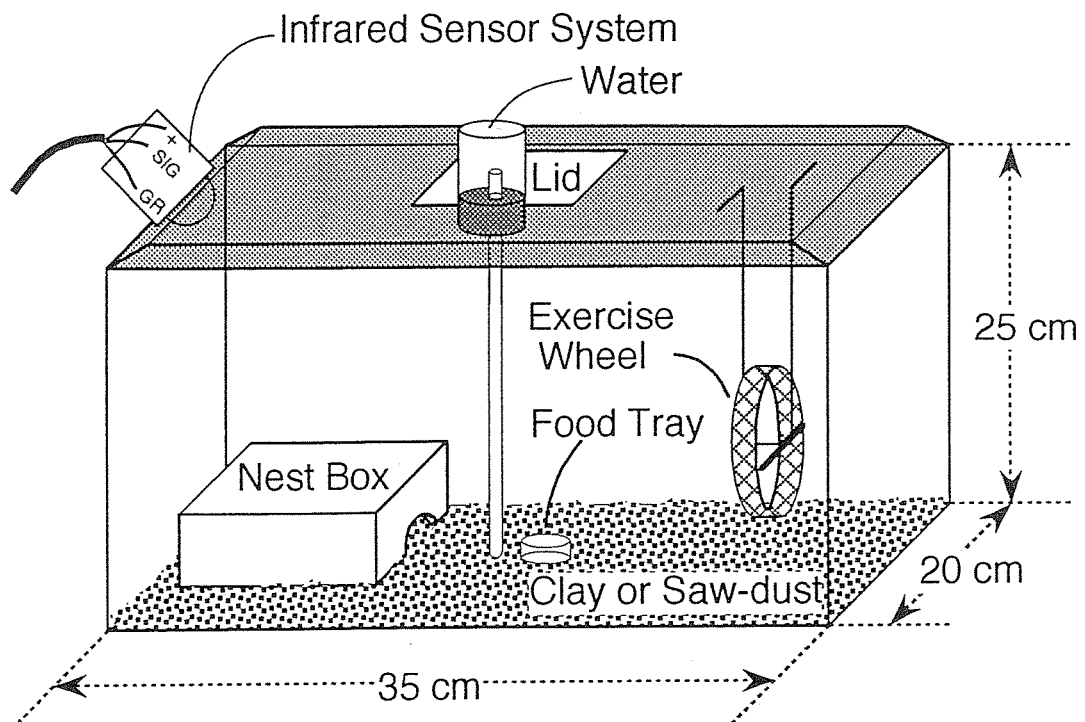

Fig. IV-1. A shrew cage used for the experiments. The diameter of the exercise wheel for *Sorex unguiculatus* and *S. caecutiens* was 10 cm and that for *S. gracillimus* was 7.5 cm. Infrared sensors were detached from the cages when experiments were not conducted.

Plastic pitfall traps (16-cm diameter and 24-cm deep) were used for capturing shrews. The trapping procedure was basically the same that described in Ohdachi (1992). The captive animals were kept individually in plastic cages (Fig. IV-1) under a 16-hr light and 8-hr dark photoperiodic cycle (16L8D) at 20 ± 2 °C (summer-simulated condition) on the Sapporo campus of Hokkaido University. The light intensity during the light period was 1420 lux and that during the dark period was 8 lux on the center of the laboratory floor. Shrew activity under the 16L8D & 20 °C regime was studied from August to November or December. Then, the photoperiod and

temperature conditions were adjusted to meet a regime of 10L14D & 5–15 °C (winter-simulated condition), and the shrew activity was studied until January.

Mixed paste diets were supplied every day. The ingredients of the paste were as follows in the proportions: 400 g pork meat, 800 g pork liver, 680 g canned tuna for cats (Mimy® tuna, Nihon Pet Food K.K., Tokyo), 430 g canned dog food (Vita-One® ration with dietary fibers, Nihon Pet Food K.K.), 100 g rabbit pellets (Eko Trading K.K., Nishinomiya, Hyogo) steeped in water, and vitamins. The mixture was put into ice cube trays and frozen, and the frozen cubic pastes were preserved in a freezer at -15 °C. Occasionally, some living earthworms (*Pheretima* sp.) and mealworms (*Tenebrio* sp.) or frozen silkworm pupae (*Bombyx mori*) were given in addition.

The device for measuring animal activity was fundamentally the same as used by Shirakawa & Oikawa (1988) and Honma *et al.* (1992). Pyroelectric infrared sensors (ELEKIT PS-393S, Kahomusen K.K., Fukuoka) were installed in the device. This sensor reacts to any movement of substances radiating light of 5–20 µm wavelengths. Ten sensors were connected to an 8-bit computer (NEC PC8801) and the activities of ten animals were measured simultaneously. The counts of reactions of each sensor were recorded every 15 minutes onto 1-MB floppy disk for four consecutive days. Because this device counts any movement of a shrew outside its nest box and because a shrew is usually resting or sleeping while it is in the nest box, the counts of the reactions by the

device represent a measure of the total activity of the shrew. The four-day session of measuring activity was repeated 1-6 times (usually five times) for each individual. For statistical analysis, one result (actograms of four consecutive days) arbitrarily chosen from the series of sessions for an individual was used as a representative of that individual's behavior.

Actograms of 10 *S. unguiculatus*, 10 *S. caecutiens*, and 10 *S. gracillimus* under the 16L8D & 20 °C regime, and those of 11 *S. unguiculatus*, 8 *S. caecutiens*, and 1 *S. gracillimus* under the 10L14D & 5–15 °C regime were obtained and used for analysis.

Results

The three species of shrews were fundamentally nocturnal. Most actograms revealed that shrews exhibited intensive active phases during the dark periods and persistent inactive phases during the light periods, in both of the two laboratory conditions (Figs. IV-2–4). Some actograms revealed, however, that the beginning and ending of intensive activity deviated greatly from the times of light on/off. Mean counts of activity per 15 minutes were obviously greater during the dark periods than during the light periods in all the three species under both experimental regimes (Table IV-1).

During the dark periods, completely inactive periods (the periods when no count was recorded for more than 15 minutes) were observed in each species (Figs. IV-2–4). The

S. unguiculatus

Type I (16L8D & 20°C)

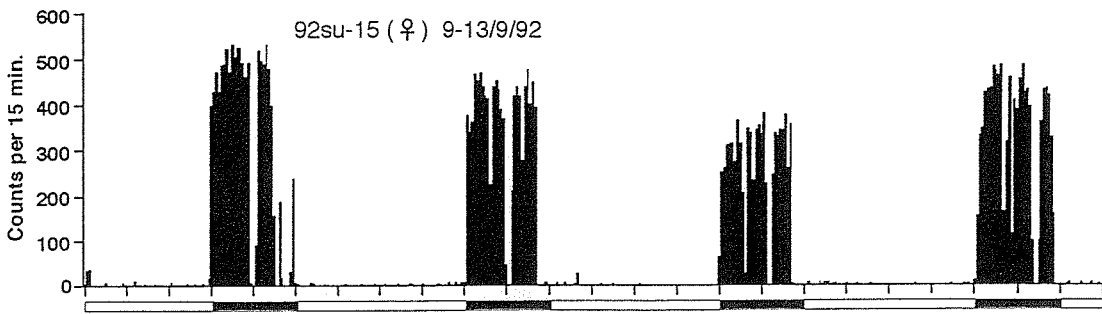

Type II (16L8D & 20°C)

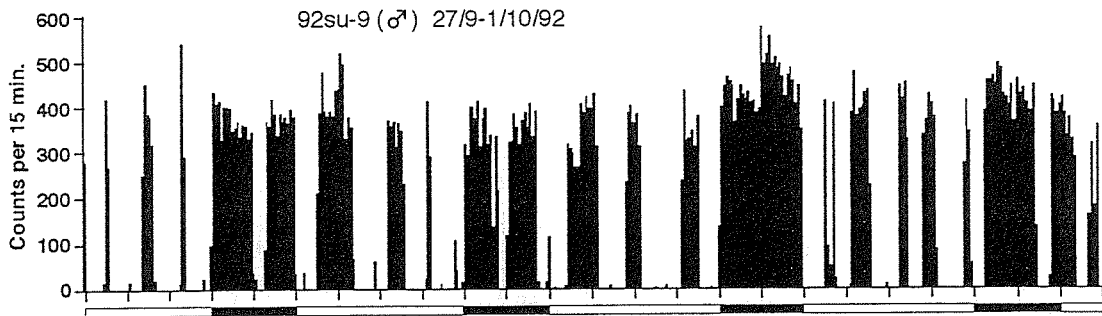

Type I (10L14D & 5-15°C)

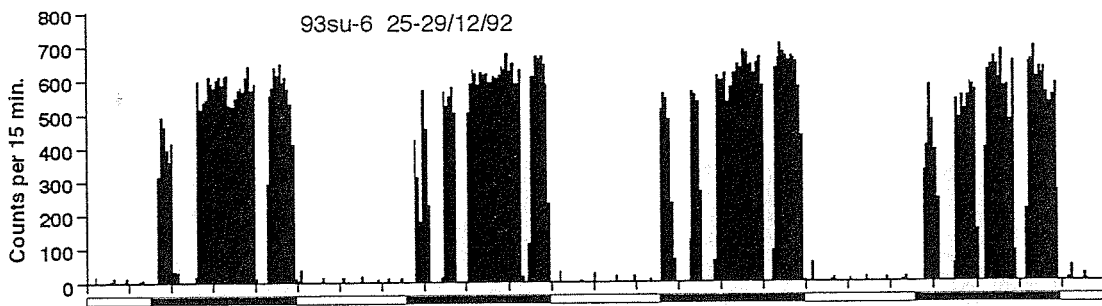

Type II (10L14D & 5-15°C)

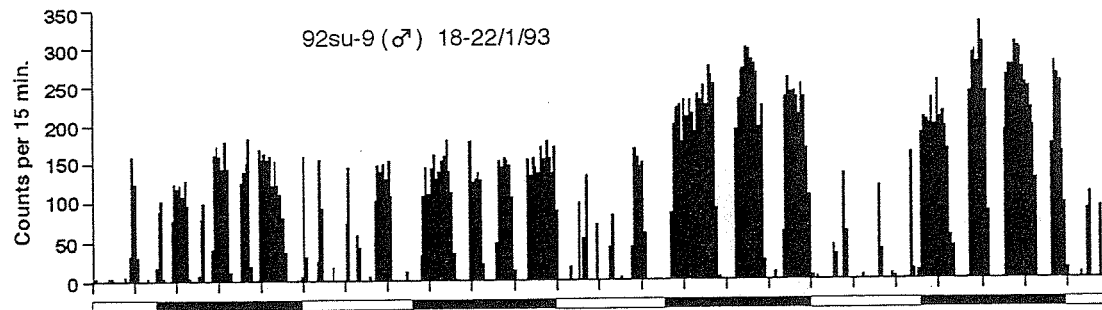
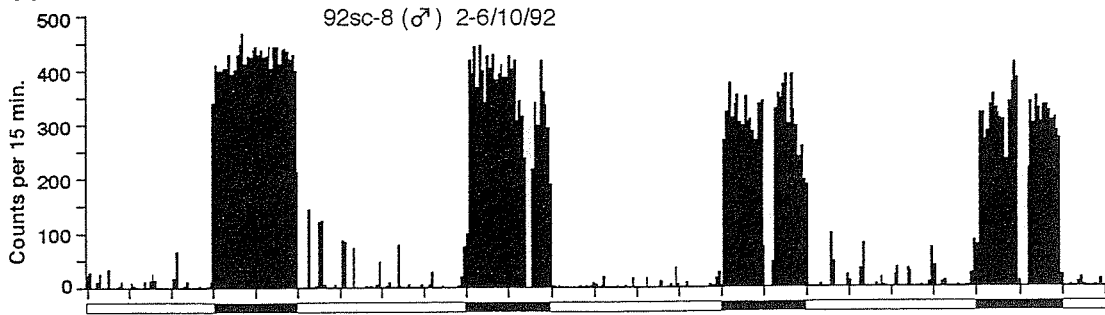

Fig. IV-2. Typical actograms of *Sorex unguiculatus* under the two experimental regimes. White and black bars indicate the light and dark periods, respectively. The unit of the time axis is 4 hours.

S. caecutiens

Type I (16L8D & 20°C)



Type II (16L8D & 20°C)

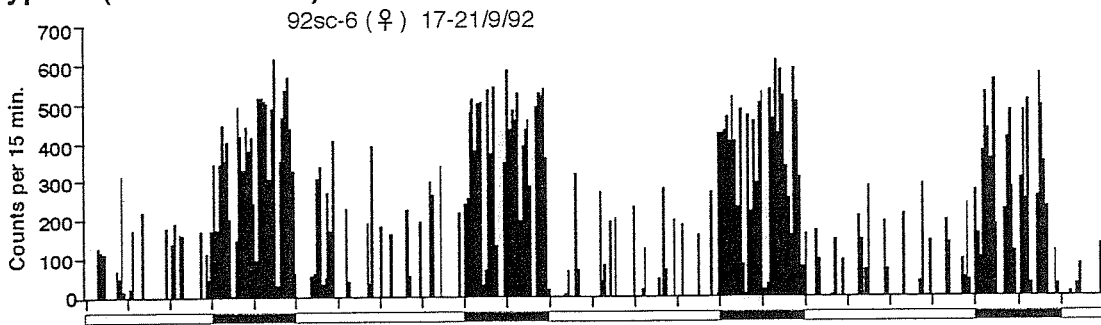

Type I (10L14D & 5-15°C)

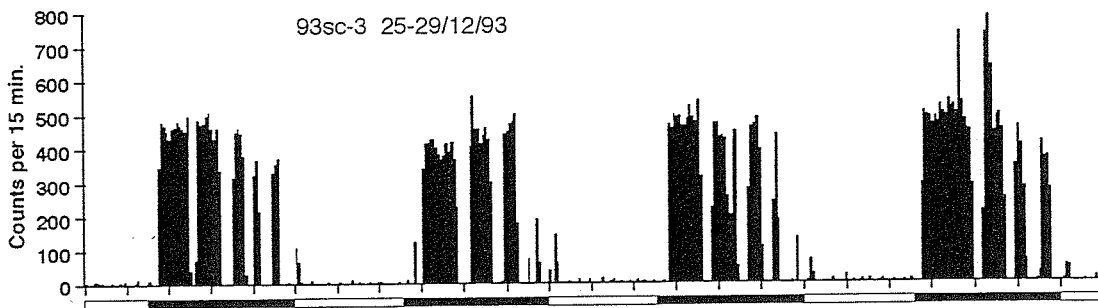

Type II (10L14D & 5-15°C)

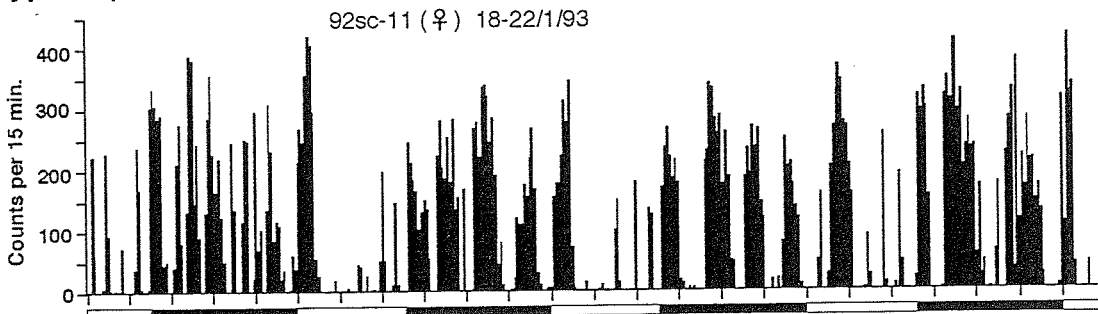
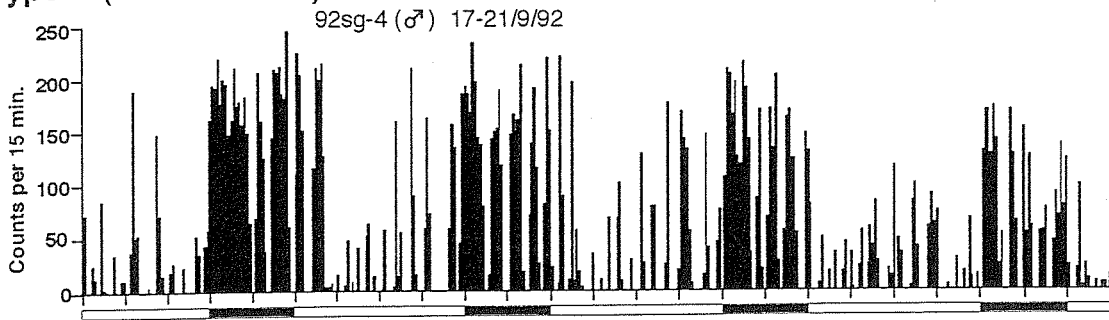

Fig. IV-3. Typical actograms of *Sorex caecutiens*. See Fig. IV-2 for explanations.

S. gracillimus

Type II (16L8D & 20°C)



Type I (10L14D & 5-15°C)

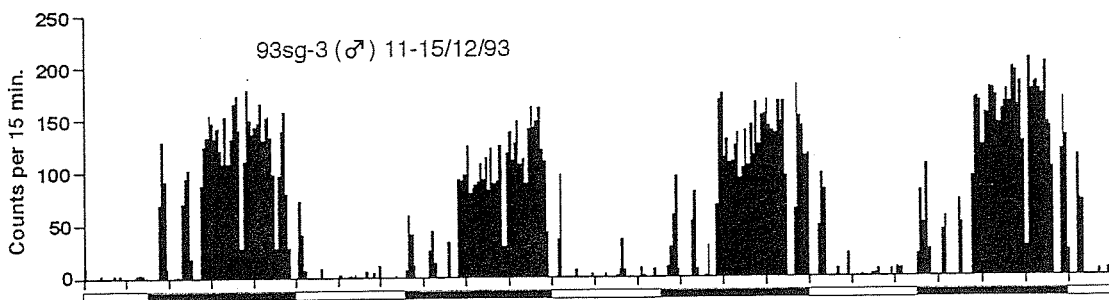

Fig. IV-4. Actograms of *Sorex gracillimus*. See Fig. IV-2 for explanations.

Table IV-1. Mean activity counts per 15 minutes (\pm S.D.) during light (L) and dark (D) periods and the mean total counts over 24 hours (\pm S.D.) under the 16L8D & 20 °C and 10L14D & 5-15 °C regimes in three species of shrews. Letters on the upper right of means indicate the result of Mann-Whitney's *U*-test (compare the values between the two experimental conditions within species); the same letters indicate non-significant difference ($\alpha = 0.05$).

		<i>S. unguiculatus</i>	<i>S. caecutiens</i>	<i>S. gracillimus</i>
16L8D & 20 °C				
Counts per 15 min.	L	13.3 ^a \pm 10.6	23.6 ^a \pm 16.9	26.0 \pm 15.7
	D	298.5 ^a \pm 76.3	287.1 ^a \pm 99.8	154.6 \pm 42.5
Total counts		10374.3 ^a \pm 2548.6 (n = 10)	10693.3 ^a \pm 3269.6 (n = 9)	6785.1 \pm 1616.1 (n = 9)
10L14D & 5-15 °C				
Counts per 15 min.	L	14.3 ^a \pm 13.9	36.7 ^a \pm 27.8	14.5
	D	145.8 ^b \pm 94.2	259.2 ^a \pm 112.2	80.4
Total counts		8738.0 ^a \pm 5163.2 (n = 10)	15984.4 ^a \pm 6588.7 (n = 8)	5083.3 (n = 1)

mean number of completely inactive periods per one dark period was smallest in *S. unguiculatus* and greatest in *S. gracillimus* under the 16L8D & 20 °C regime (Table IV-2). The mean duration of the completely inactive period was significantly shorter in *S. gracillimus* than in the other two species under the 16L8D & 20 °C regime. Under the 10L14D & 5–15 °C regime, the number of inactive periods did not differ significantly between *S. unguiculatus* and *S. caecutiens*, although the mean duration of inactivity was significantly longer in *S. unguiculatus* than in *S. caecutiens* (Table IV-2); *S. gracillimus* was omitted from this analysis, since results were obtained from only one individual.

Table IV-2. Mean numbers of completely inactive periods per dark period (\pm S.D.) and their mean duration (\pm S.D.) under the 16L8D & 20 °C and 10L14D & 5-15 °C regimes in three species of shrews. Numbers in brackets are the numbers of completely inactive periods per hour during the dark periods. Numbers in parentheses are those of samples averaged and individuals examined, respectively. Letters on the upper right of means indicate the result of Mann-Whitney's *U*-test (compare the values between species within laboratory condition, or between conditions within species); the same letters indicate non-significant difference ($\alpha=0.05$). When needed, the sequential Bonferroni correction was applied (Rice 1989).

		<i>S. unguiculatus</i>	<i>S. caecutiens</i>	<i>S. gracillimus</i>
16L8D & 20 °C	No. of inactive periods per dark period [per hr.]	1.00 ^a \pm 0.93 [0.13 ^a] (40, 10)	1.78 ^b \pm 1.25 [0.22 ^b] (36, 9)	3.00 ^c \pm 1.81 [0.38 ^c] (40, 10)
	Mean duration (min.)	33.5 ^a \pm 16.6 (51, 10)	33.8 ^a \pm 14.6 (64, 9)	24.7 ^b \pm 13.0 (119, 10)
10L14D & 5-15 °C	No. of inactive periods per dark period [per hr.]	5.58 ^d \pm 1.91 [0.40 ^d] (40, 10)	4.81 ^d \pm 1.86 [0.34 ^d] (36, 9)	3.50 \pm 0.58 [0.25] (4, 1)
	Mean duration (min.)	48.5 ^c \pm 20.1 (195, 10)	33.5 ^a \pm 14.8 (155, 8)	46.1 \pm 16.1 (14, 1)

During the light periods, completely inactive periods were frequently observed. The number of inactive periods per light period was constant among the species under the 16L8D & 20 °C regime, while it was significantly greater in *S. caecutiens* than in *S. unguiculatus* under the 10L14D & 5–15 °C regime (Table IV-3). The mean duration of the completely inactive period was significantly longer in *S. unguiculatus* than in the other two species under the 16L8D & 20 °C regime and was also greater in *S. unguiculatus* than in *S. caecutiens* under the 10L14D & 5–15 °C regime (Table IV-3).

Table IV-3. Mean numbers of completely inactive periods per light period (\pm S.D.) and their mean duration (\pm S.D.) under the 16L8D & 20 °C and 10L14D & 5-15 °C regimes in three species of shrews. See Table IV-2 for more explanations.

		<i>S. unguiculatus</i>	<i>S. caecutiens</i>	<i>S. gracillimus</i>
16L8D & 20 °C	No. of inactive periods per light period [per hr.]	11.37 ^a \pm 2.71 [0.71 ^a] (30, 10)	12.48 ^a \pm 3.11 [0.78 ^a] (27, 9)	12.17 ^a \pm 2.26 [0.76 ^a] (30, 10)
	Mean duration (min.)	57.5 ^a \pm 35.3 (342, 10)	46.1 ^b \pm 24.7 (337, 9)	44.3 ^{bc} \pm 29.8 (363, 10)
10L14D & 5-15 °C	No. of inactive periods per light period [per hr.]	7.47 ^b \pm 1.38 [0.74 ^a] (30, 10)	9.09 ^c \pm 1.98 [0.91 ^b] (27, 9)	7.67 \pm 1.16 [0.77] (4, 1)
	Mean duration (min.)	56.0 ^a \pm 27.2 (224, 10)	35.6 ^d \pm 16.4 (217, 8)	48.9 \pm 21.8 (23, 1)

The number of inactive periods per dark period increased from the 16L8D & 20 °C to 10L14D & 5–15 °C regimes for *S. unguiculatus* and *S. caecutiens* (Table IV-2), while the mean duration of the inactive period lengthened

only for the former species. Conversely, the number of inactive periods per light period decreased from the 16L8D & 20 °C to 10L14D & 5–15 °C regimes in *S. unguiculatus* and *S. caecutiens* (Table IV-3), and the mean duration shortened only in the latter species. The numbers of inactive periods per hour both during the dark and light periods tended to increase from the summer- to winter-simulated conditions in *S. unguiculatus* and *S. caecutiens* (Tables IV-2 and 3). The counts of reactions per 15 minutes during the dark periods decreased from the 16L8D & 20 °C to 10L14D & 5–15 °C regimes in *S. unguiculatus* (Table IV-1), but did not differ between the two conditions in *S. caecutiens*. Neither the counts per 15 minutes during the light period nor the total counts during 24 hours differed significantly between the two conditions in *S. unguiculatus* and *S. caecutiens* (Table IV-1).

Activity rhythm patterns were classified into two types (Figs. IV-2–4): Type I, activity was much less during the light periods than the during dark periods; Type II, short but intensive active phases were also observed during the light periods although the duration was obviously less than that during the dark periods. Usually, each individual showed the same type of activity pattern among different experimental sessions, but some individuals showed different types. If an individual showed different types among the sessions, the actogram type of the individual was determined so as to be proportional to the numbers of the sessions of each type. The ratios of Types I to II (I/II) were 8 individuals/2 individuals in *S. unguiculatus*, 6.5/3.5 in *S. caecutiens*, and 0/10 in *S.*

gracillimus under the 16L8D & 20 °C regime. Under the 10L14D & 5–15 °C regime, the ratios of the activity types were 9/2 in *S. unguiculatus*, 5.7/2.3 in *S. caecutiens*, and 1/0 in *S. gracillimus*.

Discussion

Many soricine species are known to be nocturnal or at least more active at night than during the day (Jánsky & Hanák 1960, Buckner 1964, Buchalczyk 1972, Genoud 1984), although there are some exceptions. *Neomys fodiens*, for example, does not show a clear difference in activity between night and day (Voesenek & Van Bommel 1984, Lardet 1988). In the present study, the three shrew species of Hokkaido were explicitly proven to be nocturnal, both in summer- and winter- simulated conditions (Figs. IV-2–4). Some soricids have been reported as having two peaks of activity at dawn and dusk (Crowcroft 1957, Jánsky & Hanák 1960). Such a bimodal activity pattern was observed only in *S. unguiculatus* under the 16L8D & 20 °C regime, whereas the activity patterns of this species under the 10L14D & 5–15 °C regime and of the other species were polymodal (Figs. IV-2–4 and Table IV-2).

Although Yoshino and Abe (1984) reported that *S. caecutiens* was more nocturnal than *S. unguiculatus*. However, such a tendency was not observed in the present study. On the contrary, *S. caecutiens* was more active during the light periods than *S. unguiculatus* (Table IV-1). Yoshino

and Abe (1984) were unable to observe shrew activity while they were under the ground. *S. unguiculatus*, however, frequently uses underground spaces even during the dark periods (see Chapter VI), and Yoshino and Abe (1984) seemed to underestimate the nocturnal activity of *S. unguiculatus*. Another cause for the inconsistency between Yoshino & Abe (1984) and the present study may be related to the types of cages used. In the present study, shrews were unable to make burrows, which might prevent their activity during the light periods.

The present study demonstrated clear differences in some features of activity pattern among the three shrew species. Such interspecific differences in activity pattern appear to be related to differences in body weight. *S. unguiculatus* is the heaviest (ca. 15 g for adult male), *S. caecutiens* is intermediate (ca. 7 g for adult male), and *S. gracillimus* is the lightest (ca. 4.5 g for adult male) (Ohdachi & Maekawa 1990). The ratios of actogram Types I/II and the ratios of activity counts per 15 minutes in dark/light periods decreased, and the mean numbers of inactive periods increased in the decreasing order of shrews' body weight under the 16L8D & 20 °C regime. It is well known that small shrew species have higher basal metabolic rates per unit weight than large ones (e.g., Buckner 1964, Hanski 1984, Aitchison 1987, Genoud 1988, McNab 1991). The metabolic rate is expected to be highest in *S. gracillimus*, intermediate in *S. caecutiens*, and lowest in *S. unguiculatus*. It is plausible that species with higher metabolic rates must repeat more

frequently the cycle of active/resting than those with lower metabolic rates.

When laboratory conditions were changed from the summer- to winter-simulated regimes, the numbers of resting periods per hour during the dark periods and/or the mean duration of inactive periods increased in both *S. unguiculatus* and *S. caecutiens* (Table III-2). On the other hand, the total activity counts over 24 hours did not differ between the two conditions. Therefore, these shrews might conserve energy by taking more rest during nights (= active period) in winter than in summer.

Chapter V

Burrowing Habits and Earthworm Preferences

Abstract

Burrowing habits and preferences for earthworms as food were examined in laboratory for 10 *S. unguiculatus*, 10 *S. caecutiens*, and 6 *S. gracillimus*. Most *S. unguiculatus* ate silkworm pupae placed 15-cm under the ground and constructed tunnel systems. Although *S. caecutiens* and *S. gracillimus* could made simple holes, they could not made tunnel systems and did not eat silkworm pupae buried under the ground. *S. unguiculatus* preferred earthworms, while *S. caecutiens* and *S. gracillimus* hesitated to eat them and some of the former species and most of the latter did not eat them at all.

Introduction

In Chapter III, it was demonstrated that main prey of *S. unguiculatus* was earthworms and that of *S. caecutiens* and *S. gracillimus* was small epigeal arthropods. This finding suggests that *S. unguiculatus* be an underground forager and *S. caecutiens* and *S. gracillimus* have epigeal habits. To detect interspecific interactions for food and space among them, it is necessary to compare burrowing ability and potential use of earthworms, which are principal diet of *S. unguiculatus* and an abundant underground food resource (Aoki 1973). Yoshino and Abe (1984) investigated the burrowing habits of *Sorex unguiculatus* and *S. caecutiens*. They revealed that *S. unguiculatus* made burrows down to 30 cm and frequently

used underground foods, while *S. caecutiens* made only superficial burrows and did not take food in deep soil. However, the burrowing habit of *S. gracillimus* and potential earthworm use of the three soricids have not been studied. In this chapter, I compare burrowing habits and preferences for earthworms as food among *S. unguiculatus*, *S. caecutiens*, and *S. gracillimus*.

Materials and methods

Ten *S. unguiculatus*, 10 *S. caecutiens*, and 6 *S. gracillimus*, which were captured in Yufutsu Moor (Tomakomai) between 14–18 June 1992 and in a wind-shelter belt near the Teshio Experimental Forest of Hokkaido University (Horonobe) between 25 June and 27 August 1992, were used for experiments. The trapping procedure was basically the same as described by Ohdachi (1992). Captured animals were kept individually in plastic cages (see Fig. IV-1) under a "16-hr light, 8-hr dark" photoperiodic cycle at 20 ± 2 °C. Mixed paste diet was supplied every day. The diet was made of pork meat, pork liver, canned tuna, dog chum, and pellets for rabbits (see Chapter IV). Experiments were conducted from 4 October to 6 December 1992.

The burrowing habits of the shrews were examined as follows: a frozen silkworm pupa (*Bombyx mori*) was placed at each of the four bottom corners of a plastic cage, and then 15-cm deep layer of soil was put into the cage. The soil hardness was approximately 1.5 kg/cm². A wooden nest box lacking

base floor was placed on the center of the soil surface, and trays of the mixed paste and water were placed on the nest box. A shrew was introduced into the experimental cage during the light period (about 2 hours after the light was put on). Approximately 24 hours later, the shrew was removed from the experimental cage. Then, it was examined whether the shrew made simple vertical holes, a tunnel system (complex burrows with more than two entrances and/or horizontal burrows), or neither of them and whether the silkworm pupae at the bottom corners were eaten. Preliminary observations showed that all the three species preferred the silkworm pupae to the mixed pastes.

The earthworm preferences of the shrews were examined as follows: a living earthworm (*Pheretima* sp.) was cut into small fragments (ca. 0.1–0.6 g) and a fragment was put into an empty plastic cage with the mixed paste diet. Then, a shrew was introduced into the experimental cage and its behavior was observed either until the entire earthworm fragment was eaten, or until one hour had passed. When a shrew ate at least more than half of the earthworm fragment, I considered that the shrew 'ate' earthworms. For most individuals of *S. caecutiens* and *S. gracillimus*, experiments were replicated twice, but experiments were not replicated for *S. unguiculatus*. When an individual showed different results between the two replications, 0.5 was given to each category.

Results and discussion

Most *S. unguiculatus* ate the silkworm pupae buried 15 cm under the soil surface, whereas the other two species never ate them (Table V-1). Six out of 8 *S. unguiculatus* constructed tunnel systems, while neither *S. caecutiens* nor *S. gracillimus* created tunnel systems although some of them made simple holes (Table V-1). Additional observations revealed that one *S. caecutiens* constructed a crude tunnel system when it was kept in a large cage (65 cm L X 30 cm W X 38 cm H, see Chapter VI) with soil (12-cm deep) for more than 4 days, but no *S. gracillimus* constructed tunnels even if kept in the large cages for more than 5 days. Thus, *S. unguiculatus* was highest in burrowing ability and *S. gracillimus* the lowest, while *S. caecutiens* was intermediate.

Table V-1. Burrowing habits of three *Sorex* species. *S. u.*, *S. unguiculatus*; *S. c.*, *S. caecutiens*; *S. g.*, *S. gracillimus*.

	<i>S. u.</i>	<i>S. c.</i>	<i>S. g.</i>
No. of shrews examined	8	9	5
No. of shrews which ate pupae in soil ^a	7	0	0
No. of shrews which made tunnel systems	6	0	0
No. of shrews which made simple holes ^b	2 (8.0 cm) ^c	6 (3.2 cm)	2 (5.5 cm)

^aThe number of the shrews which ate at least one out of the four silkworm pupae placed at the bottom corners (15-cm under the soil surface) of a cage.

^bExcept for the shrews which made tunnel systems.

^cMean maximum depth of observed holes.

The interspecific differences in burrowing ability appear to be related to morphology. *S. unguiculatus* has relatively large forefeet with long claws to its body size, while the other two species have relatively small forefeet with short claws (Abe 1967). In addition, body weights are the greatest in *S. unguiculatus*, intermediate in *S. caecutiens*, and smallest in *S. gracillimus* (Ohdachi & Maekawa 1990). It is plausible that large forefeet with long claws are good digging tools and that a large body size guarantees a robust muscle system for the forelimbs and supplies sufficient energy for digging.

Table V-2. Earthworm preferences of three *Sorex* species.

	No. of shrews which ate earthworms ^a	No. of shrews which did not eat earthworms ^b
<i>S. unguiculatus</i>	10	0
<i>S. caecutiens</i>	6.5	3.5
<i>S. gracillimus</i>	1	5

^{a,b}The numbers of shrews which either ate and did not eat a fragment of earthworm within one hour. When an individual showed different results between two replications of experiment, 0.5 was given to each category.

All *S. unguiculatus* ate earthworms (*Pheretima* sp.) while some *S. caecutiens* and most *S. gracillimus* did not eat them (Table V-2). This result was consistent with the diets of wild-caught shrews (Chapter III): *S. unguiculatus* was a heavy consumer of earthworms, *S. caecutiens* rarely consumed them, and *S. gracillimus* did not eat them at all. Furthermore, all *S. unguiculatus* ate the entire earthworm fragment within a few

minutes. An additional experiment demonstrated that *S. unguiculatus* even attacked whole living earthworms (ca. 1–2 g) immediately after the earthworm was introduced to shrews and ate them within a few minutes (see also, Yokohata 1990). In contrast, *S. caecutiens* and *S. gracillimus* hesitated to eat the earthworm fragments, although they frequently smelled them.

Earthworms seem to be an unsuitable food item for *S. caecutiens* and *S. gracillimus*, since their gape and body sizes are too small to handle a large animated earthworm. However, handling efficiency does not fully explain the disfavor of earthworms in *S. caecutiens* and *S. gracillimus*, because earthworms were cut into small fragments in the present experiment so that even small shrew species could deal easily with them. The smell or chemical substances might provoke the disfavor against earthworms in these species.

It may be worthy to note the following anecdote. Another kind of earthworm (*Eisenia foetida*) was also used in an additional experiment, instead of *Pheretima* sp. However, *S. caecutiens* and *S. gracillimus* did not eat *Eisenia foetida* and even *S. unguiculatus* hesitated to eat it.

Low or no consumption of earthworms by *S. caecutiens* and *S. gracillimus* in the field (Chapter III) was presumably not caused by interference from *S. unguiculatus*, but was related with inborn preference to earthworms. Thus, there would be little competition for earthworms between *S. unguiculatus* and *S. caecutiens* or *S. gracillimus*.

Chapter VI

Laboratory Experiments of Spatial Use and Aggression

Abstract

Aggressions and effects of the presence of con- or hetero-specific individual on space use (vertical and horizontal) were investigated in laboratory for *Sorex unguiculatus*, *S. caecutiens*, and *S. gracillimus*. *S. unguiculatus* frequently used the strata below the surface floor of experimental cage or subterranean burrows as its activity space, while *S. caecutiens* and *S. gracillimus* mainly used the surface floor or the ground surface. The presence of another individual changed neither patterns of space use nor behavioral patterns (active/inactive and underground/resting/moving on the ground surface) in the three shrew species. When two individuals were put together into two interconnected cages, shrews stayed in different cages, except for *S. gracillimus* with conspecific individual; however, the proportion of occupying the same and different cages did not differ significantly in spite of the difference in species put together. *S. unguiculatus* was the strongest, *S. caecutiens* was intermediate, and *S. gracillimus* was the weakest in terms of physical superiority. *S. caecutiens* attacked *S. gracillimus* most frequently and *S. gracillimus* received attacks from *S. caecutiens* most frequently. Interspecific differences in space use and aggressive behavior might partially explain the differences in relative abundance of the three soricids in Hokkaido.

Introduction

Interspecific competition in the small mammal guilds which consist of differently sized species is usually asymmetrical, favoring the larger species (Schoener 1983, Persson 1985). It is also reported that in some guilds of small insectivorous mammals, larger species are physically stronger than the smaller, and competitive effects from smaller species seem to be negligible (Churchfield 1984, 1991, Dickman 1986, 1988, 1991, Ellenbroek 1990, Ellenbroek & Hamburger 1991). In some of these guilds, it has been confirmed that competition is of interference type rather than exploitative (Dickman 1988, 1991), and that physical superiority determines the outcome of competition. In such a guild, it is necessary to investigate the effects of interference of other species on behaviors like space use and aggressive interactions among guild members to understand the community structure and the mechanism of coexistence.

Modification of space use and behaviors in the presence of other individuals may affect the consequence of competition. For instance, if two species are under interference competition and neither of them changes space use or behaviors, the physically superior species may exclude the inferior one from the habitat (Hardin 1960, Schoener 1975, Werner & Hall 1976, Holbrook 1979, Alatalo & Moreno 1987, Arthur 1987). In this case, aggressive behavior and

physical superiority are essential keys to determine the outcome of competition.

Sorex unguiculatus, *S. caecutiens*, and *S. gracillimus* are common and distributed throughout Hokkaido; however, the latter two species did not occur together as the relatively most and second most abundant species (Chapter II). It was also confirmed in Chapter III that dietary constituents were more similar between *S. caecutiens* and *S. gracillimus* than between either of them and *S. unguiculatus*. These findings suggest that interspecific competition be more severe between *S. caecutiens* and *S. gracillimus*. Further, *S. unguiculatus* had high burrowing ability, while the other two species were poor borrowers (Chapters III and V). Therefore, it is suspected that space use is also similar between *S. caecutiens* and *S. gracillimus*, and that a strong interference for space exists between them.

In cryptic animals whose life history is little known, such as soricids in Hokkaido, extensive field studies of space use and interactions among individuals are very difficult to be carried out. Ohdachi (1992) reported the relation of home ranges among sympatric shrews in Hokkaido, but he could present only insufficient information to discuss interspecific competition because it was difficult to collect data about direct interactions among shrews. An alternative way to investigate direct spatial interactions is to conduct laboratory experiments. Although there are some problems, such as reality of simulated situations and scaling, the results obtained from laboratory experiments would complement

those from field studies (Diamond 1986, Keddy 1989, Ellenbroek 1990).

In this chapter, I investigate whether the presence of another individual affects space use and behaviors, as well as aggressions in *S. unguiculatus*, *S. caecutiens*, and *S. gracillimus* by two laboratory experiments. Then, I relate the results to findings from the other chapters.

Materials and methods

Experiment 1

Experiment 1 was designed to examine the effects of the presence of con- or hetero-specific individual on vertical space use of shrews. Nine *Sorex unguiculatus* (5 young males, 4 young females), 8 *S. caecutiens* (1 adult male, 4 young males, 3 young females), and 5 *S. gracillimus* (3 young males, 2 young females), which were captured in Yufutsu Moor (Tomakomai) during 14–18 June 1992 and in a wind-shelter belt near Teshio Experimental Forest of Hokkaido University (Horonobe) during 25 June to 27 August 1992, were used for this experiment. Method of rearing shrews was given in section of materials and methods of Chapter IV. Shrews were reared under a 16-hr light and 8-hr dark photoperiodic cycle at 20 ± 2 °C. Experiments were conducted throughout the dark period from 11 October 1992 to 6 January 1993.

Observation cages shown in Fig. VI-1 were constructed for this experiment. A cage had 20 strata and the surface

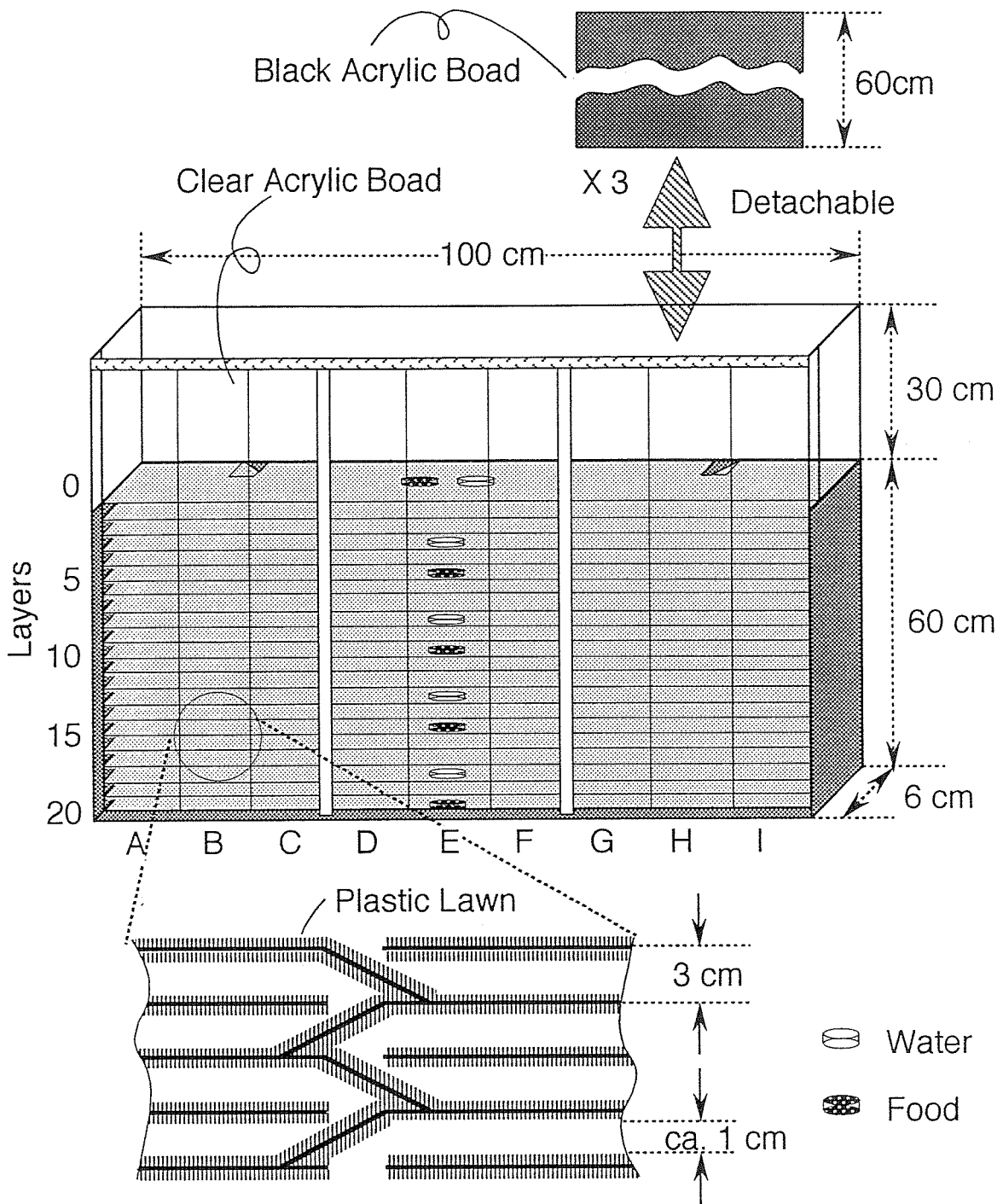

Fig. VI-1. The experimental device for experiment 1. Black boads were removed just before an experiment.

floor with two stair lines. Each side of layer boards was covered with plastic lawns so that back and abdomen of a shrew could always touch plastic lawns when it was between the boards. Some pieces of tissue paper, which imitated fallen leaves, were put on the surface floor. Trays of the mixed paste diet and water were located as shown in Fig. VI-1. Black acrylic boards were attached in front of clear boards to exclude light before observation. Thirty minutes before the beginning of the dark period, an animal or two animals were simultaneously introduced on the surface floor of the cage. The black boards were removed gently immediately after the light was put off. Locations and behaviors of shrews were recorded every 15 minutes under weak red spot light during the dark period. For analysis, vertical location of a shrew was divided into 5 strata: surface (0), 1-5, 6-10, 11-15, and 16-20 strata. After an experiment session was finished, animals were removed and the cage was washed with ethanol and kitchen detergent and dried out. When two animals were put together in the cage, the physical dominance order was determined as follows: an animal was a "loser" if it escaped from the opponent when two animals encountered or fought, and the opponent was a "winner". If the observed times of "win" and "lose" were the same, the two animals were regarded as "even". When no direct contact was observed, it was classified into "no match". Results of 70 experimental sessions were used for analysis.

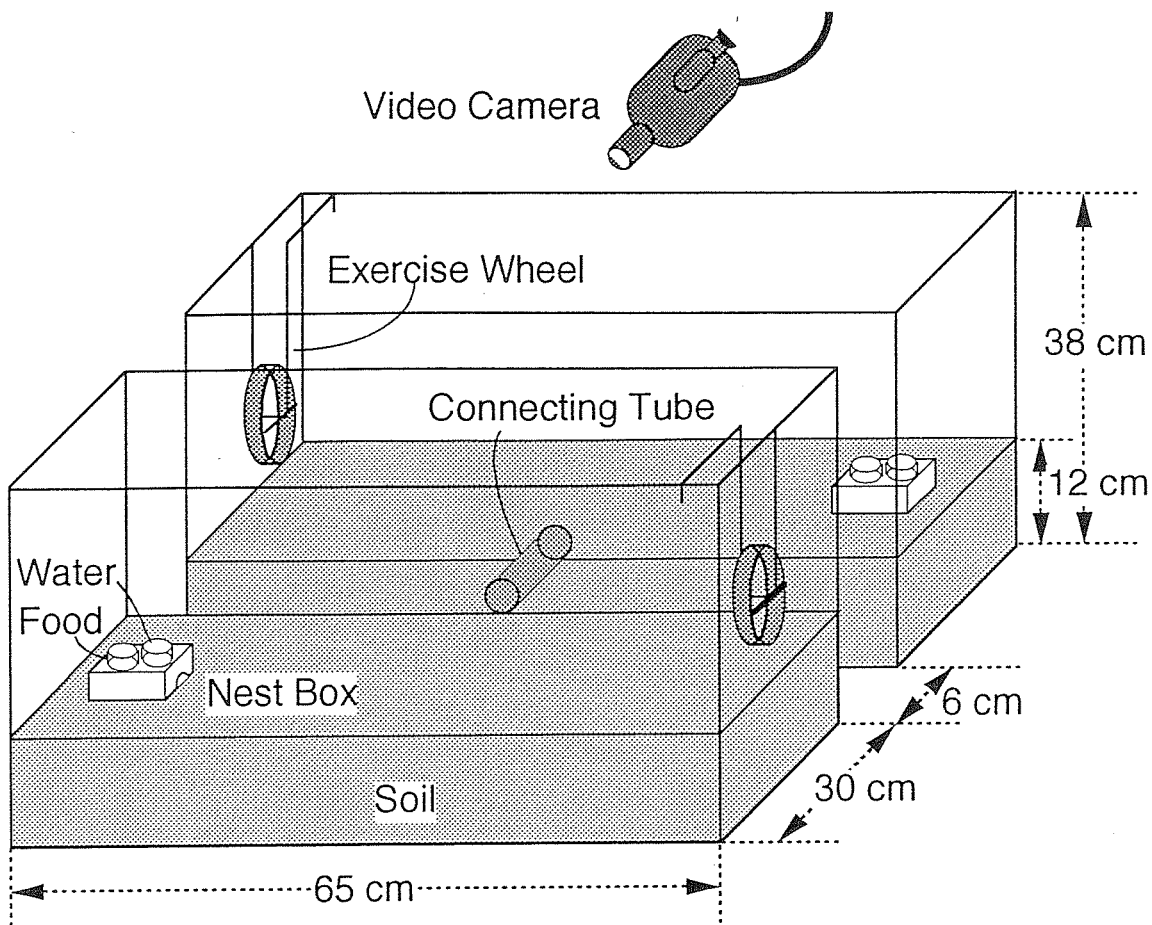

Fig. VI-2. The experimental device for experiment 2.

Experiment 2

Experiment 2 was designed to investigate aggressive behaviors and the effects of con- or hetero-specific individual on horizontal space use and behavioral patterns. Ten *S. unguiculatus* (1 adult female, 4 young males, 4 young females, 1 sex-unknown juvenile), 3 *S. caecutiens* (1 young male and 2 sex-unknown juvenile), and 5 *S. gracillimus* (2 adult females, 1 young male, and 2 young females), which were captured in wind-shelter belts near the Teshio Experimental Forest of

Hokkaido University during 6–22 August 1993, and 1 adult female *S. caecutiens* that was captured in Yufutsu Moor in July 1992, were used for this experiment. Methods of rearing shrews were given in the section of materials and methods of Chapter IV. Shrews were kept under a 16-hr light and 8-hr dark photoperiodic cycle at 20 ± 2 °C. Experiments were conducted throughout the dark period, from August 30 to November 24 1993. Light intensity during the light period was 1420 lux and that during the dark period was 12 lux on the floor at the center of laboratory.

Experimental cages shown in Fig. VI-2 were used for this experiments (note that the bottom of a nest box was open to the ground surface). Two animals were separately introduced into cages one day before an experiment, with both sides of the connecting tube being closed by rubber plugs. The rubber plugs were, then, removed 5 minutes before the dark period began. Behavior of shrews was recorded by a video camera recorder throughout the dark period (8 hours), using the twilight mode. As a control experiment, an empty cage was connected with a cage where a shrew was introduced. A cage in which a shrew was kept until two experimental cages were connected was called a "home" cage, and the other was called an "away" cage.

Behaviors of shrews were scanned every 5 minutes by replaying video tapes. Behaviors were categorized into three: "underground & digging" (shrews were underground or digging soil), "in nest box & resting" (shrews were in nest boxes or resting on the ground surface), and "walking,

running & whirling" (shrews were walking or running on the ground surface, or whirling exercise wheels). Underground and within nest box behaviors could not be observed in the present experiment. According to preliminary observations, a shrew was usually inactive while it was in nest box. Other kinds of behavior, such as eating, drinking, or self-grooming, were also observed, but the duration of them was usually too short to be scanned by the 5-minute interval observation. For *S. unguiculatus*, "underground & digging" and "in nest box & resting" were not precisely distinguished from each other, because this species usually constructed burrows in its "home" cage and some entrances of them were opened under nest box. According to preliminary observations, *S. unguiculatus* was usually under the ground instead of staying on the ground surface within nest box. Therefore, I referred the case where *S. unguiculatus* was in nest box with entrances of burrows as "underground & digging", unless I could verify that a shrew did not enter burrows. On the other hand, I referred the case where *S. caecutiens* or *S. gracillimus* was in nest box of *S. unguiculatus* as "in nest box & resting" except for the case in which it obviously entered burrows under nest box. Preliminary observations revealed that *S. caecutiens* and *S. gracillimus* usually stayed on the ground surface under nest box of *S. unguiculatus*. Sixty-two experimental sessions (496-hour observation in total) were used for analysis.

The number of attacks and the dominance order were determined by continuous observation of video tape throughout each experimental session (8 hours). Attacking

behavior included chasing, biting body or tail, and wrestling. When attacking behavior interrupted for more than 10 seconds, it was divided into separate attacks. The criteria of "win", "lose", and "no match" were the same as in Experiment 1. However, "even" was defined in this experiment as following case: frequent counterattacks were observed and an individual did not escape from the opponent even if the opponent often attacked it.

Results

Experiment 1

The percentages of active and non-active phases did not differ significantly between the experimental treatments (alone and with con- or hetero-specific individual) in the three species (Table VI-1). Interspecific differences in the percents of active/non-active phases were, however, significant ($P < 0.05$): *S. caecutiens* was most active, *S. gracillimus* was medium, and *S. unguiculatus* was least active. Dominance relations (win, even, lose, or no match) also did not affect activities of shrews (Table VI-2).

S. caecutiens used the surface (0) stratum significantly ($P < 0.05$) more frequently than *S. unguiculatus* when shrews were active, but utilization of the other strata did not differ significantly between the two species (Fig. VI-3). The surface activity differed significantly neither between *S. caecutiens*

Table VI-1. Mean percentages of "active" (\pm S.D.) and "rest & sleep" phases in shrews observed in Experiment 1 (see text for details of the experimental treatments). Letters in "alone" column indicate the result of ANOVA (arcsine transformation, Scheffe's method) between species. The same letters indicate non-significant difference ($\alpha=0.05$); in the present case all the differences were significant. The mean percentages did not differ significantly between the experimental treatments in the three species. (N), number of individuals examined.

Experimental treatment	Alone	with <i>S. u.</i>	with <i>S. c.</i>	with <i>S. g.</i>
<i>S. unguiculatus</i>	a			
Active	33.0 \pm 10.9	38.7 \pm 15.5	39.2 \pm 12.8	41.4 \pm 17.1
Rest & Sleep	67.0	61.3	60.8	58.6
(N)	(8)	(8)	(8)	(9)
<i>S. caecutiens</i>	b			
Active	70.6 \pm 12.1	73.3 \pm 17.9	65.5 \pm 25.0	68.6 \pm 8.2
Rest & Sleep	29.4	26.7	34.5	31.4
(N)	(7)	(8)	(8)	(8)
<i>S. gracillimus</i>	c			
Active	50.0 \pm 10.4	60.5 \pm 12.4	50.8 \pm 6.2	53.8 \pm 12.2
Rest & Sleep	50.0	39.5	49.2	44.2
(N)	(4)	(4)	(4)	(5)

Table VI-2. Mean percentage of "active" (\pm S.D.) and "rest & sleep" phases in shrews for different dominance relations. The mean percentages did not differ significantly between the dominance relations in the three species ($\alpha=0.05$, ANOVA, arcsine transformation, Scheffe's method). (N), number of individuals examined.

Dominance relation	Winner	Even	Loser	No match
<i>S. unguiculatus</i>				
Active	41.5 \pm 16.0	46.1 \pm 11.4	33.8 \pm 12.9	40.0 \pm 15.1
Rest & Sleep	58.5	53.9	66.2	60.0
(N)	(8)	(5)	(3)	(5)
<i>S. caecutiens</i>				
Active	56.8 \pm 19.4	70.5 \pm 17.8	77.2 \pm 16.7	75.8 \pm 12.6
Rest & Sleep	43.2	29.5	22.8	24.2
(N)	(6)	(7)	(7)	(4)
<i>S. gracillimus</i>				
Active	54.5 \pm 18.2	58.0 \pm 16.5	53.2 \pm 10.4	59.3 \pm 14.2
Rest & Sleep	45.5	42.0	46.8	40.7
(N)	(3)	(4)	(4)	(3)

A. *S. unguiculatus*

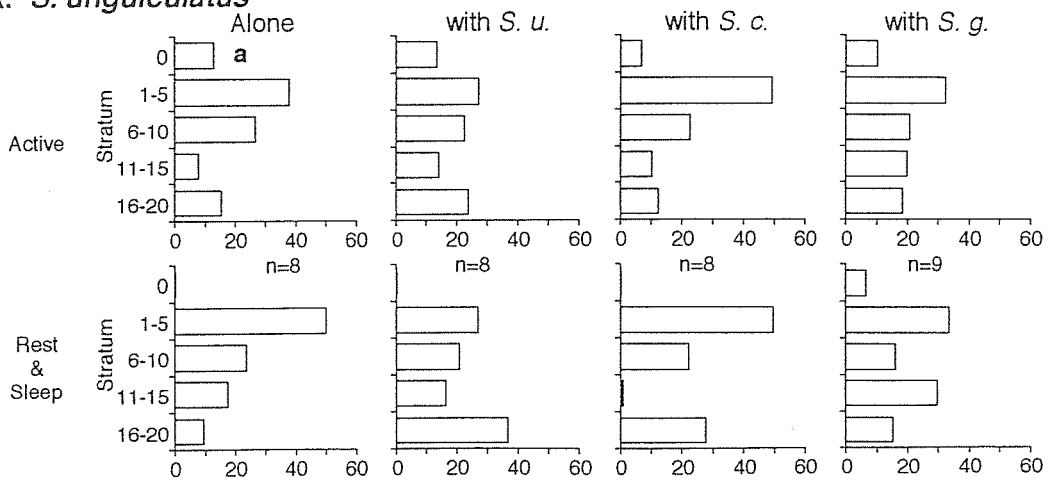

B. *S. cautiens*

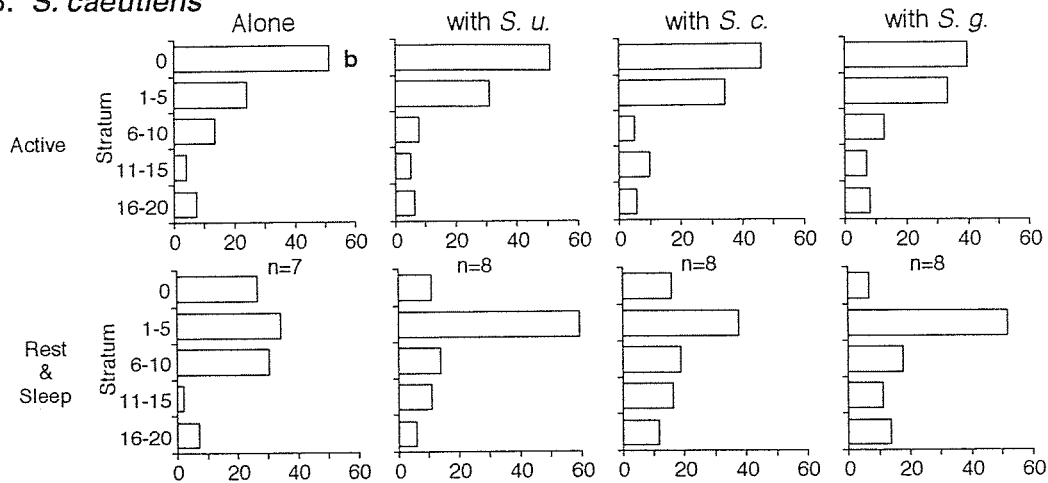

C. *S. gracillimus*

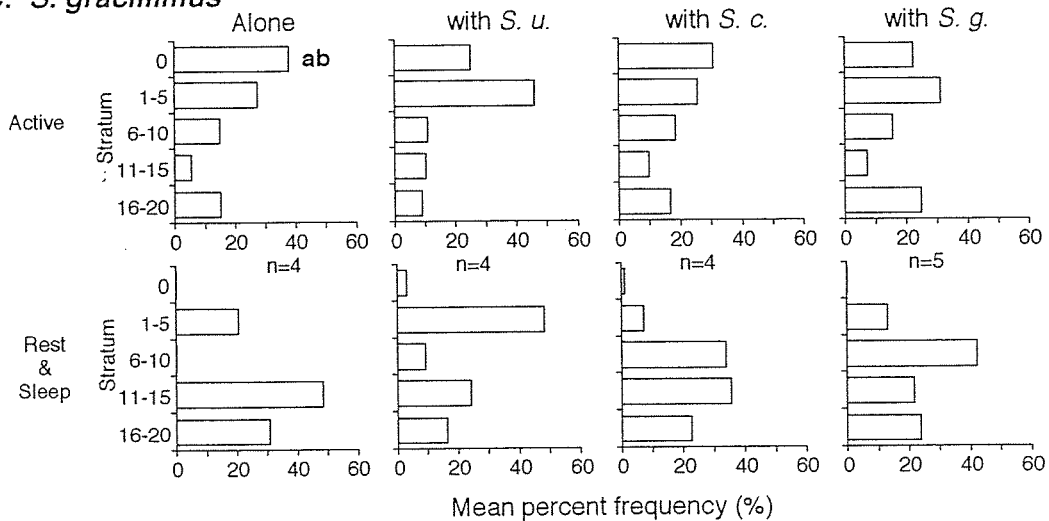
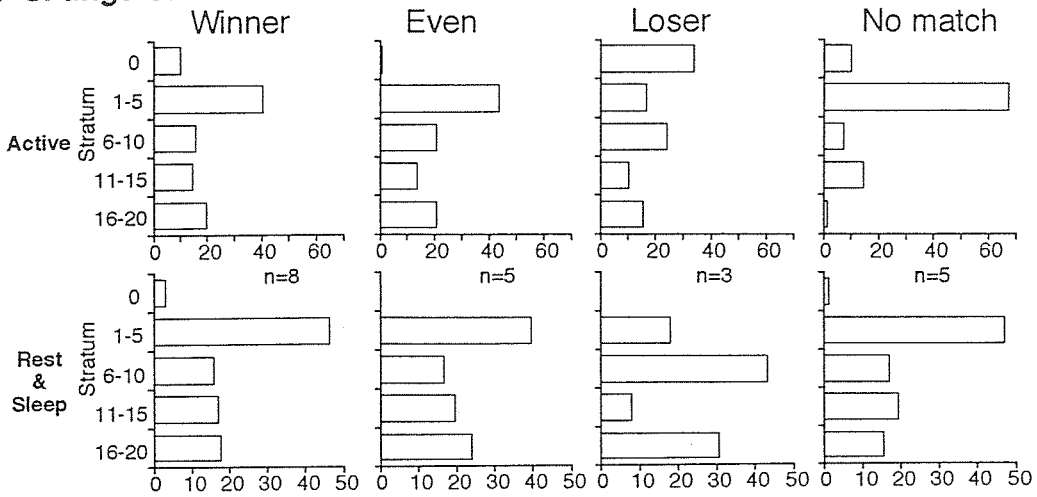
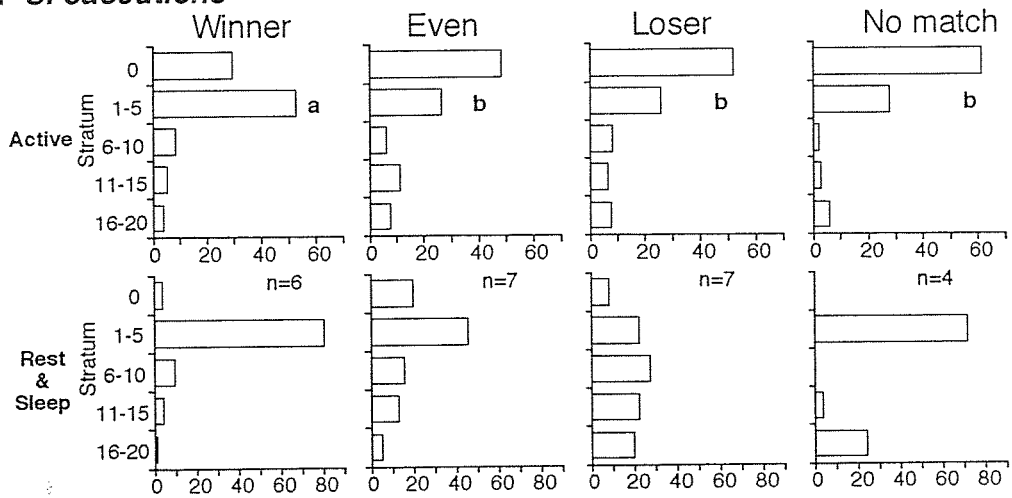

Fig. VI-3. Vertical space use of shrews when they were alone and with con- or hetero-specific individual. The same letters indicate non-significant difference in mean percent frequency for the surface (0) stratum between species when shrews were alone ($\alpha=0.05$, ANOVA, arcsine transformation, Scheffe's method, the sequential Bonferroni correction among strata). There was significant difference neither between species for the other strata when alone nor between experimental treatments for each stratum in the three species.

A. *S. unguiculatus*



B. *S. caecutiens*



C. *S. gracillimus*

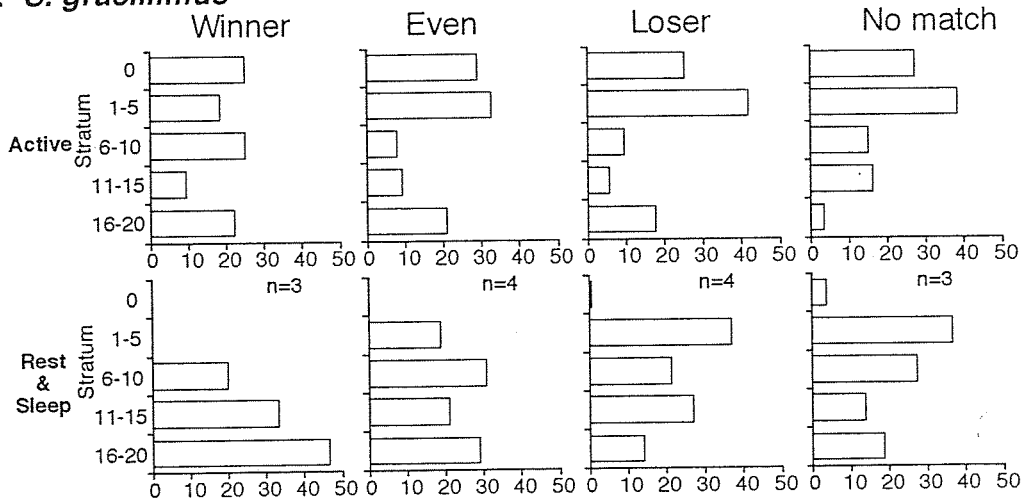

Mean percent frequency (%)

Fig. VI-4. Vertical space use of shrews for each category of dominance relation. The same letters indicate non-significant difference in mean percent frequency of 1-5 stratum between the categories of the dominance relations for *S. caecutiens* in active phase ($\alpha=0.05$, AVOVA, arcsine transformation, Scheffe's method, the sequential Bonferroni correction). The other strata did not differ significantly between the categories of dominance relation in the three species.

and *S. gracillimus* nor between *S. gracillimus* and *S. unguiculatus* (Fig. VI-3).

Vertical space use did not differ significantly between the experimental treatments in the three species (Fig. VI-3). The dominance relation did not affect the vertical space use in *S. unguiculatus* and *S. gracillimus*, too. *S. caecutiens* in active phase used the 1-5 stratum significantly more frequently when it was "winner" than when it was in the other dominance relations (Fig VI-4).

Table VI-3. Mean percentages of the utilization of "home" (\pm S.D.) or "away" cage by shrews observed in Experiment 2 (see text for details of the experimental treatments). The mean percentages differed significantly neither between the experimental treatments within species nor between species when shrews were 'alone' ($\alpha=0.05$, ANOVA, arcsine transformation, Scheffe's method). (N), number of individuals examined.

Experimental treatments	Alone	with <i>S. u.</i>	with <i>S. c.</i>	with <i>S. g.</i>
<i>S. unguiculatus</i>				
Home	70.7 \pm 28.3	76.9 \pm 20.5	64.2 \pm 36.5	72.1 \pm 29.1
Away	29.3	23.1	35.8	27.9
(N)	(10)	(10)	(10)	(10)
<i>S. caecutiens</i>				
Home	50.7 \pm 31.9	52.0 \pm 26.6	36.3 \pm 11.6	49.6 \pm 23.2
Away	49.3	48.0	63.7	50.4
(N)	(4)	(4)	(4)	(4)
<i>S. gracillimus</i>				
Home	56.5 \pm 29.7	68.0 \pm 7.9	48.2 \pm 29.4	48.2 \pm 18.5
Away	43.5	32.0	51.8	51.8
(N)	(4)	(4)	(5)	(4)

Table VI-4. Mean percentages of the utilization of "home" (\pm S.D.) or "away" cage by shrews for different dominant relations. The same letters indicate non-significant difference between the dominance relations in *S. caecutiens* ($\alpha=0.05$, ANOVA, arcsine transformation, Scheffe's method). The mean percentage did not differ significantly between "winner", "loser", and "no match" in *S. unguiculatus* and *S. gracillimus*. (N), number of individuals examined.

Dominance relation	Winner	Even	Loser	No match
<i>S. unguiculatus</i>				
Home	65.4 \pm 29.3	16.4	69.2 \pm 4.8	76.7 \pm 21.5
Away	34.6	83.6	30.8	23.3
(N)	(8)	(1)	(2)	(8)
<i>S. caecutiens</i>				
	a		a	b
Home	36.9 \pm 11.5	37.0	33.4 \pm 7.5	76.5 \pm 13.2
Away	63.1	63.0	66.6	23.5
(N)	(4)	(1)	(4)	(2)
<i>S. gracillimus</i>				
Home	32.2 \pm 10.7	-	59.3 \pm 19.6	72.6 \pm 14.5
Away	67.8	-	40.7	27.4
(N)	(2)	(0)	(5)	(2)

Experiment 2

The relative use of "home" or "away" cage was not significantly ($P \geq 0.05$) different between the experimental treatments (alone and with con- or hetero-specific individual) in the three species (Table VI-3). The use of "home" or "away" cage did not differ significantly between species when shrews were alone, although *S. unguiculatus* tended to stay in "home" cage more frequently than the other species (Table VI-3). The dominance relation did not affect the use of "home" or "away" cage in *S. unguiculatus* and *S. gracillimus*,

but *S. caecutiens* stayed in "home" cage more frequently when no combat was observed than when it was a "winner" or "loser" (Table VI-4).

When two individuals were put together into two interconnected cages, shrews tended to stay in different cages (Table VI-5). The mean percentage of staying in the same or different cage did not differ significantly among the treatments. However, *S. gracillimus* tended to stay in the same cage more frequently when coupled with conspecific individuals than when with heterospecific individual, though it was statistically non-significant.

Table VI-5. Occupation of cages by two shrews in Experiment 2. The mean percentages of staying in the same (\pm S.D.) and different cages are indicated. Numbers of experimental sessions are indicated in parentheses. The means did not differ significantly between any species combination ($\alpha=0.05$, ANOVA, arcsine transformation, Scheffe's method).

	with <i>S. u.</i>	with <i>S. c.</i>	with <i>S. g.</i>
<i>S. unguiculatus</i>			
Same	35.9 \pm 19.9	35.6 \pm 17.3	24.2 \pm 14.3
Different	64.1	64.4	75.8
(N)	(5)	(10)	(10)
<i>S. caecutiens</i>			
Same	-	33.9 \pm 19.6	38.4 \pm 15.0
Different	-	66.1	66.3
(N)		(5)	(9)
<i>S. gracillimus</i>			
Same	-	-	54.8 \pm 10.7
Different	-	-	45.2
(N)			(4)

S. unguiculatus stayed under the ground or dug soil significantly ($P < 0.05$) more frequently than *S. caecutiens* and

S. gracillimus when shrews were in "home" cages, but there was no significant difference in mean frequency of "underground & digging" between the latter two species (Fig. VI-5). *S. caecutiens* stayed in nest box or were resting on the ground surface more frequently than *S. unguiculatus* and *S. gracillimus*. The mean frequencies of the three behavioral categories did not differ significantly among the three species when they were in "away" cages (Fig. VI-5).

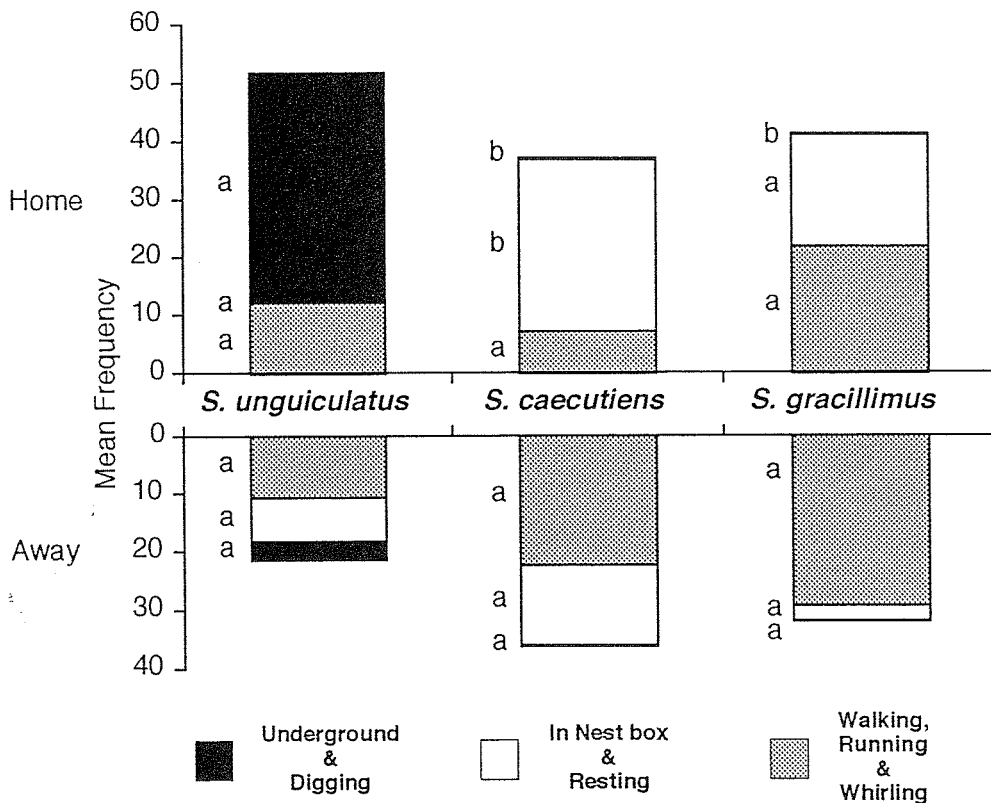
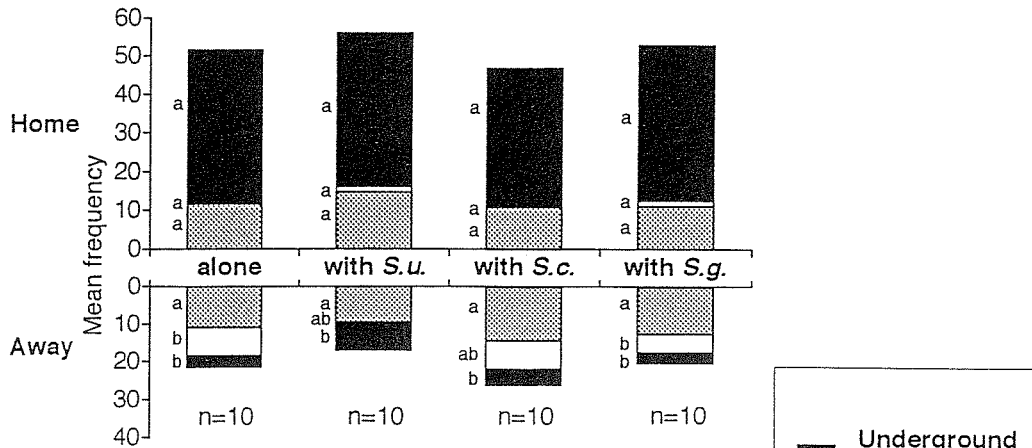
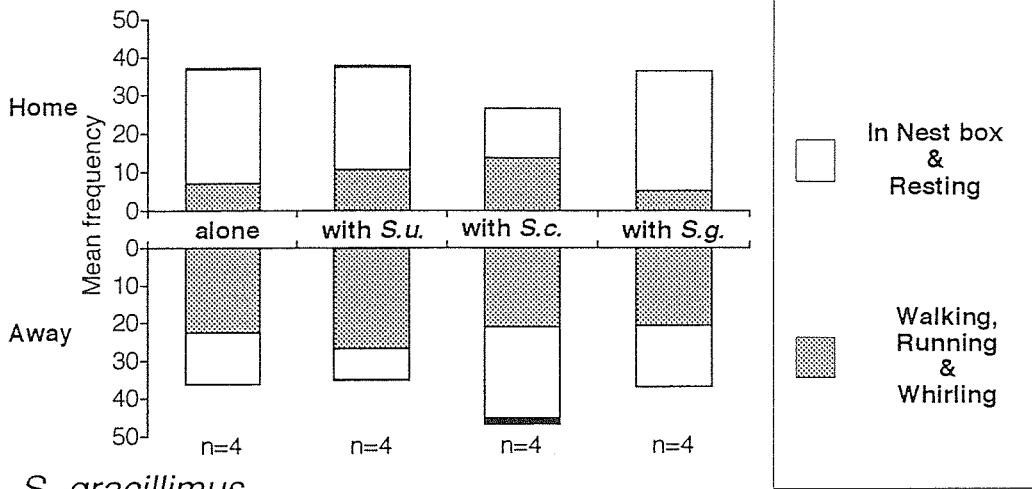

Fig. VI-5. Interspecific difference in the behavior of shrews when they were alone. The same letters indicate non-significant difference in mean frequency of each behavioral category between species for each of "home" and "away" cages ($\alpha=0.05$, ANOVA, Scheffe's method).

A. *S. unguiculatus*



B. *S. caecutiens*



C. *S. gracillimus*

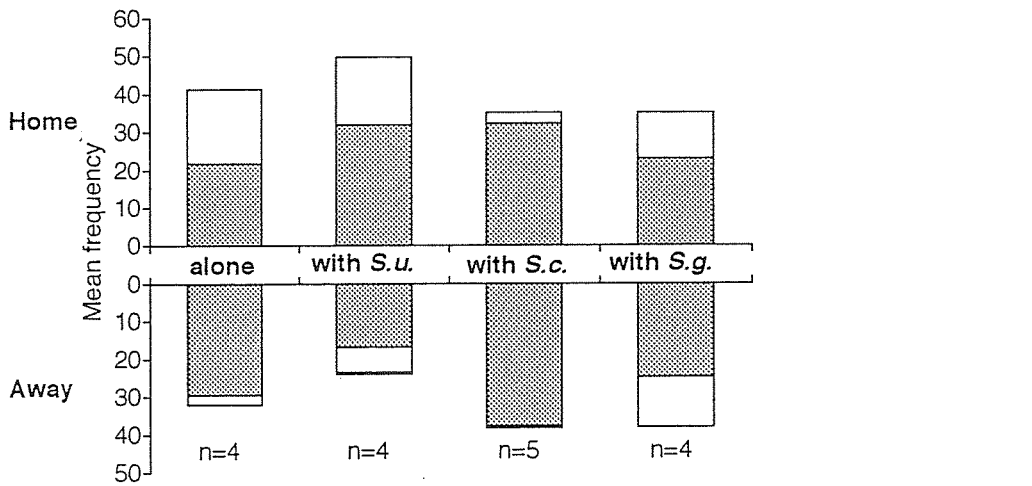
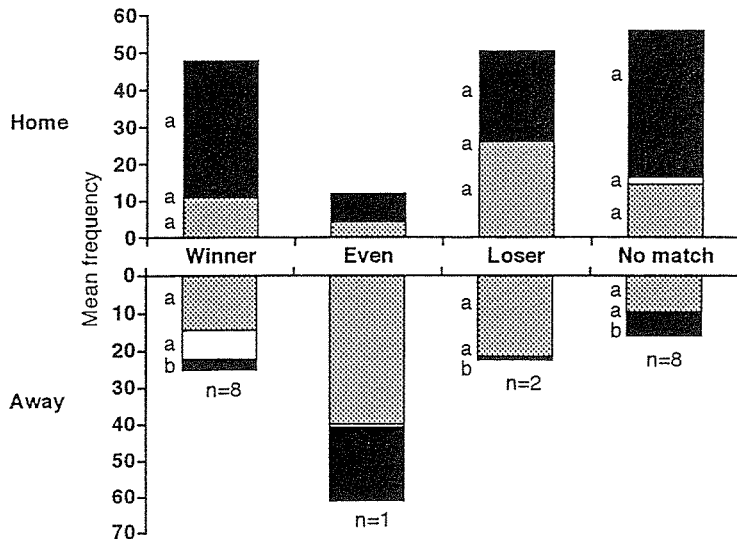
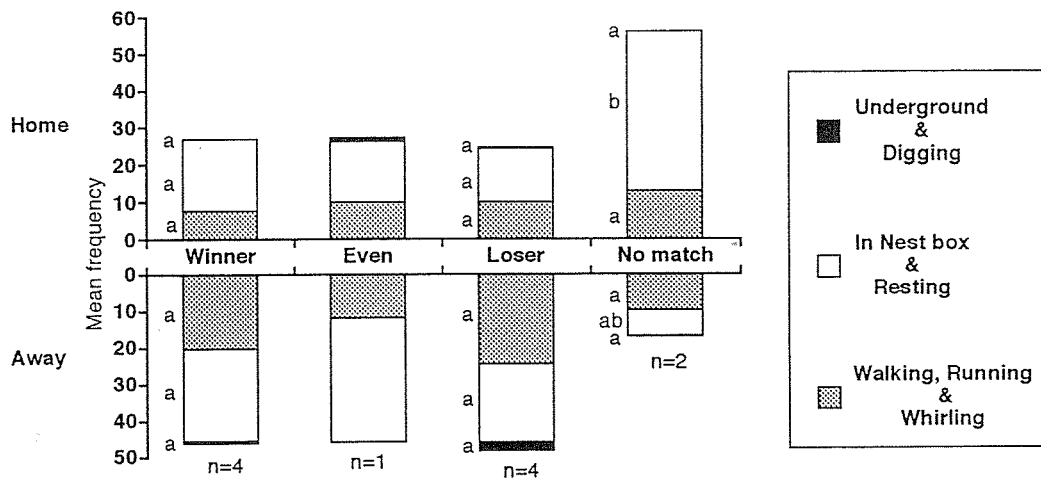

Fig. VI-6. The effects of con- or hetero-specific individual on the behavior of shrews. The same letters indicate non-significant difference in mean frequency of each behavior category between the experimental treatments and between "home" and "away" cages within experimental treatment ($\alpha=0.05$, ANOVA, Scheffe's method). In *S. caecutiens* and *S. gracillimus*, significant difference in each behavior category was not found between the experimental treatments nor between "home" and "away" cages.

A. *S. unguiculatus*



B. *S. caecutiens*



C. *S. gracillimus*

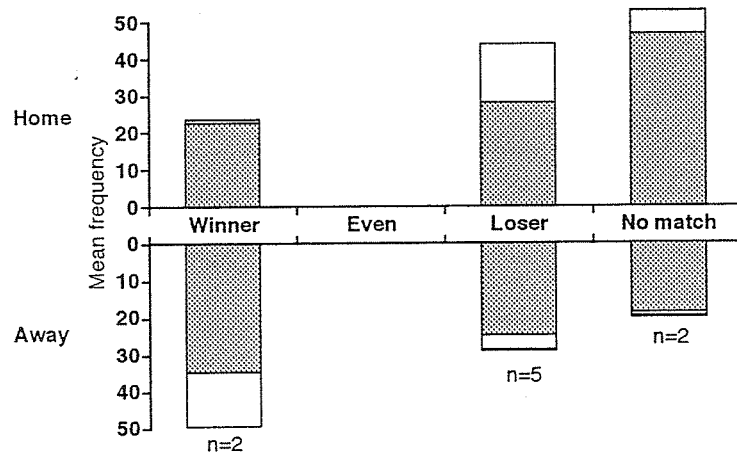

Fig. VI-7. Behaviors of shrews for each category of dominance relation. The same letters indicate non-significant difference in mean frequency of each behavior category between the categories of dominance relations and between "home" and "away" cages ($\alpha=0.05$, ANOVA, Scheffe's method). In *S. gracillimus*, significant difference in behavioral category was found neither between the categories of dominance relation nor between "home" and "away" cages.

S. unguiculatus performed "underground & digging" significantly more frequently in "home" cage than in "away" cage in all the experimental treatments (Fig. VI-6-A). The mean frequencies of the other two behavioral categories did not tend to differ significantly between in "home" and "away" cages, except for "in nest box & resting" when "alone" and when "with *S. gracillimus*" (Fig. VI-6-A). In *S. caecutiens* and *S. gracillimus*, the mean frequencies of the three behavioral categories did not differ significantly between in "home" and in "away" cages (Fig. VI-6-B, C). The experimental treatments (alone and with con- or hetero-specific individual) did not change the behavioral patterns in the three species (Fig. VI-6).

The mean frequencies of the three behavioral categories did not tend to be changed by the dominance relation (Fig. VI-7); however, in *S. caecutiens* the mean frequency of "in nest box & resting" in "home" cage was significantly greater in the case of "no match" than in the case of "winner" or "loser". In *S. unguiculatus*, mean frequency of "underground & digging" was greater in "home" cage than in "away" cage for all the dominance relations, but the frequencies of the three behaviors did not differ significantly between in "home" and in "away" cages for *S. caecutiens* and *S. gracillimus* (Fig. VI-7).

Dominance and attacks among shrews

S. unguiculatus was the strongest and *S. gracillimus* was the weakest among the three species. *S. unguiculatus* was seldom defeated by *S. caecutiens* and never defeated by *S. gracillimus* (Table VI-6). *S. caecutiens* won against *S. gracillimus* in most combats.

Table VI-6. Numbers of individuals for four kinds of dominance relations against con- or hetero-specific individual in Experiments 1 and 2. When the individuals were used in several sessions, those were counted repeatedly.

	against	<i>S. u.</i>	<i>S. c.</i>	<i>S. g.</i>
Experiment 1				
<i>S. unguiculatus</i>	win	4	6	6
	even	4	4	1
	lose	4	0	0
	no match	0	2	3
<i>S. caecutiens</i>	win	0	5	4
	even	4	4	2
	lose	6	5	1
	no match	2	0	2
<i>S. gracillimus</i>	win	0	1	2
	even	1	2	4
	lose	6	4	2
	no match	3	2	0
Experiment 2				
<i>S. unguiculatus</i>	win	1	6	8
	even	0	1	0
	lose	1	1	0
	no match	8	2	2
<i>S. caecutiens</i>	win	1	5	7
	even	1	0	0
	lose	6	5	0
	no match	2	0	2
<i>S. gracillimus</i>	win	0	0	4
	even	0	0	0
	lose	8	7	4
	no match	2	2	0

Table VI-7. Mean numbers of attacks (\pm S.D.) between two individuals in Experiment 2 for each dominance relation in three species. Numbers in parentheses refer to those given in Table VI-6. The same letters indicate non-significant difference ($\alpha=0.05$, Mann-Whitney's *U*-test, the sequential Bonferroni correction). The first letters before comma indicate the results of between-column comparisons and the second letters are those of between-rows.

	against	<i>S. u.</i>	<i>S. c.</i>	<i>S. g.</i>
<i>S. unguiculatus</i>	win	1 (1)	1.2 \pm 1.6 (6)	5.6 \pm 9.3 (8)
	even	- (0)	3 (1)	- (0)
	lose	0 (1)	0 (1)	- (0)
	total	0.5 \pm 0.7 (2) a, a	1.2 \pm 1.6 (8) a, a	5.6 \pm 9.3 (8) a, a
<i>S. caecutiens</i>	win	0 (1)	11.8 \pm 10.3 (5)	27.4 \pm 16.6 (7)
	even	3 (1)	- (0)	- (0)
	lose	0.8 \pm 1.3 (6)	1.0 \pm 1.0 (5)	- (0)
	total	1.0 \pm 1.4 (8) a, a	6.4 \pm 8.9 (10) a, a	27.4 \pm 16.6 (7) b, b
<i>S. gracillimus</i>	win	- (0)	- (0)	1.3 \pm 1.9 (4)
	even	- (0)	- (0)	- (0)
	lose	0.0 \pm 0.0 (8)	0.6 \pm 0.5 (7)	0.5 \pm 0.6 (4)
	total	0.0 \pm 0.0 (8) a, a	0.6 \pm 0.5 (7) b, a	0.9 \pm 1.4 (8) ab, a

S. unguiculatus showed no significant difference in the number of attacks against each of the three species (Table VI-7). *S. caecutiens* attacked *S. gracillimus* significantly more frequently than it did *S. unguiculatus* or *S. caecutiens*. *S. gracillimus* attacked *S. caecutiens* more frequently than did *S.*

unguiculatus, although the number of attacks was very small. *S. gracillimus* received more attacks from *S. caecutiens* than from *S. unguiculatus* and conspecific individuals (Table VI-7).

Discussion

S. unguiculatus frequently used subterranean space as its activity space, while *S. caecutiens* mainly used the ground surface (Figs. VI-3 and -5). *S. gracillimus* showed intermediate nature with respect to vertical space use in Experiment 1, but it was also regarded as a ground surface wanderer in Experiment 2 (Fig. VI-5), which simulated natural conditions more virtually than Experiment 1. The interspecific differences in space use were consistent with those in burrowing habit (Chapter IV) and diet constituents (Chapter II): *S. caecutiens* and *S. gracillimus*, which had lower burrowing ability and mainly ate small epigeal arthropods, showed more superficial activity than *S. unguiculatus*, which was a superior burrower and a heavy consumer of earthworms.

The presence of con- or hetero-specific individual and the dominance relation affected neither the space utilization nor the mean frequencies of behaviors (active/inactive and underground/resting/moving on the ground surface) in the three shrew species. *S. unguiculatus* was indigenously different in space use pattern from *S. caecutiens* and *S. gracillimus*. It is, therefore, likely that direct interaction or interfering for space use is less severe between *S.*

unguiculatus and either of *S. caecutiens* or *S. gracillimus* than between the latter two species.

Physical dominance order among soricids was apparent (Table VI-6) and seemed to correspond with the order of shrews' body size. The strongest *S. unguiculatus* is approximately twice as heavy as the second-ranked *S. caecutiens*, and *S. caecutiens* is 1.5 times as heavy as the weakest *S. gracillimus* (Ohdachi & Maekawa 1990). The correlation between fighting ability and body size has been reported in insectivorous or carnivorous vertebrates (e.g., Persson 1985, Alatalo & Moreno 1987, Dickman 1988, Erlinge & Sandell 1988, Ducey *et al.* 1994, Nakano & Furukawa-Tanaka 1994). Their predatory nature and interfering habits may be related with the consequence of fighting (refer to Polis & Myers 1985, Persson 1988, Elgar & Crespi 1991).

All the three species of shrews always demonstrated antagonistic behavior when two con- or hetero-specific individuals encountered. This may have led the tendency that a shrew stayed in cage different from that where the opponent stayed (Table VI-5). Most of other soricids show antagonism against con- or hetero-specific individuals (Crowcroft 1957, Olsen 1969, Hawes 1977, Martin 1981, Barnard & Brown 1982, Churchfield 1990, Ellenbroek 1990, Dickman 1991, Krushinska & Rychlik 1993), but some species, such as *Neomys anomalus* and *Cryptotis parva*, exhibit tolerant behavior among conspecific individuals (Broadbooks 1952, Conaway 1958, Mock 1982, Krushinska & Pucek 1989, Krushinska & Rychlik 1993). Krushinska and Pucek (1989)

reported that acquaintance reactions, such as warning, signals, and nasal contact, were observed in *N. anomalus* and that shrews gradually came to avoid direct fighting by learning the dominance ranks. In the present study, such acquaintance behaviors were not observed, although experimental situations were different; shrews suddenly attacked other individuals (or were attacked) when two individuals encountered. The lack of acquaintance behavior might lead the intolerance reactions among the shrews in Hokkaido.

Although *S. unguiculatus* was stronger than the other two species, the number of attacks against other individuals was small (Table VI-7). Attacking behaviors could be observed only on the ground surface in the present study, which might underestimate the attacking frequency of *S. unguiculatus*. In natural condition, also, attack of *S. unguiculatus* against *S. caecutiens* and *S. gracillimus* is probably rare, because the latter two species use only a little subterranean space. It should be noted that *S. caecutiens* attacked *S. gracillimus* most frequently, and *S. gracillimus* was attacked most frequently by *S. caecutiens*.

The results of the present experiments are to be related to field observations. Soricids usually establish intraspecific territories or exclusive home ranges, especially among individuals of the same sex (Ingles 1961, Shillito 1963, Buckner 1966, 1969, Croin-Michielsen 1966, Platt 1976, Hawes 1977, Pernetta 1977, Inoue 1988, 1991, Ohdachi 1992, Ivanter *et al.* 1994, Moraleva & Telitzina 1994, Stockley *et al.*

1994), and the territoriality seems to be maintained by aggressive behavior and odor marking (Crowcroft 1957, Hawes 1976). Two types of interspecific relationships of spacing are known in soricine shrews. One type is overlapped territories between species, as in *S. araneus* and *S. minutus* (Croin-Michielsen 1966, Pernetta 1977, Ellenbroek 1980). The other is interspecific territoriality as in *S. cinereus* and *S. vagrans* (Spencer & Pettus 1966) and in *S. vagrans* and *S. obscurus* (Hawes 1977). For the shrews in Hokkaido, *S. unguiculatus* and *S. gracillimus* or *S. caecutiens* appear to have overlapped territories (Ohdachi 1992). The overlapped home range between them could be explained by the interspecific difference in vertical space use: *S. unguiculatus* and *S. gracillimus* or *S. caecutiens* appear to scarcely encounter each other in the field. By contrast, it is plausible that *S. caecutiens* and *S. gracillimus* have interspecific territories, because both of them use mainly the ground surface and they do not displace the space of activity even when they co-habit.

S. caecutiens tenaciously attacks *S. gracillimus*, and the latter seldom wins against *S. caecutiens*. The similarity in space use and physical inferiority can lead the exclusion of *S. gracillimus* from habitats where *S. caecutiens* exists. Moreover, receivers of aggressive behavior may reduce fitness in general (King 1973). This could partly explain the relative abundances of the two species in a habitat (Chapter II): *S. caecutiens* and *S. gracillimus* did not occur together as the most and second most abundant species. However, if *S.*

caecutiens always excluded *S. gracillimus* from any habitats, *S. gracillimus* should not be distributed in Hokkaido. In reality, *S. gracillimus* outnumbered *S. caecutiens* and *S. unguiculatus* in some habitats (Chapter II). This might be attributed to interspecific difference in habitat preference. *S. gracillimus* was the relatively most abundant in moor and highlands, especially, in northern Hokkaido, while *S. caecutiens* tended to outnumber other species in habitats with sandy soil or volcanic ashes (Chapter II). This implies that each species prefers particular environments. In addition, competitive ability may change along with the environmental variations of habitats, such as temperature, humidity, or soil type. Further experiments of interspecific interactions need to be conducted under various conditions, such as temperature and humidity, to evaluate the relative importance of competitive ability, habitat preference, and other factors for guild organization of shrews in Hokkaido.

Chapter VII

Synthesis

In this final chapter, I integrate the results of Chapters II—VI and give some interpretations about the role of interspecific interaction for the organization (or maintenance) of soricid guilds in Hokkaido. Variations in relative abundance of shrew species among habitats imply that a negative ecological interaction exists between *S. caecutiens* and *S. gracillimus* since they did not occur together as the most and the second most abundant species (Chapter II). *S. caecutiens* and *S. gracillimus* consumed small epigeal arthropods as their main prey, and the dietary niche was similar between them (Chapter III). Their space use patterns were also similar to one another: their main activity space was the ground surface (Chapter VI). In addition, *S. caecutiens* and *S. gracillimus* had similar behavioral characteristics in daily activity rhythm and burrowing habit (Chapters IV and V). Hence, it is suggested that *S. caecutiens* and *S. gracillimus* compete for food resource and space with each other.

Aggressive behavior was observed most frequently between *S. caecutiens* and *S. gracillimus*, and *S. caecutiens* was usually a winner in combats between them (Chapter VI). The antagonistic behavior and no shift of space use despite the presence of heterospecific individual may partly explain their relationship in relative abundance between *S. caecutiens* and *S. gracillimus*. Namely, *S. caecutiens* could exclude *S. gracillimus* from a habitat because of its interfering superiority. However, other factors also must be considered to interpret the shrews' distribution and relative abundance

in Hokkaido. *S. gracillimus* outnumbered *S. caecutiens* in some habitats. This means that the relative abundance is not determined solely by the physical superiority, or that competitive ability varies among different environmental conditions, such as temperature, humidity, or soil type.

Exclusive tendency between *S. caecutiens* and *S. gracillimus* was incomplete: they did 'coexist', although the relative abundance of either of them was small. The incompleteness in mutual exclusion might be explained by the following hypotheses: (1) nested relationship in competitive ability among con- or hetero-specific individual (Hino 1986, Nakano & Furukawa-Tanaka 1994), (2) the presence of other species, such as predators (Paine 1974) and the third unknown competitors (May & Leonard 1975), and (3) non-equilibrium populations (Brown & Heske 1990, Chesson & Case 1986, Hanski 1986) or the lottery effect with vacant space (Chesson 1983) in relation to fluctuating environments (Chesson 1986, Grant 1986). These hypotheses remain to be proved in future studies.

Next, guild structure of soricids is compared among some regions of the world to find a general pattern of the guild organization. A common structure of soricid guilds among Europe, eastern North America, and Hokkaido is to have an earthworm specialist plus one or more species which feed principally on epigeal arthropods (see also Abe 1985). In western and Western Europe and Great Britain, *S. araneus* and *S. minutus* coexist. The former species is large and eats earthworms, slugs, and small arthropods, while the latter is

small and eats mainly small arthropods but few earthworms (Rudge 1968, Pernetta 1977, Grainger & Fairley 1978, Butterfield *et al.* 1981, Bauerová 1984, Churchfield 1984). *S. araneus* can make burrows (Churchfield 1980), although its ability is much poorer than *S. unguiculatus* in Hokkaido. *S. minutus* seems to have little burrowing ability (Croin-Michielsen 1966, Butterfield *et al.* 1981, Ellenbroek 1990). Hence, *S. araneus* and *S. minutus* appear ecologically and morphologically "equivalent" to *S. unguiculatus* and *S. gracillimus* in Hokkaido, respectively. *S. caecutiens* also coexists with *S. araneus* and *S. minutus* in northern Europe but tends to be less abundant in syntopy with *S. minutus* (Hanski 1986). However, *S. caecutiens* tends to be more abundant than *S. minutus* in central Siberia (Sheftel 1989, 1994, Shvarts & Demin 1994). In central Siberia, other shrew species, such as *S. minutissimus* and *S. isodon*, also occur in addition to the three species, but they are rare. This is also similar to the numerical relationship between *S. caecutiens* and *S. gracillimus* in Hokkaido (Chapter II).

Blarina brevicauda in eastern North America is large and its main prey items are earthworms and slugs (Babcock 1914, Whitaker & Mumford 1972). In various regions, smaller epigeal soricine species coexist with *B. brevicauda* e.g., *S. cinereus* in Michigan and Manitoba (Getz 1961, Whitaker & Mumford 1972, French 1984, Whitaker & French 1984, Ryan 1986) and *S. arcticus* in Manitoba (Buckner 1957, 1966, Wrigley *et al.* 1979). *B. brevicauda* and the small

epigeal species are ecologically equivalent to *S. unguiculatus* and *S. gracillimus/S. caecutiens* in Hokkaido, respectively.

Two processes appear to operate in maintaining soricid guilds in Europe, eastern North America, and Hokkaido: coexistence with less interactive relation (subterranean forager vs. epigeal forager) and interspecific competition among small epigeal species. Furthermore, there is only one subterranean species in a guild, whereas several epigeal species can coexist. Abe (1983) pointed out that interference for space and food resource may be more severe among burrowers than among surface wanderers, because burrow is a uni-dimensional closed space. Interspecific competition seems to be a major constraint for a burrowing species to join in a species assemblage or guild.

Interspecific interaction seems to have different impacts according to the difference between the processes of maintenance and formation of the soricid guilds. In general, the role of interspecific interaction among community members will differ among different temporal and spatial scales (e.g., Wiens *et al.* 1986, Bennett 1990, Schneider 1994). Thus, multiple-scaled investigation (Bennett 1990) is needed in the future to complete the interpretation of guild organization of soricids.

The convergence of guild structure of those soricids may be explained by non-competitive process among guild members. For instance, guild structures may have converged through adaptation to environments of each species. To evaluate the relative importance between competitive process

and adaptation of each species, history of guilds formation, such as geographic and phylogenetic origin and speciation period of the guild members, should also be investigated in the future.

Acknowledgments

I thank M. J. Toda, S. F. Mawatari, H. Abe, and T. Ohgushi for being committee members of my dissertation. In particular, M. J. Toda gave me the opportunity to study at his laboratory and encouraged me through the study.

In the study of geographic distribution, K. Maekawa partly collaborated with me. M. Yoneda permitted me to use the data of his Ph.D. dissertation, and H. Abe, N. Kondo, K. Takahashi, and T. Shida supplied their unpublished data for me. Students of Institute of Applied Zoology Hokkaido Univ., members of Shiretoko Animal Research Group, and staff members of the Experimental Forests of Hokkaido Univ. and the Univ. of Tokyo, and M. Satoh and other staff members of Rishiri-cho museum supported our field survey.

S. Honma and T. Yoshida kindly helped me to make the device for measuring animal activity. K. Ishigaki, K. Sasa, and other staff members of the Experimental Forests of Hokkaido University supported my field work. T. Segawa, S. Nakatsubo, and H. Ishii made utensils for keeping shrews and experimental cages. K. Shimada and students of Zoological Section, Institute of Low Temperature Science and Laboratory of Applied Zoology, Faculty of Agriculture, Hokkaido Univ. assisted me in the field and laboratory work.

H. Mori, Y. Saito, T. Saito, S. Churchfield, S. Nakano, and G. L. Kirkland, Jr. reviewed earlier versions of some parts of the dissertation. E. Kasuya and S. Kudo discussed some statistical problems with me, but responsibility for statistical analyses totally rests with me. I sincerely express my gratitude to all of them.

Summary

Geographic distribution, diets, behaviors (daily activity, burrowing habit, space use, and aggression) and other topics were investigated for soricine shrews in Hokkaido (Insectivora, Mammalia). The purpose of this dissertation is to clarify the difference in life history among the shrews and give essential information about competitive interactions between them.

S. unguiculatus, *S. caecutiens*, and *S. gracillimus* were distributed throughout Hokkaido, while *S. minutissimus* was recorded only in northern and eastern parts. *S. unguiculatus* was the most abundant in a number of habitats. *S. caecutiens* and *S. gracillimus* were the second or third most abundant species in many habitats, but they became the most abundant in some habitats. *S. minutissimus* was very rare in Hokkaido. *S. caecutiens* and *S. gracillimus* did not occur together as the most and second most abundant species.

S. unguiculatus mainly ate earthworms, while principal prey of *S. caecutiens* and *S. gracillimus* was small epigeal arthropods, such as insects, spiders, and harvestmen. Abundance of the shrews varied among habitat types, but abundances of *S. unguiculatus* and *S. gracillimus* seemed to be unrelated with those of their principal foods.

S. unguiculatus, *S. caecutiens*, and *S. gracillimus* were more active during the dark periods than during light periods.

Activity during the dark period was polymodal in all the three species under the 10L14D & 5–15 °C regime, but was bimodal in *S. unguiculatus* under the 16L8D & 20 °C regime. The actogram pattern of *S. caecutiens* was intermediate between those of *S. unguiculatus* and *S. gracillimus*.

S. unguiculatus showed strong burrowing ability, while *S. caecutiens* and *S. gracillimus* had poor burrowing ability. *S. unguiculatus* preferred earthworms, but *S. caecutiens* and *S. gracillimus* hesitated to eat them.

S. unguiculatus frequently used the strata below the surface floor of experimental cages or subterranean burrows as space of its activity, while *S. caecutiens* and *S. gracillimus* mainly used the surface floor or the ground surface. The presence of con- or hetero-specific individual and physical dominance relations (win, even, lose, or no match) changed neither patterns of vertical and horizontal space use nor behavioral patterns (active/inactive and underground/resting/moving on ground surface) in the three shrew species. *S. unguiculatus* was the strongest, *S. caecutiens* was intermediate, and *S. gracillimus* was the weakest in terms of physical superiority. Aggressive behavior was observed most frequently between *S. caecutiens* and *S. gracillimus*.

Difference in relative abundance among habitats implies that there is a negative interaction between *S. caecutiens* and *S. gracillimus*. Results of diet analysis and daily activity, burrowing habit, and space use proved that *S. caecutiens* and *S. gracillimus* possessed similar ecological requirements and behavioral patterns. Thus, it is suspected that interspecific

competition be more severe between *S. caecutiens* and *S. gracillimus* than between either of them and *S. unguiculatus*, and influence the formation of soricid guild in Hokkaido. Aggressive behavior was observed most frequently between *S. caecutiens* and *S. gracillimus*, and interference interaction appears to exist between them. A common pattern of guild structures of soricids was recognized among some regions of the world: they consist of an earthworm specialist plus one or more species that tend to feed principally on epigeal arthropods. To complete the interpretation of the organization of soricid guilds, results of multiple-scaled investigation for interspecific interaction and historical information of guild organization should be obtained in the future.

Literature Cited

- Abe, H. 1961. Two rare mammals obtained in Hokkaido (in Japanese and English). *Journal of the Mammalogical Society of Japan*, 2: 3-7.
- Abe, H. 1967. Classification and biology of Japanese Insectivora (Mammalia) I. Studies on variation and classification. *The Journal of Faculty of Agriculture, Hokkaido University*, 55: 191-269.
- Abe, H. 1968. Classification and biology of Japanese Insectivora (Mammalia) II. Biological aspects. *The Journal of Faculty of Agriculture, Hokkaido University*, 55: 429-458.
- Abe, H. 1983. Distribution and radiation in soricid shrews (in Japanese). *Honyurui Kagaku (Mammalian Science)*, 46: 46-57.
- Abe, H. 1984. Rodents and shrews (in Japanese). *Hokkaido no Shizen (Sapporo)*, 23: 25-29.
- Abe, H. 1985. Classification, distribution and ecology of the Soricidae, considered from the standpoint of adaptive radiation (in Japanese with English abstract). *In Suncus. Biology of Soricids as Experimental Animals.* (Kondo, K., ed.). Pp. 20-37, Gakkai Syuppan Center, Tokyo.
- Abe, H. 1988. Insectivora (in Japanese). *In Report on the Distributions of Animals and Plants. Mammals.*

- (Agency of Environment, ed.). Pp. 162-163, Agency of Environment of Japan, Tokyo.
- Abe, H., K. Maekawa and A. Gotoh. 1978. Mammals of Shimokawa-cho (in Japanese). Shimokawa-cho, governmental office, Hokkaido.
- Aitchison, C. W. 1987. Winter energy requirements of soricine shrews. *Mammal Review*, 17: 25-38.
- Alatalo, R. V. and J. Moreno. 1987. Body size, interspecific interactions, and use of foraging sites in tits (Paridae). *Ecology*, 65: 1773-1777.
- Aoki, J. 1973. Soil Zoology (in Japanese). Hokuryukan, Tokyo.
- Arthur, W. 1987. *The Niche in Competition and Evolution*. John Wiley and Sons, Chichester.
- Asagawa, M. and Y. Asagawa. 1991. A record of the collection of small mammals on islands of Hokkaido, May-September, 1990 (in Japanese). *Shinrin Hogo (Forest Conservation)*, 224: 26-28.
- Babcock, H. L. 1914. Some observations on the food habits of the short-tailed shrew (*Blarina brevicauda*). *Science*, 40: 526-530.
- Barnard, C., J. and C. A. J. Brown. 1982. The effects of prior residence, competitive ability and food availability on the outcome of interactions between shrews (*Sorex araneus* L.). *Behavioral Ecology and Sociobiology*, 10: 307-312.

- Bauerová, Z. 1984. The food eaten by *Sorex araneus* and *Sorex minutus* in a spruce monoculture. *Folia Zoologica*, 33: 125-132.
- Bennett, W. A. 1990. Scale of investigation and the detection of competition: an example from the house sparrow and house finch introductions in North America. *The American Naturalist*, 135: 725-747.
- Broadbooks, H. E. 1952. Nest and behavior of a short-tailed shrew, *Cryptotis parva*. *Journal of Mammalogy*, 33: 241-243.
- Brown, J. H. and E. J. Heske. 1990. Temporal changes in a Chihuahuan desert rodent community. *Oikos*, 59: 229-302.
- Brown, J. L. 1969. The buffer effect and productivity in tits populations. *The American Naturalist*, 103: 347-354.
- Buchalczyk, A. 1972. Seasonal variations in the activity of shrews. *Acta Theriologica*, 17: 221-243.
- Buckner, C. H. 1957. Population studies on small mammals of southeastern Manitoba. *Journal of Mammalogy*, 38: 87-97.
- Buckner, C. H. 1964. Metabolism, food capacity, and feeding behavior in four species of shrews. *Canadian Journal of Zoology*, 42: 259-279.
- Buckner, C. H. 1966. Populations and ecological relations of shrews in tamarack bogs of southeastern Manitoba. *Journal of Mammalogy*, 47: 181-194.

- Buckner, C. H. 1969. Some aspects of the population ecology of the common shrew, *Sorex araneus*, near Oxford, England. *Journal of Mammalogy*, 50: 326-332.
- Butterfield, J., J. C. Coulson and S. Wanless. 1981. Studies on the distribution, food, breeding biology and relative abundance of the pygmy and common shrews (*Sorex minutus* and *S. araneus*) in upland areas of northern England. *Journal of Zoology*, London, 195: 169-180.
- Chesson, P. L. 1983. Coexistence of competitors in a stochastic environment: the storage effect. *In* *Population Biology*. (Freedman, H. I. and C. Strobeck, ed.). Pp. 188-198, Springer-Verlag, Berlin.
- Chesson, P. L. 1986. Environmental variation and the coexistence of species. *In* *Community Ecology*. (Diamond, J. M. and T. J. Case, ed.). Pp. 240-256, Harper & Row, New York.
- Chesson, P. L. and T. J. Case. 1986. Overview: nonequilibrium community theories: chance, variability, history, and coexistence. *In* *Community Ecology*. (Diamond, J. M. and T. J. Case, ed.). Pp. 229-239, Harper & Row, New York.
- Churchfield, S. 1980. Subterranean foraging and burrowing activity of the common shrew. *Acta Theriologica*, 25: 451-459.
- Churchfield, S. 1984. Dietary separation in three species of shrew inhabiting water-cress beds. *Journal of Zoology*, London, 204: 211-228.
- Churchfield, S. 1990. *The Natural History of Shrews*. A & C Black., London.

- Churchfield, S. 1991. Niche dynamics, food resources, and feeding strategies in multispecies communities of shrews. *In* The Biology of the Soricidae. (Findley, J. S. and T. L. Yates, ed.). Pp. 23-34, The Museum of Southwestern Biology, University of New Mexico, Albuquerque.
- Conaway, C.H. 1958. Maintenance, reproduction and growth of the least shrew in captivity. *Journal of Mammalogy*, 39: 507-512.
- Connell, J. H. 1983. On the prevalence and relative importance of interspecific competition: evidence from field experiments. *The American Naturalist*, 122: 661-696.
- Croin-Michielsen, N. 1966. Intraspecific and interspecific competition in the shrews *Sorex araneus* L. and *S. minutus* L. *Archives Néerlandaises de Zoologie*, 18: 73-174.
- Crowcroft, P. 1957. *The Life of the Shrew*. Max Reinhardt, London.
- Diamond, J. M. 1986. Overview: laboratory experiments, field experiments, and natural experiments. *In* Community Ecology. (Diamond, J. M. and T. J. Case, ed.). Pp. 3-22, Harper & Row, New York.
- Dickman, C. R. 1986. An experimental study of competition between two species of dasyurid marsupials. *Ecological Monographs*, 56: 221-241.

- Dickman, C. R. 1988. Body size, prey size, and community structure in insectivorous mammals. *Ecology*, 69: 569-580.
- Dickman, C. R. 1991. Mechanisms of competition among insectivorous mammals. *Oecologia*, 85: 464-471.
- Dokuchaev, N. E. 1990. Ecology of North-eastern Asiatic Shrews (in Russian). Nauka, Moscow.
- Dolgov, V. A. 1985. Shrews in the North, South, East and West (in Russian). Moscow University Press, Moscow.
- Ducey, P. K., K. Schramm and N. Cambry. 1994. Interspecific aggression between the sympatric salamanders, *Ambystoma maculatum* and *Plethodon cinereus*. *The American Midland Naturalist*, 131: 320-329.
- Elgar, M. A. and B. J. Crespi. 1991. Ecology and evolution of cannibalism. *In* *Cannibalism. Ecology and evolution among diverse taxa.* (Elgar, M. A. and B. J. Crespi, ed.). Pp. 1-12, Oxford University Press, Oxford.
- Ellenbroek, F. J. M. 1980. Interspecific competition in the shrews *Sorex araneus* and *Sorex minutus* (Soricidae, Insectivora): a population study of the Irish pygmy shrew. *Journal of Zoology, London*, 192: 119-136.
- Ellenbroek, F. J. M. 1990. An Experimental Analysis of Interspecific Competition in the Shrews *Sorex araneus* L. and *S. minutus* L. (Soricidae, Insectivora). H. Gianotten, Tilburg.
- Ellenbroek, F. J. M. and J. Hamburger. 1991. Interspecific interactions between the shrews *Sorex araneus* L. and *S. minutus* L. (Soricidae, Insectivora) and the use of

- habitat: a laboratory study. Netherlands Journal of Zoology, 41: 32-62.
- Erlinge, S. and M. Sandell. 1988. Coexistence of stoat, *Mustela erminea*, and weasel, *M. nivalis*: social dominance, sent communication, and reciprocal distribution. Oikos, 53: 242-246.
- Fox, B. J. and G. L. Kirkland Jr. 1992. An assembly rule for functional groups applied to North American soricid communities. Journal of Mammalogy, 73: 491-503.
- French, T. W. 1984. Dietary overlap of *Sorex longirostris* and *S. cinereus* in hardwood floodplain habitats in Vigo country, Indiana. The American Midland Naturalist, 111: 41-46.
- Fujiwara, K., K. Sasa and F. Satoh. 1994. Distribution of snow cover in the Teshio and Nakagawa Experimental Forest, Hokkaido University (in Japanese with English summary). Research Bulletins of the Hokkaido University Forests, 51: 74-88.
- Genoud, M. 1984. Activity of *Sorex coronatus* (Insectivora, Soricidae) in the field. Zeitschrift für Säugetierkunde, 49: 74-78.
- Genoud, M. 1988. Energetic strategies of shrews: ecological constraints and evolutionary implication. Mammal Review, 18: 173-193.
- Getz, L. L. 1961. Factors influencing the local distribution of shrews. The American Midland Naturalist, 65: 67-88.

- Grainger, J. P. and J. S. Fairley. 1978. Studies on the biology of the pygmy shrew *Sorex minutus* in the west of Ireland. *Journal of Zoology*, London, 186: 109-141.
- Grant, P. R. 1986. Interspecific competition in fluctuating environments. *In* *Community Ecology*. (Diamond, J. M. and T. J. Case, ed.). Pp. 173-191, Harper & Row, New York.
- Hanski, I. 1984. Food consumption, assimilation and metabolic rate in six species of shrew (*Sorex* and *Neomys*). *Annales Zoologici Fennici*, 21: 157-165.
- Hanski, I. 1986. Population dynamics of shrews on small islands accord with the equilibrium model. *Biological Journal of the Linnean Society*, 28: 23-36.
- Hanski, I. 1989. Population biology of Eurasian shrews: towards a synthesis. *Annales Zoologici Fennici*, 26: 469-479.
- Hardin, G. 1960. The competitive exclusion principle. *Science*, 131: 1292-1297.
- Hawes, M. L. 1976. Odor as a possible isolating mechanism in sympatric species of shrews (*Sorex vagrans* and *Sorex obscurus*). *Journal of Mammalogy*, 57: 404-406.
- Hawes, M. L. 1977. Home range, territoriality, and ecological separation in sympatric shrews, *Sorex vagrans* and *Sorex obscurus*. *Journal of Mammalogy*, 58: 354-367.
- Hino, T. 1986. Intra- and Interspecific relationships of resource use in a mixed-species flock of bird in winter (in Japanese). *Kotaigun-seitai Gakkai Kaihou* (Society of Population Ecology), 41: 47-51.

- Holbrook, S. J. 1979. Habitat utilization, competitive interactions, and coexistence of three species of cicetine rodents in east-central Arizona. *Ecology*, 60: 758-769.
- Honma, S., N. Kanematsu and K.-I. Honma. 1992. Entrainment of methamphetamine-induced locomotor rhythm to feeding cycles in SCN-lesioned rats. *Physiology & Behavior*, 52: 843-850.
- Imaizumi, Y. 1960. Coloured Illustrations of the Mammals of Japan (in Japanese). Hoikusha Publishing, Tokyo.
- Imaizumi, Y. 1972. Land mammals of the Hidaka mountains, Hokkaido, Japan, with special reference to the origin of an endemic species of the genus *Clethrionomys* (in Japanese with English summary). *Kokuritsu Kagaku Hakubutsukan Senpou*, 5: 131-149.
- Ingles, L. G. 1961. Home range and habitats of the wandering shrew. *Journal of Mammalogy*, 42: 455-462.
- Inoue, T. 1988. Territory establishment of young big-clawed shrew, *Sorex unguiculatus* (Dobson) (Insectivora, Soricidae). *Researches on Population Ecology*, 30: 83-93.
- Inoue, T. 1991. Sex difference in spatial distribution of the big-clawed shrew *Sorex unguiculatus*. *Acta Theriologica*, 36: 229-237.
- Inoue, T. and K. Maekawa. 1990. Difference in diets between two species of soricine shrews, *Sorex unguiculatus* and *S. caecutiens*. *Acta Theriologica*, 35: 253-260.
- Itô, Y., N. Yamamura and M. Shimada. 1992. *Doubutsu Seitaigaku* (Animal Ecology, in Japanese). Soju Shobo, Tokyo.

- Ivanter, E. V., T. Ivanter and A. M. Makarow. 1994. The territorial and demographic structures of a common shrews population. *In* Advances in the Biology of Shrews. (Merritt, J. F., G. L. Kirkland Jr. and R. K. Rose, ed.). pp. 89-96, Carnegie Museum of Natural History, Pittsburgh.
- Jánský, V. L. and V. Hanák. 1960. Studien über Kleinsäugerpopulationen in Südböhmen. II. Aktivität der Spitzmäuse unter natürlichen Bedingungen. *Säugetierkundliche Mitteilungen*, 8: 55-63.
- Keddy, P. A. 1989. Competition. Chapman and Hall, London.
- Kholin, S. K. 1993. Insular biogeography of southern Kurile islands: fauna formation, species number and composition of terrestrial vertebrates and carabid beetles (in Russian with English summary). *Zoologičeskij Jhurnal*, 72: 137-146.
- King, J. A. 1973. The ecology of aggressive behavior. *Annual Review of Ecology and Systematics*, 4: 117-138.
- Kirkland, G. L., . Jr. 1991. Competition and coexistence in shrews (Insectivora: Soricidae). *In* The Biology of the Soricidae. (Findley, J. S. and T. L. Yates, ed.). Pp. 15-22, The Museum of Southwestern Biology, University of New Mexico, Albuquerque.
- Komiya, T. 1970. A record of *Sorex minutissimus hawkeri* from Hokkaido (in Japanese). *Journal of the Mammalogical Society of Japan*, 5: 195.
- Kondo, N. 1983. Mammals, amphibians, and reptiles (in Japanese). *In* Report on Environmental Assessment of

- Kushiro moor. (Natural Conservation Section of Hokkaido, ed.). Pp. 97-112, Hokkaido government, Sapporo.
- Kondo, N. 1986. Mammals (in Japanese). *In* Report on the Natural History of Akkeshi Prefectural Park. (Natural Conservation Section of Hokkaido, ed.). Pp. 129-141, Hokkaido government, Sapporo.
- Krushinska, N. L. and Z. Pucek. 1989. Ethological study of sympatric species of European water shrews. *Acta Theriologica*, 34: 269-285.
- Krushinska, N. L. and L. Rychlik. 1993. Intra- and interspecific antagonistic behaviour in two sympatric species of water shrews: *Neomys fodiens* and *N. anomalus*. *Journal of Ethology*, 11: 11-21.
- Lardet, J.-P. 1988. Spatial behaviour and activity patterns of the water shrew *Neomys fodiens* in the field. *Acta Theriologica*, 33: 293-303.
- Levins, R. 1968. *Evolution in Changing Environments: Some theoretical Explorations*. Princeton University Press, Princeton.
- Macdonald, D. 1984. *The Encyclopedia of Mammals. Facts on File*, New York.
- Maekawa, K. 1981. Distribution of shrews in Shiretoko peninsula, Hokkaido. *In* Report of the survey on vertebrate communities in Shiretoko peninsula, Hokkaido, Japan. (Natural Conservation Section of Hokkaido, ed.). Pp. 98-104, Hokkaido government, Sapporo.

- Martin, I. G. 1981. Tolerance of conspecifics by short-tailed shrews (*Blarina brevicauda*) in simulated natural conditions. *The American Midland Naturalist*, 106: 206-208.
- May, R. M. and W. Leonard. 1975. Nonlinear aspects of competition between three species. *SIAM Journal of Applied Mathematics*, 29: 243-253.
- McNab, B. K. 1991. The energy expenditure of shrews. *In The Biology of the Soricidae*. (Findley, J. S. and T. L. Yates, ed.). Pp. 35-46, the Museum of Southwestern Biology, University of New Mexico, Albuquerque.
- Menge, B. A. and J. P. Sutherland. 1976. Species diversity gradient; synthesis of the role of predation, competition, and temporal heterogeneity. *The American Naturalist*, 110: 351-369.
- Miyao, T., T. Yanagidaira, T. Morozumi, M. Morozumi, T. Mouri and I. Yamamoto. 1970. A record of the collection of small mammals on Rishiri and Rebun islands and in some regions of mainland Hokkaido (in Japanese). *Shinsyu Honyurui Kenkyukai Kaihou*, 9: 1-6.
- Mock, O. B. 1982. The least shrew (*Cryptotis parva*) as a laboratory animal. *Laboratory Animal Science*, 32: 177-179.
- Moraleva, N. and A. Telitzina. 1994. Territoriality in juveniles of the common shrew (*Sorex araneus*) in prepeak and peak years of population. *In Advances in the Biology of Shrews*. (Merritt, J. F., G. L. Kirkland Jr.

- and R. K. Rose, ed.). pp. 67-76, Carnegie Museum of Natural History, Pittsburgh.
- Nakano, S. and T. Furukawa-Tanaka. 1994. Intra- and interspecific dominance hierarchies and variation in foraging tactics of two species of stream-dwelling charrs. *Ecological Research*, 9: 9-20.
- Neet, C. R. and J. Hausser. 1990. Habitat selection in zones of parapatric contact between the common shrew *Sorex araneus* and Millet's shrew *S. coronatus*. *Journal of Animal Ecology*, 59: 235-250.
- Obara, Y. and N. Nara. 1984. Insectivores and myomorphs captured in and outside the Seikan-tunnel, in 1980—1983. (I) Distribution survey. *In* Report on the Specified Research in 1980—1983, College of Liberal Arts, Hirosaki University. ed.). Pp. 5-17, Hirosaki University, Hirosaki.
- Ohdachi, S. 1992. Home ranges of sympatric soricine shrews in Hokkaido, Japan. *Acta Theriologica*, 37: 91-101.
- Ohdachi, S. and K. Maekawa. 1990. Relative age, body weight, and reproductive condition in three species of *Sorex* (Soricidae; Mammalia) in Hokkaido. *The Research Bulletins of the College Experiment Forests, Faculty of Agriculture, Hokkaido University*, 47: 535-546.
- Ohta, K. 1970. The origin of the small mammalian fauna of Hokkaido (in Japanese). *Honyurui Kagaku (Mammalian Science)*, 20, 21: 179-198.
- Okhotina, M. V. 1974. Morpho-ecological features making possible joint habitation for shrews (*Sorex*, Insectivora)

- (in Russian). Fauna and Ecology of the Terrestrial Vertebrates in the Southern Part of the Soviet Far East (Vladivostok), 17: 42-57.
- Okhotina, M. V. 1991. Subspecies taxonomic prevision of Far East shrews (Insectivora, *Sorex*) with the description of new subspecies (in Russian with English summary). Proceedings of the Zoological Institute, USSR Academy of Science, 243: 58-70.
- Olsen, R. W. 1969. Agonistic behavior of the short-tailed shrew (*Blarina brevicauda*). Journal of Mammalogy, 50: 494-500.
- Paine, R. T. 1974. Intertidal community structure. Experimental studies on the relationship between a dominant competitor and its principal predator. Oecologia, 15: 93-120.
- Pernetta, J. C. 1977. Population ecology of British shrews in grassland. Acta Theriologica, 22: 279-296.
- Persson, L. 1985. Asymmetrical competition: are larger animals competitively superior? The American Naturalist, 126: 261-266.
- Persson, L. 1988. Asymmetries in competitive and predatory interactions in fish populations. In Size-structured Populations. (Ebenman, B. and L. Persson, ed.). Pp. 203-218, Springer-Verlag, Berlin.
- Platt, W. J. 1976. The social organization and territoriality of short-tailed shrew (*Blarina brevicauda*) population in old-field habitats. Animal Behaviour, 24: 305-318.

- Polis, G. A. and C. A. Myers. 1985. A survey of intraspecific predation among reptiles and amphibian. *Journal of Herpetology*, 19: 99-107.
- Rice, W. R. 1989. Analyzing tables of statistical tests. *Evolution*, 43: 223-225.
- Root, R. B. 1967. The niche exploitation pattern of the blue-gray gnatcatcher. *Ecological Monographs*, 37: 317-319.
- Rudge, M. R. 1968. The food of the common shrew *Sorex araneus* L. (Insectivora: Soricidae) in Britain. *Journal of Animal Ecology*, 37: 565-581.
- Ryan, J. M. 1986. Dietary overlap in sympatric population of pygmy shrews, *Sorex hoyi*, and masked shrews, *Sorex cinereus*, in Michigan. *Canadian Field-Naturalist*, 100: 225-228.
- Schluter, D. and R. E. Ricklefs. 1993a. Species diversity: an introduction to the problem. *In Species Diversity in Ecological Communities. Historical and Geographical Perspectives.* (Schluter, D. and R. E. Ricklefs, ed.). Pp. 1-10, The University of Chicago Press, Chicago.
- Schluter, D. and R. E. Ricklefs. 1993b. Convergence and the regional component of species diversity. *In Species Diversity in Ecological Communities. Historical and Geographical Perspectives.* (Ricklefs, R. E. and D. Schluter, ed.). Pp. 230-240, the University of Chicago Press, Chicago.
- Schneider, D. C. 1994. *Quantitative Ecology. Spatial and Temporal Scaling.* Academic Press, San Diego.

- Schoener, T. W. 1970. Non-synchronous spatial overlap of lizards in patchy habitats. *Ecology*, 51: 408-418.
- Schoener, T. W. 1975. Presence and absence of habitat shift in some widespread lizard species. *Ecological Monographs*, 45: 233-259.
- Schoener, T. W. 1983. Field experiments on interspecific competition. *The American Naturalist*, 122: 240-285.
- Sheftel, B. I. 1989. Long-term and seasonal dynamics of shrews in Central Siberia. *Annales Zoologici Fennici*, 26: 357-370.
- Sheftel, B. I. 1994. Spatial distribution on nine species of shrews in the central Siberian taiga. *In Advances in the Biology of Shrews*. (Merritt, J. F., G. L. Kirkland Jr. and R. K. Rose, ed.). pp. 45-56, Carnegie Museum of Natural History, Pittsburgh.
- Shillito (Babington), J. F. 1963. Observations on the range and movements of a woodland population of the common shrew *Sorex araneus* L. *Proceedings of the Zoological Society of London*, 140: 533-546.
- Shimada, M. 1986. Interspecific interaction and community structure (in Japanese). *Kotaigun-seitai Gakkai Kaihou* (Society of Population Ecology), 42: 1-12.
- Shimazaki, N. and H. Masatomi. 1986. Shrews in the moors near Naganuma in Sarobetsu plains, northern Hokkaido (in Japanese with English summary). *Wildlife Report* (Sapporo), 4: 49-56.

- Shirakawa, T. and K. Oikawa. 1988. An actograph sensing thermal radiation from animals. Proceedings of the 3rd Sapporo Symposium on Biological Rhythm, Sapporo.
- Shvarts, E. A. and D. V. Demin. 1994. Community organization of shrews in temperate zone forests of northwestern Russia. *In* Advances in the Biology of Shrews. (Merritt, J. F., G. L. Kirkland Jr. and R. K. Rose, ed.). pp. 57-67, Carnegie Museum of Natural History, Pittsburgh.
- Spencer, A. W. and D. Pettus. 1966. Habitat preference of five species of long-tailed shrews. *Ecology*, 47: 677-683.
- Stockley, P., J. B. Searle, D. W. Macdonald and C. S. Jones. 1994. Alternative reproductive tactics in male common shrews: relationships between mate-searching behaviour, sperm production, and reproductive success as revealed by DNA fingerprinting. *Behavioral Ecology and Sociobiology*, 34: 71-78.
- Stroganov, S. U. 1957. Mammals of Siberia. Insectivora (in Russian). Science Academy of USSR Press, Moscow.
- Strong, D. R., Jr. 1983. Natural variability and the manifold mechanisms of ecological communities. *The American Naturalist*, 122: 636-660.
- Voesenek, L. A. C. J. and A. C. Van Bommel. 1984. Intra and interspecific competition in the water shrew in the Netherlands. *Acta Theriologica*, 29: 297-301.
- Werner, E. E. and D. J. Hall. 1976. Niche shifts in sunfishes: experimental evidence and significance. *Science*, 191: 404-406.

- Whitaker, J. O., Jr. and T. W. French. 1984. Foods of six species of sympatric shrews from New Brunswick. *Canadian Journal of Zoology*, 62: 622-626.
- Whitaker, J. O., Jr. and R. E. Mumford. 1972. Food and ectoparasites of Indiana shrews. *Journal of Mammalogy*, 53: 329-335.
- Wiens, J. A., J. F. Addicott, T. J. Case and J. Diamond. 1986. Overview: the importance of spatial and temporal scale in ecological investigations. *In Community Ecology*. (Diamond, J. M. and T. J. Case, ed.). Pp. 145-153, Harper & Row, New York.
- Wrigley, R. E., J. E. Dubois and H. W. R. Copland. 1979. Habitat, abundance, and distribution of six species of shrews in Manitoba. *Journal of Mammalogy*, 60: 505-520.
- Yalden, D. W. 1981. The occurrence of the pigmy shrew *Sorex minutus* on moorland, and the implications for its presence in Ireland. *Journal of Zoology, London*, 195: 147-156.
- Yokohata, Y. 1990. Earthworm-capturing behavior of captive big-clawed shrew *Sorex unguiculatus* in wire mesh tunnels. *Journal of Mammalogical Society of Japan*, 15: 33-37.
- Yoneda, M. 1979. Study on the Population Dynamics of Rodents and Their Predators. Ph.D. dissertation, Hokkaido University.

Yoshino, H. and H. Abe. 1984. Comparative study on the foraging habits of two species of soricine shrews. *Acta Theriologica*, 29: 35-43.