



Title	Targeted sequence alteration of a chromosomal locus in mouse liver
Author(s)	Kamiya, Hiroyuki; Uchiyama, Masayuki; Piao, Jingshu et al.
Citation	International Journal of Pharmaceutics, 387(1-2), 180-183 https://doi.org/10.1016/j.ijpharm.2009.12.020
Issue Date	2010-03-15
Doc URL	https://hdl.handle.net/2115/42890
Type	journal article
File Information	IJP387-1-2_180-183.pdf



Targeted sequence alteration of a chromosomal locus in mouse liver

Hiroyuki Kamiya^{ab,*}, Masayuki Uchiyama^{ab}, Jingshu Piao^c, Yoshimichi Nakatsu^c,
Teruhisa Tsuzuki^c, and Hideyoshi Harashima^{ab}

*^aFaculty of Pharmaceutical Sciences, Hokkaido University, Kita-12, Nishi-6, Kita-ku,
Sapporo 060-0812, Japan*

^bCREST, Japan Science and Technology, Japan

*^cFaculty of Medical Sciences, Kyushu University, Maidashi-3-1-1, Higashi-ku, Fukuoka
812-8582, Japan*

*Corresponding author. Fax: +81-11-706-4879.

E-mail address: hirokam@pharm.hokudai.ac.jp (H. Kamiya)

Abstract

Targeted sequence alteration would be an attractive method in gene therapy and biotechnology. To achieve *in vivo* targeted sequence alteration, a tailed duplex DNA consisting of annealed 35mer and 794mer single-stranded DNAs was delivered by means of hydrodynamic tail vein injection into liver of transgenic mouse harboring a reporter gene (the *rpsL* gene) in its genome. The tailed DNA was designed for a conversion of ATC to AGC at codon 80 of the *rpsL* transgene. The anticipated T→G sequence alteration was induced in the transgene in the liver with an efficiency of ~0.1%. These results demonstrate the significant potential of this method for applications in gene therapy and biotechnology.

Keywords: Targeted sequence alteration; Gene correction; Tailed duplex DNA fragment; *rpsL* transgenic mouse; Hydrodynamic tail vein injection

1. Introduction

Targeted sequence alteration would provide a powerful tool for dissecting gene function and creating animal models that are deficient in genes of interest. Furthermore, a method for altering desired genomic DNA sequences in human somatic cells could lead to a gene therapy approach for diseases caused by genetic alterations (gene correction). For example, the dystrophin gene in Duchenne muscular dystrophy patients and the cystic fibrosis transmembrane conductance regulator gene in cystic fibrosis patients are potential targets of this technology (Gruenert et al., 2003). Targeted sequence conversion using oligonucleotides has been developed for introducing small sequence alterations including deletions, insertions, and base-substitutions into mammalian genomic DNA (Andersen et al., 2002; de Semir and Aran, 2006; Igoucheva et al., 2004; Parekh-Olmedo and Kmiec, 2007; Richardson et al., 2002; Seidman and Glazer, 2003). Small double-stranded DNA fragments have also been used to modify genomic DNA in both human and mouse cells (Gruenert et al., 2003; Sangiuolo, F. and Novelli, 2004). We recently found that a tailed duplex (TD) fragment, prepared by annealing an oligonucleotide to a several-hundred-base single-stranded (ss) DNA fragment, converted a target sequence in cultured mammalian cells with a higher efficiency than did a conventional double-stranded DNA fragment (Tsuchiya, et al., 2008). Thus, we attempted to use TD DNA for targeted sequence conversion in mice.

To monitor targeted sequence alteration at a chromosomal locus *in vivo*, we used a transgenic mouse harboring a reporter gene (the *Escherichia coli rpsL* gene) in its

genome (Fig. 1A). The *rpsL* transgenic mouse strains have been used to analyze spontaneous and carcinogen-induced mutagenesis in mice (Egashira et al., 2002; Gondo et al., 1996; Murai et al., 2000). Cells in the transgenic mice contain ~100 copies of the transgene in the chromosomal DNA, and the transgene is silent in mouse tissues due to lack of a eukaryotic promoter. The *rpsL* gene encodes the *E. coli* ribosomal protein S12. Specific mutations in this gene confer streptomycin resistance (*strA*) to *E. coli*. The wild-type *rpsL* gene is dominant, and its expression confers the streptomycin-sensitive phenotype. Thus, *E. coli strA* cells containing plasmids with either the wild-type or mutant *rpsL* genes exhibit the streptomycin-sensitive or -resistant phenotypes, respectively. Therefore, the frequency of sequence changes in the *rpsL* transgene can be easily determined from the frequency of streptomycin-resistant *E. coli* colonies obtained after introduction of mouse genome-derived plasmids carrying *rpsL* into an *E. coli strA* strain. We chose the ATC sequence at codon 80 of the *rpsL* transgene as a target site and designed the TD fragment to convert this codon to AGC.

In this study, we delivered naked TD fragment (Fig. 1B) into mouse liver by hydrodynamic tail vein injection (Liu et al., 1999; Zhang et al., 1999). This method enables the delivery of nucleic acids into the nuclei of liver cells without the use of any vehicles. It has been shown that ~40% of mouse liver cells expressed β -galactosidase when plasmid DNA encoding this enzyme was administered using this method (Liu et al., 1999). Thus, we might expect that the TD DNA could be delivered to at least ~40% of liver cells. We observed that the injection of the TD fragment induced the target

sequence alteration in the genomic DNA of mouse liver cells. These results demonstrate the significant potential of this method for applications in gene therapy and biotechnology.

2. Materials and methods

2.1. Preparation of DNA fragments for targeted mutagenesis

The *E. coli* JM105 strain harboring the phagemid DNA containing the sense strand of the mutant (AGC-80) *rpsL* gene was cultured overnight to obtain the ss phagemid DNA. The 794-base ss DNA fragment was obtained by annealing with their respective scaffold oligodeoxyribonucleotides (5'-dATCTTAAGAAATTCAGATCGAAG and 5'-dAACCGGGAATTCAGCGTC, Invitrogen Japan, Tokyo, Japan) containing an EcoRI site (underlined), followed by EcoRI digestion (4.5 U/ μ g of ss DNA) as described previously (Kamiya et al., 2008; Tsuchiya et al., 2005a). The ss DNA fragment was purified by low-melting point agarose gel electrophoresis and gel filtration chromatography. Its UV spectrum was measured to confirm its purity and to calculate the yield. The concentration was determined by the molar absorption coefficient of DNA: 1.0 OD₂₆₀ equals 40 μ g of ss DNA (Sambrook and Russell, 2001). The ss DNA fragment was mixed with a 10-fold molar excess amount of an oligonucleotide (5'-CAGATCGAAGTACTCAGTTTAAGCTGGCCTCCATG). The mixtures were heat-denatured at 98°C for 5 min and were immediately chilled on ice for at least 5 min.

They were then heated at 80°C for 5 min and cooled slowly to room temperature.

2.2. Hydrodynamics-based injection

The hydrodynamics-based injection was performed according to the method of Liu *et al.* (1999) and Zhang *et al.* (1999). The TD fragment (1000 µg as the ss DNA, 4.1 nmol), in 2 ml of saline, was injected into the *rpsL* transgenic mice (ssw2-14p with the C57BL/6J background) via the tail vein within 5 s.

2.3. Determination of sequence alteration efficiency

Mice were killed and the entire livers were harvested after 48 h. Sequence alteration efficiency in liver DNA was determined according to the methods described previously (Egashira *et al.*, 2002). Briefly, 15 µg of isolated genomic DNA was digested with BanII and the linearized DNA was treated with DNA ligase to circularize the pSSW plasmid (Fig. 1A). The DNA was purified by phenol and phenol–chloroform extractions, and subsequently precipitated with isopropanol. An aliquot of the DNA was introduced into DH10B *E. coli* cells by electroporation and the culture was plated onto LB agar plates containing 200 µg/ml of streptomycin and 50 µg/ml of kanamycin (selection plates) and LB agar plates containing 50 µg/ml of kanamycin (titer plates). The plates were incubated at 30°C, and the number of colonies on the selection plates was counted at 36–48 h. Frequencies of streptomycin-resistant colony-formation were calculated by dividing the number of streptomycin-resistant colonies on the selection plates by the

number of colonies on the titer plates. DNA fragments containing the *rpsL* gene were amplified by PCR from streptomycin-resistant colonies and sequencing reactions were conducted with an ABI PRISM BigDye Terminator Cycle Sequencing Kit and an ABI model 3130 DNA sequencer (Applied Biosystems, Foster City, CA).

3. Results

3.1. Administration of TD fragment induces targeted sequence alteration

The TD fragment, prepared by annealing of a 794-base ss *rpsL* DNA fragment with the AGC sequence and oligodeoxyribonucleotide complementary to the 3'-terminal region of the ss DNA (Fig. 1B), was administered by means of hydrodynamic tail vein injection (Liu et al., 1999; Zhang et al., 1999). Saline without DNA was injected into the control group. Two days after the administration, genomic DNA was isolated from the liver. The DNA after treatments with BanII and T4 DNA ligase was electroporated into *E. coli* DH10B (*strA*) cells, and streptomycin-resistant colonies were counted.

As shown in Fig. 2 and Table 1, treatment with the TD fragment drastically increased the number of *E. coli* colonies grown on agar plates containing streptomycin. The frequencies of streptomycin-resistant colony-formation of the control group treated with saline were $0.98 - 1.93 \times 10^{-5}$. These values are similar to spontaneous mutation frequencies in *rpsL* in transgenic mice (Murai et al., 2000), suggesting that the hydrodynamics-based administration itself did not induce sequence alterations in the

mouse genomic DNA. In contrast, mice that received the TD fragment showed a marked increase in frequency of streptomycin-resistant *E. coli* colony-formation. The average frequency of the three treated mice (101×10^{-5}) was two orders of magnitude higher than that of the control mice.

To exclude the possibility that the sequence alteration observed in this study might occur in bacteria, we performed an additional control experiment. When 15 μ g of the TD fragment and 15 μ g of the liver genomic DNA from a mouse in the control group were mixed, treated with BanII and DNA ligase, and introduced into *E. coli*, no increase in the frequency of streptomycin-resistant colonies was found (data not shown). The ratio of 1:1 by weight corresponds to the situation where 45% of the administered TD fragments persist in the liver in the intact form, and are fully recovered with genomic DNA. No “targeted sequence alteration” was observed even under these conditions, thus excluding the possibility of the occurrences of TD-induced targeted sequence alteration in bacteria.

3.2. Actual sequence alteration efficiency

The increased formation of streptomycin-resistant *E. coli* colonies could be due to the induction of the expected site-specific sequence alteration or to unexpected mutations elicited by the administration of the TD fragment. To discriminate between these two possibilities, we analyzed the sequence of the *rpsL* gene in the streptomycin-resistant colonies in both the control and the TD groups.

No colonies carried the T→G sequence alteration at codon 80 of the *rpsL* gene in the control group (data not shown). Thus, no “targeted” sequence alteration occurred spontaneously in the four mice in this group. Conversely, the expected sequence change was detected in all of the mice of the TD group (Fig. 2C). The targeted sequence alterations were detected with frequencies of 86 – 97% in the colonies derived from the mice in the TD group (Table 2). Therefore, the actual sequence alteration efficiencies were calculated to be $28 - 165 \times 10^{-5}$ (0.028 – 0.165%).

3.3. Unexpected mutations in the *rpsL* gene

Of 117 streptomycin-resistant colonies obtained by transfection of the plasmids derived from the mice in the TD group, 11 contained the *rpsL* gene with an unexpected mutation. Fig. 3 shows the overall distribution of the unexpected mutations. Of these unexpected mutations, eight were large deletions (≥ 5 bp). Such deletions were not detected in the saline group (data not shown). Furthermore, large deletions have never been detected at such high frequencies ($0.5 - 1.0 \times 10^4$) in previous studies analyzing spontaneous mutagenesis with *rpsL* transgenic mice (Murai et al., 2000). These results suggest that these large deletions might be caused by the administration of the TD fragment.

4. Discussion

The TD fragment was shown to have the ability to alter a target sequence more

efficiently than double-stranded DNA fragments in cultured mammalian cells (Tsuchiya et al., 2008). In this study, we showed that the TD fragment, when delivered by hydrodynamic tail vein injection, induced the targeted gene alteration in the genomic DNA of mouse liver cells. Thus, TD would be a useful nucleic acid for *in vivo* sequence change.

The hydrodynamic tail vein injection method is known as one of the most efficient methods for transgene expression *in vivo* (Kobayashi et al., 2005). The efficient transgene expression is due to effective delivery into hepatocytes (Liu et al., 1999), although activation of transgene by this injection procedure itself is another reason (Ochiai et al., 2007; Nishikawa et al., 2008). Moreover, efforts have been made toward establishing a hydrodynamic procedure for clinical use (Suda and Liu, 2007). In this study, we evaluated a potential of the TD fragment for the *in vivo* targeted gene alteration using this delivery method.

The targeted gene alteration occurred in mouse liver albeit at a low frequency (0.165% at most, Table 2). We used *rpsL* transgenic mice and chose a chromosomal transgene in their liver cells as a target gene. The use of this experimental system enabled highly sensitive and quantitative detection of a targeted sequence alteration in animal tissue. Another advantage of this system is that unexpected (untargeted) sequence changes within the gene were also detectable. However, this transgene, which lacks a eukaryotic promoter, might be located in a heterochromatic region where DNA is tightly packed and, therefore, is less accessible to a putative complex containing TD, although

recombination that could be the sequence conversion pathway is not completely suppressed in the heterochromatic region (Williams and Robbins, 1992). Thus, a higher frequency of targeted sequence alteration might be achieved in actively transcribed genes. In addition, the frequency of targeted sequence alteration might be improved by modifying the method that we used in this study, such as repeated administration of the TD fragment and protection of the TD fragment from nucleases with cationic compounds. Moreover, nuclear localization signal peptides could be conjugated to the oligonucleotide to enhance nuclear entry of the TD fragment. Furthermore, tissue-selective delivery of the TD fragment, by conjugation of targeting molecules to TD or by use of targeting carriers, would achieve sequence alteration in tissues other than liver. Many factors may affect the sequence alteration efficiency, and further efforts including mechanistic studies are warranted.

In this study, genomic DNA was isolated from the liver two days after the administration. In the case of naked plasmid DNA delivered by the hydrodynamic tail vein injection, most of the delivered DNA was degraded within two days (Ochiai et al., 2006). Thus, TD fragment delivered in the naked form would also be fragmented within two days. In addition, sequence conversion was complete in cultured cells at 36 h after the introduction of ss DNA fragment complexed with cationic lipids (Tsuchiya et al., 2005b), suggesting that amount of TD was decreased to lower level than that required for the conversion at 36 h even when delivered in the complexed form. Thus, the time point when we isolated genomic DNA (two days after the administration) seemed

enough for the conversion by the naked TD fragment.

Unexpectedly, untargeted mutations, mainly large deletions, appeared to be caused by the administration of the TD fragment (Fig. 3). Molecular mechanism(s) of the untargeted mutations as well as that/those of the targeted sequence conversion are unknown. Mechanistic studies are required to suppress the side effects for future clinical use of TD.

In conclusion, we showed that a TD fragment can induce an *in vivo* targeted sequence alteration in mouse chromosomal DNA. This study provides the evidence of *in vivo* targeted gene alteration by systemic delivery of nucleic acid. These results demonstrate the significant potential of this method for applications in gene therapy and biotechnology.

Acknowledgements

This work was supported in part by Grants-in-Aid from the Ministry of Education, Culture, Sports, Science and Technology of Japan and from the Japan Society for the Promotion of Science.

References

- Andersen, M. S., Sorensen, C. B., Bolund, L., Jensen, T. G., 2002. Mechanisms underlying targeted gene correction using chimeric RNA/DNA and single-stranded DNA oligonucleotides. *J. Mol. Med.* 80, 770-781.
- de Semir, D., Aran, J. M., 2006. Targeted gene repair: the ups and downs of a promising gene therapy approach. *Curr. Gene Ther.* 6, 481-504.
- Egashira, A., Yamauchi, K., Yoshiyama, K., Kawate, H., Katsuki, M., Sekiguchi, M., Sugimachi, K., Maki, H., Tsuzuki, T., 2002. Mutational specificity of mice defective in the MTH1 and/or the MSH2 genes. *DNA Repair* 1, 881-893.
- Gondo, Y., Shioyama, Y., Nakao, K., Katsuki, M., 1996. A novel positive detection system of in vivo mutations in *rpsL (strA)* transgenic mice. *Mutat. Res.* 360, 1-14.
- Gruenert, D. C., Bruscia, E., Novelli, G., Colosimo, A., Dallapiccola, B., Sangiuolo, F., Goncz, K.K., 2003. Sequence-specific modification of genomic DNA by small DNA fragments. *J. Clin. Invest.* 112, 637-641.
- Igoucheva, O., Alexeev, V., Yoon, K., 2004. Oligonucleotide-directed mutagenesis and targeted gene correction: a mechanistic point of view. *Curr. Mol. Med.*,4, 445-463.
- Kamiya, H., Uchiyama, M., Nakatsu, Y., Tsuzuki, T., Harashima, H., 2008. Effects of target sequence and sense versus antisense strands on gene correction with single-stranded DNA fragments. *J. Biochem.* 144, 431-436.
- Kobayashi, N., Nishikawa, M., Takakura, Y., 2005. The hydrodynamics-based procedure for controlling the pharmacokinetics of gene medicines at whole body,

- organ and cellular levels, *Adv. Drug Deliv. Rev.* 57, 713–731.
- Liu, F., Song, Y., Liu, D., 1999. Hydrodynamics-based transfection in animals by systemic administration of plasmid DNA. *Gene Ther.* 6, 1258-1266.
- Murai, H., Takeuchi, S., Nakatsu, Y., Ichikawa, M., Yoshino, M., Gondo, Y., Motoya Katsuki, M., Tanaka, K., 2000. Studies of *in vivo* mutations in *rpsL* transgene in UVB-irradiated epidermis of XPA-deficient mice. *Mutat. Res.* 450, 181-192.
- Nishikawa, M., Nakayama, A., Takahashi, Y., Fukuhara, Y., Takakura, Y., 2008. Reactivation of silenced transgene expression in mouse liver by rapid, large-volume injection of isotonic solution, *Hum. Gene Ther.* 19, 1009-1020.
- Ochiai, H., Harashima, H., Kamiya H., 2006. Intranuclear disposition of exogenous DNA *in vivo*: silencing, methylation and fragmentation. *FEBS Lett.* 580, 918-922.
- Ochiai, H., Fujimuro, M., Yokosawa, H., Harashima, H., Kamiya, H., 2007. Transient activation of transgene expression by hydrodynamics-based injection may cause rapid decrease in plasmid DNA expression, *Gene Ther.* 14, 1152-1159.
- Parekh-Olmedo, H., Kmiec, E. B., 2007. Progress and prospects: targeted gene alteration (TGA). *Gene Ther.* 14, 1675–1680.
- Richardson, P. D., Augustin, L. B., Kren, B. T., Steer, C.J., 2002. Gene repair and transposon-mediated gene therapy. *Stem Cells* 20, 105-118.
- Sambrook, J., Russell, D. W., 2001. *Molecular Cloning* 3rd ed., Cold Spring Harbor Laboratory Press, Plainview, New York.
- Sanguolo, F., Novelli, G., 2004. Sequence-specific modification of mouse genomic

- DNA mediated by gene targeting techniques. *Cytogenet. Genome Res.* 105, 435-441.
- Seidman, M. M., Glazer, P. M., 2003. The potential for gene repair via triple helix formation. *J. Clin. Invest.* 112, 487-494.
- Suda, T., Liu, D., 2007. Hydrodynamic gene delivery: its principles and applications. *Mol. Ther.* 15, 2063-2069.
- Tsuchiya, H., Harashima, H., Kamiya, H., 2005a. Increased SFHR gene correction efficiency with sense single-stranded DNA. *J. Gene Med.* 7, 486-493.
- Tsuchiya, H., Harashima, H., Kamiya, H., 2005b. Factors affecting SFHR gene correction efficiency with single-stranded DNA fragment. *Biochem. Biophys. Res. Commun.* 336, 1194-1200.
- Tsuchiya, H., Uchiyama, M., Hara, K., Nakatsu, Y., Tsuzuki, T., Inoue, H., Harashima, H., Kamiya, H., 2008. Improved gene correction efficiency with a tailed duplex DNA fragment. *Biochemistry* 47, 8754-8759.
- Williams, S. M., Robbins, L. G., 1992. Molecular genetic analysis of *Drosophila* rDNA arrays. *Trends Genet.* 8, 335-340.
- Zhang, G., Budker, V., Wolff, J. A., 1999. High levels of foreign gene expression in hepatocytes after tail vein injections of naked plasmid DNA. *Hum. Gene Ther.* 10, 1735-1737.

Figure Legends

Figure 1 Structures of (A) the pSSW plasmid containing the *rpsL* gene, integrated into genomic DNA of transgenic mice, and (B) the TD fragment and the region near the *rpsL* gene in the genomic DNA. (A) Cells in the transgenic mice contain ~100 copies of the transgene in the chromosomal DNA. *kan^r*, *E. coli* kanamycin resistance gene; *ori*, replication origin of the plasmid. (B) The TD fragment consisted of annealed 35mer and 794mer ss DNAs. The circle on the 794mer DNA represents the position corresponding codon 80. The *rpsL* promoter that works in *E. coli* cells is also shown (the arrow).

Figure 2 Sequence alteration in mouse liver. (A and B) Streptomycin-resistant *E. coli* colonies derived from genomic DNA of *rpsL* transgenic mice in the (A) control and (B) TD groups. (C) Sequence analysis of the *rpsL* gene of pSSW in the streptomycin-resistant colony derived from a mouse in the TD group (left: wild-type sequence, right: altered sequence). Codon 80 is underlined.

Figure 3 The overall distribution of the unexpected mutations detected in the *rpsL* gene from the TD-administered mice. The sense strand sequence is shown. The symbol Δ represents a single-base deletion. Large deletions corresponding to loss of most of the gene were found in two cases (not shown). Codon 80 is underlined.

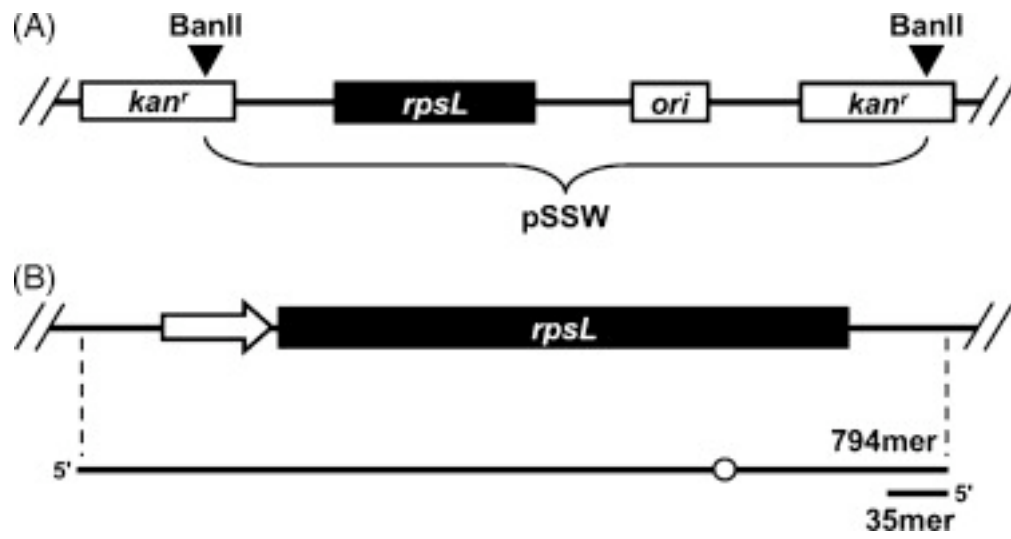

Fig. 1

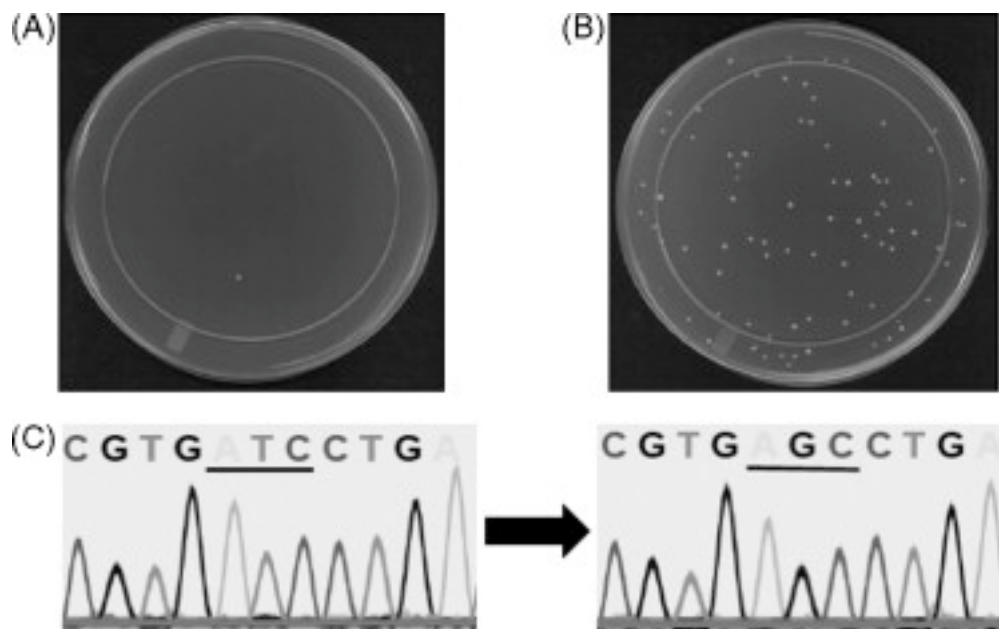

Fig. 2

ATGGCAACAG TTAACCAGCT GGTACGCAA^Δ CCACGTGCTC GCAAAGTTGC GAAAAGCAAC GTGCCTGCGC
 TGGAAGCATG CCCGCAA^Δ CGTGGCGTAT GTACTCGTGT ATATACTACC ACTCCTAAAA AACCGAACTC
 CGCGCTGCGT AAAGTATGCC^A GTGTTCGTCT GACTAACGGT TTCGAAGTGA CTCCTACAT CGGTGGTGAA
 GGTCACAACC TGCAGGAGCA CTCCGTG^{ATC} CTGATCCGTG GCGGTCGTGT TAAAGACCTC CCGGGTGTC
 GTTACCACAC CGTACGTGGT GCGCTTGACT GCTCCGGCGT TAAAGACCGT AAGCAGGCTC GTTCCAAGTA
 TGGCGTGAAG CGTCCTAAGG CTAA

← 5-bp deletion
 ← 5-bp deletion
 ↗ large deletion
 ↗ large deletion
 ↗ large deletion

Fig. 3

Table 1
Frequencies of streptomycin-resistant colony.

Group	Mouse no.	Age (week)	Sex	Weight (g)	Frequency of resistant colony ($\times 10^{-5}$)
Saline	1	4	M	19.1	0.98
	2	8	M	23.1	1.76
	3	11	M	25.1	1.27
	4	12	F	20.1	1.93
TD	1	4	M	17.0	32.1
	2	5	F	14.0	100
	3	6	M	15.6	170

Table 2
Actual targeted sequence alteration efficiencies of the TD group.

Mouse no.	No of colonies		Sequence alteration efficiency ($\times 10^{-5}$) ^a
	Sequenced	Possessing AGC sequence	
1	35	30	27.5
2	48	43	89.6
3	34	33	165

^a The values were obtained by multiplying the ratios of numbers of colonies possessing the AGC sequence at codon 80 to those sequenced by the frequencies of streptomycin-resistant colonies shown in Table 1.