



HOKKAIDO UNIVERSITY

Title	Nitrogen budget and relationships with riverine nitrogen exports of a dairy cattle farming catchment in eastern Hokkaido, Japan
Author(s)	Hayakawa, Atsushi; Woli, Krishna Prasad; Shimizu, Mariko et al.
Citation	Soil Science & Plant Nutrition, 55(6), 800-819 https://doi.org/10.1111/j.1747-0765.2009.00421.x
Issue Date	2009-12
Doc URL	https://hdl.handle.net/2115/44306
Rights	The definitive version is available at www.blackwellsynergy.com
Type	journal article
File Information	SSP55-6_800-819.pdf



1 **Title:** The nitrogen budget and relationships with riverine nitrogen exports of a dairy cattle
2 farming catchment in eastern Hokkaido, Japan

3 **Authors:** Atsushi HAYAKAWA^{1,2}, Krishna Prasad WOLI^{2,3}, Mariko SHIMIZU², Koji
4 NOMARU^{2,4}, Kanta KURAMOCHI², and Ryusuke HATANO²

5 1. Department of Biological Environment, Faculty of Bioresource Science, Akita

6 Prefectural University, Akita, 010-0195, Japan

7 2. Laboratory of Soil Science, Graduate School of Agriculture, Hokkaido University,

8 Sapporo 060-8589, Japan

9 3. Department of Natural Resources and Environmental Sciences, University of

10 Illinois, Urbana-Champaign 61801 IL, USA

11 4. Integrated Center for Science Shigenobu Station, Ehime University, Toon, Ehime

12 791-0295, Japan

13 **Corresponding author:**

14 Name: Atsushi Hayakawa

15 Telephone number: +81-18-872-1623

16 Fax number: +81-18-872-1677

17 E-mail address: hayakawa@akita-pu.ac.jp

18 Department of Biological Environment, Faculty of Bioresource Science, Akita

19 Prefectural University, Akita 010-0195, Japan

20 **Type of contribution:** Full-length paper

21 **Division of the manuscript:** Environment

22 **Short running title:** N budgets and export from dairy farming catchments

1 Abstract

2 Dairy farming regions are important contributors of nitrogen (N) to surface waters. We
3 evaluated the N budget and relationships to riverine N exports within the Shibetsu River
4 catchment (SRC) of a dairy farming area in eastern Hokkaido, Japan. Five drainage basins
5 with variable land cover proportions within the SRC were also evaluated individually. We
6 quantified the net N input (NNI) to the catchment from the difference between the input
7 (atmospheric deposition, chemical fertilizers, N fixation by crops, and imported food and feed)
8 and the output (exported food and feed, ΔS_{liv} and ΔS_{hu} that are differences between input and
9 output in livestock and human biomass, respectively) using statistical and measured data.
10 Volatilized ammonia (NH_3) was assumed to be recycled within the catchment. The riverine
11 export of N was quantified. Agricultural N was a dominant source of N to the SRC. Imported
12 feed was the largest input ($38.1 \text{ kg N ha}^{-1} \text{ yr}^{-1}$), accounting for 44% of total inputs, followed by
13 chemical fertilizers ($32.4 \text{ kg N ha}^{-1} \text{ yr}^{-1}$) and N fixation by crops ($13.4 \text{ kg N ha}^{-1} \text{ yr}^{-1}$). The
14 exported food and feed was $24.7 \text{ kg N ha}^{-1} \text{ yr}^{-1}$, and the ΔS_{liv} and ΔS_{hu} was 7.6 and 0.0 kg N
15 $\text{ha}^{-1} \text{ yr}^{-1}$, respectively. As a result, the NNI amounted to $54.6 \text{ kg N ha}^{-1} \text{ yr}^{-1}$. The riverine export
16 of TN from the five drainage basins correlated well with the NNI, accounting for 27% of the
17 NNI. The fate of the missing NNI that was not measured as riverine export could possibly
18 have been denitrified and/or retained within the SRC. A change in the estimate of the
19 deposition-rate of volatilized NH_3 from 100 to 0% redeposited would have decreased NNI by
20 37%, although we show that most NH_3 was likely redeposited. This study demonstrated that
21 the focus should be on controlling agricultural N to reduce the impact of environmental
22 pollution as well as on evaluating denitrification, N stocks in soil, and the fate of NH_3
23 volatilization in the SRC.

1
2
3
4
5
6
7
8
9
10
11
12
13
14
15
16
17
18
19
20
21
22
23
24
25
26
27
28
29
30
31
32
33
34
35
36
37
38
39
40
41
42
43
44
45
46
47
48
49
50
51
52
53
54
55
56
57
58
59
60

1

2 **Key words:** catchment, dairy farming, grassland, nitrogen budget, nitrogen export.

For review

1 INTRODUCTION

2 Human activities have greatly altered the N cycle by accelerating the rate of
3 anthropogenic N fixation in landscapes (Vitousek *et al.* 1997; Galloway and Cowling 2002).
4 Greater reactive N has enabled us to increase crop production. However, it could also lead to
5 eutrophication of surface water, causing degradation of aquatic ecosystems and problems such
6 as toxic algal blooms, loss of oxygen, depletion of the fish population, and loss of biodiversity
7 (Carpenter *et al.* 1998). Understanding the sources of N loading is essential to the
8 development of nutrient-management strategies in landscapes (Boyer *et al.* 2002). However,
9 non-point sources of pollution are difficult to quantify since they generally encompass large
10 areas in drainage basins and involve complex biotic and abiotic interactions in comparison to
11 point sources of pollution (Carpenter *et al.* 1998).

12 It is generally found that inputs of N to terrestrial systems exceed riverine export from
13 large watersheds (Howarth *et al.* 1996; David and Gentry 2000; Boyer *et al.* 2002, 2006).
14 Howarth *et al.* (1996) reported that the net anthropogenic N input (NANI; the sum of
15 atmospheric deposition, application of chemical fertilizer, N fixation by leguminous crops, and
16 the net input of food and feed) and riverine TN export correlated significantly, and 20% of the
17 NANI was exported through the rivers entering the North Atlantic Ocean. Boyer *et al.* (2002)
18 also reported that 25% of the net N input (NNI) was exported from 16 major watersheds in the
19 northeastern U.S.A. These studies clearly indicated either a surplus of N or missing N in mass
20 balance. The fate of this residual N is supposed to be either lost to the atmosphere by
21 denitrification or stocked in soils and woody biomass (Howarth *et al.* 1996; Van Breemen *et al.*
22 2002). On the other hand, McIsaac and Hu (2004) reported that the riverine N export was
23 approximately 100% of NANI in the intensive tile drain watershed. Borbor-Cordova *et al.*

1 (2006) reported that the total dissolved N export correlated with N input, but some watersheds
2 showed a negative balance, indicating a loss of soil fertility. Although this type of N mass
3 balance approach is subject to many assumptions and limitations in the available data, the
4 analysis indicates possible areas for further study and measurements to reduce errors in
5 estimating important fluxes (David and Gentry 2000) and also highlights how human
6 activities affect N cycling in the region (Boyer *et al.* 2002).

7 Japan is a large net importer of food and feed. The food self-sufficiency is only 40%
8 based on calories (General Food Policy Bureau, Ministry of Agriculture, Forestry and
9 Fisheries 2004), and the feed self-sufficiency in livestock husbandry is only 25% based on
10 total digestible nutrients (Statistics Department, Ministry of Agriculture, Forestry and
11 Fisheries 2003). As a result, a large amount of animal excreta is generated every year in Japan,
12 accounting for 159 kg N ha⁻¹ yr⁻¹ per unit of cultivated area in 1999. This quantity was larger
13 than the application rate of chemical fertilizer, which decreased from 145 kg ha⁻¹ yr⁻¹ in 1974
14 to 104 kg N ha⁻¹ yr⁻¹ in 1999 (Nishio 2002). Mishima (2001) reported that unused or disposed
15 manure increased up to 39 kg N ha⁻¹ yr⁻¹ per unit of cultivated area in 1997. Nitrogen
16 concentrations in ground water predicted by N mass balance and precipitation were high in
17 various prefectures where a large amount of animal excreta was generated (Hojito *et al.* 2003).

18 The 'Konsen' region of eastern Hokkaido is the largest dairy farming region in Japan.
19 Milk production in this region accounted for 15.7% of the country in 2003 (Statistics
20 Department, Ministry of Agriculture, Forestry and Fisheries 2003, Hokkaido Statistics and
21 Information Office 2003). Previous studies conducted in the Shibetsu River catchment (SRC)
22 showed that the concentration of stream NO₃⁻-N was correlated with the proportion of upland
23 area of the agricultural catchment (Woli *et al.* 2004; Hayakawa *et al.* 2006). This indicates that

1 the type of land use and N management on a field and/or farm may influence on the riverine N
2 export. However, the relationship between N budgets and riverine N export from this region is
3 still unknown. The objective of this study was to evaluate the present N budget and its
4 relationship with riverine N exports from five drainage basins in the SRC.

5 MATERIALS AND METHODS

6 Site description

7 The Shibetsu River catchment (drainage basin 'A' as illustrated in Fig. 1; lat. 43.634N,
8 long. 145.085E) in eastern Hokkaido, Japan was selected for this study. The catchment area is
9 679 km². This region has a hemi-boreal climate, characterized by warm summers and cold
10 winters. Precipitation averages 1147 mm yr⁻¹ and the annual mean temperature is 5°C, with
11 the lowest mean monthly temperature in February (-8.3°C) and the highest mean monthly
12 temperature in August (18.0°C) (1978-2002 average, Japan Meteorological Agency 2007).
13 The average maximum snow depth during the winter is 73 cm. Andisols are the main soil type
14 in the catchment and Gray Lowland Soils and Peat Soils exist in the lowlands surrounding the
15 Shibetsu River. Most of the wetlands located at the lower part of the Shibetsu River have
16 disappeared; and the remaining 2 km² area of wetland is the result of river improvement work
17 accompanied by the change in land use from wetlands to grasslands (Tachibana *et al.* 1997;
18 Nakamura 2003). The Nakashibetsu town, covering most of the SRC, has a large grassland
19 area, and dairy farming is a main occupation. Grassland (*Phleum pratense*) occupies more
20 than 95% of the agricultural land area, and the remaining is cultivated with maize (*Zea mays*
21 L.), sugar beet (*Saccharum officinarum*), potato (*Solanum tuberosum*), and Japanese radishes
22 (*Raphanus sativus* Linn.). There is a large shelterbelt of lattice (Japanese larch-*Larix*
23 *kaempferi*) forest with 180 m width surrounding the grassland in the SRC (Fig. 1). The human

1 population was estimated at 24000 persons in 2003 (35 people km⁻²) concentrated in the
2 middle part of the catchment (the urban area is illustrated in Fig. 1).

3 **Selection of drainage basins**

4 We selected five drainage basins, 'A', 'B', 'C', 'D', and 'E', with various proportions of
5 upland area in the SRC (Fig. 1, Table 1). The area corresponding to each major type of land
6 use (e.g. upland, forests, urban, and wasteland) in the drainage basins of each monitoring
7 station was estimated by dividing the respective drainage basins into a square mesh of 4 × 4
8 mm² on 1:25000 topographic maps (1 cell is thus equivalent to 1 ha). For monitoring stations
9 in the lower reaches of a stream, the drainage basins were determined by including the
10 drainage basins of all upper streams and tributaries that flow into it (Woli *et al.* 2004).

11 Sampling of river water and atmospheric DIN deposition, and monitoring of river water level
12 were conducted at each monitoring station. The area of upland crops and that of grasslands is
13 defined as 'upland' in this study. The drainage basin 'A' has the largest drainage area
14 containing 'B', 'C', 'D', and 'E' drainage basins. The basin 'E' is the forest area. The mean of
15 river runoff at drainage basin 'A' is 1085 mm yr⁻¹ and the mean of runoff ratio
16 (runoff/precipitation) is 91% (Ministry of Land, Infrastructure and Transport, Japan 2007).

17 **Estimation of the NNI and internal N budgets, and measuring riverine N exports**

18 We developed an N budget model (Fig. 2) based on a previous model (Nagumo and
19 Hatano 1999) by combining land use, meteorological, demographic, and agricultural data
20 obtained from census, literature, and web sites. The riverine N exports were measured in the
21 five drainage basins. Both the N budgets and riverine N export were estimated for 2003 and
22 2004. We estimated net N inputs (NNI) for each of the drainage basins by referring to the
23 methods described in previous studies (Howarth *et al.* 1996; Boyer *et al.* 2002) and described

1 as (unit: kg N ha⁻¹ of drainage area yr⁻¹):

$$2$$

$$3 \quad NNI = N_{chem} + N_{fix} + N_{dep} + N_{imfe} + N_{imfo} - N_{exp} - N_{exp_am} - \Delta S_{liv} - \Delta S_{hu} \quad (1)$$

$$4$$

5 where N_{chem} is the chemical N fertilizer, N_{fix} is the agricultural N fixation by leguminous and
 6 non-leguminous crops, N_{dep} is dissolved inorganic N (DIN) deposition, N_{imfe} is imported feed,
 7 N_{imfo} is imported food, N_{exp} is exported food and feed, N_{exp_am} is exported NH₃ from a
 8 catchment, and ΔS_{liv} and ΔS_{hu} are differences between input and output in livestock and human
 9 bodies, respectively. The estimation methods of these variables are described below.

10 ***Inputs from chemical fertilizer***

11 The amount of chemical N fertilizer was calculated by multiplying the rate of fertilizer
 12 application by land area cultivated for each crop. For grasslands, the rate of fertilizer
 13 application was 63 kg N ha⁻¹ yr⁻¹ obtained from a questionnaire survey (Hokkaido Agricultural
 14 Experiment Station, Tenpoku and Konsen Branches 2000) of 175 households conducted in the
 15 Shibetsu region from 1997 to 1999. For other land uses, the rates of fertilizer application for
 16 sugar beets, maize, potatoes, and Japanese radishes (150, 130, 70, and 60 kg N ha⁻¹ yr⁻¹,
 17 respectively) were used as recommended by the Hokkaido Fertilizer Application Guideline
 18 (Hokkaido Department for Agro-policy 2002).

19 There might be uncertainties in the amount of fertilizer use because the values were not
 20 based on actual sales data. We believe that the reliability of the amount of fertilizer input to
 21 grassland is comparatively high since this information was obtained from a questionnaire
 22 survey conducted in this region. However, there might be limitations in the local
 23 recommendations, which were used for other land uses, because there was no empirical

1
2
3
4 1 evidence suggesting that the actual fertilizer applications were consistent with the local
5
6 2 recommendations in this area. We thought that any error would be of minor consequence due
7
8
9 3 to a low magnitude of fertilizer inputs (5% of the total fertilizer N input in 2003) to land uses
10
11 4 other than grassland.

12 13 14 5 ***Inputs from agricultural N fixation by crops***

15
16
17 6 Agricultural N fixation by leguminous and non-leguminous crops was calculated using
18
19 7 literature values. The N fixation rate in the grasslands was estimated by multiplying a
20
21
22 8 leguminous crop ratio per unit of cultivated area by a factor of 3 (Taube *et al.* 1996). The
23
24 9 average leguminous crop ratio in the grasslands was reported as 9% in this region (Hokkaido
25
26
27 10 Agricultural Experiment Station, Tenpoku and Konsen Branches 2000); therefore the fixation
28
29
30 11 rate was calculated as 27 kg N ha⁻¹ yr⁻¹. For other agricultural crops, the fixation rate of 5 kg N
31
32 12 ha⁻¹ yr⁻¹ was used (Yoshida, 1981).

33 34 35 13 ***Inputs from atmospheric deposition***

36
37
38 14 The atmospheric DIN (NO₃⁻-N and NH₄⁺-N) deposition was calculated by multiplying
39
40 15 the water-weighted DIN concentration by the annual precipitation. The DIN deposition was
41
42
43 16 monitored at five stations for eight months (April-November) in 2003 and 2004. The bulk
44
45
46 17 sample was collected by a 300 mm diameter funnel connected with the 18 L polyethylene tank.
47
48 18 The height of the funnel was set as 1.5 m. The total precipitation for this period accounted for
49
50
51 19 83% of the annual precipitation in this region (Japan Meteorological Agency 2007). The mean
52
53 20 DIN deposition at the five stations in 2003 and 2004 were 2.2±1.3, 1.6±1.1 kg N ha⁻¹ yr⁻¹,
54
55
56 21 respectively. The NH₄⁺-N / DIN ratios in 2003 and 2004 were 70 ± 7.9, 52 ± 28%,
57
58 22 respectively.

59
60
23 In this study, the entire DIN deposition measured at the five stations was assumed to be

1 from outside the SRC. Monitoring stations for assessing DIN deposition were generally
2 located in forest areas rather than in farms, animal feedlots, or grasslands, and therefore the
3 measured DIN was supposed to be a long-range transport from outside the SRC.

4 ***Exported NH₃ from a catchment***

5 The export of volatilized NH₃ from a catchment was estimated by an equation described
6 below:

$$7 \quad N_{exp_am} = N_{am} (1 - \alpha) \quad (2)$$

8 where N_{am} is volatilized NH₃ within a catchment, α (0-100%) is a re-deposition ratio of
9 volatilized NH₃ to a catchment as described below:

$$10 \quad \alpha = N_{dep_am} / N_{am} \quad (3)$$

11 where N_{dep_am} is a re-deposition of volatilized NH₃. In this study, all the volatilized NH₃ within
12 the SRC was treated as being recycled that was re-deposited into the uplands (Fig. 2) because
13 the volatilized NH₃ is likely to be re-deposited near the site from which it was generated
14 (Hojito *et al.* 2006). Since α is 100% in this case, N_{exp_am} is assumed to be zero.

15 ***Inputs through transfer of food and feed***

16 As the livestock excreta and human waste are supposed to be recycled within the region
17 and are thus not considered as new inputs, these terms are included in the estimation of N as
18 part of the net import of food and feed as recommended by Boyer *et al.* (2002). The net import
19 of food and feed was calculated by the difference between import and export of food and feed.

1 We estimated the import and export of food and feed within the catchment by calculating
2 various components related to human and livestock subsystems as described below.

3 We calculated the rates of human N demand based on dietary intake of N derived from a
4 literature value. Human N demand was 3.14 kg N person⁻¹ yr⁻¹, which was divided into
5 excretion (2.61 kg N person⁻¹ yr⁻¹) and sewage (0.53 kg N person⁻¹ yr⁻¹) (Kunimatsu and
6 Muraoka 1997). The self-supported food was estimated assuming that the self-sufficiency rate
7 of the farmer's food was 37% of the total N demand and that of non-farmers was 0% in
8 Hokkaido (Nagumo 2000). The imported food was calculated as the difference between
9 human N demand and self-supported food. The difference between input and output (ΔS_{hu})
10 was calculated as zero since the total input (N demand) and the output (N excretion and
11 sewage) for human bodies were the same in this case. The ΔS_{hu} is described as follows:

$$\Delta S_{hu} = N_{selfo} + N_{imfo} - N_{sew} \quad (4)$$

12
13 where N_{selfo} is self-supported food, N_{imfo} is imported food, and N_{sew} is human-excreted and
14 sewage N.

15
16
17 Nitrogen content in harvested crops and residues was estimated from agricultural census
18 data of the catchment and literature values (Table 2). Crop yields were obtained from statistics
19 of Nakashibetsu town (Hokkaido Statistics and Information Office 2004, 2005). Protein and
20 moisture contents of harvested crops and residues were obtained from literatures (Hokkaido
21 Agricultural Experiment Station, Tenpoku and Konsen Branches 2000; Resources Council,
22 STA 1982; Agriculture, Forestry and Fisheries Research Council Secretariat, MAFF 1995).
23 Nitrogen concentration in harvested crops and residues were calculated using the protein

1 content and the mass ratio of N to protein (1:6.25). The N content in harvested crops was
2 estimated by multiplying a crop yield (dry matter) and N concentration, while that of residues
3 was estimated using a crop yield (dry matter) and a dry-weight mass ratio (residue:yield), and
4 N concentration. The dry-weight mass ratios were determined by compiling crop statistics data
5 provided by the Resources Survey Laboratory (Resources Survey Laboratory, STA 1982).

6 We calculated the amounts of livestock N demand and N excreta based on the dietary
7 needs for their intake, and based on the rates indicated for each type of livestock in Table 3.
8 The information on the livestock population of Nakashibetsu town was obtained from the
9 Agricultural Census (Hokkaido Statistics and Information Office 2004, 2005). Data on N
10 demand was obtained from Nagumo (2000) for beef cattle, pigs, poultry, and horses. The N
11 demand for dairy cattle was estimated using the feeding data of dairy cattle from the Hokkaido
12 Statistics and Information Office (2004). Data on livestock excreta was obtained from Tsuiki
13 and Harada (1997). Milk N production from dairy cattle was calculated by multiplying the
14 amount of production (Hokkaido Statistics and Information Office 2004, 2005) and N
15 concentration of milk. Milk N concentration (0.512%) was calculated using a protein
16 concentration (Resources Council, STA 2000) and the mass ratio of N to milk protein (1:6.38).
17 Production of other livestock (kg N head^{-1}) was calculated based on the census data (Hokkaido
18 Statistics and Information Office 2004) for beef cattle, and was obtained from Nagumo (2000)
19 for pigs, poultry, and horses. Data on bedding litter for livestock was from Nagumo (2000)
20 and all the litter was assumed to be supplied by harvested crops. Self-supported feed was
21 estimated assuming that all yields of grass and maize were used for animals. The rest of the
22 livestock N demand was assumed to be supplied by the imported feed. The ΔS_{liv} , the
23 difference between input and output for livestock, was described as follows:

$$\Delta S_{liv} = N_{selfe} + N_{imfe} - N_{exc} - N_{pro_liv} \quad (5)$$

where N_{selfe} is self-supported feed, N_{imfe} is imported feed, N_{exc} is livestock excretion, and N_{pro_liv} is livestock production. Because the N demand ($N_{selfe} + N_{imfe}$), N_{exc} and N_{pro_liv} were estimated from different data sources, there existed ΔS_{liv} (Table 3). The ΔS_{liv} may show N stocks in animal bodies. We defined the NNI as not containing the ΔS_{liv} (Eq. (1)).

The export of food and feed (N_{exp}) was calculated as the total production of N minus the amount N consumed by humans or livestock as follows:

$$N_{exp} = N_{harv} + N_{pro_liv} - N_{selfe} - N_{selfo} - N_{litter} \quad (6)$$

where N_{harv} is harvested crops, N_{litter} is bedding litter for livestock.

Substituting Eqs. 2, 4-6 into Eq. (1) resulted in the following equation:

$$NNI = N_{chem} + N_{fix} + N_{dep} + N_{exc} + N_{sew} + N_{litter} - N_{harv} \quad (7)$$

17 Estimation of internal N budgets

We also estimated the surplus N in each type of land use such as upland (N_{surp_up}), urban (N_{surp_urban}), and forest (N_{surp_f}) from internal N flows. Disposed animal excreta (N_{disp}) was also estimated. The disposed animal excreta stand for the excreta that are not utilized for agricultural practices (Nagumo and Hatano 1999; Mishima 2001) and the fate of it is not clear.

Upland surplus N (N_{surp_up}) is the annual surface balance in the uplands, estimated as follows:

$$N_{surp_up} = N_{chem} + N_{fix} + N_{dep_up} + N_{dep_am} + N_{ma} + N_{resi} - N_{harv} - N_{am_chem} - N_{resi} \quad (8)$$

where N_{dep_up} is DIN deposition to the uplands and N_{dep_am} is a re-deposition of emitted NH_3 to the uplands, which was calculated as a sum of volatilized NH_3 from livestock excreta (N_{am_exc}) and chemical fertilizer (N_{am_chem}). The volatilized NH_3 from livestock excreta and chemical fertilizer was estimated by multiplying the excreta N by the NH_3 emission factor for each animal (Bouwman *et al.* 1997, Table 3) and was estimated to be 7% of the applied chemical N fertilizer (Bouwman and Bowmans 2002). The N_{ma} is the applied livestock manure on the farm estimated by multiplying the manure utilization ratio (Table 3) by livestock excreta (and bedding litter) after NH_3 volatilization. The manure utilization ratio was obtained from the Hokkaido Statistics and Information Office (2004) for dairy cattle, beef cattle, and pigs, and to Nagumo (2000) for poultry and horses. All crop residues were assumed to be left on site so that they were recycled in the uplands (Fig. 2). The N_{surp_urban} and N_{surp_f} were estimated as follows:

$$N_{surp_urban} = N_{dep_urban} + N_{sew} \quad (9)$$

$$N_{surp_f} = N_{dep_f} \quad (10)$$

where N_{dep_urban} and N_{dep_f} are DIN deposition to the urban and the forest areas, respectively.

The N_{disp} was calculated as follows:

$$N_{disp} = N_{exc} + N_{litter} - N_{ma} - N_{am_exc} \quad (11)$$

The N_{dep} was estimated as a sum of the DIN deposition in each type of land use as follows:

$$N_{dep} = N_{dep_up} + N_{dep_urban} + N_{dep_f} \quad (12)$$

Combining Eqs. 8-11 and 12 resulted in the following equation:

$$N_{surp_up} + N_{surp_urban} + N_{surp_f} + N_{disp} = N_{chem} + N_{fix} + N_{dep} + N_{exc} + N_{sew} + N_{litter} - N_{harv} \quad (13)$$

Combining the Eqs. 7 and 13, we obtained the following equation:

$$NNI = N_{surp_up} + N_{surp_urban} + N_{surp_f} + N_{disp} \quad (14)$$

Sewage treatment system

The amount of N removal through a sewage treatment plant was estimated. Data on population with regard to sewage waste at Nakashibetsu town were obtained from the website (<http://www.jma.go.jp/menu/report.html>) of Japan Sewage Works Association 2007. We used the data on the quality of the sewage effluent water and water volume (inlet and outlet) of the treatment plant in Nakashibetsu town (from 1994 to 2004, unpublished data), and calculated the mean N removal efficiency ($1 - \text{outlet N} / \text{inlet N}$) as 69%.

Estimation of the NNI for drainage basins

To convert the amount of upland N flows for Nakashibetsu town to that for the SRC, a factor of 1.42, which was calculated by dividing the upland area of the SRC by that of Nakashibetsu town, was multiplied by each amount of N flow estimated for Nakashibetsu

1 town. Human population in the SRC was assumed to be the same since most of the human
2 population in Nakashibetsu town is living in the catchment and few people are from the
3 neighboring towns.

4 For the other four drainage basins ('B', 'C', 'D', and 'E'), NNI (Eq. 12) was calculated
5 by dividing the amount of N_{surp_up} , N_{surp_urban} , N_{surp_f} , and N_{disp} by the area of each type of land
6 use proportionally for each drainage basin.

7 **Estimation of riverine N export**

8 *Water sampling*

9 River water samples were collected at five monitoring stations in the SRC from March
10 2003 to November 2004. Water sampling was conducted once in each season: spring (April),
11 summer (July), fall (September), and winter (November) at base flow events. Daily sampling
12 was conducted during the snowmelt season from mid March to mid May using an automated
13 water sampler (ISCO-6712, Teledyne Isco, Inc. Lincoln NE, USA), except for drainage basin
14 'E' where the sampler could not be set up due to deep snow cover. The automated water
15 sampler could not be set up at both 'B' and 'D' drainage basins during the snowmelt in 2003.

16 An intensive monitoring was also conducted during each rainfall in such a way that water
17 sampling was automatically done for two days in 24 bottles when the rainfall exceeded 4
18 mm/30 min. Water samples were collected in a 1 L polypropylene bottle separately from each
19 drainage basin for the chemical analysis. During the two-year monitoring, total water samples
20 were 484, 425, 298, 302, and 293 at drainage basins 'A', 'B', 'C', 'D', and 'E', respectively.

21 *River runoff*

22 For drainage basin 'A', hourly runoff data was obtained from the Water Information
23 System (Ministry of Land, Infrastructure and Transport, Japan 2007). For the remaining four

1 drainage basins ('B', 'C', 'D', and 'E'), runoff was estimated by H-Q equations (quadratic
2 curve), which are the relationships between runoff (Q) and water table (H) (Tachibana and
3 Nasu 2003). For each stream, 5 to 11 measurements of runoff were carried out during both
4 high and low flow conditions throughout the study period. The runoff was calculated by
5 multiplying the cross sectional area of the river by the river velocity measured with a velocity
6 meter (TK-105, Toho Dentan, Tokyo) at 60% depth at 8 to 10 points along a transect of the
7 river. The river velocity was measured only when the runoff measurements were conducted
8 (5-11 times). The H-Q equations were obtained from the measured runoff and water tables at
9 the time the runoff was measured (Appendix 1). In 'E' drainage basin, the R^2 value was low
10 possibly because the water table fluctuations were relatively small when the runoff
11 measurements were conducted. Water tables were measured every 15 minutes by a water table
12 sensor (MC-1100W, STS, Sirmach, Switzerland) installed at the river outlet where water
13 samples were collected. The water table data were collected with a data logger equipped with
14 a water table sensor. A continuous runoff was obtained by substituting the water table data for
15 H-Q equations. Hourly runoff was calculated by integrating four measurement data obtained
16 per hour.

17 During the winter period (December-February), runoff at four drainage basins was
18 estimated assuming the same discharge per unit of drainage area as drainage basin 'A' since
19 the water table sensor could not be set up during this period.

20 *Chemical analysis of water samples*

21 After sampling, water samples were stored on ice until transported to the laboratory and
22 were then stored at 4°C until the analysis. A portion of the water samples was filtered through
23 0.2- μ m membrane filters within a few days, and was analyzed for dissolved nutrients. The

1 remaining non-filtered samples were used for total N (TN) analysis. Concentrations of TN and
2 total dissolved N (TDN) were determined by the method of alkaline persulfate digestion and
3 HCl-acidified UV detection; NO_3^- -N and NO_2^- -N were determined by ion chromatography
4 (QIC Analyzer; Dionex, Sunnyvale, CA, USA); and NH_4^+ -N was determined by colorimetry
5 using the indophenol blue method. Particulate organic N (PON) and dissolved organic N
6 (DON) concentrations were calculated by subtracting the concentration of TDN from TN, and
7 inorganic N (NO_3^- -N, NH_4^+ -N, and NO_2^- -N) from TDN, respectively.

8 *Calculation of riverine N export*

9 The nutrient loads were estimated by an L-Q equation. The relationship between the
10 nutrient load (L) and runoff (Q) expressed by the L-Q equation has been adopted to estimate
11 nutrient loads from many rivers in Japan (Tachibana *et al.* 2001; Okazawa *et al.* 2005; Fujii *et*
12 *al.* 2006). By using the equation, nutrient loads can be estimated from the runoff rates that are
13 continuously measured. Intensive water monitoring during such a high flow event is required
14 to make L-Q equations for estimating nutrient loads accurately because the riverine N export
15 from the areas located in steep geographical conditions during the snowmelt period and storm
16 events accounted for about half of the annual export in Japan (Tachibana *et al.* 2001; Okazawa
17 *et al.* 2005). Although the L-Q equation has difficulty in estimating the nutrient loads when
18 they do not depend on the river runoff, the relationship between loads and runoffs were
19 relatively strong for TN and NO_3^- -N (Stevens and Smith 1978; Tabuchi and Hayashi 1987).

20 The riverine nutrient load Li , which is the amount of nutrients flowing downstream
21 through the river, was calculated from the data of concentration Ci and runoff Qi measured at
22 time i by the following equation:

23

$$Li = CiQi \quad (15)$$

2

3 The L-Q equation is described as follows:

4

$$Li = aQi^b \quad (16)$$

6

7 where a and b are coefficients obtained from the logarithmic linear regression of the

8 relationship between Li and Qi by the least-squares method. The Qi were calculated from the

9 water table data as described above (H-Q equation). Then, the cumulative load (Lc) in terms of

10 riverine export was calculated as follows:

11

$$Lc = \sum aQi^b \quad (17)$$

13

14 The L-Q equations were made for TN, TDN, and NO_3^- -N for each drainage basin and for

15 two seasons (snowmelt and the remaining period) in 2003 and 2004, separately (Appendix 2,

16 3).

17 For NH_4^+ -N and NO_2^- -N, the annual export of N was calculated by multiplying the

18 volume-weighted mean concentrations (VWM) and the annual runoff, since the N load due to

19 NH_4^+ -N and NO_2^- -N was not significantly correlated with the runoff. The VWM were

20 determined as:

21

$$VWM = (\sum Ci Qi) / \sum Qi \quad (18)$$

23

1 The PON export was calculated by the difference between TN and TDN exports. The
2 DON export was also calculated by the difference between TDN and DIN exports.

3 **Statistical analyses**

4 Statistical analyses were performed using Excel Toukei 97 for Windows (Social Survey
5 Research Information Co. Ltd. Japan). Statistically significant differences between means of
6 NO₃-N concentration for each drainage basin were determined by Steel Dwass test.
7 Correlation analysis was conducted to determine Pearson correlation coefficient (*r*) and the
8 value of probability (*P*) between variables. Simple linear regression was used to determine the
9 relationship between NNI and riverine N export of each N species. To compare the differences
10 in five crop yields between 2003 and 2004 (Table 2), a paired t-test was performed.

11 **Effect of a re-deposition rate of NH₃ on the estimation of NNI**

12 To evaluate the effect of a re-deposition rate of NH₃ on the estimation of NNI, the α value in
13 Eq. (2) was changed from 100% to 0.0%.

14 **RESULTS**

15 **NNI and internal N budgets for the Shibetsu river catchment**

16 The annual N flows for the SRC (drainage basin 'A') in 2003 and 2004 are given in Table
17 4. The values shown below represent the two-year average and the unit (kg N ha⁻¹ yr⁻¹)
18 represents the amount of N per unit area of the catchment (679 km²).

19 ***NNI***

20 Agriculture was found to be a dominant source of N in the SRC. The imported feed was
21 the largest source of N, accounting for 44% of the total N input (Table 4). Chemical fertilizer
22 and agricultural N fixation by crops were also the dominant source of N input (37 and 15% of
23 the total N input, respectively). The DIN deposition was 2% of the total N input. On the other

1 hand, export of food and feed was the largest output ($24.7 \text{ kg N ha}^{-1} \text{ yr}^{-1}$) from the SRC
2 representing 28% of the total N input. The ΔS_{liv} was $7.6 \text{ kg N ha}^{-1} \text{ yr}^{-1}$ (the ΔS_{hu} was assumed
3 to be zero). As a result, the NNI was estimated to be $54.6 \text{ kg N ha}^{-1} \text{ yr}^{-1}$ (63% of the total N
4 input) and was larger in 2003 ($58.5 \text{ kg N ha}^{-1} \text{ yr}^{-1}$) than in 2004 ($50.6 \text{ kg N ha}^{-1} \text{ yr}^{-1}$).

5 *Internal N budgets*

6 Upland surplus N was the largest N sink within the catchment ($49.1 \text{ kg N ha}^{-1} \text{ yr}^{-1}$)
7 accounting for 90% of the NNI (Table 4) and was larger in 2003 ($52.9 \text{ kg N ha}^{-1} \text{ yr}^{-1}$) than in
8 2004 ($45.3 \text{ kg N ha}^{-1} \text{ yr}^{-1}$) possibly due to higher crop yields in 2004 ($P < 0.05$, Table 2). The
9 surplus N in urban and forest areas and disposed animal excreta were 1.1, 0.9, and 3.4 kg N
10 $\text{ha}^{-1} \text{ yr}^{-1}$, respectively.

11 Animal excreta were the dominant internal flow in the catchment ($72.1 \text{ kg N ha}^{-1} \text{ yr}^{-1}$)
12 and were 2.2 times larger than the amount of chemical fertilizer. Volatized NH_3 from animal
13 excreta and chemical fertilizer was also a large internal flow which was estimated to be 18.0
14 and $2.3 \text{ kg N ha}^{-1} \text{ yr}^{-1}$, respectively.

15 Human excreta and sewage accounted for 2.0% of the total NNI ($1.1 \text{ kg N ha}^{-1} \text{ yr}^{-1}$) and
16 56% of it ($0.6 \text{ kg N ha}^{-1} \text{ yr}^{-1}$) was removed by the sewage treatment plant. Hence, 0.5 kg N
17 $\text{ha}^{-1} \text{ yr}^{-1}$ ($37.0 \text{ kg N ha}^{-1} \text{ yr}^{-1}$ per unit of urban area) was estimated to be discharged into the
18 river directly.

19 *NNI in five drainage basins*

20 The NNI in the five drainage basins ranged from 1.6 to $99.3 \text{ kg N ha}^{-1} \text{ yr}^{-1}$ over two years,
21 being largest in the upland dominated basin 'D' and smallest in the forest drainage basin 'E'
22 (Table 5).

1 Riverine export of N

2 *River runoff and climatic condition*

3 River runoff varied widely depending on rainfall events and seasons. Typically, high
4 water runoff was observed during the snowmelt flooding (mid March-June) and during heavy
5 rainfall events especially in 2003 (Fig. 3a). Higher precipitation and lower temperatures were
6 observed in 2003 than in 2004. The annual precipitation was 1276 and 883 mm in 2003 and
7 2004, respectively. The annual runoff at drainage basin 'A' was 1191 and 916 mm yr⁻¹ in 2003
8 and 2004, respectively, so that the runoff ratio was relatively high as 93% and 104%,
9 respectively. At the remaining four drainage basins such as 'B', 'C', 'D', and 'E', the runoff
10 ratios were 104, 104, 74, and 74% in 2003, and 121, 91, 71, and 91% in 2004, respectively.

11 *Riverine N concentration and N export*

12 In all drainage basins, high TN concentrations were observed during the rainfall events
13 mainly resulting from high PON concentration (Fig. 3a, b). The NO₃⁻-N concentrations tended
14 to increase during the early stage of snowmelt (mid March-April) and to decrease during its
15 later stage (May to June). The NH₄⁺-N concentrations remained low throughout the study
16 period (mean concentration to be < 0.03 mg N L⁻¹ in all drainage basins). The NO₂⁻-N
17 concentration was negligible at all drainage basins. The mean NO₃⁻-N concentrations differed
18 among drainage basins significantly ($P < 0.01$). The sequence of NO₃⁻-N concentrations
19 (median, 25% percentile, 75% percentile) was found as: 'D' (1.60, 1.42, 1.79 mg N L⁻¹) > 'C'
20 (1.07, 1.00, 1.16 mg N L⁻¹) > 'A' (0.54, 0.48, 0.64 mg N L⁻¹) > 'B' (0.30, 0.25, 0.40 mg N L⁻¹)
21 > 'E' (0.06, 0.10, 0.03 mg N L⁻¹). The median NO₃⁻-N concentration significantly correlated
22 with the proportion of the upland area (median NO₃⁻-N conc. = 0.0166 * proportion of upland
23 area + 0.0221, $R^2 = 0.901$, $P < 0.05$).

1 The riverine TN export ranged from 4.1 to 39.1 kg N ha⁻¹ yr⁻¹, NO₃⁻-N from 0.8 to 17.3
2 kg N ha⁻¹ yr⁻¹, DON from 0.8 to 6.2 kg N ha⁻¹ yr⁻¹, and NH₄⁺-N from 0.10 to 0.28 kg N ha⁻¹
3 yr⁻¹ (Table 5). The TN exports tended to be larger in 2003 compared to those in 2004 (Table
4 5).

5 **NNI and its relationship with riverine N export**

6 The amount of riverine N export increased with an increase in NNI (Fig. 4). The results
7 showed that both riverine TN ($r = 0.698$, $P < 0.05$) and NO₃⁻-N ($r = 0.909$, $P < 0.01$) exports
8 significantly correlated with the NNI. The slopes of the equations indicated that riverine TN
9 and NO₃⁻-N exports accounted for 27% and 14% of the NNI, respectively (Fig. 4). The TDN
10 and DON also correlated significantly with the NNI. The riverine export of NO₃⁻-N from
11 drainage basin 'A' tended to be less than that from 'C', although both drainage basins had a
12 similar amount of NNI. Compared to other N species, the fraction of NO₃⁻-N in TN increased
13 remarkably with an increase in the NNI (Fig. 5).

14 **Effect of a re-deposition rate of NH₃ on the estimation of NNI**

15 The change in a re-deposition rate of volatilized NH₃ (α ; $N_{\text{dep_am}}/N_{\text{am}}$) influenced the
16 estimation of NNI. Figure 6 shows that a 10% change in α value altered NNI and TN export /
17 NNI at a rate of 3.7% and 1.3%, respectively. Assuming that the α value changed from 100%
18 to 0%, NNI decreased by 37.4% (from 54.5 to 34.3 kg N ha⁻¹ yr⁻¹), resulting in an increase in
19 TN export / NNI to 35.0% (Fig. 6).

20 **DISCUSSION**

21 **Fate of NNI and uncertainties**

22 The increase in the riverine N export with an increase in NNI (Fig. 4) indicates that
23 altering the N cycle by anthropogenic activities in the SRC will increase N export to rivers.

1 The riverine export of TN was 27% and 17% of NNI in 2003 and 2004, respectively in the
2 SRC (drainage basin 'A') (Fig. 4, Table 5). These values were similar to the findings reported
3 by Howarth *et al.* (1996) and Boyer *et al.* (2002) in comparatively larger watersheds. The fate
4 of the remaining NNI that was not explained by the riverine export is considered to be either
5 lost to the atmosphere by denitrification, or stocked in soils and woody biomass (Howarth *et*
6 *al.* 1996; Van Breemen *et al.* 2002).

7 Denitrification losses in the soil profile could be an important flux of N in the SRC. An
8 estimate of denitrification in upland soils by Yatazawa (1978) of 30 kg N ha⁻¹ yr⁻¹ would
9 account for 26% of NNI in the SRC. However, the denitrification potential of surface soils
10 measured in the SRC varied for different types of land use, being highest in lowland wetlands
11 compared to that in riparian forests and grasslands (Hayakawa *et al.* 2006). Van Beek *et al.*
12 (2004) reported a high denitrification rate (87 kg N ha⁻¹ yr⁻¹) in a peat soil under grasslands,
13 since there was an ample source of energy for denitrifying bacteria in the form of carbon
14 available throughout the soil profile. Because most of the wetlands located at the lower part of
15 the Shibetsu River have disappeared, denitrification might have been more substantial in the
16 grasslands on the lowland peat soil. Although there is uncertainty in the estimation of river
17 runoff, lower values of NO₃-N concentration and export observed in drainage basin 'A' than in
18 'C' with almost the same NNI (Fig. 3a, b, Fig. 4) suggested that denitrification could have
19 occurred in the lower part of the SRC.

20 Riverine denitrification could be less, because of the negligible proportion of water
21 bodies out of the total surface area (Seitzinger *et al.* 2006) and relatively low water
22 temperature and high water discharge (Hill 1979; Royer *et al.* 2004) throughout the year in the
23 Shibetsu River.

1 The fate of NH_3 volatilized within the SRC influenced the estimation of NNI (Fig. 6)
2 because NH_3 volatilization was large in the SRC (Table 4). If all the NH_3 had been exported
3 outside the SRC, NNI would have decreased by 37% (Fig. 6). However, a comparatively low
4 amount of DIN deposition in the SRC suggests that the transport-distance of N from farms or
5 grassland through the air was not long. Even if all DIN deposition measured in the SRC was
6 from NH_3 volatilized within the SRC, it would only account for 9.4% of the volatilized NH_3 .
7 A large part of NH_3 originating from a manure barn was deposited within 1 km as dry and wet
8 deposition during its transportation (Hojito *et al.* 2006; Pitcairn *et al.* 1998). The mean value
9 of NH_3 concentration in the air at 490 m away from a manure barn was $2.4 \mu\text{g N m}^{-3}$ measured
10 in the SRC (Hojito *et al.* 2006). This value was remarkably low compared to the reported
11 values near the livestock sheds or manure barn such as $20\text{-}60 \mu\text{g N m}^{-3}$ (Pitcairn *et al.* 1998)
12 and $36.2 \mu\text{g N m}^{-3}$ (Hojito *et al.* 2006). These studies supported the assumption that the NH_3
13 re-deposition rate used in this study was likely to be an appropriate range since monitoring
14 stations in this study were not close to farms and grasslands. In a previous study, NH_3
15 re-deposition rates were assumed to be 75% (Boyer *et al.*, 2002) and 100% (Howarth *et al.*,
16 1996) of NH_3 volatilization. In the SRC, a large amount of NH_3 may be trapped in the
17 grassland edges of forests (Fig. 1), which might function as traps and concentrators for
18 wind-borne nutrients and pollutants (Weathers *et al.* 2001). Although one part of NH_3 can
19 become a particulate and can be transported from a drainage basin (Asman 2001), most NH_3
20 originates from farms may be merely recycled as agricultural N around the farms. Further
21 research is required to evaluate the fate of volatilized NH_3 as well as to monitor NH_3
22 volatilizations, especially in livestock farming regions like the SRC.

23 A part of the NNI could have been stocked in soil temporarily before being exported to

1 rivers. In the SRC, N input to the uplands was dominated by animal manure N (Table 4). A
2 considerable transit time is required for manure-derived nitrate to be transported into
3 groundwater (Maeda *et al.* 2003) and rivers so that a portion of manure N will accumulate in
4 soil in an organic form for a few years (Muñoz *et al.* 2003). These may cause significant
5 delays in riverine N export from the drainage basins. In contrast, an increased export of DON
6 with the NNI (Fig. 4) suggested that manure-derived N could also have been exported to rivers
7 as an organic form. The DON concentrations in rivers measured at base flow events in the
8 SRC also significantly correlated with the proportion of upland area (Hayakawa *et al.* 2006).
9 Miura and Ae (2005) reported that leaching of DON was observed in a field receiving high
10 amount of poultry manure.

11 The ΔS_{liv} includes uncertainties and could result in estimation errors of the NNI. The
12 ΔS_{liv} was estimated as $7.6 \text{ kg N ha}^{-1} \text{ yr}^{-1}$ (drainage basin 'A' in 2003) accounting for 8% of the
13 total N input. We defined the ΔS_{liv} as an increment of animal bodies and were not included in
14 the NNI estimation. However, ΔS_{liv} likely involved leftover feed by an excess of feeding. In
15 this case, ΔS_{liv} should be included in disposal N since the leftover feed could have been
16 disposed along with the manure. Hence, the NNI values could have been underestimated.

17 The river runoff was sometimes greater than precipitation, resulting in a high runoff ratio
18 in the SRC. This could have caused an overestimation of the riverine N export. The reason for
19 a high runoff ratio in the SRC is not understood. Runoff ratios in Japanese river in snowy
20 regions are often over 80% (Arai 2004) so that one possible reason could be an
21 underestimation of snowfall on mountains in upper drainage basins. Another possible reason
22 could be inflow of underflow water from Lake-Mashu located at the north-western part of the
23 SRC. There are no rivers originating from the lake so that an underflow-water could be a

1 possible way of export from the lake (National Institute for Environmental Studies *et al.* 2004).
2
3
4 1 possible way of export from the lake (National Institute for Environmental Studies *et al.* 2004).
5
6 2 Lake-Masyu is an oligotrophic lake with a TN concentration as low as below 0.1 mg N L^{-1}
7
8
9 3 (National Institute for Environmental Studies *et al.* 2004). It seemed that the river runoff
10
11 4 increased and the N concentration in the river water was diluted by the underflow water.
12
13
14 5 Annual potential evapotranspiration (PET) was estimated by Thornthwaite equation
15
16
17 6 (Thornthwaite 1948) using monthly mean temperature in the SRC, and amount of
18
19 7 underflow-water was assumed to be the difference between ‘annual runoff’ and ‘annual
20
21 8 precipitation – PET’. As a result, the N inflow from underflow water to the SRC, which was
22
23 9 estimated by multiplying TN concentration in Lake-Masyu by the amount of underflow water,
24
25 10 accounted for 2.1 and 5.5% of TN export in the drainage basin ‘A’ in 2003 and 2004,
26
27 11 respectively. Therefore, the riverine N export might not have been overestimated excessively.
28
29 12 Assessing the underflow water from outside the drainage basin would be crucial in order to
30
31 13 measure the river runoff precisely.
32
33
34
35
36

37 14 The climatic condition could have influence on the fate of the NNI. The higher
38
39 15 precipitation in 2003 caused higher runoff resulting in a larger N export from rivers compared
40
41 16 to that in 2004 (Table 5). David *et al.* (1997) reported that riverine NO_3^- -N export was much
42
43 17 higher in years with greater precipitation during a six-year period. In contrast, riverine N
44
45 18 export in the Oldman River Basin, located in southern Canada with a semi-arid climate,
46
47 19 accounted for only 1% of the N inputs (Rock and Mayer 2006). Howarth *et al.* (2006) reported
48
49 20 that those watersheds having higher precipitation and higher discharge could export N from
50
51 21 rivers as a greater fraction of the NNI. Air temperature can also influence on estimation of the
52
53 22 NNI. A large amount of crop yield was observed in 2004 (Table 2) possibly due to warmer
54
55 23 temperatures in 2004, which could have led to a decrease in upland surplus N in 2004 than in
56
57
58
59
60

1 2003. The air temperature possibly limits crop production in a hemi-boreal climatic region like
2 the SRC. Hence, lower temperatures and higher precipitation observed in 2003 might have
3 resulted in both a larger NNI and riverine N export compared to those in 2004.

4 **Nitrogen cycle in the Shibetsu River catchment**

5 The SRC was a net importer of feed (Table 4) because grass production met only 63% of
6 the total N demand of animals, resulting in production of a large amount of animal N excreta
7 per unit of upland ($140 \text{ kg N ha}^{-1} \text{ yr}^{-1}$). Since grass production was $134 \text{ kg N ha}^{-1} \text{ yr}^{-1}$ per unit
8 of upland, the animal excreta N not taken up by grass would inevitably be generated. As a
9 result, upland surplus N was the large N sink in the SRC (Table 4). This appeared to be a
10 typical characteristic of the N cycle at dairy farming regions in Japan.

11 Chemical N fertilizer was also a dominant source of N in the SRC (Table 4). It was
12 recognized that the increased use of fertilizer was one of the main contributors of increased
13 annual nitrate flux to the Gulf of Mexico (Goolsby and Battaglin 2001). A field experiment
14 conducted in the SRC for a two-year experiment showed that grass production and soil
15 fertility (available N content) were maintained in grasslands of Andisol soils, of which the
16 available phosphorus content was over $200 \text{ mg P}_2\text{O}_5 \text{ kg}^{-1}$, even if the application of chemical
17 N fertilizer was reduced from 80 to $40 \text{ kg N ha}^{-1} \text{ yr}^{-1}$ (Sakai *et al.* 2004). Assuming that the
18 chemical fertilizer in the grasslands decreased from 63 (used in this model) to $40 \text{ kg N ha}^{-1} \text{ yr}^{-1}$
19 and the grass yield was maintained, the NNI would decrease by 23% in the SRC. A reduction
20 in surplus N was achieved by reducing chemical N fertilizer and imported feed by an
21 appropriate management at the prototype farm 'De Marke' without decreasing milk
22 production and crop yield (Aarts *et al.* 2000). Since nutrient-management performance varied
23 largely among farmers (Ondersteijn *et al.* 2002), an effort that uses N (especially animal

1
2
3
4 1 excreta, chemical N fertilizer, and imported feed) effectively will lead the reduction of the
5
6
7 2 NNI and N pollution in the environment.

8
9 3 Controlling point sources can also reduce N pollution in the environment. In our study,
10
11 4 human excreta and sewage were only 2% of the total NNI; however, it was up to 76 kg N ha⁻¹
12
13 yr⁻¹ per unit of urban area. Even considering the removal of N at the sewage treatment plant,
14
15 5 the remaining N (37 kg N ha⁻¹ yr⁻¹ per unit of urban area) could have entered the river directly
16
17 6 as a point source of water pollution. Waste water from factories can be also point sources of
18
19 7 water pollution. The leakage of nutrients from livestock housing, silage silo, milking parlor,
20
21 8 and slurry/manure storage at a dairy farm is recognized as a point source of water pollution
22
23 9 (Hooda *et al.* 2000). Woli *et al.* (2002) reported that TN concentration in a small stream
24
25 10 dramatically increased after mixing of discharge from an intensive livestock farm, which had a
26
27 11 constructed wetland with 63 mg TN L⁻¹ concentration of drainage water. A close monitoring of
28
29 12 such point sources is required to evaluate the impact of point sources on riverine N export and
30
31 13 to propose a mitigation of water pollution.
32
33
34
35
36
37
38
39

40 **Conclusions**

41
42 16 By using a simple N budgeting model, this study presents a general scenario of the
43
44 17 existing N cycle in the Shibetsu River catchment (SRC), which is one of the largest dairy
45
46 18 farming catchments in Japan. Although this type of N mass balance approach was subject to
47
48 19 many assumptions and limitations in the available data, the results indicated possible areas for
49
50 20 further study and measurements to reduce errors in estimating important fluxes and also
51
52 21 contributed to provide an insight into possible mitigation strategies to prevent a future
53
54 22 degradation of water quality due to N inputs from anthropogenic sources in the SRC.
55
56
57
58
59
60

23 Agricultural N was the dominant source of N for the SRC. The imported feed (44% of

1 the total N input to the SRC), chemical fertilizer (37%) and N fixation by crops (15%) were
2 the large N sources, resulting in excessive animal excreta and surplus N in the farmland. As a
3 result, the NNI was estimated to be 54.6 kg N ha⁻¹ yr⁻¹ in the SRC. Human sewage accounted
4 for 2% of the NNI and was removed at a sewage treatment plant by 56%. The riverine TN
5 export correlated with the NNI and accounted for 27% of the NNI. Hence, the focus should be
6 on controlling agricultural N to mitigate the degradation of water quality in the SRC. The fate
7 of the residual NNI that was not explained by riverine export was possibly denitrified and/or
8 retained within the SRC. In contrast, changing the assumptions of the deposition-rate of NH₃
9 from 100 to 0% redeposited within the SRC would have reduced the NNI by 37%. Further
10 research is required to evaluate denitrification, N stocks in soil, and the fate of NH₃ volatilized
11 in the SRC.

12 ACKNOWLEDGMENTS

13 We thank Dr. Toshiya Saigusa, Mr. Osamu Sakai, Mr. Hiroyuki Koda, and Mr.
14 Toshinobu Koba, Hokkaido Agricultural Experiment Station of Konsen Branch, for their help
15 and suggestions on this study. This study was partly supported by a Japanese Grant-in-Aid for
16 Science Research from the Ministry of Education, Culture, Sports, Science and Technology
17 (No.14209002 and No, 19201008) and the research grants was provided by the 'Hokkaido
18 Regional Development Bureau for the Restoration Project in the Shibetsu River'.
19

20 REFERENCES

- 21 Aarts HFM, Habekotté B, van Keulen H 2000: Nitrogen (N) management in the 'De Marke'
22 dairy farming system. *Nutr. Cycl. Agroecosys.*, **56**, 231-240.
23 Agriculture, Forestry and Fisheries Research Council Secretariat, Ministry of Agriculture,

- 1
2
3
4 1 Forestry and Fisheries 1995: Standard Table of Feed Composition in Japan. pp 13-103,
5
6 2 185-205. Tokyo (In Japanese).
7
8
9 3 Arai T 2004: The foundation of water balance observation and analysis. Heat and water
10
11 4 balance hydrology for regional analysis, pp 43-69. Kokonsyoin, Tokyo (In Japanese).
12
13
14 5 Asman WAH 2001: Modelling the atmospheric transport and deposition of NH₃ and
15
16 6 ammonium: an overview with special reference to Denmark. *Atmos. Environ.*, **35**,
17
18 7 1969-1983.
19
20
21
22 8 Borbor-Cordova MJ, Boyer EW, Mcdowell WH, Hall CA 2006: Nitrogen and phosphorus
23
24 9 budgets for a tropical watershed impacted by agricultural land use: Guayas, Ecuador.
25
26
27 10 *Biogeochemistry*, **79**, 135-161.
28
29
30 11 Bouwman AF, Boumans LJM 2002: Estimation of global NH₃ volatilization loss from
31
32 12 synthetic fertilizers and animal manure applied to arable lands and grasslands. *Global*
33
34 13 *Biogeochem. Cycles*, **16**, 8-1-8-15.
35
36
37 14 Bouwman AF, Lee DS, Asman WAH, Dentener FJ, Van der Hoek KW, Olivier JGJ 1997: A
38
39 15 global high-resolution emission inventory for NH₃. *Global Biogeochem. Cycles*, **11**,
40
41 16 561-587.
42
43
44
45 17 Boyer EW, Goodale C, Jaworski NA, Howarth RW 2002: Anthropogenic nitrogen sources and
46
47 18 relationships to riverine nitrogen export in the northeastern U.S.A. *Biogeochemistry*, **57/58**,
48
49 19 137-169.
50
51
52
53 20 Boyer EW, Howarth RW, Galloway JN, Dentener FJ, Green PA, Vörösmarty CJ 2006:
54
55 21 Riverine nitrogen export from the continents to the coasts. *Global Biogeochem. Cycles*, **20**,
56
57 22 GB1S91.
58
59
60 23 Carpenter S, Caraco FN, Correll DL, Howarth RW, Sharple AN, Smith VH 1998: Non-point

- 1 pollution of surface waters with phosphorus and nitrogen. *Ecology*, **3**, 1-12.
- 2 David MB, Gentry LE 2000: Anthropogenic input of nitrogen and phosphorus and riverine
3 export for Illinois, USA. *J. Environ. Qual.*, **29**, 494-508.
- 4 David MB, Gentry LE, Kovacic DA, Smith KM. 1997: Nitrogen balance in and export from
5 an agricultural watershed. *J. Environ. Qual.*, **26**, 1038-1048.
- 6 Fujii S, Shivakoti BR, Shichi K, Songprasert P, Ihara H, Moriya M, Kitpati S, Tanaka S 2006:
7 Analysis of parameter variations in L-Q equations for river runoff processes from the
8 viewpoint of spatial and temporal conditions. *Water Sci. Technol.*, **53**, 141-152.
- 9 Galloway JN, Cowling EB 2002: Reactive nitrogen and the world: 200 years of change.
10 *Ambio*, **31**, 64-71.
- 11 General Food Policy Bureau, Ministry of Agriculture, Forestry and Fisheries 2004: Food
12 balance sheet. Tokyo (In Japanese).
- 13 Goolsby DA, Battaglin WA 2001: Long-term changes in concentrations and flux of nitrogen in
14 the Mississippi River basin, USA. *Hydrol. Processes*, **15**, 1209-1226.
- 15 Hayakawa A, Shimizu M, Woli KP, Kuramochi K, Hatano R 2006: Evaluating stream water
16 quality through land use analysis in two grassland catchments: Impact of wetland on stream
17 nitrogen concentration. *J. Environ. Qual.*, **35**, 617-627.
- 18 Hill AR 1979: Denitrification in the nitrogen budget of a river ecosystem. *Nature*, **281**,
19 291-292.
- 20 Hojito M, Ikeguchi A, Kohyama K, Shimada K, Ogino A, Mishima S, Kaku K 2003:
21 Estimation of nitrogen loading in Japanese prefectures and scenario testing of abatement
22 strategies. *Jpn. J. Soil Sci. Plant Nutr.*, **74**, 467-474 (In Japanese).
- 23 Hojito M, Matsunami H, Hayashi K, Murano K, Mori A 2006: The status of wet deposition of

- 1
2
3
4 1 nitrogen compounds in an intensive dairy farming area in central Japan. *Jpn. J. Soil Sci.*
5
6
7 2 *Plant Nutr.*, **77**, 47-52 (In Japanese).
8
9 3 Hokkaido Agricultural Experiment Station, Tenpoku and Konsen Branches 2000: Current
10
11 4 status and problem of grass production in Hokkaido. pp 121-137. Sapporo (In Japanese).
12
13
14 5 Hokkaido Department for Agropolicy 2002: Hokkaido Fertilizer Application Guide. pp
15
16 6 14-229. Sapporo (In Japanese).
17
18
19 7 Hokkaido Statistics and Information Office, Ministry of Agriculture, Forestry and Fisheries of
20
21 8 Japan 2004, 2005: The Statistical Yearbook of Agriculture, Forestry and Fisheries in
22
23 9 Hokkaido (Agricultural Statistics in Hokkaido by Municipalities). Sapporo (In Japanese).
24
25
26
27 10 Hokkaido Statistics and Information Office, Ministry of Agriculture, Forestry and Fisheries of
28
29 11 Japan 2004: The Statistical Yearbook of Agriculture, Forestry and Fisheries in Hokkaido
30
31 12 (Agricultural management). Sapporo (In Japanese).
32
33
34
35 13 Hooda PS, Edwards AC, Anderson HA, Miller A 2000: A review of water quality concerns in
36
37 14 livestock farming area. *Sci. Tot. Environ.*, **250**, 143-167.
38
39
40 15 Howarth RW, Billen G, Swaney D, Townsend A, Jaworski N, Lajtha K, Downing JA, Elmgren
41
42 16 R, Caraco N, Jordan T, Berendse F, Freney J, Kudeyarov V, Murdoch P, Zaho-Liang Z
43
44 17 1996: Regional nitrogen budgets and riverine N and P fluxes for the drainages to the North
45
46 18 Atlantic Ocean: Natural and human influences. *Biogeochemistry*, **35**, 75-139.
47
48
49
50 19 Howarth RW, Swaney DP, Boyer EW, Marino R, Jaworski N, Goodale C 2006: The influence
51
52 20 of climate on average nitrogen export from large watersheds in the Northeastern United
53
54 21 States. *Biogeochemistry*, **79**, 163-186.
55
56
57
58 22 Japan Meteorological Agency 2007: Information of meteorological statistics.
59
60 23 <http://www.jma.go.jp/menu/report.html> (December, 2007) (In Japanese).

- 1
2
3
4 1 Japan Sewage Works Association 2007: Current status of the diffusion ratio of sewage plant in
5
6 2 Japan. http://www.jswa.jp/05_arekore/07_fukyu/index.html (December, 2007) (In
7
8 3 Japanese).
- 9
10 4 Kunimatsu, T., and H. Muraoka 1997: Model analysis of river pollution. pp 13. Gihodoh,
11
12 5 Tokyo (In Japanese).
- 13
14 6 Maeda M, Zhao B, Ozaki Y, Yoneyama T 2003: Nitrate leaching in an Andisol treated with
15
16 7 different types of fertilizers. *Environ. Pollut.*, **121**, 477-487.
- 17
18 8 McIsaac GF, Hu X 2004: Net N input and riverine N export from Illinois agricultural
19
20 9 watersheds with and without extensive tile drainage. *Biogeochemistry*, **70**, 251-271.
- 21
22 10 Ministry of Land, Infrastructure and Transport, Japan 2007: Real time information of River
23
24 11 database. <http://www.river.go.jp/> (December, 2007) (In Japanese).
- 25
26 12 Mishima S 2001: Recent trend of nitrogen flow associated with agricultural production in
27
28 13 Japan. *Soil Sci. Plant Nutr.*, **47**, 157-166.
- 29
30 14 Mishima S, Matsumori M, Inoue T 2004: Construction of the database for estimation of
31
32 15 nitrogen flow and nitrogen balance in the districts in Japan. *Jpn. J. Soil Sci. Plant Nutr.*, **75**,
33
34 16 275-282 (In Japanese).
- 35
36 17 Miura N, Ae N 2005: Possibility of leaching of organic nitrogen in a field under heavy
37
38 18 application of organic matter -Model experiment using soil columns-. *Jpn. J. Soil Sci. Plant*
39
40 19 *Nutr.*, **76**, 843-848 (In Japanese).
- 41
42 20 Muñoz GR, Powell JM, Kelling KA 2003: Nitrogen budget and soil N dynamics after multiple
43
44 21 applications of unlabeled or ¹⁵Nitrogen-enriched dairy manure. *Soil Sci. Soc. Am. J.*, **67**,
45
46 22 817-825.
- 47
48
49
50
51
52
53
54
55
56
57
58
59
60 23 Nagumo T 2000: Research on evaluating the nitrogen cycling and environmental loads

- 1
2
3
4 1 associated with production and supply of food in regional level. Ph.D. diss. Hokkaido Univ.,
5
6
7 2 Sapporo(In Japanese).
8
9 3 Nagumo T, Hatano R 1999: Impact of nitrogen cycling associated with production and
10
11 4 consumption of food on nitrogen pollution of stream water. *Soil. Sci. Plant Nutr.*, **46**,
12
13 5 325-342.
14
15
16 6 Nakamura F 2003: Restoration strategies for rivers, floodplains and wetlands in Kushiro Mire
17
18 7 and Shibetsu River, northern Japan. *Ecol. Civil. Eng.*, **5**, 217-232 (In Japanese).
19
20
21 8 Nakasone H, Kuroda H, Mogi S 1997: Issues and its improvement of L-Q equation for
22
23 9 catchment area with seasonal paddy field irrigation. *Trans of JSIDRE.*, **190**, 71-76 (In
24
25 10 Japanese).
26
27
28 11 Nishio M 2002: Soil microbiology and the distorted material flows. 1. Agro-environmental
29
30 12 and soil microbial problems caused by the distorted material flows in Japan. *Jpn. J. Soil Sci.*
31
32 13 *Plant Nutr.*, **73**, 185-191 (In Japanese).
33
34
35 14 Okazawa H, Nagasawa T, Inoue T, Yamamoto T 2005: River hydrological conditions and
36
37 15 pollution load discharge for a livestock farming watershed in a South-western Hokkaido,
38
39 16 Japan. *Trans of JSIDRE.*, **240**, 603-610 (In Japanese).
40
41
42
43 17 Ondersteijn CJM, Beldman ACG, Daatselaar CHG, Giesen GWJ, Huirne RBM 2002: The
44
45 18 Dutch Mineral Accounting System and the European Nitrate Directive: implications for N
46
47 19 and P management and farm performance. *Agric. Ecosyst. Environ.*, **92**, 283-296.
48
49
50
51 20 Pitcairn CER, Leith ID, Sheppard LJ, Sutton MA, Fowler D, Munro RC, Tang S, Wilson D
52
53 21 1998: The relationship between nitrogen deposition, species composition and foliar nitrogen
54
55 22 concentrations in woodland flora in the vicinity of livestock farms. *Environ. Pollut.*,
56
57 23 **102**(supplement 1), 41-48.
58
59
60

- 1
2
3
4 1 Resources Council, Science and Technology Agency 1982: Standard tables of food
5
6 2 composition in Japan, 4th ed. vol. 87, pp 37-291. Report of resources survey committee,
7
8
9 3 Science and Technology Agency, Tokyo (In Japanese).
10
11 4 Resources Council, Science and Technology Agency 2000: Standard tables of food
12
13 5 composition in Japan, 5th ed. pp 254. Report of resources survey committee, Science and
14
15 6 Technology Agency, Tokyo (In Japanese).
16
17 7 Resources Survey Laboratory, Science and Technology Agency 1982: Basic survey of
18
19 8 utilization of biomass for energy resources. vol. 96 pp 63-74. Report of Resources Survey
20
21 9 Laboratory, Science and Technology Agency, Tokyo (In Japanese).
22
23 10 Rock L, Mayer B 2006: Nitrogen budget for the Oldman River Basin, southern Alberta,
24
25 11 Canada. *Nutr. Cycl. Agroecosyst.*, **75**, 147-162.
26
27 12 Royer TV, Tank JL, David MB 2004: Transport and fate of nitrate in headwater agricultural
28
29 13 streams in Illinois. *J. Environ. Qual.*, **33**, 1296-1304.
30
31 14 Sakai O, Hojito M, Miki N, Saigusa T 2004: Quality of fertilizer application for Timothy
32
33 15 (*Phleum pratense* L.)-White Clover (*Trifolium repens* L.) mixed grazing pasture. *Jpn. J.*
34
35 16 *Soil Sci. Plant Nutr.*, **75**, 711-714 (In Japanese).
36
37 17 Seitzinger S, Harrison JA, Böhlke JK, Bouwman AF, Lowrance R, Peterson B, Tobias C, Van
38
39 18 Drecht G 2006: Denitrification across landscapes and waterscapes: A synthesis. *Ecol. Appl.*,
40
41 19 **16**, 2064-2090.
42
43 20 Statistics Department, Ministry of Agriculture, Forestry and Fisheries 2003: Pocketbook of
44
45 21 livestock statistics. pp 26. Tokyo (In Japanese).
46
47
48
49
50
51
52
53
54
55
56
57
58
59
60

- 1
2
3
4 1 Stevens RJ, Smith RV 1978: A comparison of discrete and intensive sampling for measuring
5
6 2 the loads of nitrogen and phosphorus in the river Main, County Antrim. *Water Research*, **12**,
7
8 3 823-830.
9
10
11 4 Tabuchi T, Hayashi H 1987: Reliability of regression equations for the load and discharge of
12
13 5 rivers. *Trans of JSIDRE.*, 131,11-18 (In Japanese).
14
15
16 6 Tachibana H, Inoue T, Shinsho H 1997: The peat stratigraphy and vegetation of Shibetsu Mire,
17
18 7 Eastern Hokkaido. In: T. Tsujii, H. Tachibana, H. Shinsho, S. Uemura, K. Yabe (ed)
19
20 8 *Vegetation and Recent Changes of Mire Areas in Hokkaido — For the Conservation of*
21
22 9 *Mires in Hokkaido*. pp 151-170. Report of the Proc. Natural Foundation (Japan), Fiscal
23
24 10 Years of 1994/1995, Sapporo (In Japanese).
25
26
27 11 Tachibana H, Nasu Y 2003: Measurement of runoff. In: The Japan Society for Analytical
28
29 12 Chemistry, Hokkaido Branch (ed.) *Water Analysis*, pp 362-370. Kagaku Dojin, Kyoto (In
30
31 13 Japanese).
32
33
34 14 Tachibana H, Yamamoto K, Yoshizawa K, Magara Y 2001: Non-point pollution of Ishikari
35
36 15 river, Hokkaido, Japan. *Water Sci. Technol.*, **44**, 1-8.
37
38
39 16 Taube F, Wachendorf M, Kornher A 1996: Leistungsfähigkeit weiskleebasierter
40
41 17 Produktionssysteme auf dem Dauergrünland Norddeutschlands. *Zeitschrift Das*
42
43 18 *Wirtschaftseigene Futter Band*, **41**, 28-42.
44
45
46 19 Thornthwaite C W 1948: An approach toward a rational classification of climate.
47
48 20 *Geographical Review*, **38**, 55-94.
49
50
51 21 Tsuiki M, Harada Y 1997: Livestock excreta production in Japan and future themes. In: M.
52
53 22 Nishio (ed.) *Environment conservation and new livestock production*. pp 15-29.
54
55
56 23 Norinsuisangijutsukyokai, Tokyo (In Japanese).
57
58
59
60

- 1
2
3
4 1 Van Beek CL, Hummelink EWJ, Velthof GL 2004: Denitrification rates in relation to
5
6 2 groundwater level in a peat soil under grassland. *Biol. Fertil. Soils*, **39**, 329-336.
7
8
9 3 Van Breemen N, Boyer EW, Goodale CL, Jaworski NA, Paustian K, Seitzinger SP, Lajtha K,
10
11 4 Mayer B, Van Dam D, Howarth RW, Nadelhoffer KJ, Eve M, Billen G 2002: Where did all
12
13 5 the nitrogen go? Fate of nitrogen inputs to large watersheds in the northeastern U.S.A..
14
15 6 *Biogeochemistry*, **57/58**, 267-293.
16
17
18 7 Vitousek PM, Aber JD, Howarth RW, Likens G.E, Matson PA, Schindler DW, Schlesinger WH,
19
20 8 Tilman DG 1997: Human alteration of the global nitrogen cycle: sources and consequences.
21
22 9 *Ecol. Appl.*, **7**, 737-750.
23
24
25 10 Weathers KC, Cadenasso ML, Pickett STA 2001: Forest edges as nutrient and pollutant
26
27 11 concentrators: Potential synergisms between fragmentation, forest canopies, and the
28
29 12 atmosphere. *Conservation Biology*, **15**, 1506-1514.
30
31
32 13 Woli KP, Nagumo T, Hatano R 2002: Magnitude of nitrogen pollution in stream water due to
33
34 14 intensive livestock farming practices. *Soil Sci. Plant Nutr.*, **48**, 883-887.
35
36
37 15 Woli KP, Nagumo T, Kuramochi K, Hatano R 2004: Evaluating river water quality through
38
39 16 land use analysis and N budget approaches in livestock farming areas. *Sci. Tot. Environ.*,
40
41 17 **329**, 61-74.
42
43
44 18 Yatazawa M 1978: Agro-ecosystem in Japan. In: Frissel MJ (ed.) *Cycling of Mineral Nutrients*
45
46 19 *in Agricultural Ecosystems*. pp 167-179. Elsevier Scientific Pub. Co., Amsterdam.
47
48
49 20 Yoshida T 1981: Significance of symbiotic nitrogen fixation. In: Dojyou Biseibutsu
50
51 21 Kenkyu-kai (ed.) *Tsuchi no Biseibutsu*. pp 305-310. Hakuyu-sya, Tokyo (In Japanese).
52
53
54
55
56
57
58
59
60

1
2
3
4 1 Figure legends

5
6
7 2

8
9 3 Figure 1 Land use types and five drainage basins in the Shibetsu River catchment, Hokkaido,
10
11 4 Japan. The circles inside the catchment represent monitoring stations. Sampling of river water
12
13 5 and atmospheric DIN deposition and monitoring of water level were conducted at each
14
15 6 monitoring station. There is a large shelterbelt of lattice forest surrounding the grassland.
16
17 7

18
19
20
21
22 8 Figure 2 Nitrogen (N) fluxes from, to, and within the Shibetsu River catchment: The solid
23
24 9 arrows represent N flows we calculated and the dotted arrows represent N flows we did not
25
26
27 10 consider in this study. N_{fix} : agricultural N fixation by leguminous and non-leguminous crops,
28
29
30 11 N_{chem} : chemical fertilizer, N_{dep} : atmospheric DIN ($\text{NH}_4\text{-N} + \text{NO}_3\text{-N}$) deposition to whole
31
32 12 watershed, N_{imfe} : imported feed, N_{imfo} : imported food, N_{exp} : exported food and feed, $N_{\text{exp_am}}$:
33
34 13 exported NH_3 , $N_{\text{dep_f}}$: atmospheric DIN deposition to forest, $N_{\text{dep_up}}$: atmospheric DIN
35
36 14 deposition to upland, $N_{\text{dep_urban}}$: atmospheric DIN deposition to urban, N_{am} : NH_3 volatilization,
37
38 15 $N_{\text{am_chem}}$: NH_3 volatilization from chemical fertilizer, $N_{\text{am_exc}}$: NH_3 volatilization from
39
40 16 livestock excreta, $N_{\text{dep_am}}$: re-deposition of volatilized- NH_3 to upland, N_{exc} : livestock excreta,
41
42 17 N_{litter} : bedding litter, $N_{\text{pro_liv}}$: livestock production, $N_{\text{self_fo}}$: self-supported food, $N_{\text{self_fe}}$:
43
44 18 self-supported feed, ΔS_{liv} : difference between input and output in livestock, $N_{\text{surp_urban}}$: urban
45
46 19 surplus N, N_{sew} : human excreta and sewage, $N_{\text{p_rem}}$: N removal in sewage treatment plant,
47
48 20 ΔS_{hu} : difference between input and output in human subsystem, N_{disp} : disposed animal excreta,
49
50 21 N_{ma} : animal manure, N_{resi} : crop residue, N_{harv} : crop harvest, $N_{\text{surp_up}}$: surplus N in upland,
51
52 22 $N_{\text{surp_f}}$: surplus N in forest, N_{den} : denitrification.
53
54
55
56
57
58
59
60

23

1 Figure 3 Temporal dynamics of precipitation, snow depth, air temperature, and river runoff at
2 'A' drainage basin and various forms of N concentration in river water for five drainage basins
3 during a two-year period. TN: total nitrogen, TDN: total dissolved nitrogen, DON: dissolved
4 organic nitrogen, PON: particulate organic nitrogen.

6 Figure 4 Relationship between the net nitrogen input (NNI) and export of nitrogen fractions
7 among five drainage basins in 2003 and 2004. The dashed lines represent 95% confidence
8 limits. Alphabets in the figures ('A', 'B', 'C', 'D' and 'E') represent each drainage basin. TN:
9 total nitrogen, TDN: total dissolved nitrogen, DON: dissolved organic nitrogen, PON:
10 particulate organic nitrogen.

12 Figure 5 Relationship between the net nitrogen input (NNI) and export of fractions of nitrogen
13 in total nitrogen (TN) among five drainage basins in 2003 and 2004. Alphabets in the figure
14 ('A', 'B', 'C', 'D' and 'E') represent each drainage basin. DON: dissolved organic nitrogen,
15 PON: particulate organic nitrogen.

17 Figure 6 Relationship between the re-deposition rate of volatilized NH_3 to the SRC and the
18 change in NNI and riverine TN export / NNI. Values are two-year averages. $N_{\text{dep_am}}$:
19 re-deposition of volatilized NH_3 , N_{am} : NH_3 volatilization. Changed NNI (%) = $[\text{NNI}(\alpha) - \text{NNI}$
20 $(\alpha=100\%)] / \text{NNI}(\alpha=100\%) \cdot 100$.

Table 1 Characteristics of five drainage basins within the Shibetsu River catchment

Catchment	Latitude† Longitude†		Drainage Area km ²	Land Use			
	North degree	East degree		Upland %	Urban %	Wasteland %	Forest %
A	43.634	145.085	679	51.4	1.4	1.6	45.6
B	43.540	144.762	76	14.7	0.1	0.1	85.1
C	43.525	144.833	28	52.2	0.0	1.9	45.9
D	43.544	144.865	9.3	90.3	0.0	0.5	9.3
E	43.606	144.755	2.9	0.0	0.0	0.0	100

†Latitude and longitude represents location of each monitoring station.

Table 2 Nitrogen contents of crop yield and residue, and basic data for the estimation of nitrogen contents for each type of land use

Land use type	Crop yield†		Moisture content		Dry matter ratio¶	Protein concentration		Nitrogen content			
	2003	2004	Yield‡	Residue§		Residue/Yield	Yield‡	Residue§	Yield		Residue
					Mg fresh matter ha ⁻¹ yr ⁻¹				%		%
Grass	33.0	37.5	81.0	-	0	2.35	-	125	143	-	-
Maize	50.8	59.6	89.7	-	0	1.3	-	106	124	-	-
Sugar beet	48.1	61.6	86.4	83.3	40	2.2	2.7	169	217	67	86
Potato	33.3	35.1	79.5	85.5	40	2.0	2.2	107	112	66	69
Japanese radish	45.4	50.4	94.5	88.8	60	0.8	2.8	58	65	60	67

†Hokkaido Statistics and Information Office (2004, 2005).

‡Hokkaido Agricultural Experiment Station, Tenpoku and Konsen Branches (2000) for grass; Agriculture Forestry and Fisheries Research Council Secretariat, MAFF (1995) for maize; Resources Council, STA (1982) for sugar beet, potato, and Japanese radish.

§Forestry and Fisheries Research Council Secretariat, MAFF (1995).

¶Resources Survey Laboratory, STA (1982).

Table 3 Nitrogen input and output, ammonia emission factor, and manure utilization ratio in livestock subsystem

Livestock	N input	N output			Bedding litter#	Ammonia emission factor††	Manure utilization ratio‡‡
		Excretion‡	Production§	ΔS_{liv} per animal¶			
	N demand†	kg N head ⁻¹ yr ⁻¹			kg N head ⁻¹ yr ⁻¹	% excretion	%
Dairy cattle	159.4	111.5	36.1	11.8	1.3	25.5	96
Young cattle§§	47.8	35.1		12.7	0.4	25.5	96
Beef cattle	75.7	50.6	18.1	7.0	4.5	17.3	68
Pig	8.4	12.5	5.3	-9.4	0.1	36.0	62
Poultry	1.0	1.2	0.4	-0.6	0.0	36.0	0
Horse	38.3	38.3	3.5	-3.5	0.3	16.9	100

†Hokkaido Statistics and Information Office (2004) for dairy cattle; Nagumo (2000) for beef cattle, pig, poultry, and horse.

‡Tsuiki and Harada (1997).

§Production of dairy cattle was calculated by multiplying the amount of milk production (Hokkaido Statistics and Information Office 2004, 2005) and N concentration of milk. Data on production of dairy cattle represents an average in 2003 and 2004; Hokkaido Statistics and Information Office (2004) for beef; Nagumo (2000) for pig, poultry, and horse.

¶ ΔS_{liv} per animal = N demand - Excretion - Production.

Nagumo (2000).

††Bouwman *et al.* (1997).

‡‡Hokkaido Statistics and Information Office (2004) for dairy cattle, beef cattle, pig; Nagumo (2000) for poultry and horse.

§§N demand and bedding litter of young cattle was assumed to multiply the values of dairy cattle by the factor 0.3.

Table 4 Annual nitrogen flow for the Shibetsu River catchment ('A' drainage basin) in 2003 and 2004

			2003	2004	Average
			kg N ha ⁻¹ yr ⁻¹		
Watershed	Input:	Chemical fertilizer (N _{chem})	32.4	32.4	32.4
		Agricultural N fixation (N _{fix})	13.4	13.4	13.4
		DIN deposition (N _{dep})	2.2	1.6	1.9
		Imported food (N _{imfo})	1.1	1.1	1.1
		Imported feed (N _{imfe})	41.5	34.7	38.1
		Sum	90.6	83.2	86.9
	Output:	Exported food and feed (N _{exp})	24.4	25.0	24.7
		Exported ammonia (N _{exp_am})	0.00	0.00	0.00
		ΔS _{hu} †	0.00	0.00	0.00
		ΔS _{liv}	7.6	7.6	7.6
		Sum	32.0	32.6	32.3
NNI (Input - Output)			58.5	50.6	54.6
Internal budget	Upland surplus N (N _{surp_up})		52.9	45.3	49.1
	Urban surplus N (N _{surp_urban})		1.1	1.1	1.1
	Forest surplus N (N _{surp_f})		1.0	0.8	0.9
	Disposal livestock excreta (N _{disp})		3.5	3.4	3.4
NNI (N _{surp_up} + N _{surp_urban} + N _{surp_f} + N _{disp})			58.5	50.6	54.6
Urban	Input:	Imported food (N _{imfo})	1.1	1.1	1.1
		Self-supported food (N _{sel_fo})	0.03	0.03	0.03
		DIN deposition to urban (N _{dep_urban})	0.03	0.02	0.03
		Sum	1.1	1.1	1.1
	Output:	Excreta and sewage (N _{sew})	1.1	1.1	1.1
		ΔS _{hu} (N _{imfo} + N _{sel_fo} - N _{sew})	0.00	0.00	0.00
		N _{surp_urban} (N _{dep_urban} + N _{sew})	1.1	1.1	1.1
N removal in a sewage treatment plant (N _{p_rem})		0.6	0.6	0.6	
Livestock	Input:	Imported feed (N _{imfe})	41.5	34.7	38.1
		Self-supported feed (N _{sel_fe})	60.4	68.7	64.6
		Bedding litter (N _{litter})	1.2	1.1	1.2
		Sum	103.1	104.6	103.8
	Output:	Livestock excreta (N _{exc})	71.6	72.7	72.1
		NH ₃ volatil. from livestock excreta (N _{am_exc})	17.9	18.2	18.0
		Disposal livestock excreta (N _{disp})	3.5	3.4	3.4
		Livestock production (N _{pro_liv})	22.7	23.2	22.9
		Bedding litter (N _{litter})	1.2	1.1	1.2
		Sum	95.4	97.0	96.2
ΔS _{liv} (Input - Output)		7.6	7.6	7.6	
Upland	Input:	Chemical fertilizer (N _{chem})	32.4	32.4	32.4
		Agricultural N fixation (N _{fix})	13.4	13.4	13.4
		DIN deposition to upland (N _{dep_up})	1.1	0.8	1.0

1					
2					
3					
4		NH ₃ re-deposition (N _{dep_am})	20.1	20.4	20.3
5		Animal manure (N _{ma})	51.4	52.2	51.8
6		Crop residues (N _{resi})	0.15	0.16	0.15
7					
8		Sum	118.6	119.4	119.0
9	Output:	Crop harvest (N _{harv})	63.3	71.7	67.5
10		Crop residues (N _{resi})	0.15	0.16	0.15
11		NH ₃ volatil. from chem. fertil. (N _{am_chem})	2.3	2.3	2.3
12					
13		Sum	65.7	74.1	69.9
14		Upland surplus (N _{surp_up})	52.9	45.3	49.1
15					
16	Forest	Input: DIN deposition to forest (N _{dep_f})	1.05	0.76	0.90
17		Forest surplus (N _{surp_f})	1.05	0.76	0.90
18					
19					
20					
21					
22					
23					
24					
25					
26					
27					
28					
29					
30					
31					
32					
33					
34					
35					
36					
37					
38					
39					
40					
41					
42					
43					
44					
45					
46					
47					
48					
49					
50					
51					
52					
53					
54					
55					
56					
57					
58					
59					
60					

Table 5 Net nitrogen input (NNI) in and riverine nitrogen export (unit: kg N ha⁻¹ yr⁻¹) from five drainage basins

Year	Drainage basin	Upland surplus N (N _{surp_up})	Urban surplus N (N _{surp_urban})	Forest surplus N (N _{surp_f})	Disposal excreta (N _{disp})	NNI [†]	Riverine export [‡]					
							TN	TDN	NO ₃ -N	NH ₄ -N	DON	PON
2003	A	52.9	1.1	1.0	3.5	58.5	16.0	10.6	7.0	0.20	3.4	5.4
	B	15.1	0.1	1.9	1.0	18.1	8.7	5.6	3.2	0.13	2.4	3.1
	C	53.8	0.0	1.1	3.5	58.4	39.1	18.5	12.1	0.23	6.2	20.6
	D	93.0	0.0	0.2	6.1	99.3	36.1	23.3	17.3	0.10	5.8	12.9
	E	0.0	0.0	2.2	0.0	2.2	4.1	1.8	0.8	0.17	0.8	2.3
2004	A	45.3	1.1	0.8	3.4	50.6	8.6	7.4	4.9	0.28	2.2	1.1
	B	13.0	0.1	1.4	1.0	15.4	7.5	5.1	3.9	0.22	0.9	2.5
	C	46.0	0.0	0.8	3.5	50.3	30.6	13.6	10.5	0.13	2.9	17.0
	D	79.6	0.0	0.2	6.0	85.8	14.6	12.9	10.1	0.06	2.7	1.6
	E	0.0	0.0	1.6	0.0	1.6	4.9	1.9	0.9	0.15	0.8	3.0

[†]NNI = N_{surp_up} + N_{surp_urban} + N_{surp_f} + N_{disp} + N_{den_up}

[‡]NO₂-N export was not detected.

Appendix 1 H-Q equations for an estimation of river runoff in the four drainage basins

	H-Q equation: $Q = aH^2 + bH + c$					Mean relative error‡	
	n	a	b	c	r^2	P	%
B	9	46.1	-3.22	1.49	0.908	<0.001	-3.69
C	9	60.2	-9.40	0.76	0.976	<0.001	-1.26
D	11	19.0	0.30	0.14	0.776	0.0025	-2.88
E	5	13.5	-0.41	0.08	0.689	0.31	-44.66

†H: water level (m), Q: river runoff ($\text{m}^3 \text{s}^{-1}$)

‡Mean relative error (Nakasone *et al.*, 1997): $E_m = \sum [(Q_m - Q_p) / Q_m] / N$, where Q_m and Q_p are a measured runoff and a predicted runoff by a H-Q equation, respectively. N is number of samples.

For review

Appendix 2 L-Q equations for TN, TDN, and NO₃-N in the five drainage basins in 2003

		L-Q equation: $L = aQ^b$ †				P	E_m ‡	Term
		n	a	b	r^2			
A	TN	235	0.15	1.63	0.86	<0.001	-5.91	2003/1/1-2003/3/19, 2003/6/1-2003/12/31
	TDN	235	0.44	1.20	0.93	<0.001	-1.50	2003/1/1-2003/3/19, 2003/6/1-2003/12/31
	NO ₃ -N	235	0.42	1.07	0.92	<0.001	-1.36	2003/1/1-2003/3/19, 2003/6/1-2003/12/31
	TN	73	0.44	1.33	0.86	<0.001	-2.47	2003/3/20-2003/5/31
	TDN	73	1.11	1.00	0.83	<0.001	-1.93	2003/3/20-2003/5/31
	NO ₃ -N	49	0.14	1.51	0.93	<0.001	-0.46	2003/3/20-2003/5/31
B	TN	189	0.13	2.22	0.80	<0.001	-8.48	2003/1/1-2003/12/31
	TDN	188	0.26	1.46	0.76	<0.001	-5.20	2003/1/1-2003/12/31
	NO ₃ -N	189	0.15	1.45	0.74	<0.001	-6.53	2003/1/1-2003/12/31
C	TN	147	1.81	1.41	0.95	<0.001	-2.54	2003/1/1-2003/3/19, 2003/6/1-2003/12/31
	TDN	170	1.48	0.96	0.97	<0.001	-0.57	2003/1/1-2003/3/19, 2003/6/1-2003/12/31
	NO ₃ -N	170	1.03	0.82	0.95	<0.001	-0.76	2003/1/1-2003/3/19, 2003/6/1-2003/12/31
	TN	69	1.69	1.12	0.95	<0.001	-0.75	2003/3/20-2003/5/31
	TDN	69	1.57	0.91	0.92	<0.001	-0.79	2003/3/20-2003/5/31
	NO ₃ -N	45	1.12	0.74	0.84	<0.001	-0.34	2003/3/20-2003/5/31
D	TN	124	4.89	1.53	0.96	<0.001	-1.01	2003/1/1-2003/12/31
	TDN	124	2.09	0.97	0.94	<0.001	-0.70	2003/1/1-2003/12/31
	NO ₃ -N	124	1.46	0.90	0.94	<0.001	-0.61	2003/1/1-2003/12/31
E	TN	169	5.77	2.42	0.69	<0.001	-31.13	2003/1/1-2003/12/31
	TDN	170	0.42	1.45	0.43	<0.001	-44.86	2003/1/1-2003/12/31
	NO ₃ -N	170	0.30	1.69	0.64	<0.001	-14.20	2003/1/1-2003/12/31

†L: load (g N s⁻¹), Q: river runoff (m³ s⁻¹)

‡Mean relative error (Nakasone *et al.*, 1997): $E_m = \sum [(L_m - L_p) / L_m] / N$, where L_m and L_p are a measured load and a predicted load by a L-Q equation, respectively. N is number of samples.

Appendix 3 L-Q equations for TN, TDN, and NO₃-N in the five drainage basins in 2004

		n	L-Q equation: $L = aQ^b \dagger$			P	Mean relative error‡ %	Term
			a	b	r ²			
A	TN	123	0.05	2.07	0.73	<0.001	-2.80	2004/1/1-2004/3/31, 2004/6/1-2004/12/31
	TDN	123	0.51	1.17	0.57	<0.001	-1.78	2004/1/1-2004/3/31, 2004/6/1-2004/12/31
	NO ₃ -N	123	0.73	0.89	0.42	<0.001	0.73	2004/1/1-2004/3/31, 2004/6/1-2004/12/31
	TN	29	1.97	0.90	0.66	<0.001	-2.16	2004/4/1-2004/5/10
	TDN	29	1.61	0.93	0.80	<0.001	-1.08	2004/4/1-2004/5/10
	NO ₃ -N	29	0.31	1.28	0.95	<0.001	-0.52	2004/4/1-2004/5/10
	TN	23	0.39	VWM§				2004/5/11-2004/5/30
	TDN	23	0.30	VWM				2004/5/11-2004/5/30
	NO ₃ -N	18	0.13	VWM				2004/5/11-2004/5/30
B	TN	166	0.50	1.47	0.64	<0.001	-4.69	2004/1/1-2004/4/2, 2004/5/25-2004/12/31
	TDN	166	0.50	1.18	0.69	<0.001	-2.41	2004/1/1-2004/4/2, 2004/5/25-2004/12/31
	NO ₃ -N	166	0.44	0.83	0.38	<0.001	-4.44	2004/1/1-2004/4/2, 2004/5/25-2004/12/31
	TN	47	0.50	1.26	0.83	<0.001	-1.92	2004/4/3-2004/5/12
	TDN	47	0.67	0.82	0.72	<0.001	-1.43	2004/4/3-2004/5/12
	NO ₃ -N	47	0.24	1.35	0.86	<0.001	-1.72	2004/4/3-2004/5/12
	TN	23	0.27	1.23	0.82		-2.97	2004/5/13-2004/5/24
	TDN	23	0.13	VWM				2004/5/13-2004/5/24
	NO ₃ -N	23	0.04	VWM				2004/5/13-2004/5/24
C	TN	59	2.32	1.38	0.92	<0.001	31.06	2004/1/1-2004/3/31, 2004/5/1-2004/12/31
	TDN	59	1.61	0.99	0.93	<0.001	-3.23	2004/1/1-2004/3/31, 2004/5/1-2004/12/31
	NO ₃ -N	59	1.23	1.05	0.84	<0.001	-9.27	2004/1/1-2004/3/31, 2004/5/1-2004/12/31
	TN	20	2.43	1.52	0.95	<0.001	-1.72	2004/4/1-2004/4/15
	TDN	20	1.50	0.90	0.99	<0.001	-2.29	2004/4/1-2004/4/15
	NO ₃ -N	20	0.99	0.90	0.99	<0.001	0.33	2004/4/1-2004/4/15
	TN	25	4.95	2.13	0.93	<0.001	-14.51	2004/4/16-2004/4/30
	TDN	25	1.64	0.98	0.92	<0.001	-2.09	2004/4/16-2004/4/30
	NO ₃ -N	25	1.35	0.99	0.81	<0.001	-13.43	2004/4/16-2004/4/30
D	TN	110	2.74	1.15	0.86	<0.001	-0.68	2004/1/1-2004/4/2, 2004/5/13-2004/12/31
	TDN	110	1.64	0.91	0.88	<0.001	-0.37	2004/1/1-2004/4/2, 2004/5/13-2004/12/31
	NO ₃ -N	110	0.98	0.76	0.75	<0.001	-0.61	2004/1/1-2004/4/2, 2004/5/13-2004/12/31
	TN	44	4.77	1.47	0.95	<0.001	-0.56	2004/4/3-2004/4/18
	TDN	41	3.14	1.27	0.91	<0.001	-0.69	2004/4/3-2004/4/18
	NO ₃ -N	44	3.18	1.42	0.87	<0.001	-1.52	2004/4/3-2004/4/18
	TN	24	2.57	VWM				2004/4/19-2004/5/12
	TDN	24	2.29	VWM				2004/4/19-2004/5/12

	NO ₃ -N	24	1.80	VWM				2004/4/19-2004/5/12
E	TN	123	8.19	2.37	0.75	<0.001	-22.92	2004/1/1-2004/12/31
	TDN	122	0.95	1.75	0.49	<0.001	-72.83	2004/1/1-2004/12/31
	NO ₃ -N	102	0.16	1.27	0.65	<0.001	-11.04	2004/1/1-2004/12/31

†L: load (g N s⁻¹), Q: river runoff (m³ s⁻¹)

‡Mean relative error (Nakasone *et al.*, 1997): $E_m = \sum [(L_m - L_p) / L_m] / N$, where L_m and L_p are a measured load and a predicted load by a L-Q equation, respectively. N is number of samples.

§Volume weighted mean concentration (mg N L⁻¹).

For review

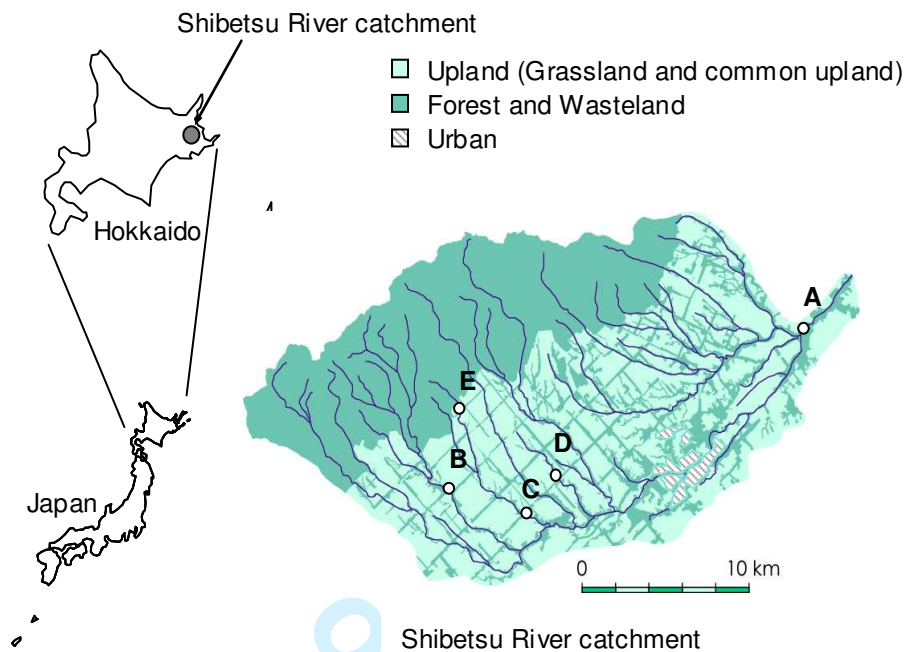

Figure 1 Land use types and five drainage basins in the Shibetsu River catchment, Hokkaido, Japan. The circles inside the catchment represent monitoring stations. Sampling of river water and atmospheric DIN deposition and monitoring of water level were conducted at each monitoring station. There is a large shelterbelt of lattice forest surrounding the grassland.

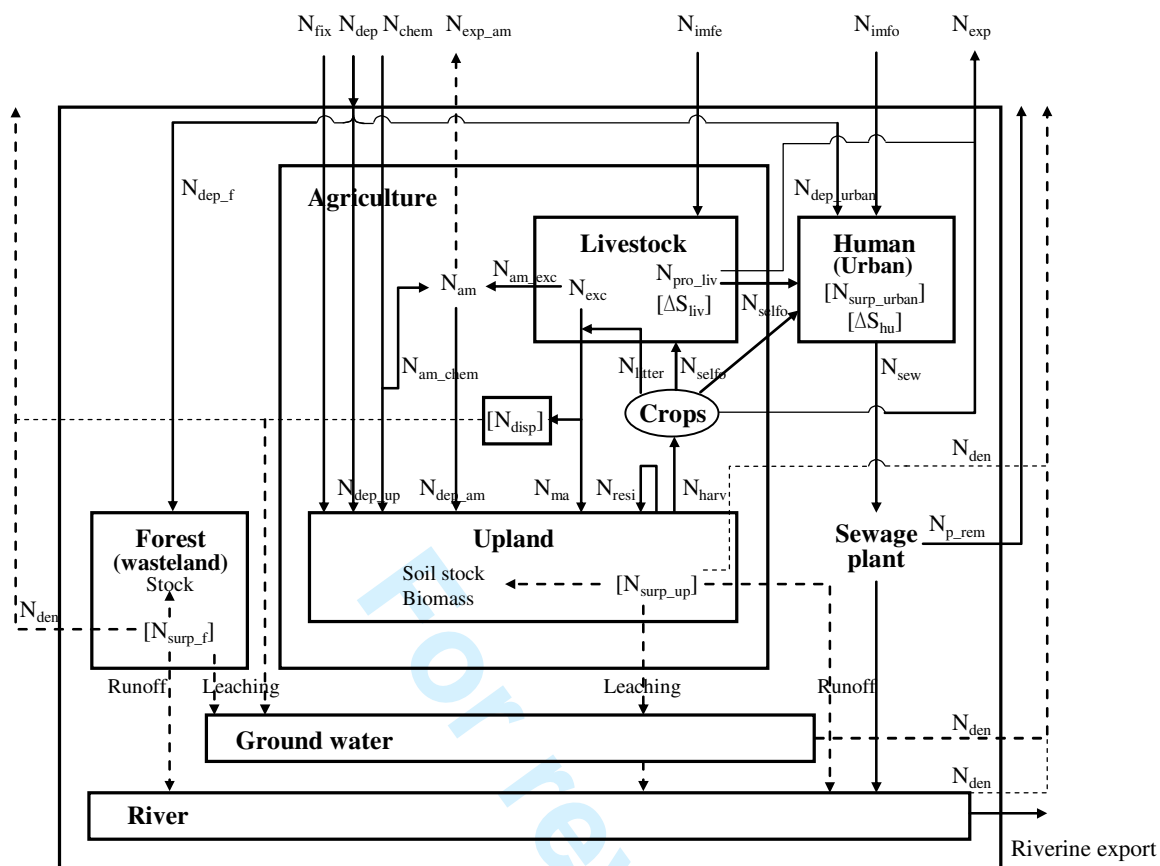

Figure 2 Nitrogen (N) fluxes from, to, and within the Shibetsu River catchment: The solid arrows represent N flows we calculated and the dotted arrows represent N flows we did not consider in this study. N_{fix} : agricultural N fixation by leguminous and non-leguminous crops, N_{chem} : chemical fertilizer, N_{dep} : atmospheric DIN (NH_4 -N+ NO_3 -N) deposition to whole watershed, N_{imfe} : imported feed, N_{imfo} : imported food, N_{exp} : exported food and feed, N_{exp_am} : exported NH_3 , N_{dep_f} : atmospheric DIN deposition to forest, N_{dep_up} : atmospheric DIN deposition to upland, N_{dep_urban} : atmospheric DIN deposition to urban, N_{am} : NH_3 volatilization, N_{am_chem} : NH_3 volatilization from chemical fertilizer, N_{am_exc} : NH_3 volatilization from livestock excreta, N_{dep_am} : re-deposition of volatilized- NH_3 to upland, N_{exc} : livestock excreta, N_{litter} : bedding litter, N_{pro_liv} : livestock production, N_{self_fo} : self-supported food, N_{self_fe} : self-supported feed, ΔS_{liv} : difference between input and output in livestock, N_{surp_urban} : urban surplus N, N_{sew} : human excreta and sewage, N_{p_rem} : N removal in sewage treatment plant, ΔS_{hu} : difference between input and output in human subsystem, N_{disp} : disposed animal excreta, N_{ma} : animal manure, N_{resi} : crop residue, N_{harv} : crop harvest, N_{surp_up} : surplus N in upland, N_{surp_f} : surplus N in forest, N_{den} : denitrification.

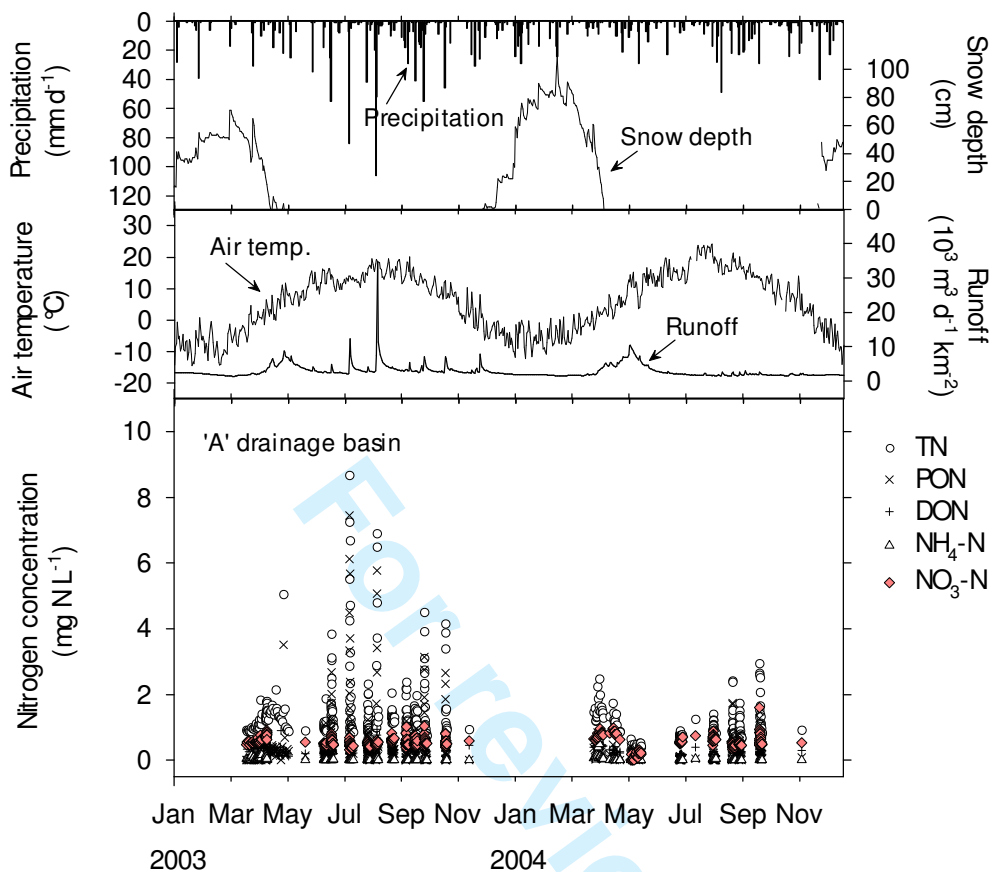

Figure 3a Temporal dynamics of precipitation, snow depth, air temperature, and river runoff at 'A' drainage basin and various forms of N concentration in river water for 'A' drainage basin during a two-year period. TN: total nitrogen, TDN: total dissolved nitrogen, DON: dissolved organic nitrogen, PON: particulate organic nitrogen.

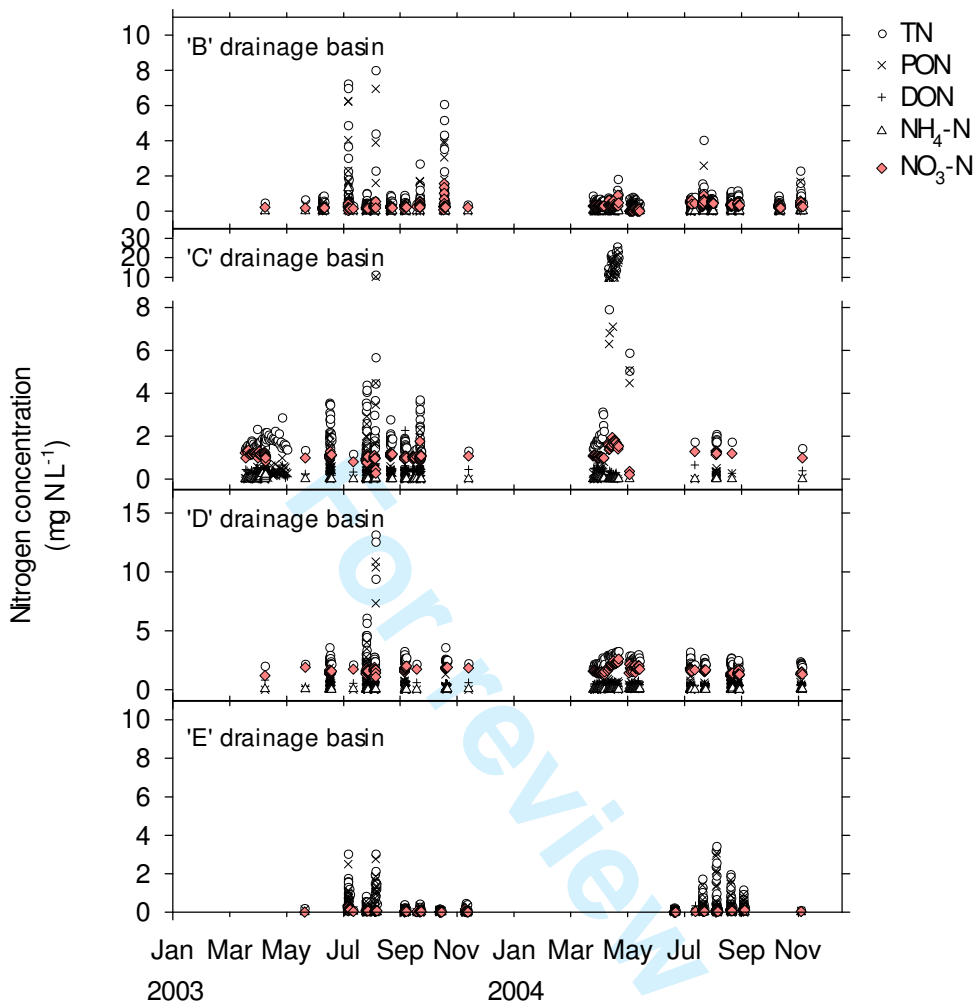

Figure 3b Temporal dynamics of various forms of N concentration in river water for 'B', 'C', 'D', and 'E' drainage basins during a two-year period. TN: total nitrogen, TDN: total dissolved nitrogen, DON: dissolved organic nitrogen, PON: particulate organic nitrogen.

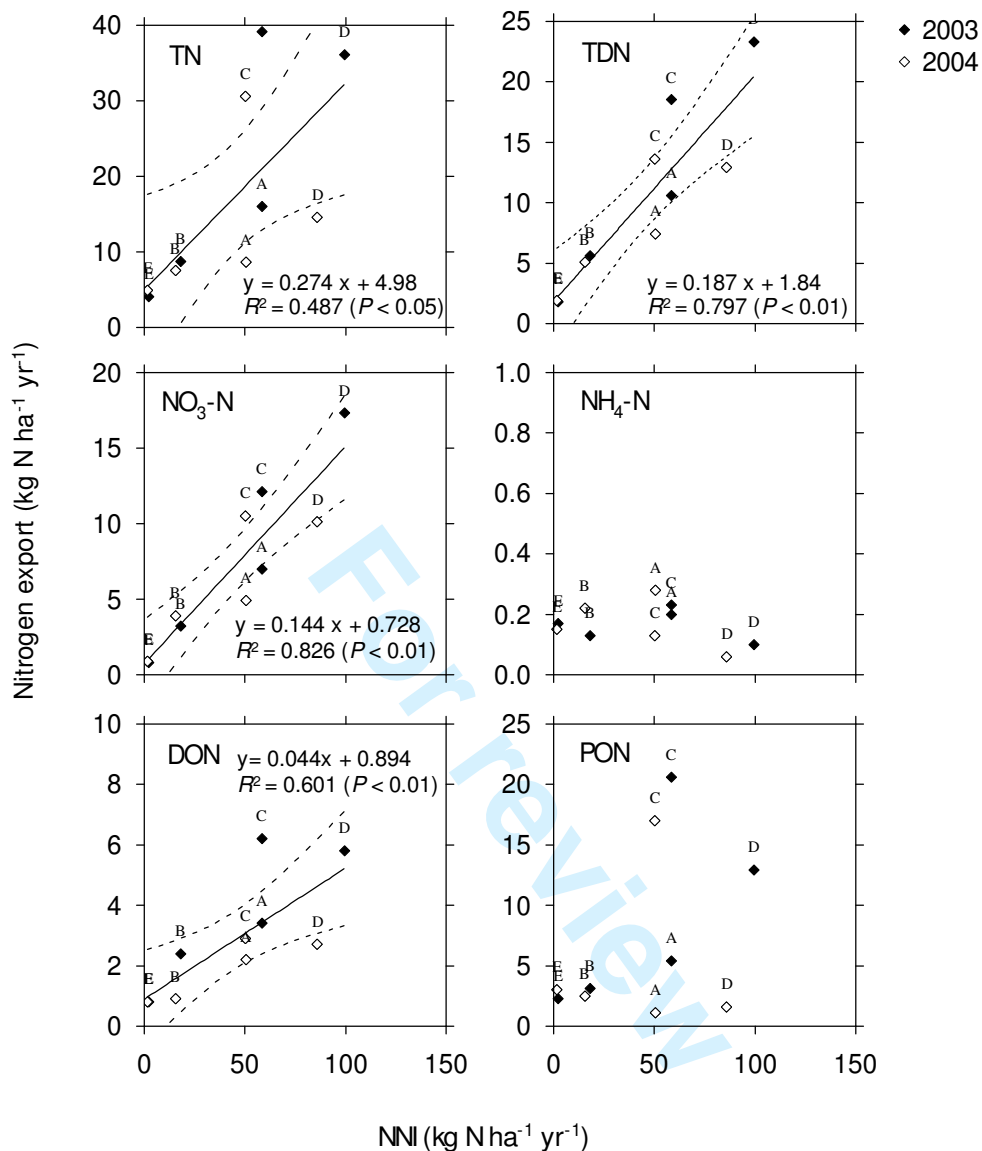

Figure 4 Relationship between the net nitrogen input (NNI) and export of nitrogen fractions among five drainage basins in 2003 and 2004. The dashed lines represent 95% confidence limits. Alphabets in the figures ('A', 'B', 'C', 'D' and 'E') represent each drainage basin. TN: total nitrogen, TDN: total dissolved nitrogen, DON: dissolved organic nitrogen, PON: particulate organic nitrogen.

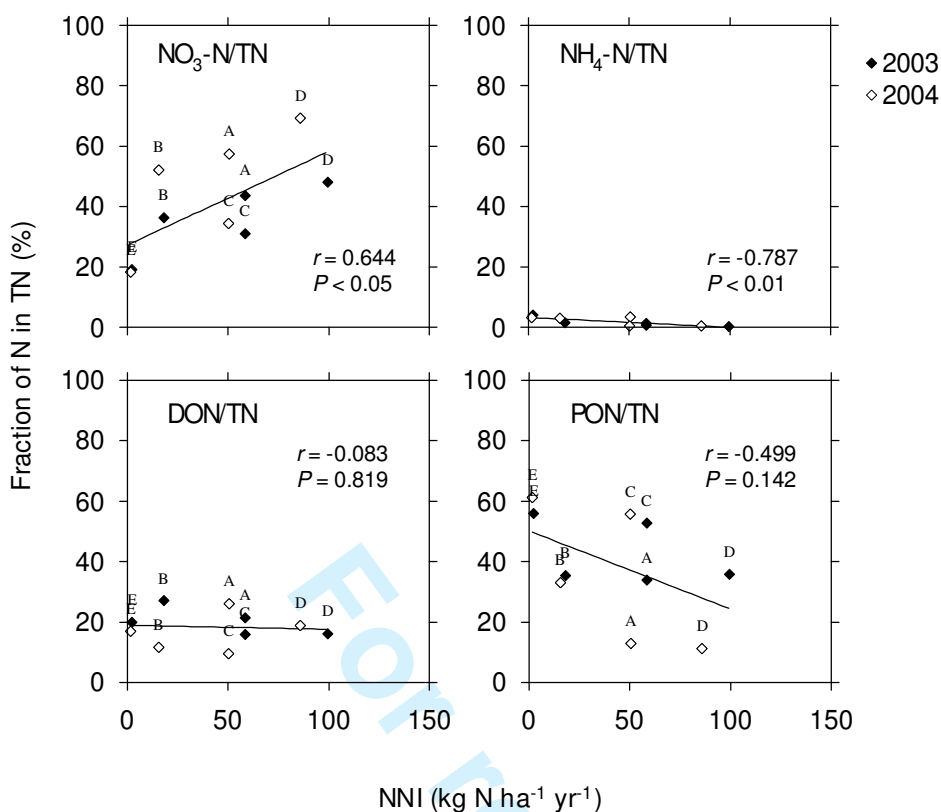

Figure 5 Relationship between the net nitrogen input (NNI) and export of fractions of nitrogen in total nitrogen (TN) among five drainage basins in 2003 and 2004. Alphabets in the figure ('A', 'B', 'C', 'D' and 'E') represent each drainage basin. DON: dissolved organic nitrogen, PON: particulate organic nitrogen.

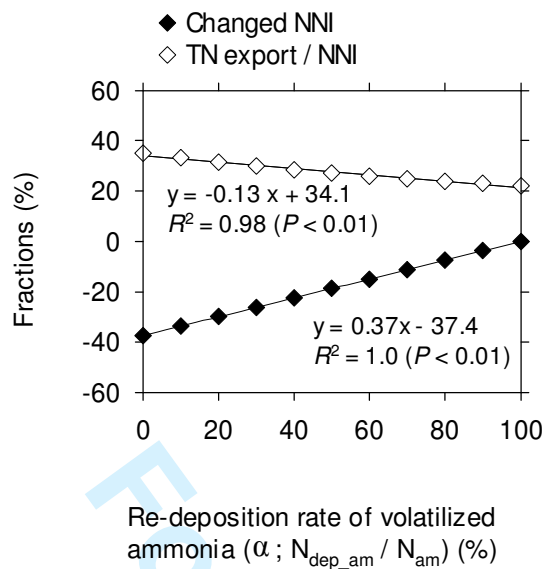

Figure 6 Relationship between the re-deposition rate of volatilized NH_3 to the SRC and the change in NNI and riverine TN export / NNI. Values are two-year averages. $N_{\text{dep_am}}$: re-deposition of volatilized NH_3 , N_{am} : NH_3 volatilization. Changed NNI (%) = $[\text{NNI}(\alpha) - \text{NNI}(\alpha=100\%)] / \text{NNI}(\alpha=100\%) \cdot 100$.