



Title	Photocatalysis A to Z : What we know and what we do not know in a scientific sense
Author(s)	Ohtani, B.
Citation	Journal of Photochemistry and Photobiology C : Photochemistry Reviews, 11(4), 157-178 https://doi.org/10.1016/j.jphotochemrev.2011.02.001
Issue Date	2010-12
Doc URL	https://hdl.handle.net/2115/47047
Type	journal article
File Information	JPPC11-4_157-178.pdf



Photocatalysis A to Z —What We Know and What We Don't Know in A Scientific Sense

B. Ohtani*

Catalysis Research Center, Hokkaido University, Sapporo 001-0021, Japan

ABSTRACT

Topics, in alphabetical order from "Activity", "Band structure" and "Crystallinity" to "X-ray photoelectron spectroscopy", "Yield" and "Z-scheme photocatalysis", related to photocatalysis and photoelectrochemical reaction are discussed with interpretation of what we know and what we don't know in a scientific sense.

Keywords: Photocatalysis; Photoelectrochemical reaction

Introduction

It seems unnecessary to explain the importance of photocatalysis in both fundamental and application studies. Since results of many studies on photocatalysis have been reported, it seems rather difficult, at least for the author, to make a complete review by introducing all or a large part of the reported studies on photocatalysis, while, of course, successful reviews [1,2,3] have been published by talented researchers in this field. This critical review has been written in order to make clear what we know and what we don't know about photocatalysis, not to compile studies on photocatalysis, based on the author's experience in studies on photocatalysis for more than twenty-five years, with apology to the readers for limiting topics to so-called

*Corresponding Author. Tel.: +81 11 706 9132; fax: +81 11 706 9133. E-mail address: ohtani@cat.hokudai.ac.jp (B. Ohtani).

semiconductor photocatalysis (See "Thermodynamics"). The topics are presented in alphabetical order with one figure for each topic. A small part of the topics overlap with those discussed in the author's recent review [4], but those topics have been revised with new figures.

Absorbance, see "Kubelka–Munk function" and "Optical band gap".

Action spectrum, see "Doping" and "Wavelength dependence".

Activation energy, see "First-order kinetics" and "Thermodynamics".

Activity

The term "activity" is often used in papers on photocatalysis as "photocatalytic activity". Although the author does not know who first started using this term in the field of photocatalysis, people involved in the field of catalysis were using this term before the 1980's, when photocatalysis studies had begun to be accelerated by the famous work of the so-called "Honda-Fujishima effect" on photoelectrochemical water splitting using a single-crystal titania electrode [5]. Most authors, including the present author, use the term "photocatalytic activity", but in almost all cases the meaning is the same as that of absolute or relative reaction rate. One reason why we like to use the term "photocatalytic activity" may be that it is possible to make readers think of "photocatalytic reaction rate" as one of the properties or abilities of a photocatalyst, i.e., photocatalysts have individual activity, while "reaction rate" is controlled by the activity under given reaction conditions. In the field of catalysis, "catalytic activity" has been used to show a property or performance of a catalyst, since an "active site" (**Fig. A**) on a catalyst accounts for the catalytic reaction. The reaction rate per active site can be estimated and should be "catalytic activity". Sometimes the term "turnover frequency", i.e., number of turnovers per unit time of reaction, is used to show how many times one active site produces a reaction product(s) within unit time. On the other hand, there are no active sites, in the same meaning used for thermal catalysis, i.e., rate of catalytic reaction is predominantly governed by the number or density of active sites, on a photocatalyst [6], and the reaction rate strongly

depends on various factors such as the intensity of irradiated light which initiates a photocatalytic reaction. Considering that the dark side of a photocatalyst or suspension does not work for the photocatalytic reaction, the use of the term "active site" is inappropriate, and a relationship of photocatalytic activities with active sites therefore cannot be expected [7].

In kinetic analysis of general chemical reactions, a rate constant is estimated and compared. Considering that photoexcited electrons (e^-) and positive holes (h^+) induce a redox reaction, it may be possible to estimate the rate constant of these active species [8]. Since e^- and h^+ recombine with each other (See "Mutual recombination"), the overall photocatalytic reaction rate depends also on this recombination rate. Assuming that $k(\text{redox})$ and $k(\text{recombination})$ are rate constants of reactions by e^- and h^+ and their recombination, respectively, i.e., the simplest kinetic model, the ratio $k(\text{redox})/k(\text{recombination})$ should be a measure of intrinsic photocatalytic activity [9]. However, unfortunately, we have no way to estimate $k(\text{recombination})$, since the recombination does not produce any chemical species to be detected for estimation of its rate [10].

Known: Rate of photocatalytic reactions under given conditions, i.e., relative photocatalytic activity and general empirical trends.

Unknown: Intrinsic photocatalytic activity, overall kinetic equation, and true correlation between physical or structural properties and photocatalytic reaction rate.

Adsorption, see "Langmuir–Hinshelwood mechanism".

Amorphous, see "Crystallinity".

Anatase, see "Crystallinity" and "Synergetic effect".

Arrhenius plot, see "Thermodynamics".

Average, see "Particle size".

Band structure (See also "Junction", "Thermodynamics" and "Visible light".)

The general understanding of the mechanism of photocatalysis is that photoabsorption of

a semiconducting material occurs to excite electrons from the valence band (VB) to the conduction band (CB) leaving positive holes in the VB, i.e., electron-hole pair (e^-h^+) generation (**Fig. B**). An important point is that photoabsorption and (e^-h^+) generation are inextricably linked; a VB electron is not excited after photoabsorption. This interband (band-to-band) excitation is often illustrated by three bands, CB, forbidden band (band gap) and VB, in which an electron moves vertically from the VB to CB, i.e., no spatial change in the position of an electron, though the author has sometimes encountered misunderstanding that an electron migrates from the VB to CB spatially. Anyway, the above-mentioned interpretation seems to be a little strange considering the meaning of band structure and band-to-band transition, in which electrons are not localized and therefore electrons and positive holes can migrate within a crystal; an unlocalized excitation state may be described as "photoexcited crystal", e.g., an excited state of titania, without showing localized e^-h^+ . Do e^- and h^+ migrate in the CB and VB, respectively, after photoabsorption, i.e., photoexcitation? When we illustrate the electronic structure of a molecule, lines are drawn to show the electronic state (**Fig. B**); the length of these lines does not mean spatial distribution of electrons in those states. This should also be the case for semiconducting (or insulating) materials, and band-to-band transition just means that an electron in the VB is excited to the CB without clarifying the location of e^- and h^+ . Sometimes we, at least the present author, misunderstand that e^- and h^+ migrate to the surface (Right or left end of the CB and VB in **Fig. B** is often assigned to "surface").

A possible interpretation of a better understanding for e^-h^+ location is that there are sites trapping e^- or h^+ in the crystal lattice and that e^- and h^+ are trapped by these sites "immediately" after the band-to-band transition, i.e., photoabsorption [11]. Location of e^- and h^+ in the initial stage of photocatalysis as well as the rate should be controlled by the density and spatial distribution of these traps in a photocatalyst. However, there is little information on the density and spatial distribution of traps, since the structure of traps has not been fully clarified. The possible surface traps may be reaction sites, but not "active sites" (See "Activity").

Fermi level is a kind of measure of equilibrium electrochemical potential of a solid

material. It is thought that Fermi level is located just below the CB bottom and above the VB top for n-type and p-type semiconducting materials [12], respectively. Most metal oxides are categorized as n-type semiconductors with Fermi levels more cathodic (higher) than the standard electrode potential of an electrolyte in contact with the metal oxide, and thereby electrons in donor levels slightly below the CB are injected into the electrolyte to form a space charge (depletion) layer with an electric field, i.e., Schottky barrier. In the 1980's, it was thought that this inner electric field separates e^- - h^+ effectively; i.e., e^- and h^+ migrate to the bulk and surfaces of semiconductor electrodes and particles, but it seems that this is not the case for untreated photocatalyst particles because of the expected large thickness of this layer due to very low density of donor levels in ordinary photocatalyst particles (See "Junction").

Known: Positions of conduction-band bottom and valence-band top of semiconducting materials and thereby band gaps.

Unknown: Photoexcited states of particulate photocatalysts, actual form of photoexcited electron and positive hole in the initial stage of photocatalysis, and mechanism of their migration.

Catalyst, see "Thermodynamics".

Crystallinity

Photocatalysts are often inorganic solid materials (See "Thermodynamics"). They are usually crystals and the crystalline form is often determined by an X-ray diffraction (XRD) pattern. One of the problems in XRD analyses is that only crystals are detected, while an amorphous part, if present in samples, exhibits no diffraction peaks. Halo may appear for amorphous parts, but there has been no report showing quantitative determination of amorphous content. Thus, amorphous content must be determined as a rest of crystalline part and therefore precise determination of crystalline content is necessary. It is believed that, in principle, XRD peak intensity is proportional to content of corresponding crystallites, but a problem is how we can get global standard samples of each crystal, because smaller crystallites may exhibit lower

peak intensity [13]. A possible interpretation of this problem is that the outermost surface of particles can not be involved in a crystal, which can be defined only for bulk, and the ratio of surface/bulk becomes appreciable when the size of crystallites becomes small. Thus, precise analysis of crystalline content can be guaranteed when pure crystalline particles included in a sample are extracted and used for making an XRD calibration curve [14,15] based on the assumption that crystallites and amorphous particles are separated, but not in the form of, for example, a core-shell structure (**Fig. C**). In other words, if a sample particle is of a core-shell structure, precise determination of crystalline content may be very difficult.

Confusion regarding the term "crystallinity" arises because the term is discussed on the basis of sharpness of an XRD peak, e.g., "Sharpness of the peak indicated higher crystallinity of a photocatalyst." Since the width of an XRD peak reflects the size of a particle, i.e., the depth of crystallites measured in the direction vertical to a corresponding lattice plane (Scherrer equation (See "Particle size".)) [16,4], peak sharpness shows the size of crystallites. In this sense, "crystallinity" is used to show how crystallites grow to be larger-sized particles. Another usage of the term "crystallinity" is to show perfectness of crystals, i.e., higher crystallinity means lesser density of crystalline defects. As mentioned above, sharpness of XRD peaks might be a measure of crystallite size. Assuming that larger crystallites possess smaller density of crystalline defects, sharpness of XRD peaks can also be a relative measure of "crystallinity".

Known: Relative extent of crystal growth.

Unknown: Methods for determination of precise composition of crystals and actual structure of an amorphous phase.

Defect, see "Doping", "Hydroxyl radical", "Nanostructure" and "Visible light-induced photocatalysis".

Doping (See also "Visible light-induced photocatalytic activity".)

Since the discovery of visible light-induced activity of nitrogen-containing titania

particles by Asahi et al. [17], "doping" has been a keyword for fabrication of visible light-sensitive photocatalysts; any photocatalysts with poor visible-light activity can be modified with metal or non-metal elements to be active under visible-light irradiation. There seems to be two reasons for the explosive growth in the number of papers on doped material. One might be a lack of methodology to prove visible light-induced photocatalysis, as discussed in the last part of this section. Another reason is an unclear definition of the term "doping". As far as the author knows, the meaning of "doping" is incorporation of atoms or ions in a crystalline lattice, i.e., modification of the bulk structure of crystallites, but not modification of surfaces. However, as far as the author knows, such location of hetero atoms or ions has been negligibly discussed. If an adequate analytical method(s), if any, is(are) employed, average density of hetero atoms/ions can be determined, and if mapping of elements can be performed with higher sensitivity, spatial distribution may be elucidated. The effect of doping must be discussed on the basis of this structural information, though there have been few reports containing such discussion so far. In relation to this problem, recent papers have claimed that heptazine derivatives are produced on the surface of titania particles in the procedure for nitrogen doping using urea as a nitrogen source and that they work as a photosensitizer and/or photocatalyst [18], i.e., nitrogen is not "doped" in the titania lattice but is included as a surface modifier.

Even if introduced hetero atoms/ions are not "doped" in the lattice, it is useful to prepare modified photocatalysts with visible-light absorption by introducing hetero atoms/ions. One problem, however, is that newly appearing visible-light photoabsorption and photoinduced reaction rate under visible-light photoirradiation are often described in papers. As the author's group reported, the use of organic dyes for a photoinduced degradation test is inappropriate because those dyes might be adsorbed and work as visible-light photosensitizers, and it is preferable to show resemblance of absorption (diffuse reflection) and actions spectra, i.e., photocatalysis by doped (modified) photocatalysts can be proved through action spectrum analysis (See "Wavelength dependence"). **Figure D** presents representative results proving visible-light response of sulfur-doped titania [19], as a rare case among studies on visible

light-sensitive photocatalysts, showing the resemblance of a diffuse-reflectance spectrum with an action spectrum for photocatalytic oxidative decomposition of acetic acid in aerated aqueous solution; doping of (or at least modification with) sulfur induced photoabsorption and photocatalytic activity in the visible-light region.

Known: Something included in samples.

Unknown: Methods for determination of the precise structure, density and spatial distribution of doped materials and of the effect of doping.

Energy conversion (See also "Gibbs energy" and "Thermodynamics")

Photocatalytic and photoelectrochemical cleavage of water produces hydrogen (H_2), as an ideal fuel emitting only water, and oxygen (O_2), and many researchers are trying to establish a highly efficient system for water splitting under solar radiation. Since this reaction requires input of energy due to its positive Gibbs energy, energy of light is used. The efficiency of conversion of light energy to chemical energy thus becomes important [20]. It should be noted that there are at least two kinds of methods for calculation of the efficiency: number (molar amount)-based and energy-based methods. The former is the same as "quantum efficiency", which is calculated as a number ratio of product(s) and photons absorbed by (quantum efficiency) or incident on the reaction system (apparent quantum efficiency; ϕ in **Fig. E**). For discussion of energy conversion, the latter energy-based calculation should be used. Since the energy of H_2 (and O_2) shown in the difference in electrochemical potential, i.e., electromotive force (emf), is 1.23 eV, energy conversion efficiency is 100% when light of 1.23-eV energy (ca. 1000-nm wavelength) is absorbed completely by a photocatalyst and all liberated e^- and h^+ are used for water cleavage. The most significant point of photocatalysis and photoelectrochemical reaction is that even if light of energy much greater than the band gap of semiconducting materials as a photocatalyst or photoelectrode is used, potential of e^- and h^+ is fixed at the position of the CB bottom and VB top, respectively. Therefore, the energy conversion efficiency is halved when 2.46-eV light (504 nm) is used with constant apparent quantum efficiency (**Fig. E (a)**).

Although it is often claimed that extension of the limiting wavelength of absorption by photocatalysts and photoelectrodes is necessary to utilize solar energy more efficiently (See "Doping" and "Visible light-induced photocatalysis"), relatively low energy-conversion efficiency at a shorter wavelength has still not been improved. It should also be pointed out that there is a limitation of the longer wavelength side depending on the reaction to drive, e.g., ca. 1000 nm at longest for water splitting as described above [21].

There is still a problem in calculation of energy conversion efficiency when electrochemical or chemical bias is also applied in photoelectrochemical or photocatalytic reaction of positive Gibbs energy. For example, as shown in **Fig. E (c)**, energy conversion efficiency for a photoelectrochemical system consisting of an n-type semiconductor and metal counter electrodes with bias voltage Δb , in a unit of eV (as potential energy of an electron in an electric field with bias voltage b V), is possibly expressed as follows.

$$(\text{energy conversion efficiency}) = \phi \frac{\Delta G - \Delta b}{E_{\text{photon}}}. \quad (\text{ea. E})$$

However, the reasonability of this calculation has been scarcely discussed so far.

Known: Method for calculating energy conversion efficiency for a simple non-biased photocatalytic or photoelectrochemical system and limitation of energy conversion efficiency using material absorbing longer wavelength light due to lower efficiency for shorter wavelength region.

Unknown: An appropriate method for calculation of energy conversion efficiency for electrochemically or chemically biased systems.

First-order kinetics (See also "Langmuir-Hinshelwood mechanism".)

It is well known that first-order kinetics is commonly observed for reactions occurring in homogeneous phases, i.e., reactions in homogeneous solutions or in gas phase. Ideally, the rate of a monomolecular reaction obeys a first-order rate expression that is explained by that

proportion (number) of molecules having kinetic energy larger than the activation energy is determined only by temperature of the reaction, and that the actual number of molecules with energy for activation is proportional to the concentration (or pressure) of molecules. For these reactions, kinetic data are analyzed by plotting the logarithm of concentration of a substrate or a product against time of the reaction [22] to obtain a linear line, and absolute value of the slope of the line is a rate constant, k (**Fig. F**). The rate (r) of consumption of a substrate (A) is shown by the following equation.

$$r = -\frac{d[A]}{dt} = k[A]. \quad (\text{eq. F})$$

On the other hand, kinetics of reactions occurring on a solid surface, i.e., catalysis or photocatalysis, must be significantly different. There are two representative extreme cases. One is the so-called "diffusion controlled" process, in which surface reactions and the following detachment process occur very rapidly to give a negligible surface concentration of adsorbed molecules, and the overall rate coincides with the rate of adsorption of substrate molecules. In this case, the overall rate is proportional to concentration of the substrate in a solution or gas phase (bulk), i.e., first-order kinetics is observed [23]. The other extreme case is the so-called "surface-reaction limited" process, in which surface adsorption is kept in equilibrium during the reaction and the overall rate coincides with the rate of reaction occurring on the surface, i.e., reaction of e^- and h^+ with surface-adsorbed substrate [24]. Under these conditions, the overall rate is not proportional to concentration of the substrate in the bulk unless the adsorption isotherm obeys a Henry-type equation, in which the amount of adsorption is proportional to concentration in the bulk [25]. In the former case, the rate of photocatalytic reaction obeys the first-order rate law, but this is only formal and does not mean the mechanism of monomolecular reaction with activation energy.

One of the most significant points that we must consider in scientific studies, not limited to studies on photocatalysis, is discrimination of "evidence" and "consistency", at least as far as

the author thinks. In other words, it is necessary to recognize every fact to be a "necessary condition" but not a "sufficient condition" in a strict scientific sense. For example, the fact that reaction rate obeys the first-order rate law giving a linear relation in a plot of data as in **Fig. F** is only a necessary condition for a monomolecular reaction in homogeneous phase and also a necessary condition for heterogeneous photocatalytic reaction in diffusion-limited conditions or that in surface-reaction limited conditions with a Henry-type adsorption or a Langmuir-type adsorption in the lower concentration region.

Known: Method for kinetic analysis for the first-order rate law.

Unknown: Meaning of a linear relation in a plot of logarithmic concentration of a substrate or a product against the concentration of substrate in the bulk.

Fermi level, see "Band structure" and "Junction".

Gibbs energy (See also "Band structure", "Energy conversion" and "Thermodynamics".)

Change in Gibbs energy (ΔG) of a given reaction is often discussed in chemistry. If ΔG is negative ($\Delta G < 0$, e.g., oxidative decomposition of organic compounds under aerated conditions) and positive ($\Delta G > 0$, e.g., splitting of water into hydrogen and oxygen), the reaction releases and absorbs energy, respectively, and both situations are possible for photocatalytic reactions, while ordinary catalyses are limited to reactions of negative ΔG , i.e., spontaneous reactions. In other words, a photocatalyst can drive reactions of positive ΔG , i.e., energy-storing reactions, as well as those of negative ΔG . Why can photocatalysts drive a reaction of positive ΔG which does not proceed spontaneously? The reason is that an overall redox reaction can proceed, even if its ΔG is positive, in a system in which reduction and oxidation steps are spatially or chemically separated; otherwise reaction between reduction and oxidation products proceeds to give no net products. Under these conditions, both Gibbs energy change for reactions of e^- with oxidant (ΔG_e) and h^+ with reductant (ΔG_h) are required to be negative, i.e., reactions by e^- and h^+ proceed spontaneously after photoexcitation (**Fig. G**). As discussed in

"Thermodynamics", it is often emphasized that a thermodynamic requirement for photocatalytic reaction is more cathodic and anodic levels of the CB bottom and VB top compared with the standard electrode potential of an oxidant and a reductant, respectively, to make Gibbs energy change of both reactions negative. However, this is only one of the necessary conditions and another important necessary condition, though negligibly discussed, is separation of reduction and oxidation by e^- and h^+ , respectively, for both types of reaction with positive and negative ΔG [26]. Actually, many studies have revealed "potential photocatalysts" for photoinduced water splitting using two kinds of model reaction for hydrogen and oxygen production from aqueous methanol and an aqueous solution of silver salt; production of hydrogen and oxygen in each reaction proved that positions of the CB bottom and VB top are more cathodic and anodic compared with the standard electrode potentials for H^+/H_2 and O_2/H_2O systems, respectively, though only a few photocatalysts could produce hydrogen and oxygen at the same time in the absence of sacrificial electron donors and acceptors (See "Thermodynamics").

Known: A necessary condition of band structure of a photocatalyst for photocatalytic reactions.

Unknown: (none)

Hole, see "Hydroxyl radical".

Honda-Fujishima effect, see "Activity".

Hydroxyl radical

Actually, hydroxyl radicals were detected in a suspension of titania particles under ultraviolet irradiation [27,28]. Although the author does not know from when people in this field believed that photocatalysis, especially by titania, includes oxidation of organic substrates by hydroxyl radicals that are liberated by the reaction of positive holes and surface-bound water or hydroxyl groups, the detection of hydroxyl radicals might be the reason for this misunderstanding. A problem is the difficulty in obtaining proof for a certain reaction intermediate; one acceptable way to show intermediacy of a species is to show the disappearance

of an intermediate, when a reaction substrate is added, with the rate being the same (but in the opposite direction) as that of liberation of a product. However, as far as the author knows, there have been no reports showing this for a hydroxyl radical.

Another, but significant, problem is the definition of "positive hole". Positive hole is defined as a defect of an electron (i.e., a positive hole must be included in a substance, while an electron is a real substance). Therefore, not only h^+ produced by photoinduced band-to-band transition in solid materials (See "Band structure".) but also a hydroxyl radical, which is a one-electron deficient hydroxyl anion, can be a positive hole. If this definition is accepted, there should be no difference in the photocatalytic oxidation mechanisms between "direct hole transfer" and "surface-adsorbed hydroxyl radical reaction", since it is well known that the surface of a metal oxide is covered with chemically or physically adsorbed water and a positive hole passing through this water layer into a solution may be a hydroxyl radical or its protonated or deprotonated species (**Fig. H**).

Known: Positive holes are produced in photoirradiated photocatalysts, and they may give hydroxyl radicals.

Unknown: Chemical form of positive hole at the interface.

Identification

Since photocatalytic reactions are chemical reactions, there are products to be identified. At present, no researchers in the field of photocatalysis identify inorganic gaseous compounds, such as hydrogen (H_2), oxygen (O_2) and carbon dioxide (CO_2), but, strictly speaking, all of the products of reported photocatalytic reactions must be identified. When authors claim potential application of a heterogeneous photocatalytic reaction to synthesis of compounds, isolation and identification of the product(s) are indispensable. Although organic chemists have recognized this as common sense, researchers in other fields of science should be reminded of this to avoid confusion induced when products are reported incorrectly without appropriate identification.

It is well known that chromatography cannot be used for product identification. This

can be understood by the fact that chromatographic peaks of different compounds may appear in the same retention time (volume). For example, in the author's experience during study on photocatalytic reactions of alkyl amines by platinized titania suspended in a deaerated aqueous solution, products from propylamine were analyzed by gas chromatography in which a peak appeared at almost the same elution time as that of an authentic sample of propionitrile. It seemed reasonable that propylamine gave propionitrile by oxidation with positive holes (h^+), as follows, along with hydrogen evolution, since nitriles were obtained in anodic oxidation of amines in alkaline solutions [29].

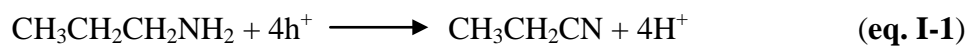

However, it was observed that FWHM (full width at half maximum) of the peak was slightly wider than that of propionitrile, and other analytical procedures such as $^1\text{H-NMR}$ and mass spectroscopy revealed that the product was dipropylamine produced via the following redox-combined process, including oxidation of an amino group in propylamine by positive holes followed by hydrolysis into propionaldehyde, condensation of the aldehyde with propylamine to yield a Schiff base intermediate, and reduction of the Schiff base by photoexcited electrons [30], i.e., peaks of propionitrile and dipropylamine appeared accidentally at the same position (retention time) in the chromatogram.

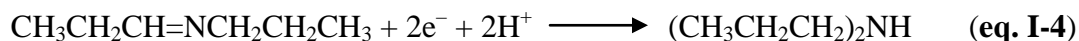
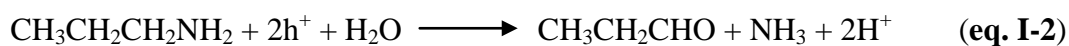

Thus, chromatographic analysis could not be used for product identification [31]. Although this seems to be generally noticed, mistakes in identification have also been made in the field of photocatalysis. It should be noted that, as well as this chromatography problem, identification cannot be completed in a strict scientific sense. Accumulation of results that are consistent with the presumed structure of a given product shows consistency but not proof; compounds are

always "almost identified" with the least possibility of another structure. Without getting sufficient condition (although such sufficient conditions can not be obtained in scientific studies; **Fig. I (a)**), accumulation of necessary conditions shows only consistency and cannot be proof in strict scientific sense [32]; as shown in **Fig. I (b)**, there still is a possibility of unexpected "Compound B" even when many necessary conditions that are consistent with expected "Compound A" are obtained.

Known: Methods for product identification in an organic chemical sense.

Unknown: Sufficient conditions for product identification in a strict scientific sense.

Interface, see "Junction" and "Hydroxyl radical".

Intermediate, see "Hydroxyl radical", "Identification", "Thermodynamics" and "Quantum efficiency".

Junction (See also "Band structure".)

In the early stage of studies on photocatalysis in the 1980's, a photocatalyst particle was often considered to be a "short-circuited photoelectrochemical cell" [33]. Titanium(IV) oxide (titania) particles loaded with platinum (Pt) were often employed as a photocatalyst working under deaerated conditions, the same as in ordinary photoelectrochemical measurements; titania and Pt work as an anode and a cathode, respectively, which are short-circuited with each other. It had been assumed that photoexcited electrons (e^-) in titania migrate to Pt through a junction (border) between titania and Pt. This junction had been discussed and concluded to be an ohmic one, not a Schottky one, considering the possible n-type character of titania electrodes prepared by heat treatment at a high temperature under vacuum or hydrogen atmosphere (**Fig. J (a) and (b)**). There must be such a contact between titania and Pt. Then does e^- actually migrate from titania and Pt and reduce protons to liberate hydrogen in photocatalytic reaction? At present, we have no technique to directly observe such migration through the junction and to check liberated whether hydrogen contains electrons originating from titania. As indirect evidence, i.e., a

supporting fact, Nakabayashi et al. reported that the observed isotope distribution in hydrogen liberated by a photocatalytic reaction with platinumized titania suspended in a mixture of water and heavy water (D_2O) was consistent with the ratio calculated on the basis of the assumption of hydrogen generation at the Pt surface, not on the titania surface [34]. Combining this with the fact that electrons in titania, not in Pt, are excited by photoirradiation, migration of e^- from titania to Pt has been elucidated. Similarly, small Pt deposits may enhance visible light-induced photocatalytic reaction of tungsten(VI) oxide (WO_3) by catalyzing multi-electron reduction of oxygen (O_2) on their surfaces [35]. In this case, the CB bottom of WO_3 is reported to be more anodic than the standard electrode potential of $O_2/O_2^{\cdot-}$ and thereby one-electron reduction of O_2 by e^- in WO_3 is thermodynamically impossible (See "Gibbs energy"). The results showing enhanced photocatalytic activity of WO_3 suggest the migration of e^- in WO_3 to Pt and reduction of O_2 to hydrogen peroxide or water in multi-electron processes, though no direct evidence has been obtained and there has been no discussion on the junction between Pt and WO_3 .

It had also been believed that there should be a Schottky junction at an n-type semiconductor (n-SC)–electrolyte solution interface; a more cathodic position of a Fermi level of n-SC's results in transfer of electrons in the donor levels of n-SC to the electrolyte, and a depletion (space charge) layer appears (**Fig. J (c) and (d)**). This is the reason why n-SC electrodes show rectifying properties, i.e., negligible dark anodic current even under anodically polarized conditions due to the so-called "Schottky barrier" inhibiting electron injection from an electrolyte to an n-SC electrode in the dark and under photoirradiation (**Fig. J (e) and (f)**); electron transfer occurs from an n-SC electrode to an electrolyte under cathodic polarization since no barrier exists for such electron flow, while under photoirradiation and anodic polarization positive holes (h^+) can oxidize redox species in the electrolyte and photoexcited electrons (e^-) flow as an anodic current [36]. The thickness of the depletion layer, governing slope of the electric field, depends on the concentration of donors (impurities). For particles of titania that are not treated for crystalline defect (donor) introduction, the donor concentration seems to be low, and the depletion layer thickness might be larger than the particle size, resulting in a small

potential slope in the particles.

Known: Electronic structure of semiconductor–metal and solution interface in electrode systems.

Unknown: Actual contact of particle–solution interface and electron (positive hole) transfer through this junction.

Kinetics, see "First-order kinetics" and "Langmuir–Hinshelwood mechanism".

Kubelka–Munk function (See also "Optical band gap", "Quantum efficiency" and "Wavelength dependence".)

It is clear that photoabsorption is one of the most significant steps in photocatalysis and estimation of the number (or flux (= rate)) of absorbed photons is an important fundamental experiment, considering the first law of photochemistry [37], i.e., light must be absorbed by a chemical substance in order for a photochemical reaction to take place. However, precise measurements of a photoabsorption spectrum of solid materials are rather difficult as described below.

In the literature on photocatalysis, a photoabsorption spectrum, a plot of the extent of absorption as a function of wavelength, has been shown using a unit of absorbance or Kubelka–Munk function. The former, absorbance, is defined as $\log(I_0/I)$, where I_0 and I are intensities of incident and transmitted light, respectively. The meaning of this definition is that incident light is absorbed by hypothetical thin layers of a medium at a constant fraction to result in logarithmic decay of intensity (**Fig. K (a)**). When photoabsorption is measured in a reflection mode, I can be an intensity of reflection, but, different from the measurement in a transmission mode, it is impossible to measure intensity of incident light by removing a sample because of the lack of reflection (**Fig. K (b)**), and thereby an integration sphere, the inner wall of which is covered with a "standard reflection material" such as barium sulfate, should be used based on the assumption that a such standard material reflects all incident light, i.e., 100% reflection. Even if this reflection problem is solved, measured optical density cannot be

absorbance, since absorbance can be defined for the case where extinction of light intensity is assumed to be induced only by photoabsorption, not by scattering [38]. When such an effect of light scattering is neglected, absorbance is proportional to the concentration of a given material dispersed in a homogeneous medium but not to the number of photons absorbed by a solid sample. This is easily understood by the fact that absorbance 1 and 2 correspond to 90 and 99% absorption of incident light. In order to calculate the extent of photoabsorption of a solid sample, it is necessary to measure absorption, I/I_0 , not absorbance.

On the other hand, the Kubelka–Munk (K–M) function is defined as

$$\frac{(1 - R_d^2)}{2R_d} = \frac{\alpha}{s}, \quad (\text{eq. K})$$

where R_d , α and s are diffuse reflectance ($= I/I_0$), absorption coefficient and scattering coefficient, respectively. For samples diluted with a medium of less photoabsorption, K–M function can be a measure of sample concentration. The K–M function is often recognized, though this requires assumptions, to be proportional to the absorption coefficient (See "Optical band gap"). Based on these considerations, both absorbance and Kubelka–Munk function show the extent of the ability of a substance for logarithmic decay of incident light. Therefore, concentration of a compound included in a solution or a solid medium can be evaluated by measuring absorbance or K–M function, respectively, of the corresponding peak (shoulder) in an absorption spectrum as shown in **Fig. K (c)**. Thus, both absorbance and K–M function cannot be a measure of absorbed light intensity.

Known: Method for conversion of data of reflectance to Kubelka–Munk function (K–M function).

Unknown: Meaning of K–M function as concentration of a target compound mixed with a matrix.

Langmuir–Hinshelwood mechanism

The term "Langmuir–Hinshelwood mechanism" has often been used in discussion of the mechanism of photocatalytic reaction in suspension systems, but, as far as the author knows, there has been no definition given for the Langmuir–Hinshelwood (L–H) mechanism in photocatalytic reactions. In most cases, authors have claimed that a photocatalytic reaction proceeds via the L-H mechanism when a linear reciprocal relation is observed between the reaction rate and the concentration of reaction substrate in a solution. These experimental results seem to be consistent with the following equation:

$$r = \frac{kSKC}{KC + 1}, \quad (\text{eq. L})$$

where r , k , K , S and C are rate of the reaction, rate constant of the reaction of the surface-adsorbed substrate with e^- (h^+), adsorption equilibrium constant, limiting amount of surface adsorption and concentration of substrate in the bulk at equilibrium, respectively [39], when the substrate is adsorbed by a photocatalyst obeying a Langmuir isotherm and the adsorption equilibrium is maintained during the photocatalytic reaction, i.e., the rate of adsorption is faster than that of the reaction with electrons or holes (See "First-order kinetics"). Such a situation is often called "light-intensity limited" conditions, i.e., photoabsorption is the rate-determining step (See "Rate-determining step"). Several methods for linearization of **eq. L** have been reported, but two kinds of plots are often employed for analysis. As shown in **Fig. L**, the most popular one is a plot of reciprocal rate against reciprocal concentration, and another one is a plot of ratio of concentration to rate against concentration. Both plots give ideally the same values of parameters, kS and K , while the former plot reflects mainly lower-concentration data with probable relatively large experimental error.

The original meaning of the term "Langmuir–Hinshelwood mechanism" in the field of catalysis is, to the author's knowledge, a reaction of two kinds of molecules proceeding on a surface in which both molecules are adsorbed at the same surface adsorption sites with the

surface reaction being the rate-determining step (in the original meaning of "rate-determining step"). Of course, the general rate equation for the L-H mechanism (not shown here) includes two sets of parameters for two kinds of molecules, and when one set of parameters is neglected, the equation is for a monomolecular reaction, similar to the photocatalytic reaction of a substrate adsorbed in Langmuirian fashion. However, at least in the field of catalysis, the term L-H mechanism is rarely used for such monomolecular surface reactions, since the L-H mechanism has been discussed for a bimolecular surface reaction by comparing with the Rideal-Eley mechanism, in which a surface-adsorbed molecule reacts with a molecule coming from the bulk (outside).

Even if the L-H mechanism is defined as the reaction of a surface-adsorbed substrate obeying a Langmuir isotherm governing the overall rate, the frequently reported experimental evidence, a reciprocal linear relation between concentration of the substrate in solution and rate of photocatalytic reaction, is not always proof of this mechanism. From the linear plot, two parameters are calculated [40]. One (often shown as " k ", not as " kS ") is a limiting rate of the reaction at the infinite concentration giving maximum adsorption, i.e., kS , and the other is the adsorption equilibrium constant, K . The former parameter is a product of rate constant and adsorption capacity of a photocatalyst and this may be a photocatalytic activity. The latter parameter shows the strength of adsorption and must be the same as that estimated from an adsorption isotherm measured in the dark [41]. If kinetically obtained K is different from that obtained in dark adsorption measurement, the L-H mechanism cannot be adopted. Therefore, dark adsorption measurement is always required. Finally, it should be noted also in this case that a linear relation fitting to a Langmuir-type adsorption isotherm [42] and similarity of adsorption equilibrium constants estimated using photocatalytic reaction rate and by dark adsorption experiments are only required conditions; the observed reaction rate is "consistent" with kinetics of a substrate undergoing Langmuir-type adsorption and does not exclude the possibility of other reaction kinetics.

Known: Method for double-reciprocal plotting of reaction rate and substrate concentration.

Unknown: Possibility of reaction mechanism not related to Langmuir-type isotherm of adsorption.

Mutual recombination

Recombination of a photoexcited electron (e^-) and a positive hole (h^+) occurs to some degree in photocatalysts, and this reduces quantum efficiency, i.e., efficiency of e^-h^+ used in chemical reaction(s), and overall photocatalytic reaction rate. Since recombination does not produce any chemicals, it is not easy to estimate the rate of recombination directly. One possible way for estimating recombination rate is to subtract the overall rate of chemical reaction by e^-h^+ from the rate of photoabsorption, but the obtained data cannot give any other information.

Kinetics of e^-h^+ recombination may depend on its fashion; if one electron is excited and this is recombined with h^+ , the recombination rate obeys the first-order rate law, while if multiple e^-h^+ appear at the same time within a photocatalyst particle, the rate obeys the second-order rate law. Actually, in a femtosecond pump-probe diffuse reflection spectroscopic analysis of titania samples, photoabsorption at 620 nm by trapped electrons showed second-order decay with a component of baseline as follows:

$$(\text{absorption}) = \alpha \left\{ \frac{[e_0]}{1 + k_r [e_0] \times t} + BL \right\}, \quad (\text{eq. M})$$

where α , $[e_0]$, k_r , t and BL are a constant, initial concentration of trapped electrons at time zero, second-order rate constant, time after pump pulse (at 310 nm) and baseline component, respectively [43]. A baseline component might correspond to electrons trapped in deep traps. Different from kinetic analysis based on the first-order rate law (See "First-order kinetics".), analysis based on second-order rate law requires absolute values of concentration ($[e_0]$ in **eq. M**) and photoabsorption coefficient (α in **eq. M**) of a target compound, but these cannot be determined experimentally, at least when the analyses are performed and calculation is performed

assuming α to be unity. An example of these kinetic analyses is shown in **Fig. M** for Degussa (Evonik) P25 [44]. Although the thus-obtained second-order rate was relative, it was observed that k_r 's of different titania samples in the form of powder are proportional to those in suspension systems, suggesting that k_r can be a measure of rate of recombination. However, it must be noted that such a second-order recombination process cannot be reproduced in an ordinary photoirradiation process in which lower light intensity induces single-electron photoexcitation and mutual recombination occurs obeying the first-order rate law [45].

Known: Behavior of recombination of e^- and h^+ depending on their density.

Unknown: Absolute rate constant of mutual recombination occurring during photocatalytic reaction under ordinary photoirradiation systems.

Nanostructure

There have been many reports on preparation of photocatalysts with nanometer-sized structures, e.g., nanoparticles, nanoplates, nanocubes, nanorods, nanotubes or nanowires, as well as their photocatalytic activities [46], and the number of such reports is still increasing. A possible reason for such an explosive increase in studies on nanostructured photocatalysts is popularization of low-priced pressure-tolerant Teflon bottles for hydrothermal reactions. By using this type of apparatus, a variety of inorganic compounds can be prepared and morphology can be changed depending on the reaction conditions. Scanning or transmission electron microscopic images of those nanostructured photocatalysts (even non-photocatalysts) are attractive and interesting. However, considering that we do not know what structural parameters of photocatalysts govern the photocatalytic activity and how they govern the photocatalytic activity, there seems to be no assured reason why nanostructured materials, rather than ordinary non-structured ones, should be employed.

Recently, decahedral-shaped anatase-titania particles (DAPs) have been prepared by controlled gas-phase reaction of titanium(IV) chloride and oxygen at 1473 K (**Fig. N**) [47]. The photocatalytic activity of DAPs was reported to be much higher than the photocatalytic activities

of commercial titania particles, e.g., Degussa (Evonik) P25, presumably due to relatively large specific surface area to adsorb a large amount of substrate(s) and high crystallinity, i.e., less crystalline defects to reduce e^-h^+ recombination. Then, how does the decahedral shape itself affect the photocatalytic activity?

In a recent study by the author's group, photocatalytic activities and physical and structural properties of 35 commercial titania powders were statistically analyzed to find the predominant property (properties) determining the activity of a given reaction system [48]: standardized photocatalytic activities for five kinds of reactions were fairly well reproduced by a linear combination of six kinds of physical and structural properties of photocatalysts, i.e., specific surface area, density of crystalline defects, primary particle size, secondary particle size and existence of anatase and rutile phases. It was suggested that high levels of photocatalytic activity of DAPs could not be reproduced by the correlation equations derived in the above-mentioned multivariable analysis [49], i.e., another property, such as "shape" may affect the photocatalytic activities.

Known: Wide variety of photocatalysts with characteristic morphology can be obtained by changing reaction conditions, especially under hydrothermal conditions.

Unknown: How the nano- or other size-range structures themselves affect photocatalytic activities.

Necessary condition, see "First-order kinetics", "Gibbs energy" and "Identification".

Optical band gap (See also "Band structure" and "Kubelka-Munk function".)

Since the ability of a photocatalyst is essentially governed by its band position, i.e., conduction-band (CB) bottom and valence-band (VB) top, as described in "Band structure", estimation of the potential of the CB bottom and VB top is important to predict the possibility for driving a photocatalytic reaction from the thermodynamic point of view. A general way for such estimation involves measurements of flat-band potential (See "Band structure" and

"Junction".) and band gap corresponding to the potential of the CB bottom and difference in potential between the CB bottom and VB top, respectively, enabling estimation of the potential of the VB top from them. Optical band gap can be estimated using the following equation.

$$\alpha \propto \frac{(h\nu - E_g)^n}{h\nu} \quad \text{or} \quad (\alpha\nu)^{\frac{1}{n}} \propto h\nu - E_g, \quad (\text{eq. O})$$

where α , h , ν , E_g and n are absorption coefficient, Planck constant, oscillation frequency, optical band gap and constant relating to a mode of transition. The constant n is $\frac{1}{2}$, $\frac{3}{2}$ or 2 for allowed direct transition, forbidden direct transition or indirect transition, respectively, but the second forbidden direct transition has often been neglected. It is described in textbooks of semiconductor physics (or electronics) that by checking linearity of plots of $(\alpha\nu)^{\frac{1}{n}}$ against $h\nu$ using n as 2 or $\frac{1}{2}$, the mode of transition of a given crystal and optical band gap are estimated, the latter of which is estimated by an x-intercept of the straight line [50].

Figure O shows an example of the above-mentioned analysis for well-crystallized rutile titania (TIO-3) calcined at 1173 K in air for 2 h [51]. Kubelka–Munk function (KM) is used, as usual, instead of α in **eq. O**, assuming that coefficient of scattering, s (See "Kubelka-Munk function".), is constant throughout a wavelength range for measurement. Straight lines could be drawn, as shown in **Fig. O (a)**, based on the assumption of indirect and direct allowed transitions, and their x-intercepts, 3.00 and 3.14 eV corresponding to band gaps for indirect and direct transition, respectively, are obtained. Then, which is better, indirect and direct transition? An approximate range of the straight part of these plots was 0.14 eV and 0.20 eV for indirect and direct transitions, respectively, suggesting "direct transition" for this rutile titania sample [52]. However, can we conclude that the transition of the rutile sample is "direct" and the band gap is 3.14 eV? At least for the author, the answer is "no". The range of the linear part of plots in **Fig. O (a)** seems to have a large extent of facultativity, and there seem to be no rules to discriminate a mode of transition on the basis of range of the linear part. An interesting point is that it is also possible to estimate band gaps from absorption spectra. **Figure O (b)** shows such

examples; straight lines can also be drawn for plots of %absorption and K–M function to give x-intercepts of 2.91 eV and 3.07 eV, respectively. Again, there are no fixed ways to find reliable and reasonable data on band-gap energy [53].

Another problem in the band-gap energy estimation is influence of impurity or surface electronic states on absorption spectra; spectral curves at the absorption edge region may be markedly modified to give smaller band-gap energy, and it is very difficult to extract a part of the absorption due to band-gap excitation from that by impurities (dopants) or surface states. Therefore, especially for doped samples, discrimination of narrowing of the band gap and overlapping of absorption by bulk or surface modification from shift of absorption to longer wavelengths is difficult (See "Doping" and "Visible light-induced photocatalysis").

Known: A method for band-gap energy estimation by plotting data using the Kubelka–Munk function of a photocatalyst.

Unknown: A method for judgment of the mode of transition and for exclusion of the influence of absorption by impurities or surface electronic states.

Organic synthesis, see "Identification".

Particle size

Particle size of a photocatalyst is often evaluated by Scherrer's equation using data of powder X-ray diffraction pattern (XRD). Scherrer's equation is

$$L = \frac{K\lambda}{\beta \cos \theta}, \quad (\text{eq. P})$$

where L , K , λ , β , and θ are size of particles in the direction vertical to the corresponding lattice plane, a constant [54], wavelength of X-ray, corrected full width at half maximum (FWHM) of the XRD peak, and angle of diffraction, respectively. Since K has been introduced in the derivation of this equation [16] to be 0.891, K has its effective digits. The effective digits of the

resulting size of particle L should be one if "0.9" is used for K . In order to show the size L with three-digit accuracy, a value of "0.891" should be used. Another point to be noted is the correction of FWHM. Two kinds of correction are required. One is correction for broadening due to $K_{\alpha 2}$ radiation, and the other is for broadening due to the optical path in the diffractometer. Generally speaking, the former and the latter corrections are made by assuming a radiation intensity ratio of $K_{\alpha 1}$ and $K_{\alpha 2}$ and by using FWHM of a standard large crystalline sample. There are at least three ways for the latter correction, but there seems to have been no discussion on the best way. The simplest way, subtraction of FWHM of the standard, has often been employed. To the author's knowledge, both corrections appreciably affect the size of particles; a large error is expected without such corrections. Therefore, when the size of particles is demonstrated, the methods used for FWHM corrections should be described [55].

As described above, the size of particles in the direction vertical to the corresponding lattice plane can be estimated using Scherrer's equation. In comparison with the data obtained in another way, e.g., transmission or scanning electron microscopy, difference due to this may be observed. Furthermore, broadening of FWHM of XRD peaks is also induced by distortion of the crystalline lattice. The Williamson-Hall equation includes this, as well as the effect of particle size [56]. In other words, Scherrer's equation neglects the effect of crystal lattice distortion. For samples that are expected to have a large degree of distortion, analyses using the Williamson-Hall equation should be carried out.

Then, can we know particle size from the above-mentioned analysis? A problem is still hidden. Distribution of size and its effect on evaluation of average size should be considered. **Figure P** shows hypothetical fractions of spherical particles of 1, 10, 25 and 100 nm in diameter calculated on the basis of number, surface area and volume (weight). Even if number-based fractions are all the same, 25%, for the four kinds of particles, surface area-based and volume-based fractions are 93% and 98%, respectively. Therefore the average size of particles calculated on the basis of these fractions is 34, 94 or 98 nm when number, surface area or volume fraction is employed [57] (A notable point is that the difference in average size between the mode

of surface area-based and volume-based ones is smaller than 5%). When particle size is measured by electron microscopic images of SEM or TEM, particles are categorized by size and counted (making a histogram) from images in ordinary procedures [58]. The average size may be a number-based one unless volume fraction is considered.

Then, what is the mode of average size of particles, with wide distribution of size, obtained by Scherrer's equation; average in number, surface area or volume based one. There seems to be no clear answer. Assuming a spherical shape of titania particles with density of 4 g cm^{-3} , a product of specific surface in the unit of $\text{m}^2 \text{ g}^{-1}$ and diameter in the unit of nm is calculated to be 1500 [59]. In the author's experience, many commercial titania samples obey this correlation when (primary) particle size is measured using Scherrer's equation, suggesting that average particle size obtained using Scherrer's equation is similar to the surface area-based or volume-based average.

Another topic related to particle size of a photocatalyst is "quantum-size effect". This frequently used term means that when the size (radius) of solid particles becomes smaller than their Bohr radius, the bottom of the conduction band and the top of the valence band shift in negative (high electronic energy) and positive (low electronic energy) directions, respectively, resulting in expansion of the band gap. The Bohr radius for anatase particles and that for rutile particles have been estimated to be 2.5 and 0.3 nm, respectively [60]. Preparation of crystalline titania particles of such small size seems to be difficult, and titania particles claimed in papers to show a quantum-size effect might be larger than these sizes. A blue (shorter wavelength) shift, if observed, of the absorption edge of those samples might be due to the amorphous part of titania, not to the quantum-size effect. At least for a titania photocatalyst, use of quantum-size effect for interpreting the results seems inappropriate.

Known: Several methods to determine particle size.

Unknown: Mode of average size, number, surface-area or volume (or others)-based one.

P25, see "Synergetic effect".

Photocatalysis, see "Thermodynamics" and "Band structure".

Positive hole, see "Hydroxyl radical".

Quantum efficiency (See also "Mutual recombination" and "Wavelength dependence".)

The term "quantum efficiency" or "quantum yield" was originally defined as a ratio of number of products (or consumed starting material) to that of absorbed photons in photoreaction in homogeneous phase, i.e., in solutions or gas phase, assuming that one photon induces reaction or change in one molecule (second law of photochemistry) [61] since a multi-photon process and subsequent multi-electron transfer can be neglected in ordinary photoirradiation conditions with relatively low photon flux. Confusion might arise when this concept is applied to photocatalysis, in which a multi-photon process and at the same time radical chain reaction may be included, especially in reaction in the presence of oxygen.

For example, photocatalytic silver metal deposition accompanied by molecular oxygen (O₂) liberation proceeds with the following stoichiometry [62]:

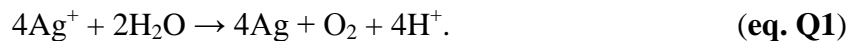

For the determination of quantum efficiency, it is necessary to make an assumption on how many photons are required for the reaction. One of the possible and the most frequently employed assumptions is that four photons are required for liberation of one oxygen molecule, four silver metal atoms, or four protons, and when the O₂ yield is used, the quantum efficiency is calculated to be

$$\frac{4n(\text{O}_2)}{n(\text{photon})}, \quad (\text{eq. Q2})$$

where n is the number of molecules or photons [63]. Thus, for the calculation of quantum efficiency of heterogeneous photocatalytic reactions, it is reasonable to consider the efficiency of utilization of electrons-positive holes assuming that an electron and positive hole pair is produced

by absorption of a photon. However, since neither a photoexcited electron nor a positive hole appears in stoichiometry, the above-mentioned consideration may not always be straightforward. For example, acetic acid dissolved in air-saturated water is decomposed into carbon dioxide by an appropriate suspended photocatalyst with the following proposed stoichiometry:

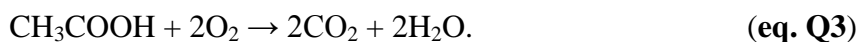

How many photons are required for this reaction? Assuming that only O_2 is reduced by photoexcited electrons in this reaction and that reduction of an O_2 molecule requires four electrons, this reaction is an eight-electron process. However, since the photocatalytic reaction of acetic acid may include a radical chain mechanism or at least addition of O_2 to intermediate radicals, an acetic acid molecule could be decomposed by less than 8 electrons. It is impossible to calculate intrinsic quantum efficiency, i.e., efficiency of utilization of electron-positive hole pairs, only from the product yield. Therefore, quantum efficiency is reported with the description that a given reaction is assumed to proceed through a proposed multi-electron process (e.g., 8 for acetic acid decomposition or 4 for carbon dioxide liberation in **eq. Q3**).

Another problem for determination of quantum efficiency is the difficulty in determining the number of absorbed photons. Unlike measurement for homogeneous solutions, solid materials scatter incident photons to reduce the light intensity arriving at a detector in a spectrophotometer. In the wavelength region in which only some of the photons are absorbed, i.e., around the band-edge wavelength, it is difficult to measure the photoabsorption efficiency (This problem is discussed in "Kubelka–Munk function"). Therefore, apparent quantum efficiency (photonic efficiency) has often been used instead of quantum efficiency, and apparent quantum efficiency is calculated by the number of incident photons rather than the number of photons used for quantum efficiency calculation. Since quantum efficiency is defined as efficiency of electron-positive hole utilization, apparent quantum efficiency is a product of efficiencies of photoabsorption and electron-positive hole utilization as shown in **Fig. Q (a)**. Of course, both quantum efficiency and apparent quantum efficiency depend on the irradiation

wavelength and sometimes on the irradiation intensity (See **Fig. Q (b)**), and thereby the data should be shown with wavelength and preferably with intensity. In this sense, such measurement must be performed by monochromatic irradiation; irradiation with sharp-cut optical filters is inappropriate (See "Wavelength dependence").

Known: Practical method for determination of apparent quantum efficiency defined as the ratio of number of electrons or holes used in photocatalytic reaction to number of photons incident on a reaction system, assuming the number of electrons or holes required to produce one molecule of product(s).

Unknown: Intrinsic quantum efficiency, i.e., the fraction of electron-positive hole pairs that escape from their mutual recombination.

Quantum-size effect, see "Particle size".

Rate-determining step (See also "First-order kinetics".)

Assuming that a certain reaction proceeds through a series of steps without any branching reactions, the rate must be the same as the rate of the slowest step, the rate-determining step, i.e., the overall activation energy is that of the rate-determining step (**Fig. R (a)**). This original definition cannot be directly applied to photocatalysis. A plausible reason is that reactions by photoexcited electrons and positive holes occur in parallel, not in series (**Fig. R (b)**). Considering the requirement of photocatalysis for the same numbers of electrons and positive holes to be used, it seems possible to compare the rates of electron and positive-hole reactions. However, it seems that overall reaction rate must also be influenced by the rate of recombination of e^-h^+ included in the process. In ordinary photochemistry in homogeneous phase, steady (stationary)-state approximation is used to analyze kinetics, assuming a forward reaction to give products and a backward reaction, i.e., deexcitation. In such analyses, there may not be a rate-determining step.

On the other hand, it seems reasonable to consider that, under limited reaction conditions,

non-chemical processes, i.e., physical processes, may govern the overall rate of photocatalytic reactions. Two possible representative examples are as follows. In the case in which a surface reaction of adsorbed substrates with photoexcited electrons and positive holes is much faster than adsorption from a solution or gas phase, the reaction rate should be the same as that of diffusion of the substrate, i.e., a diffusion-controlled process (Assuming a very thin diffusion layer on the surface of a photocatalyst, the rate of diffusion may be proportional to surface area of the photocatalyst.). Another example is a light intensity-controlled process. If surface reactions by photoexcited electrons and positive holes proceed slower than the adsorption of substrates, the surface concentration is always in equilibrium, and the overall rate should be same as the rate of surface reaction, which is ideally proportional to the light intensity, a "light-intensity limited" process.

Known: Inappropriateness of discussion on rates of reduction by photoexcited electrons and oxidation by positive holes.

Unknown: Intrinsic rate of recombination governing the overall reaction rate.

Recombination, see "Mutual recombination".

Redox mediator, see "Z-scheme photocatalysis".

Rutile, see "Synergetic effect".

Scherrer equation, see "Particle size".

Second-order kinetics, see "Mutual recombination".

Semiconductor, see "Band structure", "Energy conversion", "Junction", "Optical band gap" and "Thermodynamics".

Solar radiation, see "Ultraviolet light in solar radiation".

Stoichiometry, see "Quantum efficiency", "Visible light-induced photocatalysis" and "Yield".

Synergetic effect

The term "synergetic effect" in photocatalysis could be defined as follows: when more

than two kinds of photocatalysts are used as a mixture, the overall photocatalytic activity exceeds the sum of activities of each photocatalyst. When a certain component alone is not a photocatalyst, and its mixture with a photocatalyst shows improved activity, that component should be called "co-catalyst" or "enhancer", and the improvement cannot be attributed to a synergetic effect. One of the representative discussions on the synergetic effect is for anatase-rutile mixed crystalline photocatalysts, such as Degussa P25. The co-presence of anatase and rutile crystallites induces a high level of photocatalytic activity; transfer of photoexcited electrons and positive holes between interconnecting anatase and rutile particles may enhance charge separation and hence improve the efficiency of utilization of electron-hole pairs. However, as far as the author knows, there have been no reports showing direct evidence of such inter-particle charge migrations and the expected lower level of activity of pure anatase or rutile particles alone. In a scientific sense, isolation of anatase and rutile crystallites from P25 is necessary to determine the crystalline composition and to check the synergetic effect of anatase and rutile, since, as shown in **Fig. S**, a synergetic effect can be proved only by showing better photocatalytic activity for a mixture of components A and B than the activities of components A and B alone. Ohno et al. reported that in a certain photocatalytic system, commercial anatase and rutile powders exhibit a synergetic effect. The author thinks that a synergetic effect has not yet been proved for P25, and the effect seems to be speculation. This is natural considering that each component, anatase and rutile, in P25 had not been isolated before the work of isolation of anatase by the author's group [64]. Even if all of the components are isolated from the mixture, how can we show a synergetic effect? Taking into consideration the fact that a photocatalytic reaction proceeds by photoabsorption of the photocatalysts and the fact that total number of absorbed photons is not directly proportional to mass (volume) of the photocatalyst, a control experiment using each component should be carried out with adjustment to make the flux of absorbed photons the same as that for the mixture. However, discussion is still needed to establish a method to clarify the synergetic effect in photocatalysis.

Known: How to confirm a synergetic effect when two components are obtained in pure forms.

Unknown: How to confirm a synergetic effect when two components are originally in a mixture and each pure component cannot be obtained.

Temperature dependence, see "Thermodynamics".

Thermodynamics

Although there are various definitions for the term "photocatalysis", in order to save space, "photocatalysis" or "photocatalytic reaction" can be defined as a chemical reaction induced by photoabsorption of a solid material, or "photocatalyst", which remains unchanged during the reaction. In other words, the solid acts catalytically (without change) under light and this explanation may be consistent with most definitions. "Photocatalysis" is the conceptual name for photocatalytic reactions. From this understanding, basic data can be obtained by measuring the consumption of the starting materials and/or reaction products initiated by photoirradiation and then examining whether the photocatalyst or its properties have been modified during the reaction. This seems to be a relatively easy procedure. However, various problems are, in fact, encountered when trying to prove a given phenomenon as being photocatalytic (See "Wavelength dependence" and "Identification").

The most significant difference, as far as the author knows, between photocatalysis and catalysis lies in their thermodynamics. In a general definition, a catalyst reduces activation energy of chemical reaction by changing the intermediate states and thereby accelerates the reaction which proceeds spontaneously with negative Gibbs energy change, i.e., catalysis is limited to thermodynamically possible reactions ($\Delta G < 0$, e.g., oxidative decomposition of organic compounds under aerated conditions). On the other hand, it is well known that photocatalysis can drive energy-storing reactions ($\Delta G > 0$), e.g., splitting water into hydrogen and oxygen, as has been reported. In this sense, "photocatalysis" must be recognized as a concept completely different from that of "catalysis". Actually, apparent activation energy of photocatalysis estimated by an Arrhenius plot has been reported to be very small compared with

that of catalytic reactions [65].

The principle of photocatalysis is often explained with a figure like **Fig. T**: a schematic representation of the electronic structures of semiconducting materials, a band model; an electron in an electron-filled valence band (VB) is excited by photoirradiation to a vacant conduction band (CB), which is separated by a forbidden band, a band gap, from the VB, leaving a positive hole in the VB (See "Band structure" and "Gibbs energy"). These electrons and positive holes drive reduction and oxidation, respectively, of compounds adsorbed on the surface of a photocatalyst. Such an interpretation accounts for the photocatalytic reactions of semiconducting and insulating materials absorbing photons by the bulk of materials. In the definition given above, however, no such limitation based on the electronic structure of a photocatalyst is included. For example, isolated chemical species not having the above-mentioned band structure on or in a solid can be a photocatalyst (**Fig. T**), and even when a bulk material is used, the photoabsorption and resultant photocatalytic reaction may proceed at a localized site when, for example, photocatalysts are photoirradiated at a wavelength near the band gap. Therefore, the interpretation using a band model is not always adequate for understanding photocatalysis. In this sense, the term "heterogeneous photocatalytic reaction (photocatalysis)" seems better than "semiconductor photocatalytic reaction" based on the electronic band structure.

Known: Thermodynamic explanation using a band model of semiconducting materials.

Unknown: General description of thermodynamics of photocatalysis defined for materials including molecular or highly dispersed compounds.

Time-resolved spectroscopy, see "Mutual recombination"

Turnover number, see "Yield"

Ultraviolet—visible spectroscopy, see "Optical density".

Ultraviolet light in solar radiation (See also "Energy conversion" and "Visible-light induced photocatalysis".)

Since titania, a representative potential photocatalyst, can absorb only ultraviolet light, at a wavelength shorter than ca. 390 nm for anatase titania (See "Optical band gap".), many studies to extend this absorption range to the visible light region have been performed in order to utilize solar radiation as an energy source for photocatalysis. For the practical application of photocatalysis using solar radiation and indoor light, such an extension of wavelength range is very important. In the introductory parts of reports on related subjects, the content of ultraviolet light in solar radiation is often stated to be ca. 3–5% without showing a reference, presumably due to repeated re-quotations. The author could not find the original paper showing calculation of this content.

Using data on solar radiation at the ground surface in the temperate zone (AM1.5; **Fig. U**) [66] reported by the American Society for Testing and Materials (ASTM, <http://www.astm.org/> ASTM), accumulated intensity of ultraviolet light below wavelengths of 380, 390, 400 and 410 nm corresponds to 3.24, 3.87, 4.63 and 5.81%, respectively, of total energy of light of wavelength up to 4000 nm (1001.0 W m^{-2}) [67]. Considering that the boundary wavelength of ultraviolet light and visible light is ambiguous (since the term "visible" means that one can see the light and the boundary is perceived to be different among individuals), the above-mentioned content, 3—5% (or 3—6%), seems reasonable. The first paper, if it exists, describing this range of ultraviolet light content might have shown a similarly calculated result, and authors of subsequent papers might have referred to this content without citation.

It should be noted that the calculation has been made on the basis of energy of light, not on the basis of number of photons. In discussing energy conversion efficiency (See "Energy conversion".), e.g., for solar cells, in which efficiency of conversion of solar energy is significant, content of light of a certain wavelength region should be discussed on the basis of energy. However, photocatalytic reactions except for energy conversion systems of, e.g., photosplitting of water into hydrogen and oxygen, do not convert energy. Thus, the energy conversion efficiency cannot be discussed and, instead, quantum efficiency (described below) becomes significant. Under such conditions, the content of light of a certain wavelength region should be calculated or

measured on the basis of photon numbers. Energy of a photon in the ultraviolet light region is larger than that in the visible light and infrared light regions and thereby the content calculated on the basis of number of photons must be much smaller than 3 —5%.

Known: Content of ultraviolet light in solar radiation based on energy.

Unknown: Content of ultraviolet light in solar radiation based on photon number.

Visible light-induced photocatalysis (See also "Band structure" and "Doping".)

Since solar radiation includes light of wavelengths from 280 to 4000 nm, use of photocatalysts that absorb light in visible and near-infrared regions is desired. However, light of longer wavelength has smaller energy, leading to a decrease in potential for redox reactions, and thereby reactions driven by visible-light irradiation are limited to those satisfying the thermodynamic and kinetic requirements. Many studies have been performed to design and develop photocatalysts that work under visible-light irradiation. Strategies that have usually been employed in such studies are modification (doping) of titania to give visible-light absorption or use of colored mixed metal oxide and nitride. Although it is expected that such doping of crystalline and use of mixed metal oxide/nitride may induce formation of lattice defects, which enhance electron-hole recombination, resulting in lower photocatalytic activity (See "Doping".), discussion of the strategies is not a purpose of this section. Some problems in studies on visible light-photocatalytic activity are discussed here.

First, the boundary wavelength between ultraviolet light and visible light should be defined. The meaning of the term "visible light" is light that can be seen, and the limiting wavelength differs among individuals. Many studies demonstrating that visible light induced, as expected, a photocatalytic reaction used the condition of photoirradiation through an optical cut-off filter, L-42 or its equivalent, and the irradiation wavelength under such conditions used to be described as "> 420 nm". However, this is inadequate because this filter transmits light of wavelength > ca. 390 nm. Actually, in the author's experience, appreciable photocatalytic activity of not only rutile but also anatase titania photocatalysts could be observed by irradiation

through the filter. When this optical filter is used for irradiation, at least comparison of the photocatalytic activity with that of a representative titania photocatalyst, such as P25 (Degussa (Evonik)) or ST-01 (Ishihara Sangyo), is necessary. Otherwise, optical cut-off filters of longer transmission limits should be used. One of the possible and smart ways is to define "visible light" as light that negligibly drives photocatalytic reaction by titania and to use an appropriate optical filter to realize this, considering the history of studies on photocatalysis.

Showing that a certain reaction proceeds under the above-mentioned visible-light irradiation conditions is not proof of visible light-induced photocatalytic activity unless an appropriate compound is used for the photocatalytic activity test. Dyes have relatively large photoabsorption (extinction) coefficients (This is the reason why they are used as dyes, i.e., coloring agents.) and therefore measurements of their concentrations in solutions are easy even if the concentrations are very low. However, the fact that dyes absorb visible light indicates that a photoreaction might be induced by visible-light photoabsorption (dye sensitization) as well as by photoabsorption of a photocatalyst. Although this problem had been pointed out earlier [68], there have been no clear experimental results showing the self-photodecomposition of dyes, presumably due to the difficulty in determining the mechanism of this photoreaction. Actually, determination of the extent to which incident photons are absorbed by a dye and photocatalyst is difficult. A paper has been published to show that methylene blue (MB), the most frequently employed dye, as well as, presumably, other kinds of organic dyes, is inappropriate as a model compound, particularly for testing visible light-induced photocatalytic activity [19,69]. There are at least three reasons for its inappropriateness. One is that the dye molecules absorb photons, especially in the visible light range, and thus-photoexcited electrons may be injected into photocatalyst particles as has been suggested by similarity of the action spectrum similar to the photoabsorption spectrum of the dye [70,71] (**Fig. V**). Another reason is that the absolute molar amount of dye contained in the reaction system can be much smaller than that of a solid photocatalyst. The concentration of dye in the solution should be relatively low since the absorption coefficient is large, as described in the first part of this section (See "Yield"). These

two facts are closely related to the problem of how we can prove a given reaction to be "photocatalytic", as discussed in "Thermodynamics" in this review. The third reason is that the mechanism of dye degradation is so complicated that efficiency of the photocatalytic reaction, e.g., quantum efficiency, cannot be measured. Measuring the consumption (decrease) of a dye during photoirradiation requires only a spectrophotometer, but the use of dyes as model compounds is inappropriate, and if dyes are used, care must be taken in the analysis of experimental results.

Then, what experimental results are needed to show that a given photocatalyst can drive the photocatalytic reaction under the conditions of visible light irradiation? In the author's experience, it is preferable to show an action spectrum, not "pseudo" action spectrum, that resembles a photoabsorption (diffuse reflectance) spectrum (See "Wavelength dependence"). When an action spectrum is measured, any reaction can be employed as a model reaction, but it is preferable to use a reaction for which the stoichiometry has been clarified. Without showing similarity of action and photoabsorption spectra, it is rather complicated to prove the reaction is a photocatalytic one under the conditions of visible light irradiation.

Known: Strategy to prepare visible light-sensitive materials.

Unknown (partly): How to prove a given reaction to be visible light-photocatalytic one.

Wavelength dependence (See also, "Optical density" and "Quantum efficiency".)

Since photocatalytic reaction is induced by photoabsorption as a general understanding, something, a photocatalyst, must absorb light to drive the photocatalytic reaction. Therefore, photocatalytic activity depends strongly on the wavelength of incident light, and showing resemblance of an action spectrum [72], wavelength dependence of photocatalytic activity, with an absorption spectrum of a photocatalyst candidate is essential to prove photocatalysis (assuming constant, wavelength-independent, true quantum efficiency, as discussed in "Quantum efficiency").

An action spectrum is a plot of apparent quantum efficiency, not (true) quantum

efficiency, against wavelength of light used for apparent quantum efficiency measurement (See **Fig. Q (a)**). Therefore, it is clear that monochromatic light irradiation is required to record an action spectrum. A grating-type monochromator with a light source such as a xenon arc lamp is usually used. Interference-type optical filters, transmitting at only a certain wavelength region, can also be used for monochromatic irradiation, though wavelengths of possible irradiation are limited. Because of possible dependence of apparent quantum efficiency on light intensity [73], it is preferable to adjust the light intensity at each wavelength [74]. Wavelength-selective irradiation can be carried out using optical filters that transmit light of wavelength longer than a certain limit, i.e., "cut-off filters" or "sharp-cut filters". By using several cut-off filters with different cut-off wavelengths [75], a plot of apparent quantum efficiency against the cut-off wavelengths can be obtained, and this "pseudo action spectrum" seems like a "true" action spectrum obtained by the above-described monochromatic irradiation. However, those are completely different; a pseudo action spectrum is an integrated (from longer to shorter wavelengths) form of a "true" action spectrum if it is assumed that light intensity is constant in the whole range of irradiation, because of the difference in irradiation wavelength region (**Fig. W**). Consequently, the corresponding action spectrum should be estimated by differentiation of the pseudo action spectrum, i.e., a pseudo action spectrum is an integrated form, from a longer wavelength side, of corresponding action spectrum. A horizontal part in a pseudo action spectrum (**Fig. W**), if present, shows that apparent quantum efficiency at the wavelength is negligible even if an appreciable value is seen in the pseudo action spectrum.

Known: Importance of discussion with wavelength dependence, i.e., an action spectrum.

Unknown: (partly) Difference in an action spectrum and a pseudo action spectrum

X-ray diffraction, see "Crystallinity".

X-ray photoelectron spectroscopy

In the history of research on photocatalysis, use of X-ray photoelectron spectroscopy

(XPS) was not frequent before 2000. The reason may be that XPS gives information on valency of elements on and near the surface of photocatalysts, but the valency of elements in the bulk of photocatalysts can be elucidated by analyzing the crystal structure by X-ray diffraction (XRD) analysis. The exception was determination of valency of a loaded co-catalyst, such as platinum. In 2001, Asahi et al. reported doping of titania with typical-elements could induce photocatalytic activity under visible-light irradiation (See "Doping"), and the chance of using XPS has explosively increased, since analysis of valency of doped (or attached) element(s) is important to understand the structure of doped samples.

As often encountered misunderstanding in discussion of XPS data is that XPS peaks are assigned to chemical bonds, e.g., "The peak was assigned to Ti-N bond", although (chemical) shift of XPS peaks reflects only valency of atoms. This is presumably due to misunderstanding of the meaning of "binding energy" of an XP spectrum; binding energy in an XP spectrum shows energy required for removal of an electron from cores. As is shown in **Fig. X**, chemical shift in XPS appears due to the difference in electric charge in a given atom. When the oxidation state, i.e., valency, is changed for an atom, electrostatic attraction between an electron and atomic nuclei is modified; the more oxidized or reduced the atom is, the larger and smaller in the observed binding energy, respectively. In this sense, no influence of neighboring atoms is expected, or the effect of neighboring atoms appears as a change of charge in a target atom. If, for example, an XPS peak is observed at the same binding energy as that of titanium(III) nitride (TiN_3) in nitrogen-modified titania, it can be interpreted that titanium(III), like TiN_3 , may be included in the surface layer of the sample.

Known: Peak shift (chemical shift) in an XP spectrum shows valency of a given atom, but not a bond between atoms.

Unknown: Method for showing the existence of specific bonds (presumably by X-ray absorption spectroscopy).

Yield (See also "Identification" and "Quantum efficiency".)

Since photocatalytic reactions are "chemical" reactions, it is necessary to evaluate the extent of photocatalytic reactions in a "chemical" sense. When we can evaluate consumption of a substrate yield of a product, we should use them as absolute physical amounts with a unit of mole. An important point is that the rate of a chemical reaction can be defined only when the reaction stoichiometry is established, i.e., amounts of all of the starting materials and products should be measured. There are at least two reasons why absolute yield, not relative yield such as % yield, is required in discussion of photocatalytic reactions. One is that we have to consider the efficiency of utilization of e^-h^+ for redox reactions and the molar amount should be compared to that of incident and absorbed photons. Another reason is related to the definition of "photocatalysis". In a broad sense, a "photocatalyst" is a material that absorbs light and then induces chemical reaction without being modified or consumed during the reaction (See "Thermodynamics"). Therefore, the ratio of product(s) to photocatalyst in molar amount, "turnover number", must exceed unity. Many papers have claimed better (or the best) photocatalytic activity of newly prepared photocatalysts showing rate of disappearance of organic dyes in suspensions. Since photoabsorption coefficient of dyes is large (This is one of the reasons why they are used as dyes.), those photocatalytic reactions can be performed in highly diluted conditions; if the coefficient is $10^4 \text{ mol}^{-1} \text{ L cm}^{-1}$ and a 1-cm-path optical cell is used for photoabsorption measurement, concentration of a dye required to give absorbance of 1 is $10^{-4} \text{ mol L}^{-1}$, and absolute molar amount of the dye is $10 \text{ }\mu\text{mol}$ when a 100-mL aqueous solution is used for photocatalytic reaction. Assuming that 0.8 mg of a titania (molar weight = 79.87) photocatalyst is used and the dye is completely decomposed (**Fig. Y**), it is impossible to show turnover of the photocatalyst. In this sense, only a few reported results could show the turnover (catalytic action) of photocatalysts (The majority of papers showed only change in concentration (absorbance) based on the initial concentrations of dyes, and it is thereby impossible to check the turnover.).

Known: Importance of determination of absolute yield.

Unknown: (none)

Zeolites and mesoporous materials, see "Nanostructure".

Zero-order kinetics, see "First-order kinetics".

Z-scheme photocatalysis (See also "Gibbs energy" and "Thermodynamics".)

A system consisting of two photocatalytic reactions connected with a redox mediator has been called a "Z-scheme" reaction system and has been employed mainly for water splitting under visible-light irradiation [76,77]. The term "Z-scheme", originating from its shape when schematically shown [78], has been used to interpret the mechanism of photosynthesis by plants in which two chlorophyll molecules, P700 and P680 [79]. As **Fig. Z (a)** shows, a photocatalyst included in the part "R" reduces an oxidant ("objective reduction", e.g., hydrogen production from water) and oxidizes the redox mediator "M", while the part "O" oxidizes a reductant ("objective oxidation", e.g., oxygen production from water) and reduces M. Overall objective reduction and oxidation occur by two photoexcitation processes in which up-hill electron transport from the oxidant to the reductant can be driven [80], though maximum energy conversion efficiency, if the overall reaction is energy-storing, is halved compared with a system with a single photocatalyst inducing both objective reduction and oxidation. A significant merit of this Z-scheme system is to loosen the requirement of electronic structure of photocatalysts; a photocatalyst in part O is needed to drive an objective oxidation by h^+ , but not an objective reduction by e^- , and a photocatalyst in part R is needed to drive an objective reduction by e^- , but not an objective oxidation by h^+ , if an appropriate redox mediator, the standard electrode potential of which lies between a CB bottom of part O and a VB top of part R, is chosen [81]. As a result, photocatalysts of relatively narrow band gap, corresponding to photoabsorption of longer wavelength, can be used.

Then, can Z-scheme photocatalytic reactions solve all problems in the energy-storing photocatalytic reactions in single-photocatalyst systems? The answer may be "no". This

scheme still requires inhibitions of undesired e^- and h^+ transfer processes that induce "short circuiting" of photogenerated charge, as shown in **Fig. Z(b)**. Furthermore, the problem of spontaneous backward reaction of redox products, e.g., hydrogen and oxygen in water-splitting systems, still remains as in ordinary single-photocatalyst systems (See "Gibbs energy"). This might be the reason why such a long time has been required for realization of Z-scheme photocatalytic splitting of water under visible-light irradiation since Bard first suggested this concept in 1979 [82].

Known: Thermodynamic requirements for photocatalysts and a redox mediator.

Unknown: Strategy for inhibition of undesired possible e^- and h^+ transfer processes and of spontaneous backward reaction of redox products.

Conclusions

Revisiting the backgrounds and related discussion on photocatalysis, the author has found, surprisingly, many speculations, misunderstandings or misconceptions that have not been discussed in a scientific sense. Some of them were discussed in the recent review [4] to show a (personal) guideline for preparing articles on photocatalysis. In the present review, the author has attempted to describe again criticisms of scientific studies on photocatalysis, while the author hesitates to do so since he is also working in this field of photocatalysis. Then, why have those problems boiled up?

When the author started study on photocatalysis in 1981, as a Ph. D. course graduate student, there appeared to be no laboratories doing research work only on photocatalysis, i.e., photocatalysis studies were performed in laboratories devoted to studies on catalysis, electrochemistry, photochemistry, materials chemistry, etc. This means that results of those studies have been discussed, presumably, on the basis of different concepts, analytical methods or understanding depending on the field of each laboratory, and this might give rise to problems, presumably when a concept or a way of thinking used in a field, other than photocatalysis, was applied to discussion on photocatalysis without considering differences in definitions of terms

included in the concept or way of thinking. Therefore, we have to take care when they are applied newly to photocatalysis studies, considering their origins [83].

Another important point is to recognize the difference between "necessary" conditions and "sufficient" conditions. As is often the case, an experimental result seems to be proof of a certain hypothesis, when the result is just the same as that expected. However, results are always necessary conditions [84] and show probability of the hypothesis. This is not limited to studies on photocatalysis; scientific studies require such considerations.

It is time now to fix the field of "photocatalysis" having common unified understandings and concepts. It is the author's great pleasure if this review builds a momentum for unified understandings and concepts of photocatalysis.

Acknowledgments

This work was partly supported by Project to Create Photocatalyst Industry for Recycling-oriented Society supported by NEDO, New Energy and Industrial Technology Development Organization and Grant-in-Aid for "Scientific Research (A) (General)" from the Ministry of Education, Culture, Sports, Science and Technology (MEXT) of Japan.

References and notes

- [1] M. R. Hoffmann, S. T. Martin and W. Y. Choi, *Chem. Rev.* **95** (1995) 69.
- [2] The following reviews on photocatalysis have been published in this journal. (a) S. Ananda and M. Yoon, *this journal* **4** (2003) 5. (b) T. He and J. N. Yao, *ibid.* **4** (2003) 125. (c) D. Chatterjee and S. Dasgupta, *ibid.* **6** (2005) 186. (d) D. G. Shchukin and D. V. Sviridov, *ibid.* **7** (2006) 23. (e) V. Augugliaro, M. Litter, L. Palmisano and J. Soria, *ibid.* **7** (2006) 127. (f) U. I. Gaya and A. H. Abdullah, *ibid.* **9** (2008) 1. (g) K. Rajeshwar, M. E. Osugi, W. Chanmanee, C. R. Chenthamarakshan, M. V. B. Zanoni, P. Kajitvichyanukul and R. Krishnan-Ayer, *ibid.* **9** (2008) 171. (h) Y. Shiraishi, T. Hirai,

- ibid.* **9** (2008) 157.
- [3] (a) A. Fujishima, X. T. Zhang and D. A. Tryk, *Surf. Sci. Rep.* **63** (2008) 515. (b) A. Fujishima, X. Zhang and D. A. Tryk, *Int. J. Hydrogen Energy* **32** (2007) 2664.
- [4] B. Ohtani, *Chem. Lett.* **37** (2008) 216.
- [5] A. Fujishima and K. Honda, *Nature* **238** (1972) 37. The "Honda-Fujishima effect" is a well-known chemical phenomenon closely related to photocatalysis, and the paper published in *Nature* in 1972 had undoubtedly promoted research on photocatalysis but was not be an origin of heterogeneous photocatalysis in the bibliographic sense [3(a)].
- [6] Sometimes the term "active site" is used for a photocatalytic reaction system with dispersed chemical species, e.g., metal complexes or atomically adsorbed species, on support materials. Even in this case, a photocatalytic reaction occurs only when the species absorb light, and species not irradiated therefore cannot be active sites. A possible mechanism of photoinduced reaction is that photoirradiation produces stable "active sites" which work as reaction centers of thermal catalytic reactions, though this is different from the ordinary mechanism of photocatalysis by photoexcited electrons and positive holes.
- [7] Therefore, concepts of catalyst and photocatalyst are different and it can be stated, at least, that "a photocatalyst cannot be a photoirradiated catalyst" or "photocatalytic reaction cannot be induced by irradiation of a catalyst." However, many papers describe that the author(s) prepared a catalyst(s) and used it for photocatalytic reactions.
- [8] Of course, overall rate of photocatalytic reaction must depend on photoirradiation intensity and may be expressed with the rate constant as well as concentration of reaction substrate(s) and photoirradiation intensity.
- [9] In a recent paper of a collaboration work with the author, discussion of the ratio $k(\text{redox})/k(\text{recombination})$ was presented: S.-y. Murakami, H. Kominami, Y. Kera, S. Ikeda, H. Noguchi, K. Uosaki and B. Ohtani, *Res. Chem. Interm.* **33** (2007) 285.
- [10] It has been suggested that second-order rate constant of decay of photoinduced absorption

due to trapped electrons in titanium(IV) oxide photocatalysts can be a relative, but not absolute, measure of recombination rate constant, $k(\text{recombination})$. See "Mutual recombination".

- [11] In femto-second pump-probe transition photoabsorption measurements, titania photocatalysts gave visible-light photoabsorption of trapped e^- within ca. 100 fs pump pulse without showing photoabsorption of e^- in the CB. See "Mutual recombination".
- [12] Since the band structure of semiconductors, as well as insulators, consists of a filled valence band (VB) and vacant conduction band (CB), their Fermi level must be located between the VB and CB.
- [13] B. Ohtani, Y. Ogawa and S.-i. Nishimoto, *J. Phys. Chem. B* **101** (1997) 3746.
- [14] B. Ohtani, Y. Azuma, D. Li, T. Ihara and R. Abe, *Trans. Mater. Res. Soc. Jpn.* **32** (2007) 401.
- [15] B. Ohtani, O.O. Prieto-Mahaney, D. Li and R. Abe, *J. Photochem. Photobiol. A Chem.* in press. DOI:10.1016/j.jphotochem.2010.07.024
- [16] H. P. Klug and L. E. Alexander, X-Ray diffraction procedures for polycrystalline and amorphous materials (2nd edition), Wiley, New York (1974) p. 687.
- [17] R. Asahi, T. Morikawa, T. Ohwaki, K. Aoki and Y. Taga, *Science* **293** (2001) 269.
- [18] (a) D. Mitoraj, R. Beranek and H. Kisch, *Photochem. Photobiol. Sci.* **9** (2010) 31. (b) D. Mitoraj and H. Kisch, *Chem. Euro. J.* **16** (2010) 261.
- [19] X. Yan, T. Ohno, K. Nishijima, R. Abe and B. Ohtani, *Chem. Phys. Lett.* **429** (2006) 606. This paper claimed inappropriate use of organic dyes as test compounds for visible-light sensitive photocatalysts. Citation of this paper was not expected at all, since the authors using methylene blue (MB) as a model compound for photocatalytic reaction do not want to refer to this, and, on the other hand, those who do not use MB need not to refer to this. However, there has been an appreciable number of citations, and, to the author's surprise, approximately half of the citations of this paper were for reasonable use of MB, indicating

- that authors of those papers did not read the paper.
- [20] In other words, it is impossible to discuss "energy conversion efficiency" for reaction of negative Gibbs energy change as shown in **Fig. E (b)**.
- [21] It is thought that there should be at least ca. 200-mV "overpotential" in both reduction by e^- and oxidation by h^+ , and this shifts the limiting wavelength for water splitting by ca. 250 nm.
- [22] In this analysis of first-order kinetics, any value can be plotted against time of reaction, unless the value is proportional to the molar amount of a substrate or product; e.g., absorbance of a compound at a given wavelength can be used even if the molar absorption (extinction) coefficient is unknown and thereby absolute concentration cannot be determined. Moreover, taking the logarithm means a reciprocal value can also be used, e.g., $[A_0]/[A]$, where $[A_0]$ is initial concentration of a substrate A (See **Fig. F**).
- [23] Under these conditions, rate constant k obtained by the first-order kinetic analysis does not reflect the reactivity of a photocatalyst; k contains diffusion constant of a substrate and surface area of a photocatalyst (strictly speaking, area of diffusion layer on the "photoirradiated active" surface).
- [24] It should be noted that the overall rate obeys the first-order rate law in regard to surface concentration of a substrate but not concentration in the bulk.
- [25] In the lower concentration region of a Langmuir adsorption isotherm, similar linear dependence is also observed. However, if a given reaction condition lies in this region, a Henry-type adsorption isotherm, not a Langmuir-type one, should be used, since the most significant characteristic of a Langmuir isotherm is saturation at a high concentration.
- [26] Backward electron (hole) transfer can be avoided thermodynamically only when the CB bottom and VB top are more positive and negative than standard electrode potentials of a reductant and an oxidant, respectively.
- [27] A probable first report on photocatalytic liberation of hydroxyl radical: C. D. Jaeger and A.

- J. Bard, *J. Phys. Chem.* **83** (1979) 3146.
- [28] Recent papers on photocatalytic production of hydroxyl radical: (a) T. Hirakawa and Y. Nosaka, *Langmuir* **18** (2002) 3247. (b) Y. Nosaka, S. Komori, K. Yawata, T. Hirakawa and A. Y. Nosaka, *Phys. Chem. Chem. Phys.* **5** (2003) 4731. (c) B. Tryba, M. Toyoda, A. W. Morawski, R. Nonaka and M. Inagaki, *Appl. Catal. B Environ.* **71** (2007) 163. (d) Y. Murakami, K. Endo, I. Ohta and Y. Nosaka, *J. Phys. Chem.* **111** (2007) 11339. (e) T. Hirakawa, K. Yawata and Y. Nosaka, *Appl. Catal. A Gen.* **325** (2007) 105. (f) S. Sroiraya, W. Triampo, N. P. Morales and D. Triampo, *J. Ceram. Proc. Res.* **9** (2008) 146. (g) C. Y. Chang, Y. H. Hsieh, L. L. Hsieh, K. S. Yao and T. C. Cheng, *J. Hazard. Mater.* **166** (2009) 897, and references therein.
- [29] For example, M. Fleischmann, K. Korinek and D. Pletcher, *J. Electroanal. Chem.* **31** (1971) 39.
- [30] S.-i. Nishimoto, B. Ohtani, T. Yoshikawa and T. Kagiya, *J. Am. Chem. Soc.* **105** (1983) 7180. This opened up a way for photocatalytic organic syntheses, e.g., cyclic amino acid synthesis; (a) B. Ohtani, S. Tsuru, S.-i. Nishimoto, T. Kagiya and K. Izawa, *J. Org. Chem.* **55** (1990) 5551. (b) B. Ohtani, B. Pal and S. Ikeda, *Catal. Surveys from Asia* **7** (2003) 165.
- [31] In addition to this accidental coincidence of a peak position, authentic samples sometimes contains impurities giving chromatographic peaks, which are often misunderstood as peaks of authentic compounds. For example, commercial aqueous solutions of formaldehyde (formalin) generally contains methanol as a stabilizer. In gas-chromatography analysis using an FID (flame ionization detector), formaldehyde is not detected (no peak) but methanol gives a peak, which is often assigned to formaldehyde in error.
- [32] At least it is necessary to isolate and identify the product(s) when a given process is claimed to be applicable to practical synthetic process.
- [33] For example, A. J. Bard, *J. Phys. Chem.* **86** (1982) 172.

- [34] (a) S. Nakabayashi, A. Fujishima and K. Honda, *Chem. Phys. Lett.* **102** (1983) 464. (b) R. Baba, S. Nakabayashi, A. Fujishima and K. Honda, *J. Phys. Chem.* **89** (1985) 1902.
- [35] R. Abe, H. Takami, N. Murakami and B. Ohtani, *J. Am. Chem. Soc.* **130** (2008) 7780.
- [36] The height of the Schottky barrier, inducing a rectifying property, depends on the difference between Fermi level of an n-SC and standard electrode potential of an electrolyte solution but not on the donor concentration and electrode potential. This might be a reason why a rectifying property is observed for not only strongly reduced n-SC's with relatively high donor density but also particulate films with low donor density.
- [37] The first law of photochemistry, "Only the light which is absorbed by a molecule can be effective in producing photochemical change in the molecule" was formulated by Grotthus and Draper in the 19th century (J. G. Calvert, J. N. Pitts, Jr, *Photochemistry*, Wiley, New York (1966) p. 19.).
- [38] For turbid samples with light scattering, $\log(I_0/I)$ may be called "optical density".
- [39] Another point to check is adequate use of substrate concentration in analysis. Since a Langmuir isotherm is derived on the basis of the adsorption equilibrium between species adsorbed and desorbed in solution, the isotherm is a function of concentration of the adsorbate (molecules to be adsorbed on surfaces) in solution, not concentration of the adsorbate in feed. Therefore, the actual concentration, which must be reduced from that in feed due to appreciable adsorption, must be measured at least before photoirradiation.
- [40] In some reports on photocatalytic reaction, it has been stated that the time-course curve obeys the first-order rate law and that the rate of reaction changes following Langmuir-type adsorption behavior (so-called "Langmuir-Hinshelwood mechanism") when the substrate concentration is changed, though these two facts are incompatible. A possible situation is that a double reciprocal plot of rate and substrate concentration (**Fig. L (a)**) is linear but that the line passes through the origin, suggesting that the rate is

proportional to the substrate concentration.

- [41] As an example of papers showing the coincidence of equilibrium adsorption constants obtained from the photocatalytic reaction rate and adsorption in the dark, see: F. Amano, K. Nogami and B. Ohtani, *Langmuir* **26** (2010) 7174.
- [42] It should be noted that the concept of Langmuirian adsorption does not contain a meaning of "surface" and the isotherm is derived even assuming an equilibrium of reaction, production of associates of "surface adsorption site" and "adsorbate" in a homogeneous phase, as no interaction between surface adsorption sites are presumed. Such interactions are of significant characteristics of surfaces.
- [43] (a) D. P. Colombo, Jr. and R. M. Bowman, *J. Phys. Chem.* **99** (1995) 11752. (b) D. P. Colombo, Jr. and R. M. Bowman, *J. Phys. Chem.* **100** (1996) 18445. (c) D. P. Colombo, Jr., K. A. Roussel, J. Saeh, D. E. Skinner, J. J. Cavaleri and R. M. Bowman, *Chem. Phys. Lett.* **232** (1995) 207.
- [44] B. Ohtani, H. Kominami, R.M. Bowman, P. Colombo Jr., H. Noguchi and K. Uosaki *Chem. Lett.* **27** (1998) 579.
- [45] An example of a recent report: Y. Tamaki, K. Hara, R. Katoh, M. Tachiya and A. Furube, *J. Phys. Chem. C* **113** (2009) 11741.
- [46] A recent review on nanostructured titania photocatalysts: X. Chen and S. S. Mao, *Chem. Rev.* **107** (2007) 2891.
- [47] (a) F. Amano, O.O. Prieto-Mahaney, Y. Terada, T. Yasumoto, T. Shibayama and B. Ohtani *Chem. Mater.* **21** (2009) 2601. (b) B. Ohtani, F. Amano, T. Yasumoto, O.O. Prieto-Mahaney, S. Uchida, T. Shibayama and Y. Terada *Top. Catal.* **53** (2010) 455.
- [48] O.O. Prieto-Mahaney, N. Murakami, R. Abe and B. Ohtani *Chem. Lett.* **38** (2009) 238.
- [49] B. Ohtani, O.O. Prieto-Mahaney, F. Amano, N. Murakami and R. Abe *J. Adv. Oxidat. Tech.* **13** (2010) 247.
- [50] Correctly speaking, those descriptions suggest only that it is consistent to obtain a linear

- correlation in a plot assuming n to be 1/2 or 2 for direct or indirect transition, respectively, and there have been no suggestions for a way to determine the mode of transition.
- [51] This titania sample was supplied as a Japanese reference catalyst (JRC) TIO-3 from the Catalysis Society of Japan. After calcination at 1173 K for 2 h in air, the specific surface area was ca. $5 \text{ m}^2 \text{ g}^{-1}$.
- [52] Mode of transition, direct or indirect, of rutile (anatase) titania crystals seems to be still under discussion. Examples of band calculation are (a) K.-H.Hellwege, O.Madelung eds., *Landolt-Börnstein Numerical Data and Functional Relationships in Science and Technology, New Series*, Vol. 17 (Semiconductors) Springer-Verlag, Berlin (1984) p.414. [indirect], (b) S. D. Mo and W. Y. Ching, *Phys. Rev.* **B51** (1995) 13 023. [indirect]. This suggests difficulty in discrimination of the mode of transition from results of calculation (Band-gap energy estimated by calculation is often unreliable.).
- [53] It seems to be known in the field of photocatalysis that band-gap energies of anatase and rutile titania are 3.2 (387 nm) and 3.0 eV (413 nm), respectively, though the author does not know by whom and how those data were obtained.
- [54] This coefficient is often called "shape factor", but the author does not know the reason for this.
- [55] FWHM is generally evaluated by measuring width in diffraction angle at the height of half maximum as the term "FWHM" means, but there is another way for evaluation: an XRD peak is reproduced by a Gaussian curve or a triangle and then FWHM is measured.
- [56] The original paper on this plot is: G. K. Williamson and W. H. Hall, *Acta Metall.* **1** (1953) 22. The author has not checked discussion, if any, on this plot following the original paper.
- [57] In the field of polymer science, average molecular weight is calculated mainly in two modes: number average and weight average.
- [58] A problem of this method is that particles not detected in SEM or TEM images are not counted. Sometimes noble-metal deposits on solid surface are so small ($< 1 \text{ nm}$) that

they cannot be seen.

- [59] It is clear that measured specific surface area reflects surfaces of all particles and there is no dependence of sensitivity on particle size.
- [60] Y. Nosaka and A. Nosaka, *Nyumon Hikarishokubai* (Japanese), Tokyo Tosho, Tokyo (2004) p. 59.
- [61] J. G. Calvert and J. N. Pitts, Jr, *Photochemistry*, Wiley, New York (1966) p. 20.
- [62] This stoichiometry was clarified for the first time by the author's group and reported as: S.-i. Nishimoto, B. Ohtani, H. Kajiwara and T. Kagiya, *J. Chem. Soc., Faraday Trans. 1* **79** (1983) 2685. Before publication in this journal, we submitted a part of the experimental results to Chemistry Letters as the first paper in the author's career in the field of photocatalysis, but the paper was rejected presumably due to a reviewer's comment that the content had been reported in a Russian journal without showing bibliographic data (We could not find this.). To submit the results as a full paper, additional experiments were carried out to support the stoichiometry. For example, an oxygen-isotope experiment was performed and showed the origin of molecular oxygen to be water. As a result, we were able to have the paper published, and it has been cited more than 100 times, including recent citations. This is an example of rejection of a submitted paper not always being disadvantageous for the authors.
- [63] Oxygen can be liberated through the formation of hydrogen peroxide by a two-positive-hole process followed by disproportionation, a dark process, into oxygen and water. Overall, however, production of one molecule of oxygen requires four positive holes also in this case.
- [64] A recent paper from the author's group showed that P25 and an artificial mixture of isolated pure anatase and rutile (from P25) with amorphous material exhibited photocatalytic activities, in several reaction systems, which were at the level intermediate between those of pure isolated anatase and rutile, suggesting no synergetic effect [15].

- [65] Papers showing activation energy of photocatalytic reactions in the period 2000–2004. Figures and compounds in square brackets and parentheses, respectively, show activation energy in the unit of kJ mol^{-1} and substrate. (a) A. V. Vorontsov, I. V. Stoyanova, D. V. Kozlov, V. I. Simagina and E. N. Savinov, *J. Catal.* **189** (2000) 360. [10.9 (acetone)] (b) Y. M. Xu, *Chem. J. Chin. Univ. Chin.* **21** (2000) 1539. [4.2-4.6 (acetophenone)] (c) W. Y. Su, X. Z. Fu and K. M. Wei, *Chem. J. Chin. Univ. Chin.*, **22** (2001) 272. [13.7 (bromomethane)] (d) J. Lea and A. A. Adesina, *J. Chem. Tech. Biotech.*, **76** (2001) 803. [7.83 (nitrophenol)] (e) O. E. Kartal, M. Erol and H. Oguz, *Chem. Eng. Tech.* **24** (2001) 645. [16.2 (phenol)] (f) A. N. Okte, M. S. Resat and Y. Inel, *J. Catal.* **198** (2001) 172-178. [17.1 (1,3-dihydroxy-5-methoxybenzene)] (g) H. Tada, F. Suzuki, S. Yoneda, S. Ito and H. Kobayashi, *Phys. Chem. Chem. Phys.* **3** (2001) 1376-1382. [19.7/29.4 (bis(2-dipyridil)disulfide)] (h) N. C. Lee and W. Y. Choi, *J. Phys. Chem. B* **106** (2002) 11818. [18.7 (soot)] (i) W. Q. Cui, L. R. Feng, C. H. Xu, S. J. Lu and F. Qiu, *Chin. J. Catal.* **24** (2003) 937. [8.46 (methanol)] (j) D. V. Kozlov, A. A. Panchenko, D. V. Bavykin, E. N. Savinov and P. G. Smirniotis, *Russ. Chem. Bull.* **52** (2003) 1100. [6.3 ± 0.4 (benzene)] (k) A. Mills, G. Hill, S. Bhopal, I. P. Parkin and S. A. O'Neill, *J. Photochem. Photobiol. A Chem.* **160** (2003) 185. [19 (stearic acid)] (l) R. Al-Rasheed and D. J. Cardin, *Chemosphere* **51** (2003) 925. [17 ± 0.6 (fumic acid)] (m) J. C. Garcia and K. Takashima, *J. Photochem. Photobiol. A Chem.*, **155** (2003) 215-222. [24.8 (imazaquin)] (n) A. E. H. Machado, J. A. de Miranda, R. F. de Freitas, E. T. F. M. Duarte, L. F. Ferreira, Y. D. T. Albuquerque, R. Ruggiero, C. Sattler and L. de Oliveira, *J. Photochem. Photobiol. A Chem.* **155** (2003) 231. [7.9–10.5 (organic matter)] (o) S. Parra, S. E. Stanca, I. Guasaquillo and K. R. Thampi, *Appl. Catal. B: Environ.* **51** (2004) 107. [10.9 (atrazine)]
- [66] URL: <http://tredec.nrel.gov/solar/spectra/am1.5/>
- [67] The value 1000 mW m^{-2} is usually used in Japan as the total energy of AM1.5 radiation based on JIS C8911 (URL: <http://www.jisc.go.jp/app/pager?id=57836>), while the total

energy calculated using the table of ASTM is 1001.0 mW m^{-2} (Total energy claimed in the author's recent review [4], 958 mW m^{-2} , as well as the contents of ultraviolet light should be corrected.). The difference is presumably attributable to the difference in instruments used for the measurements.

- [68] A. Mills and J. Wang, *J. Photochem. Photobiol. A: Chem.* **127** (1999) 123.
- [69] Watanabe et al. reported similar action spectrum analysis of photoinduced degradation of Rhodamine B with a cadmium sulfide suspension and pointed out a similar dye-sensitization mechanism: T. Watanabe, T. Takizawa and K. Honda, *J. Phys. Chem.* **81** (1977) 1845. Photocatalytic reaction of MB in aerated titania suspensions was reported in 1937 by a Japanese photochemist: M. Horio, *Nihon Gakujutsu Kyokai Hokoku* **12** (1937) 204 (in Japanese). As far as the author knows, this is the first report on titania photocatalysis.
- [70] The fact that irradiation of a dye solution in the absence of a photocatalyst decomposes the dye negligibly has often been described in papers to support negligible photoinduced reaction by photoexcited dye molecules. However, the photoinduced electron injection requires an acceptor, such as titania, and thereby there are no ideal control experiments to exclude the possibility of photoinduced electron injection (See **Fig. V**).
- [71] When organic dyes themselves are pollutants to be decomposed, visible light-induced, but not photocatalytic, reaction can be a useful technique; X. Chen, Z. Zheng, X. Ke, E. Jaatinen, T. Xie, D. Wang, C. Guo, J. Zhao and H. Zhu, *Green Chem.* **12** (2010) 414.
- [72] This is based on the assumption of a linear light-intensity dependence of reaction rate.
- [73] T. Torimoto, Y. Aburakawa, Y. Kawahara, S. Ikeda and B. Ohtani, *Chem. Phys. Lett.* **392** (2004) 220. This paper showed that the rate of photocatalytic reaction in the presence of molecular oxygen, i.e., photocatalytic oxidative decomposition, may strongly depend on the intensity of light irradiation, while the rate of reaction in the absence of oxygen seems to be almost independent of the light intensity (See **Fig. Q (b)**).

- [74] Strictly speaking, when apparent quantum efficiency is discussed, the light intensity should be adjusted to be the same in number of photons, not in energy.
- [75] In the Japanese Industrial Standards (JIS B7113, discontinued), limiting transmission wavelength is defined as the center of wavelengths giving 72% and 5% transmission. For example, the limiting transmission wavelength for an Asahi Technoglass L-42 cut-off filter is 420 nm based on the standard, and this filter transmits ca. 60% at 420 nm. The number "42" indicates only that 420 nm is the limiting transmission wavelength defined in JIS, and practically irradiation at > 390 nm is made using this filter. Statements such as "visible-light irradiation at > 420 nm was performed using an optical sharp cut filter" seem misleading when L-42 has been used.
- [76] Sayama et al. reported for the first time photocatalytic water splitting into hydrogen and oxygen by an aqueous suspension of two kinds of photocatalysts under visible-light irradiation; K. Sayama, K. Mukasa, R. Abe, Y. Abe and H. Arakawa, *Chem. Commun.* (2001) 2416.
- [77] (a) R. Abe, K. Sayama and H. Sugiura, *J. Phys. Chem. B* **109** (2005) 16052. (b) R. Abe, T. Takata, H. Sugiura and K. Domen, *Chem. Commun.* (2005) 3829. (c) H. Higashi, R. Abe, A. Ishikawa, T. Tanaka, B. Ohtani and K. Domen, *Chem. Lett.* **37** (2008) 138. (d) M. Higashi, R. Abe and K. Domen, *Chem. Mater.* **21** (2009) 1543. (e) R. Abe, K. Shinmei, K. Hara and B. Ohtani, *Chem. Commun.* (2009) 3577. (f) A. Kudo, H. Kato and I. Tsuji, *Chem. Lett.* **33** (2004) 1534. (g) H. Kato, Y. Sasaki, A. Iwase and A. Kudo, *Bull. Chem. Soc. Jpn.* **80** (2007) 2457.
- [78] It seems to be "fallen Z" for the author.
- [79] For example, see: R. E. Blankenship, *Molecular Mechanisms of Photosynthesis*, Wiley, New York (2002) Chapter 1 (DOI: 10.1002/9780470758472.ch1).
- [80] If Gibbs energy change of the overall reaction is negative, i.e., energy releasing, use of two kinds of photocatalyst, requiring two photons for overall photocatalytic reaction, does

not make sense.

- [81] Recently Kudo et al. reported that a certain combination of two photocatalysts under controlled conditions works even without a redox mediator (See "Junction"): Y. Sasaki, H. Nemoto, K. Saito and A. Kudo, *J. Phys. Chem. C* **113** (2009) 17536.
- [82] A. J. Bard, *J. Photochem.* **10** (1979) 59.
- [83] During the course of writing this review, the author found that value of total energy of solar radiation, and hence contents of ultraviolet light, reported in the recent review [4] was incorrect due to simple miscalculation (See "Ultraviolet light in solar radiation"), suggesting we, at least I, have to think twice.
- [84] On the other hand, a hypothesis can be negated logically when at least one necessary condition does not hold true.

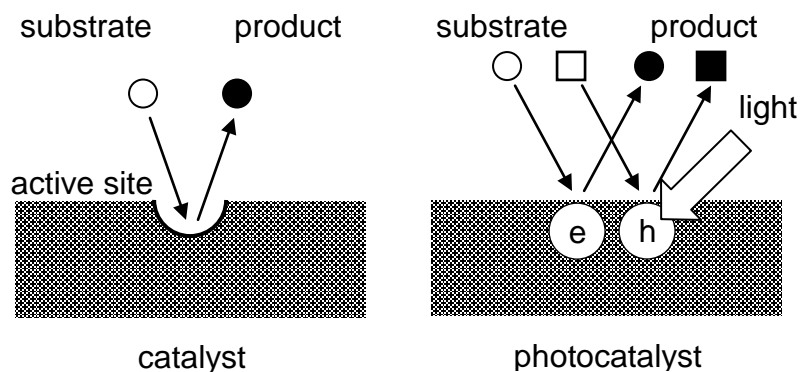

Fig. A Difference in concepts of catalytic and photocatalytic reactions: A catalyst contains active sites of which a substrate is converted into a product, while no active sites are present on a photocatalyst.

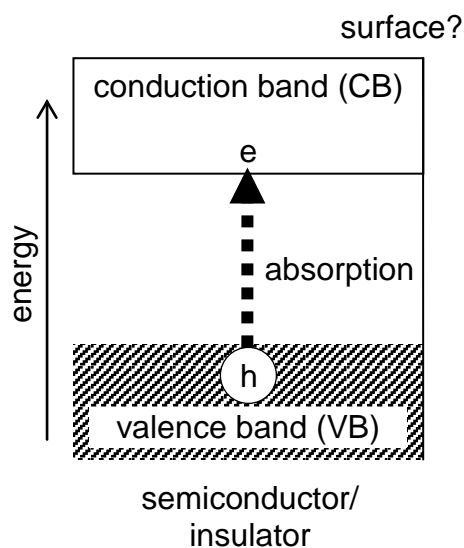

Fig. B Photoabsorption by transition of electrons in the valence band (VB) to the conduction band (CB) in a semiconductor.

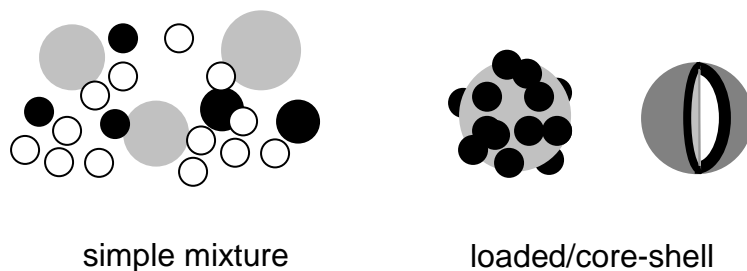

Fig. C Representative patterns of mixture of crystallites (white and gray particles) and amorphous parts (black).

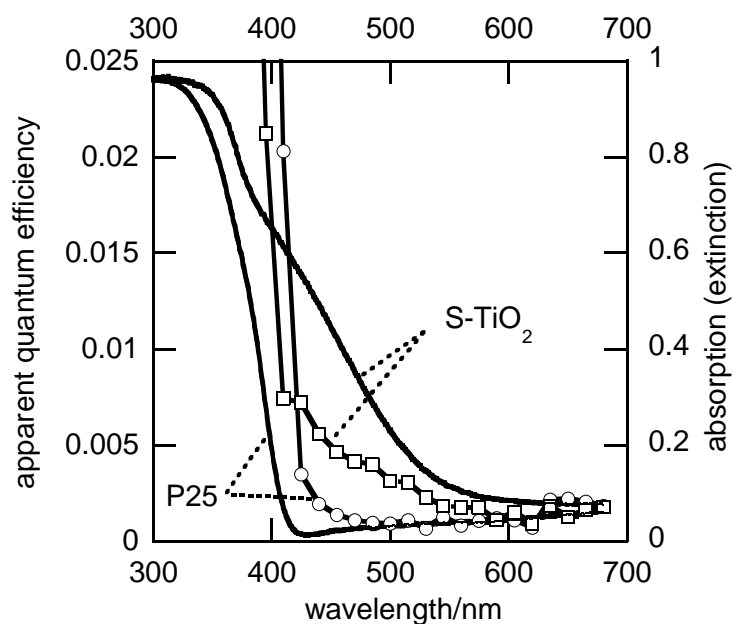

Fig. D Diffuse reflectance (photoabsorption) and action spectra for acetic acid decomposition in aerated aqueous solutions of sulfur-doped titania (S-TiO₂) and Degussa (Evonik) P25.

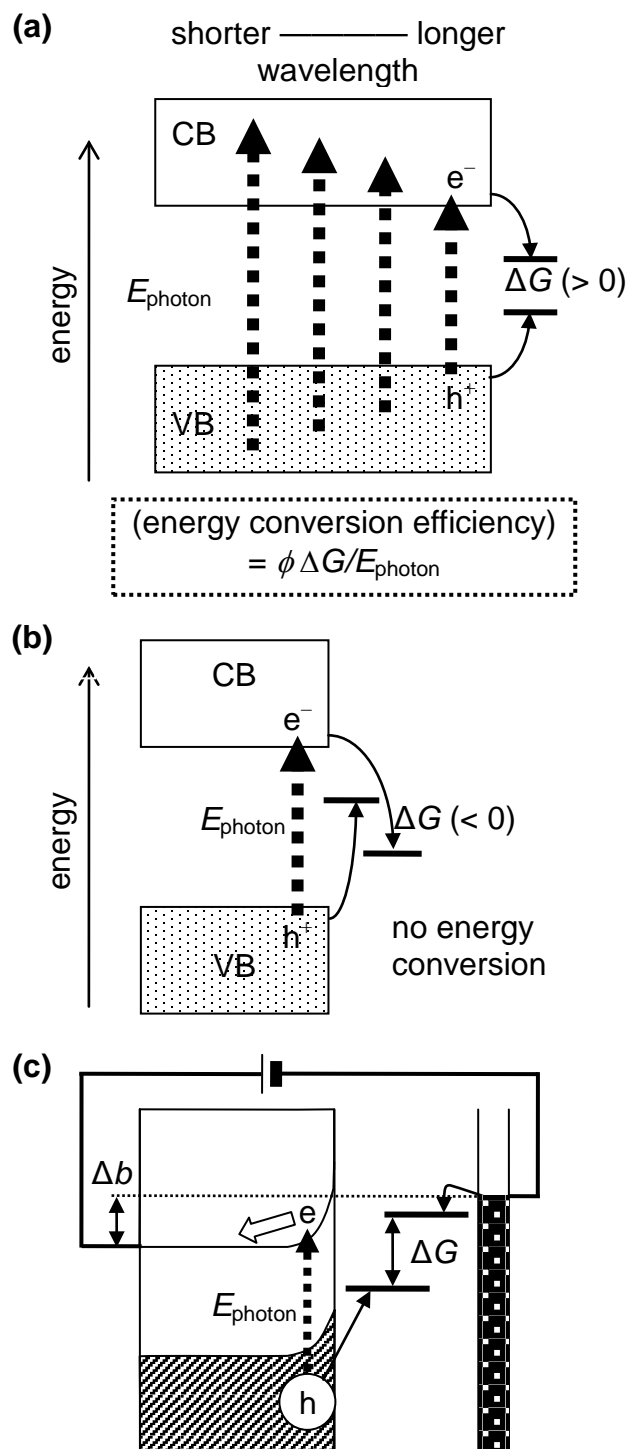

Fig. E (a) Light-to-chemical energy conversion efficiency of photocatalytic reaction calculated as an integral of a product of apparent quantum efficiency (ϕ) and Gibbs energy change (storage) divided by photon energy (E_{photon}) as a function of wavelength. (b) In the case where Gibbs energy change is negative, energy conversion efficiency can not be defined, or is defined to be zero. (c) Electrochemically biased (Δb) photoelectrochemical cell consisting of an n-type semiconductor and metal counter electrodes.

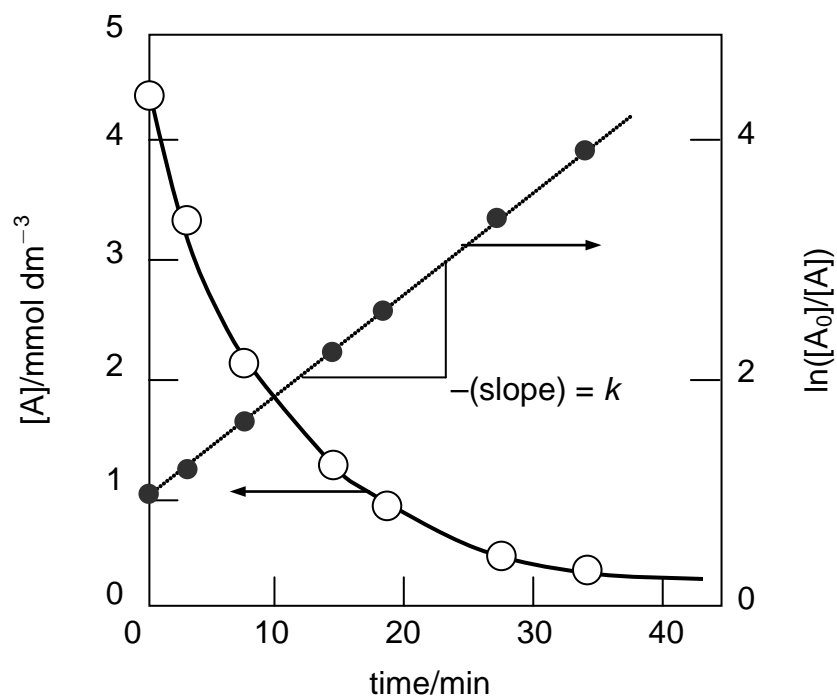

Fig. F First-order kinetic analysis for a reaction consuming a substrate A. Plot of logarithm of relative consumption (in the present plot, ratio of initial concentration of substrate A and concentration of A at a given time).

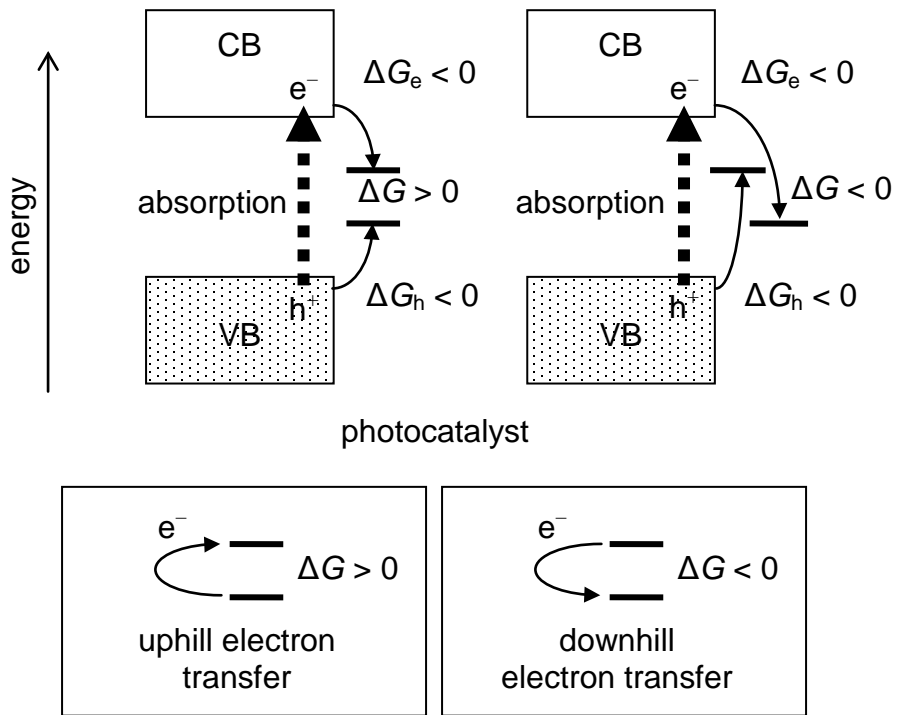

Fig. G Gibbs-energy change in photocatalytic reactions.

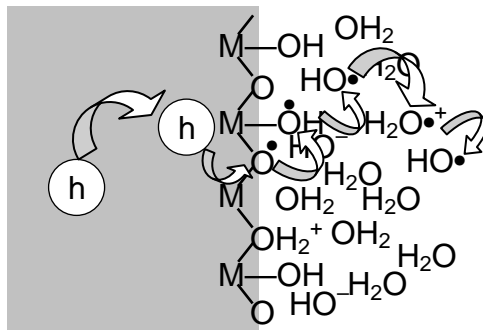
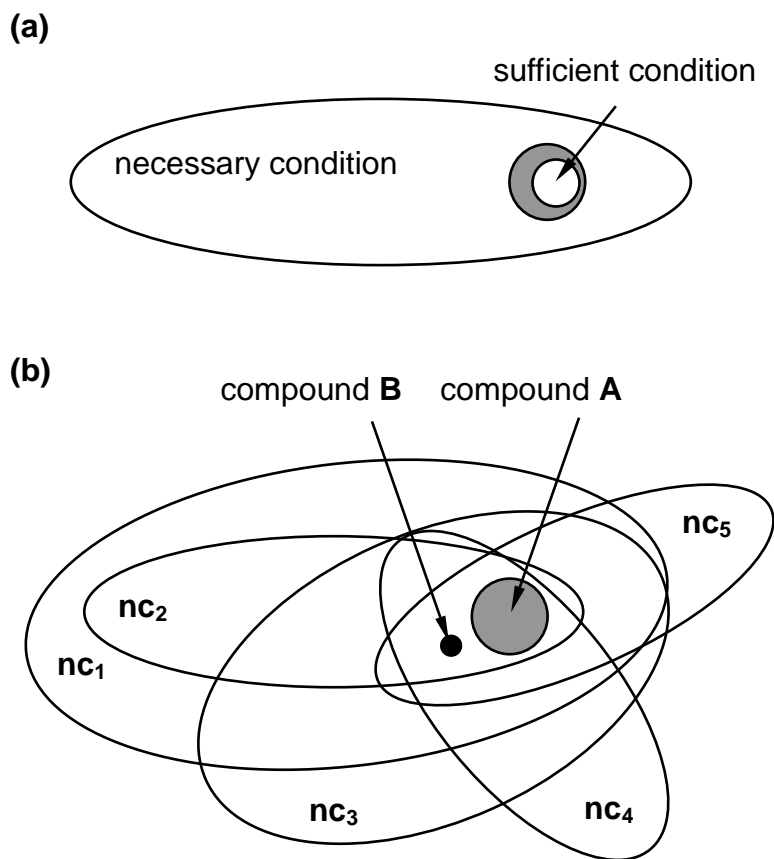

Fig. H Transfer of positive holes from the bulk of a photocatalyst through the interface to aqueous solution phase. Surface-adsorbed and free (hydrated) hydroxyl radicals and their derivatives can be a possible form of positive holes.



examples of necessary conditions (nc's)
for product identification: elemental
analysis, milli-MS, NMR, IR, TLC etc.

Fig. I (a) Schematic representation of truth, necessary condition (requirement) and sufficient condition. (b) Product identification by several analytical data. Even if all performed analyses support the structure of objective "compound A", those data are consistent with the assumption that the sample is compound A and there still is a possibility of "compound B".

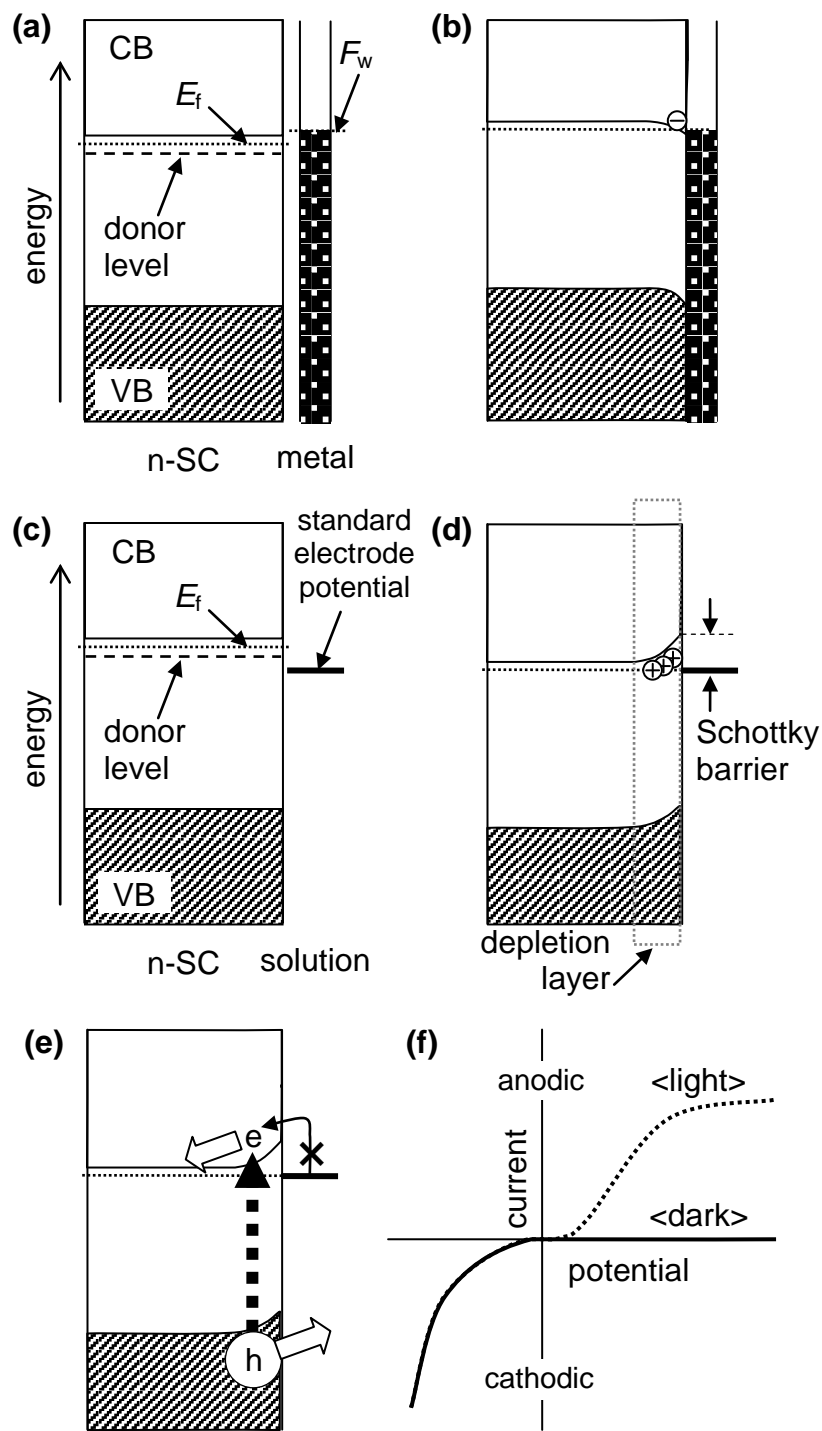

Fig. J (a) n-SC and metal with work function (F_w) and (b) ohmic contact between them. (c) N-type semiconductor (n-SC) and solution and (d) Schottky junction with a depletion layer where electrons in donor levels flew out to the solution to lower the Fermi level (E_F). (e) n-SC–electrolyte interface under photoirradiation and (f) ideal potential–current plots in the dark and under photoirradiation.

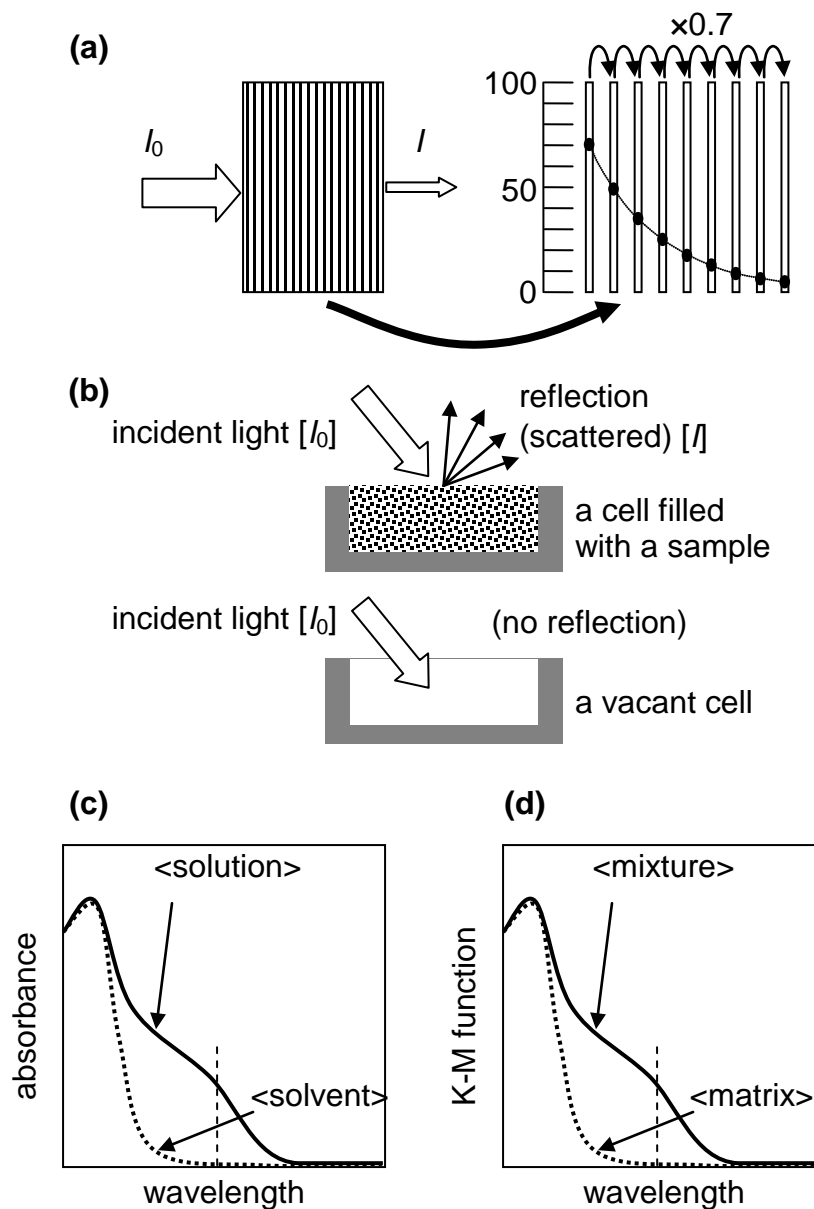

Fig. K (a) Logarithmic decrease in light intensity by absorption at constant (e.g. 30%) absorption at each thin layer. (b) Extinction (absorption and scattering) measurement for solid samples requires a standard sample which reflects incident light. Examples of measurements of (c) absorbance and (d) Kubelka-Munk function (K-M function) for homogeneous liquid and solid powder samples, respectively. Components in (c) solvent and (d) powder matrix give shoulder peaks and their absorbance and K-M function are proportional to their concentration, but not extent of photoabsorption in (c) solvent and (d) matrix, respectively.

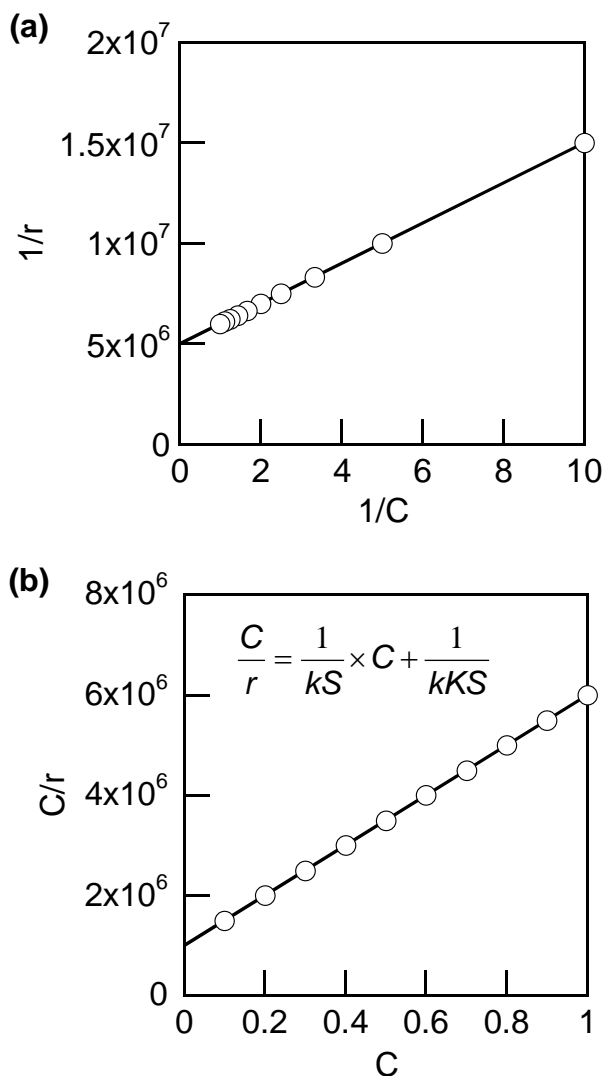

Fig. L Simulation of linearized plots for kinetics governed by surface concentration of substrates adsorbed on the photocatalyst surface in a Langmuirian fashion, where r , C , k , K and S are rate of reaction (mol s^{-1}), concentration of a substrate (mol L^{-1}), rate constant (10^{-4} s^{-1}), adsorption equilibrium constant (5 L mol^{-1}) and saturated amount of adsorption ($2 \times 10^{-3} \text{ mol}$).

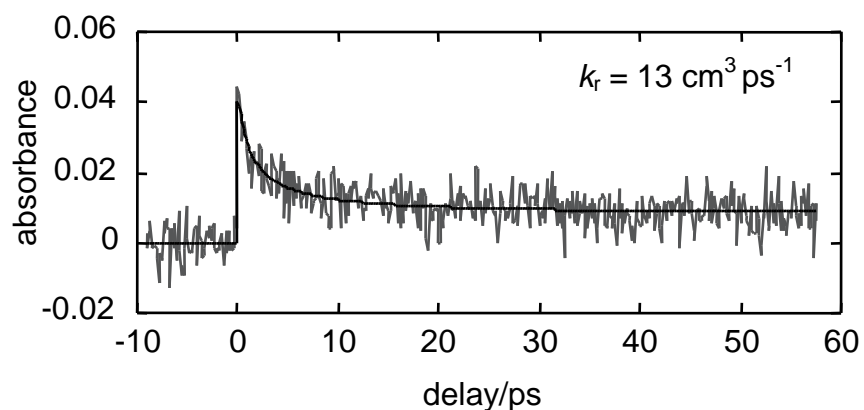

Fig. M An example of picosecond-time-region decay of photoabsorption (620 nm) of trapped electrons in Degussa (Evonik) P25 particles after excitation by a ca. 100-fs pump pulse (310 nm). The curve was analyzed by a second-order rate law (**eq. M**) with a baseline component (*BL*), and a second-order rate constant (k_r) was obtained to be $13 \text{ cm}^3 \text{ ps}^{-1}$.

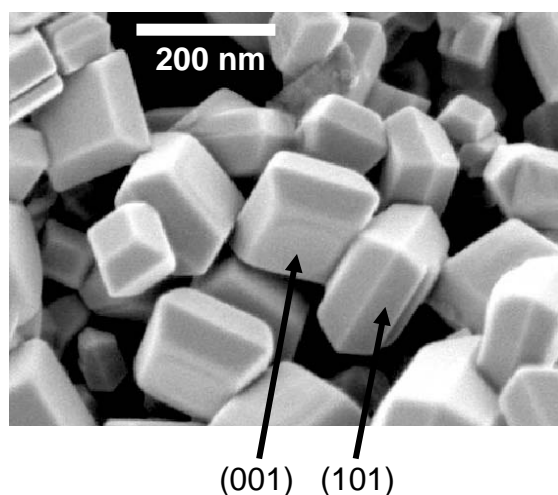

Fig. N A representative SEM image of decahedral anatase-titania particles prepared by controlled gas-phase reaction of titanium(IV) chloride and oxygen at 1473 K. Most particles expose two square (001) facets and eight trapezoidal (101) facets.

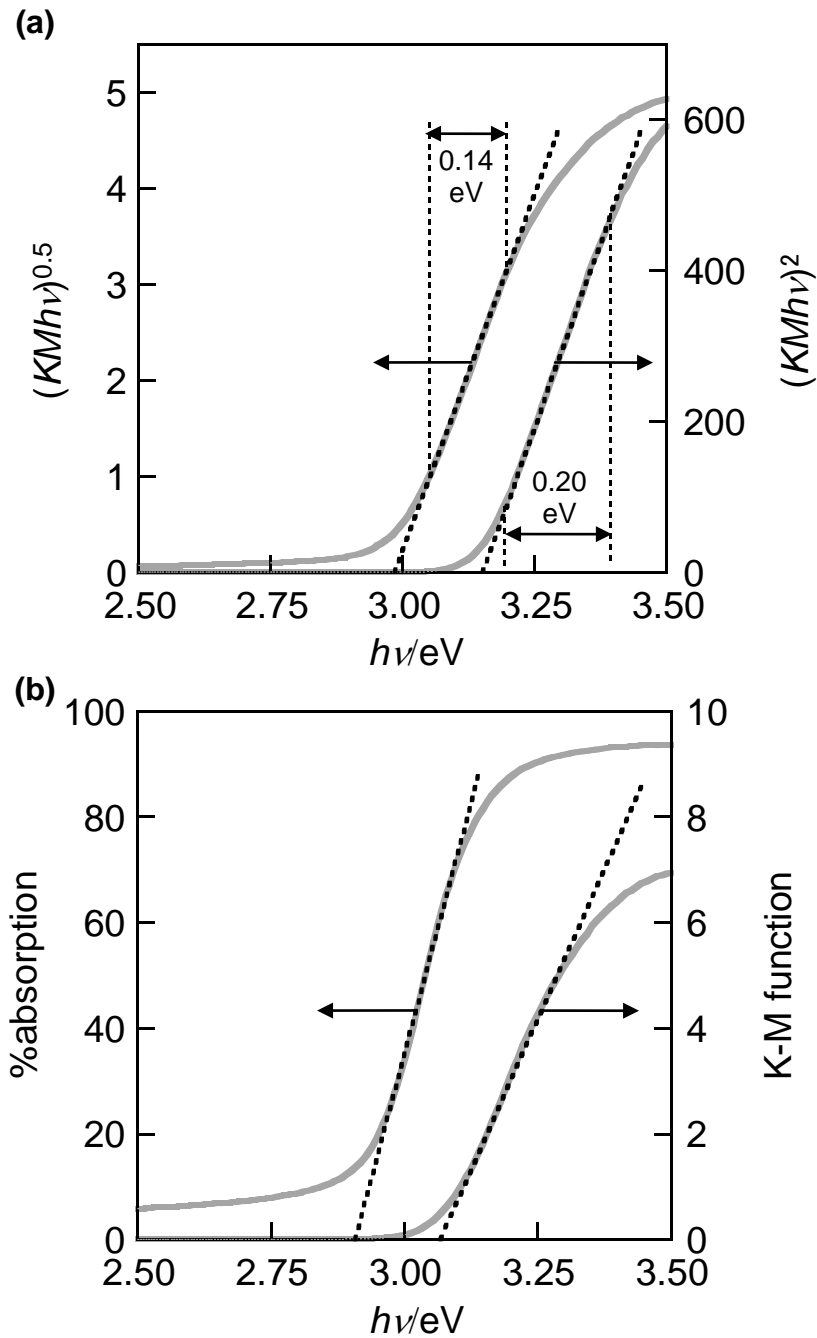

Fig. 0 (a) Two kinds of plot for determination of band-gap energy (E_g) of titania (JRC-TIO-3 calcined at 1173 K). Assumptions of indirect (left) and direct allowed transitions give band gaps of 3.00 and 3.14 eV, respectively. (b) Plots of %absorption (%extinction) and Kubelka-Munk function of the same sample. X-intercepts of lines fitting to the spectra in the absorption edge region are 2.91 and 3.07 eV, respectively.

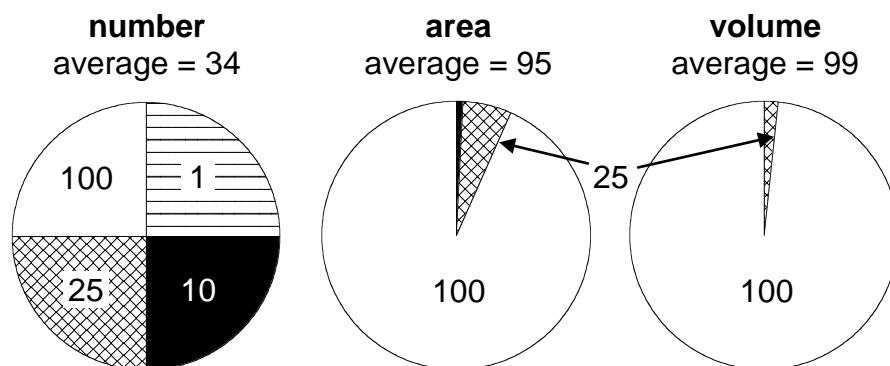

Fig. P Example of fractions of four kinds of particles (25% each in number) of size 1, 10, 25 and 100 nm in number, area and volume (weight). Figures in circle graphs show the particle size. Average size of particles is calculated on the basis of fractions.

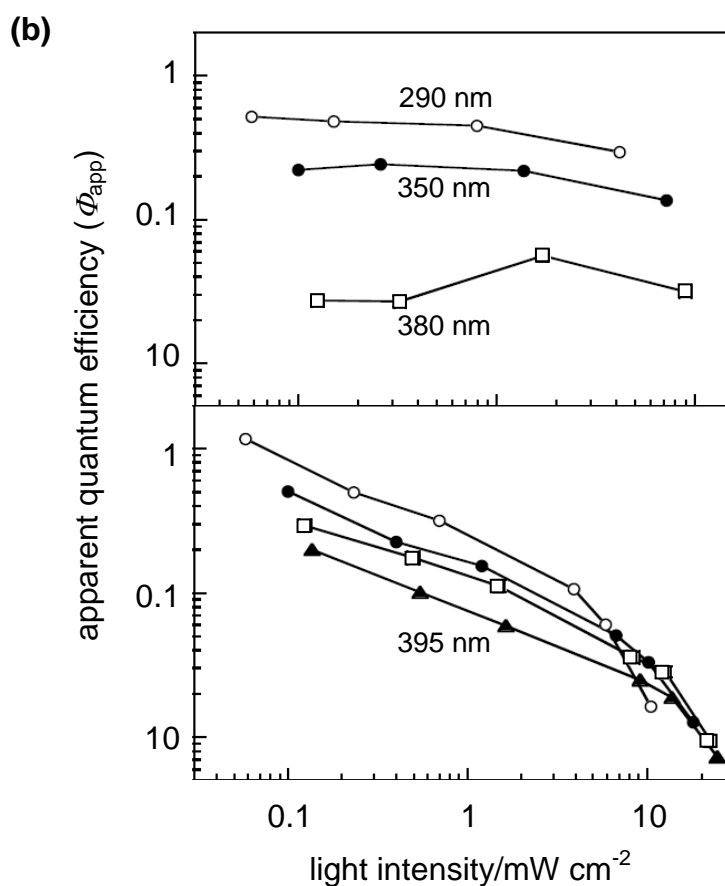
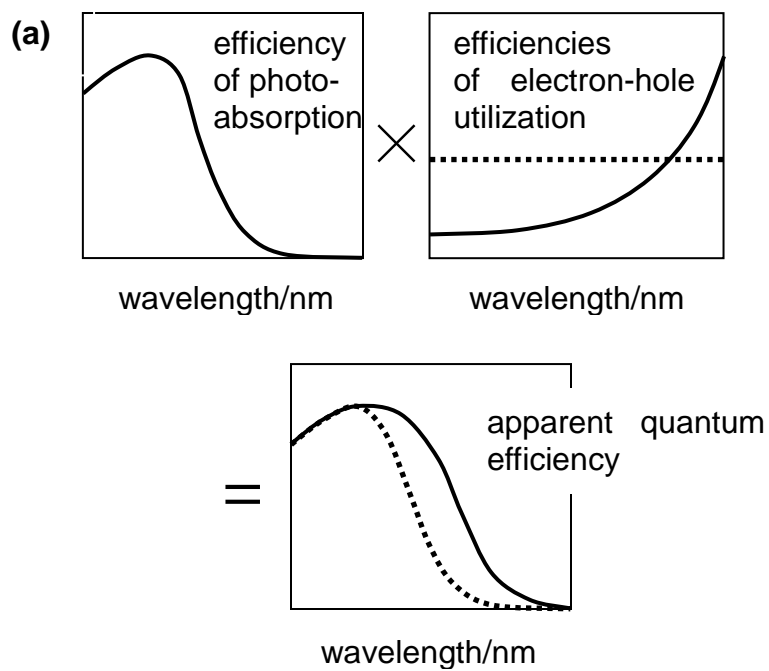

Fig. Q (a) Schematic representation of relations among photoabsorption, quantum and apparent quantum efficiencies. (b) Examples of dependence of apparent quantum efficiency on incident-light intensity at several wavelengths; (upper) dehydrogenation of methanol and (lower) oxidative decomposition of acetic acid. Merck titania was used as a photocatalyst.

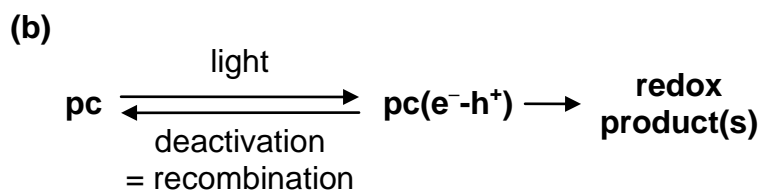
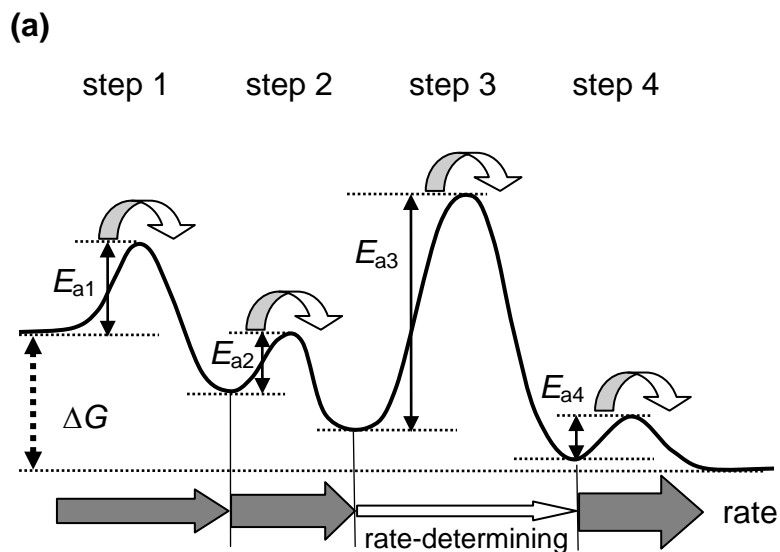

Fig. R (a) Model interpreting a rate-determining step in a 4-step series reaction. Step 3 with largest activation energy determines the overall rate. (b) Simplified scheme of photocatalytic reaction with a photocatalyst "pc". It is clear that this process is not a series reaction since a "deactivation step" is included.

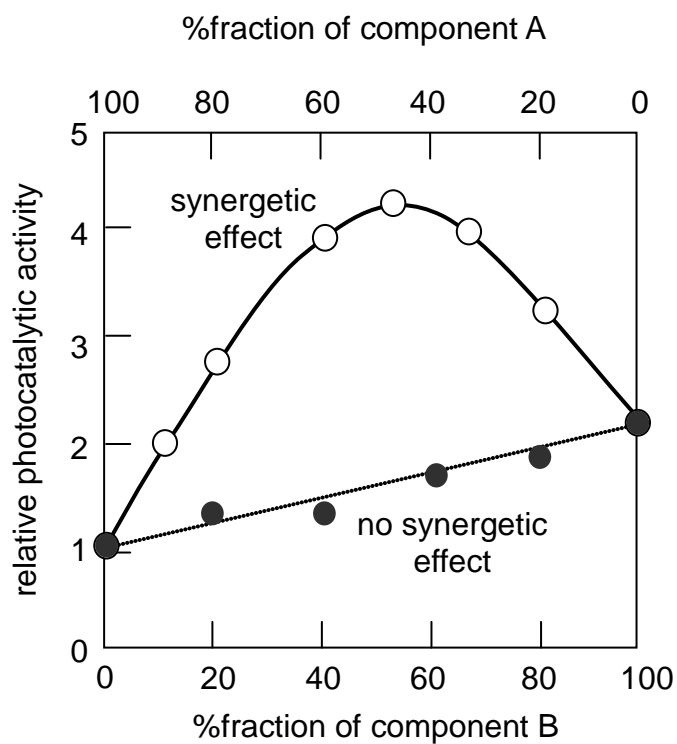

Fig. S Hypothetical representation of relative photocatalytic activities of mixtures of components A and B. A synergetic effect can be suggested at least when a mixture shows better photocatalytic activity compared with those of pure components A and B.

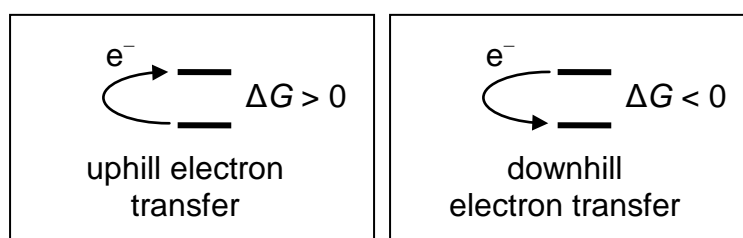
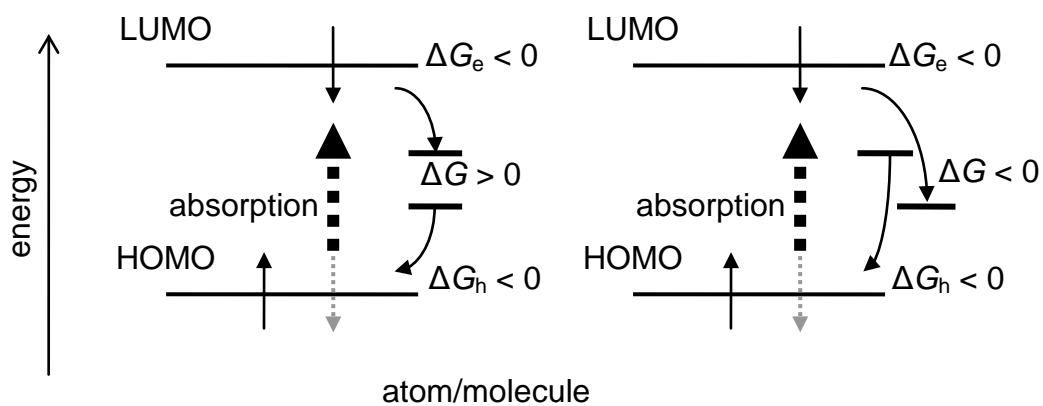

Fig. T Gibbs-energy change in photocatalytic reactions by a photocatalyst of a molecule or a highly dispersed compound.

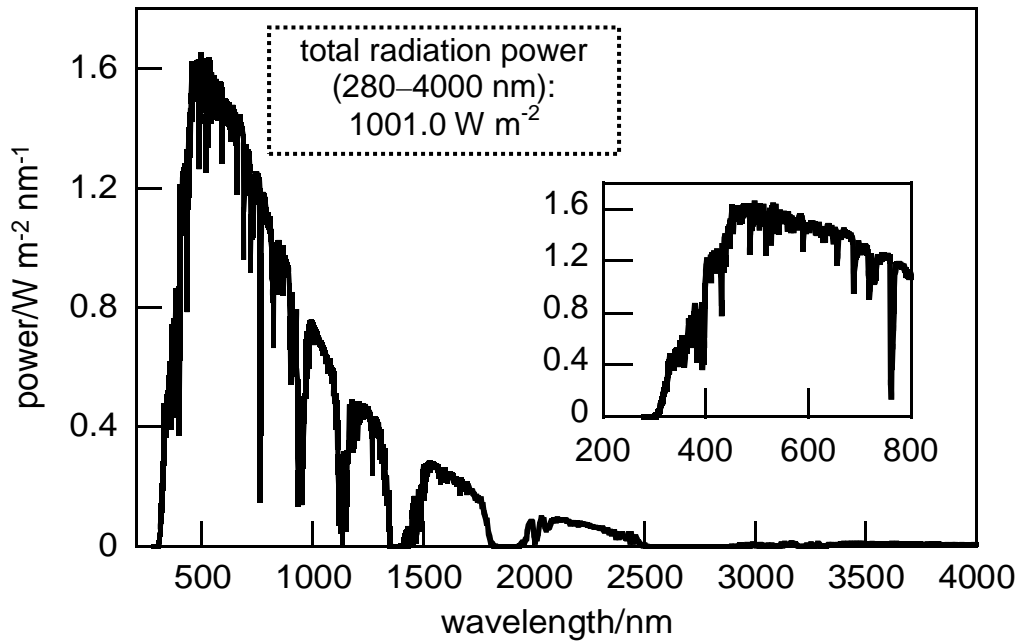

Fig. U A solar spectrum drawn on the basis of data of solar radiation at the ground surface in the temperate zone (AM1.5) reported by the American Society for Testing and Materials (ASTM, <http://www.astm.org/> ASTM). An inserted spectrum is a magnified drawing for a part of ultraviolet and visible light.

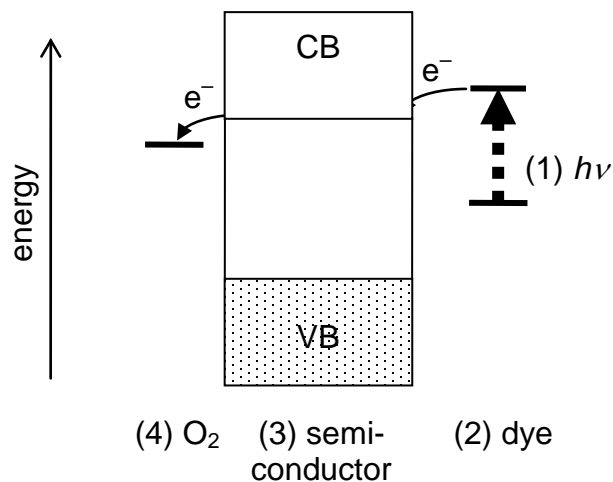

Fig. V Possible mechanism of "dye-sensitized" photoinduced oxidative decomposition of dye in the presence of oxygen. Components (1)–(4) are necessary conditions for "dye-sensitized reaction" and they are also necessary conditions for ordinary photocatalytic reaction.

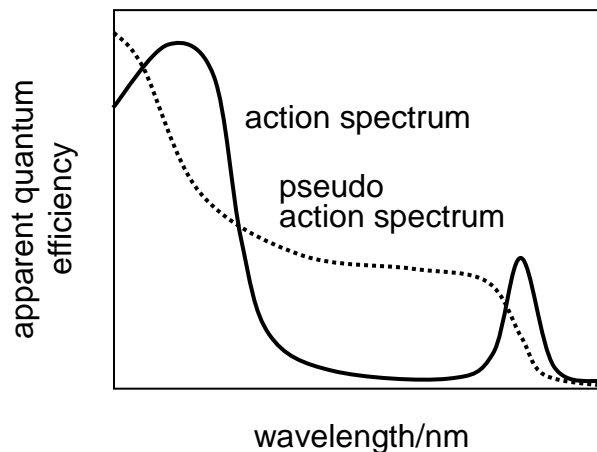

Fig. W Examples of action (solid line) and pseudo action (dotted line) spectra for photoinduced reaction by an ordinary semiconductor photocatalyst (shorter wavelength) and an organic dye (longer wavelength peak). A pseudo action spectrum taken by cut-off filters corresponds to integration of the "true" action spectrum from the longer-wavelength side.

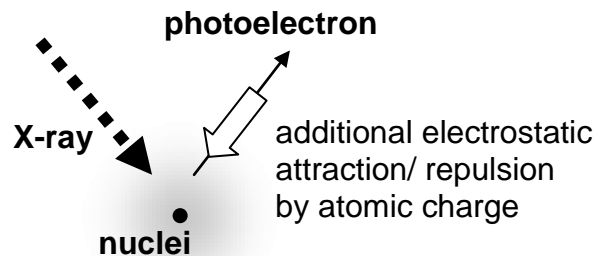

Fig. X Chemical shift in X-ray photoelectron spectra appears by interaction or repulsion by possible positive charge when photoelectrons are escaping from atomic nuclei, while no effect of neighboring atoms is expected.

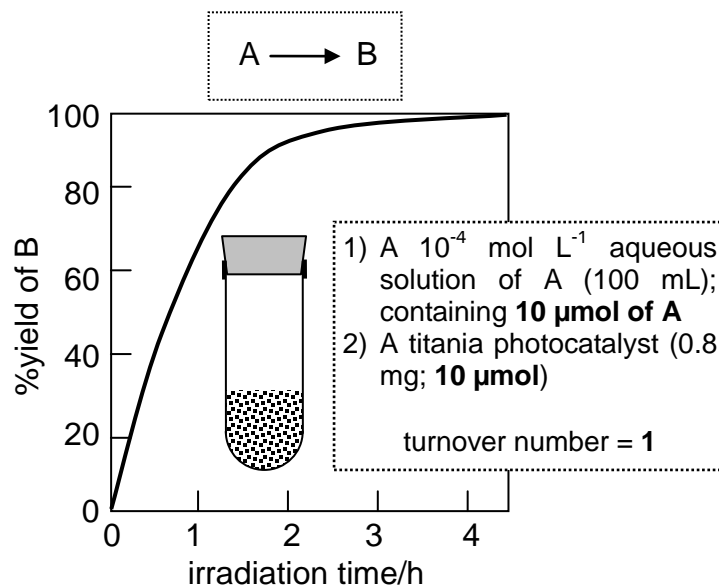

Fig. Y An example of calculation of turnover number in photocatalytic conversion of A into B. %Yield can not show turnover of the photocatalyst.

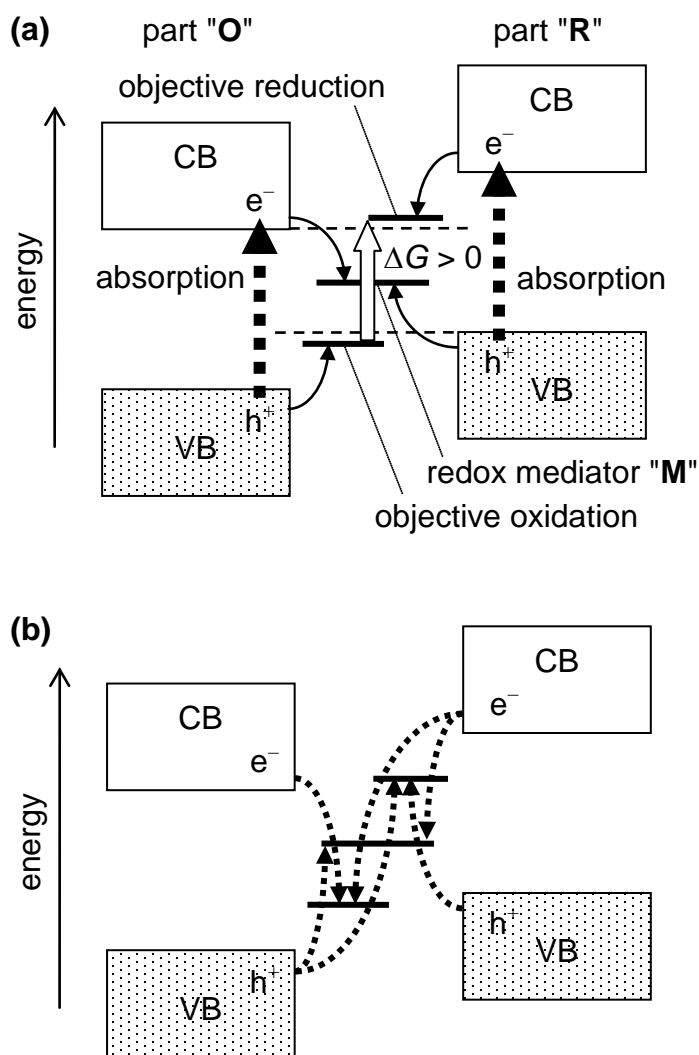

Fig. Z (a) A Z-scheme reaction combining two semiconductor photocatalytic reaction parts ("R" and "O") with a redox mediator "M". (b) Undesired possible e^- and h^+ transfer processes in a Z-scheme inducing "short circuiting" of a target reaction.