



HOKKAIDO UNIVERSITY

| | |
|------------------|---|
| Title | Cribrimorph and Other Cauloramphus Species (Bryozoa: Cheilostomata) from the Northwestern Pacific |
| Author(s) | Dick, Matthew H; Mawatari, Shunsuke F; Sanner, JoAnn et al. |
| Citation | Zoological Science, 28(2), 134-147 https://doi.org/10.2108/ZSJ.28.134 |
| Issue Date | 2011-02 |
| Doc URL | https://hdl.handle.net/2115/49370 |
| Rights | http://www.zoology.or.jp/html/02_magazine/02_index.htm |
| Type | journal article |
| File Information | NW Pac Caulo 2011.pdf |



Cribrimorph and Other *Cauloramphus* Species (Bryozoa: Cheilostomata) from the Northwestern Pacific

Matthew H. Dick^{1*}, Shunsuke F. Mawatari¹, JoAnn Sanner²
and Andrei V. Grischenko³

¹Department of Natural History Sciences, Faculty of Science, Hokkaido University, N10 W8, Sapporo 060-0810, Japan

²Department of Paleobiology, Smithsonian Institution, NMNH, MRC121, P.O. Box 37012, Washington, D.C. 20013-7012, USA

³Department of Invertebrate Zoology and Aquatic Ecology, Biological Faculty, Perm State University, Bukirev Street 15, GSP, 614900, Perm, Russia

We provide original descriptions for nine new species in the cheilostome bryozoan genus *Cauloramphus* (*C. gracilis*, *C. ordinarius*, *C. amphidisjunctus*, *C. cheliferooides*, *C. oshurkovi*, *C. infensus*, *C. parvus*, *C. peltatus*, and *C. ascofer*) and a redescription of *C. disjunctus* Canu and Bassler, 1929. We delineate a group of eight species, here termed the '*C. disjunctus* clade,' that have the opesial spine joints calcified to a greater or lesser extent in mature zooids; most also have paired, hypertrophied avicularia. This group includes *C. amphidisjunctus*, *C. cheliferooides*, *C. infensus*, *C. parvus*, *C. peltatus*, and *C. ascofer* in the Aleutian Islands, Alaska; *C. oshurkovi* in the Commander Islands; and *C. disjunctus* in Japan. High levels of apparent endemism in two unrelated bryozoan genera (*Cauloramphus* and *Monoporella*), and geographical population differentiation in *C. ascofer* indicating ongoing allopatric speciation, suggest high speciation rates for deep benthic bryozoans in the western Aleutians. A phylogenetic hypothesis for the *C. disjunctus* clade indicates that populations of *Cauloramphus* dispersed between the Aleutians and Asia on at least three separate occasions, and that the polarity of at least two of these dispersal events was from the Aleutians to Asia.

Key words: Bryozoa, *Cauloramphus*, Cheilostomata, *disjunctus* clade, dispersal, diversity, new species, phylogeny, speciation

INTRODUCTION

Anascan-grade cheilostome bryozoans in the large paraphyletic family Calloporidae typically have a well-exposed frontal membrane (non-calcified frontal wall), often have articulated circum-opesial spines surrounding the frontal membrane, and usually have a prominent hyperstomial ovicell. Within Calloporidae, species of *Cauloramphus* Norman, 1903, are unusual in having, in addition to circum-opesial spines, avicularia attached to the lateral gymnocyst by a flexible cuticular joint, a reduced kenozooidal oecium (Ostrovsky et al., 2007), and internal brooding.

At the start of this study, 21 valid Recent species of *Cauloramphus* had been described worldwide. Most species are distributed in cool-temperate waters around the North Pacific rim. Some, however, have circumpolar Arctic (e.g., *C. cymbaeformis*) or amphi-Boreal (e.g., *C. spinifer*) distributions, and a few range into the Subtropics or Tropics, usually in deeper water, e.g., *C. brunea* Canu and Bassler,

1930, in the Galapagos and *C. opertus* Canu and Bassler, 1928, in the Gulf of Mexico.

Dick et al. (2009) illustrated and provided brief morphological descriptions of what they identified as *Cauloramphus disjunctus* and three other, undescribed *Cauloramphus* species from the western Aleutian Islands, Alaska; two of these species have a cribrimorph costal shield and provide a remarkable example of the parallel evolution of complex characters. Upon examination of the type series for *C. disjunctus*, we concluded that none of the Aleutian or the Commander species is *C. disjunctus*, but that several of them (including the cribrimorph species) having hypertrophied, paired avicularia like those in *C. disjunctus* comprise a monophyletic group within *Cauloramphus*, which we term the '*C. disjunctus* clade.'

Here we formally describe eight new species of *Cauloramphus* from the shelf zone at depths of 80–415 m in the western Aleutian Islands, Alaska (Dick, 2008), including the species briefly described and illustrated in Dick et al. (2009); describe one new species collected subtidally from the Commander Islands to the west; and redescribe *C. disjunctus* Canu and Bassler, 1929. We also present a hypothesis on the phylogeny of the *C. disjunctus* clade, based on morphology and previous molecular data.

* Corresponding author. Phone: +81-11-706-2755;
Fax : +81-11-746-0862;
E-mail: mhdick@mail.sci.hokudai.ac.jp

We first present taxonomic descriptions, which establish the names of the species included in the study. We suggest that the reader interested more in distribution, local diversity, and phylogeny than in taxonomy skim the figures in the taxonomic section for a rough idea of the morphologies involved, and then proceed to the following section, entitled 'General Results and Discussion.'

MATERIALS AND METHODS

Most of the specimens included in this study were among collections made by M. Dick from 45 otter-trawl tows at 40 sampling stations (two or three tows were made at three of the stations) in the western Aleutian Islands (Fig. 1) at depths of 50–467 m, from 20 July to 2 August 2004. Collecting was conducted aboard *F/V Sea Storm*, chartered by the Alaska Fisheries Science Center, U.S. National Marine Fisheries Service.

The study area, details of collection, preparation of specimens, and examination by scanning electron microscopy were as described by Dick (2008). In some cases, dried specimens were coated for SEM and images were taken; the same specimens were then bleached, rinsed, dried, and re-coated, and additional SEM images were taken. Collection data are given in Table 1. Type material has been deposited in the Yale Peabody Museum (YPM), Yale University, New Haven, CT, USA, and The Natural History Museum (NHM), London, UK. To conserve space, locality information in the "Material examined" sections for the Aleutian species is indicated only by sampling station, with information on the stations given in Table 1.

Most measurements were taken at 80X magnification with an ocular micrometer attached to a Nikon SMZ-10 stereoscopic microscope. Measurements from type specimens of *C. disjunctus* and from the Kamchatka specimen of *C. ascofer* were made from SEM images by using ImageJ v. 1.42q software (<http://rsb.info.nih.gov/ij>). Measurements in the text are in millimeters. Sample sizes for measurements and counts are given as numbers of zooids and colonies; for example, (n = 30, 2) indicates 15 zooids per colony measured for each of two colonies. Abbreviations for measurements are: ZL, autozooid length; ZW, autozooid width; OpL, opesia length; OpW, opesia width; OrL, orifice length; OrW, orifice width (the orifice measurements were applicable only to *C. ascofer*); AvL, avicularium length from base of peduncle to tip; AvD, maximum avicularium depth in frontal-abfrontal (rostral-abrostral) direction. Mean values of measurements and spine counts for all species are presented in Table 2, which serves as a tabular key to the species.

While the spines in *Cauloramphus* are literally all circum-opesia, we define three categories of spines that can differ in form and number: *orificial spines*, located distal or lateral to the orifice; *opesial spines*, occurring on the mural rim proximal to the level of the orifice and usually angled over the opesia; and *intermediate spines*, usually one pair that, if present, is located lateral or proximal to the orifice between the orificial and opesia spines, and differs in form, size, and/or orientation from either type. Not all species show intermediate spines; as clear examples, *C. ascofer* has four orificial spines but no intermediate spines (Fig. 8A), whereas *C. peltatus* has two orificial and two much heavier intermediate spines (Fig. 7A).

We documented two other potentially useful characters that have not been employed before in *Cauloramphus* taxonomy. One is the position of attachment of the avicularia. This is determined from zooids having the modal number of orificial spines for a particular colony or population by counting spines in the proximal direction starting from the most distal single (if the modal number of orificial spines includes an unpaired median spine) or paired spine on one side. An attachment point of '3/4' means attachment on the lateral gymnocyst between the 3rd and 4th spines on either side, counting from the distal end; '2' indicates attachment lateral to the 2nd spine on either side, counting from the distal end. The other character is the length to depth ratio of the avicularium, or AvL/AvD.

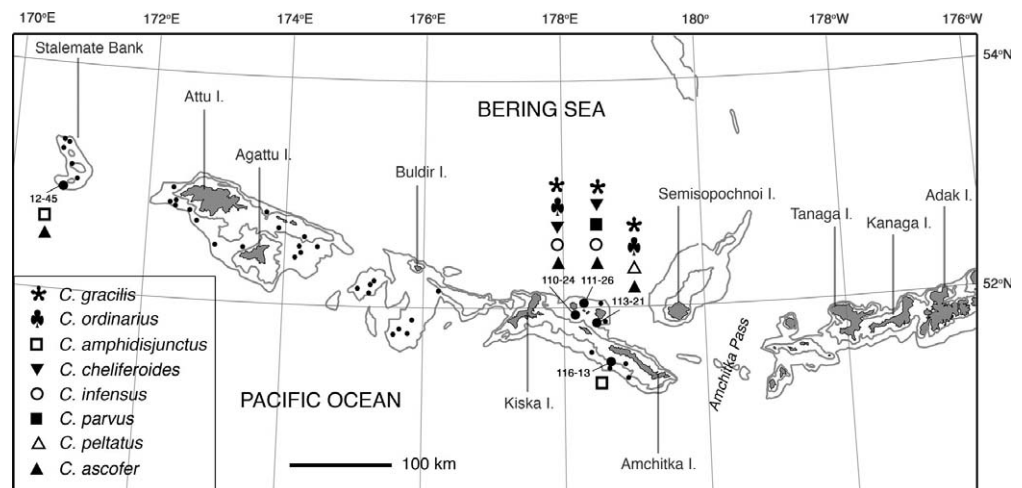

Fig. 1. Map of the western Aleutian Islands (west of Amchitka Pass) and part of the central Aleutian Islands (east of Amchitka Pass). Islands are indicated by dark-gray shading, with the main islands labeled; the 100 m and 500 m depth contours are shown in light gray. Filled circles indicate the 40 sampling stations where bryozoans were collected in 2004, with the smaller filled circles indicating that no specimens of *Cauloramphus* species were found in the sample. The larger filled circles labeled with station numbers indicate stations where one or more *Cauloramphus* species were found, with other symbols (key, lower left) indicating the complement of species.

Table 1. Information on sampling stations in the western Aleutian Islands, Alaska, USA, at which *Cauloramphus* specimens were collected.

| Station | Locality | Latitude | Longitude | Depth | Bottom temp. (°C) | Collection Date |
|---------|-------------------|-----------|------------|-------|-------------------|-----------------|
| 12-45 | Stalemate Bank | 52°54.7'N | 170°49.0'E | 189 m | 4.0 | 30 July 2004 |
| 110-24 | Rat Island group | 51°58.4'N | 178°13.5'E | 95 m | 4.9 | 22 July 2004 |
| 111-26 | Rat Island group | 52°03.7'N | 178°17.8'E | 355 m | 4.0 | 22 July 2004 |
| 113-21 | Rat Island group | 51°51.6'N | 178°27.8'E | 227 m | 4.3 | 23 July 2004 |
| 116-13 | S. of Amchitka I. | 51°29.5'N | 178°40.5'E | 156 m | 4.5 | 20 July 2004 |

Table 2. Summary of measurements, other characters, and geographical range for *Cauloramphus* species treated in this study. Measurements are mean values in millimeters and spine counts are modal values. For sample sizes, and ranges and standard deviations of measurements, refer to the species accounts in the text. For *C. ascofer*, the two values indicate separate measurements from the Stalemate Bank and Rat Island populations, respectively.

| ZOID MEASUREMENTS AND AVICULARIUM RATIO | | | | | | | |
|---|--------------|-------------|---------------|--------------|--------------------|-------------------|-----------------------|
| | Zooid length | Zooid width | Opesia length | Opesia width | Avicularium length | Avicularium depth | Avicularium L/D ratio |
| <i>C. gracilis</i> | 0.94 | 0.65 | 0.68 | 0.41 | 0.79 | 0.12 | 6.6 |
| <i>C. ordinarius</i> | 0.74 | 0.51 | 0.49 | 0.26 | 0.17 | 0.07 | 2.4 |
| <i>C. disjunctus</i> | 0.53 | 0.36 | 0.35 | 0.19 | 0.23 | 0.09 | 2.6 |
| <i>C. amphidisjunctus</i> | 0.64 | 0.44 | 0.38 | 0.20 | 0.30 | 0.13 | 2.3 |
| <i>C. cheliferooides</i> | 0.56 | 0.40 | 0.33 | 0.19 | 0.24 | 0.13 | 1.8 |
| <i>C. oshurkovi</i> | 0.49 | 0.39 | 0.32 | 0.20 | 0.27 | 0.16 | 1.7 |
| <i>C. infensus</i> | 0.61 | 0.42 | 0.43 | 0.24 | 0.43 | 0.17 | 2.5 |
| <i>C. parvus</i> | 0.44 | 0.30 | 0.29 | 0.25 | 0.24 | 0.09 | 2.7 |
| <i>C. peltatus</i> | 0.66 | 0.43 | – | – | 0.19 | 0.08 | 2.4 |
| <i>C. ascofer</i> | 0.72 / 0.62 | 0.49 / 0.43 | – | – | 0.14 / 0.16 | 0.06 / – | 2.3 / – |

| OTHER CHARACTERS AND GEOGRAPHICAL RANGE | | | | | | | |
|---|----------------------|------------------|---------------------|----------------|--------------|------------|-------------------------|
| | Avicularium position | Orificial spines | Intermediate spines | Opesial spines | Total spines | Cryptocyst | Known range |
| <i>C. gracilis</i> | 5/6 | 8 | 2 | 15 | 25 | smooth | W. Aleutians |
| <i>C. ordinarius</i> | 4/5 | 5 | 0 | 11 | 16 | tubercles | W. Aleutians |
| <i>C. disjunctus</i> | 4/5 | 4 | 2 | 17 | 23 | smooth | Japan |
| <i>C. amphidisjunctus</i> | 3/4 | 2 | 2 | 13 | 18 | smooth | W. Aleutians |
| <i>C. cheliferooides</i> | 3/4 | 2 | 2 | 11, 12 | 15, 16 | smooth | W. Aleutians |
| <i>C. oshurkovi</i> | 3/4 | 2 | 2 | 7 | 11 | smooth | Commander Is. |
| <i>C. infensus</i> | 4/5 | 6 | 0 | 12 | 18 | tubercles | W. Aleutians |
| <i>C. parvus</i> | 3/4 | 2 | 2 | 14 | 18 | smooth | W. Aleutians |
| <i>C. peltatus</i> | 3 or 3/4 | 2 | 2 | 18 | 22 | smooth | W. Aleutians |
| <i>C. ascofer</i> | 2 | 4 | 0 | 10 / 13 | 14 / 17 | absent | W. Aleutians, Kamchatka |

TAXONOMY

Class GYMNOLEAMATA Allman, 1856

Order CHEILOSTOMATA Busk, 1852

Suborder NEOCHEILOSTOMINA d'Hondt, 1985

Infraorder FLUSTRINA Smitt, 1868

Superfamily CALLOPOROIDEA Norman, 1903

Family Calloporidae Norman, 1903

Genus *Cauloramphus* Norman, 1903

DIAGNOSIS. Colony unilaminar, multiseriate, encrusting. Gymnocyst reduced or moderately broad; a narrow, sloping cryptocyst usually surrounds the opesia; cryptocyst tuberculate or smooth. Frontal avicularia single, paired, or multiple; with flexible joint at base, often pedunculate. Some species bud sessile (non-jointed) avicularia (fig. 9B in Grischenko et al., 2007; Fig. 2E herein), from marginal pore chambers. Circum-opesial spines present; orificial spines with a flexible joint at base; opesial spines with or without a flexible joint (Dick et al., 2009). Reproductive zooids have a reduced, vestigial kenozooidal oecium (e.g., Figs. 2C, 2F, 4D, 5C) with a median oecial pore; brooding is endozooidal (Ostrovsky et al., 2007). Zooids interconnect by tubular pore chambers (most evident in Figs. 3A, 4A) and uniporous septula (Figs. 2F, 5F).

Cauloramphus gracilis new species

(Fig. 2A–C)

ETYMOLOGY. The species name is from the Latin adjective *gracilis* (slender, thin), referring to the extremely elongate pedunculate avicularia.

MATERIAL EXAMINED (see Table 1 for station data). **HOLOTYPE:** YPM 48068, Stn. 111-26, dried colony on scallop shell; part bleached and coated for SEM. **PARATYPES:** 1) YPM 48069, Stn. 110-24, colony on rock fragment coated for SEM; 2) YPM 48070, Stn. 113-21, dried colonies on three pebbles; 3) NHM 2010.2.10.17, Stn. 110-24, dried colony on scallop shell; 4) NHM 2010.2.10.18, Stn. 113-21, colonies on rock fragment coated for SEM.

MEASUREMENTS. ZL, 0.77–1.13 (0.94 ± 0.096); ZW, 0.56–0.77 (0.65 ± 0.058); OpL, 0.56–0.76 (0.68 ± 0.054); OpW, 0.35–0.49 (0.41 ± 0.036) (n = 30, 2; YPM 48068, 48069). AvL, 0.74–0.82 (0.79 ± 0.033); AvD, 0.12–0.13 (0.12 ± 0.007) (n = 5, 1; YPM 48068).

DESCRIPTION. Colony forms irregular patches; largest observed ca. 3 × 1 cm; orange-tan in color. Zooids (Fig. 2A, B) large, closely appressed, delineated by an interzooidal furrow; gymnocyst narrow and steeply sloping around zooid; cryptocyst a narrow, smooth shelf. Basal wall not calcified. Zooids with 19–31 (mode = 25) total spines (n = 30, 2; YPM 48068, NHM 2010.2.10.17) closely arranged around mural rim, including 7–9 (mode = 8) long (up to 0.8 mm), heavy orificial spines, 10–21 (mode = 15) slightly or strongly curved opesial spines arching over the opesia, and one pair of intermediate spines between the orificial and opesial spines; intermediate spines shorter and sharper than orificial spines; longer, straighter, and more erect than opesial spines. Avicularia sparse, lacking on most zooids, single only; with an exceptionally long, thin peduncle (Fig. 2A); total length up to as long as longest distal spines; attached in position 5/6, from near base of most distal opesial spine to as far distally as base of intermediate spine; average AvL/AvD = 6.6. Kenozooidal oecium (Fig. 2C) narrow, crescent shaped, rising to a low, chevron-shaped lip at distal end of mural rim.

REMARKS. With its many spines and long-pedunculate avicularia, *C. gracilis* is similar to *C. spectabilis* Dick and Ross, 1988, described from Kodiak, Alaska; *C. multispinosus* Grischenko et al., 2007, described from Akkeshi Bay, Japan; and *C. cymbaeformis* (Hincks, 1877), a circumpolar, Arctic-boreal species. In *C. spectabilis*, total spines number 19–

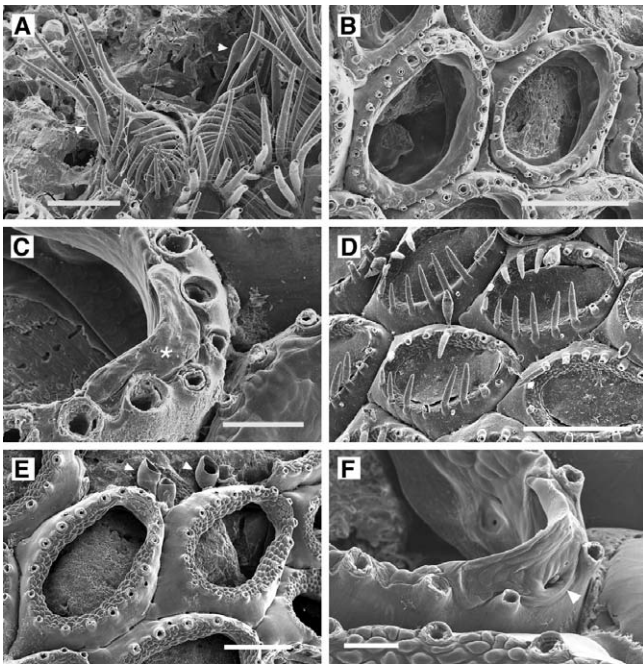

Fig. 2. (A–C) *Cauloramphus gracilis* n. sp. (A) Autozooids; arrowheads indicate long, pedunculate avicularia. Paratype 1, YPM 48069. (B) Autozooids, bleached. Holotype, YPM 48068. (C) Vestigial kenozooidal oecium at distal end of autozooid (asterisk), bleached. Holotype, YPM 48068. (D–F) *Cauloramphus ordinarius* n. sp. (D) Autozooids, before bleaching. Paratype 1, YPM 48059. (E) Autozooids, bleached; note marginal avicularia arising from pore chambers (arrowheads). (F) Vestigial kenozooidal oecium at distal end of autozooid (arrowhead), bleached. (E, F) Paratype 6, NHM 2010.2.10.13. Scale bars: 0.5 mm (A, B, D, E), 0.1 mm (C), 0.05 mm (F).

24, with eight or nine long, thick orificial spines and 12–16 arched opesial spines; the cryptocyst is smooth, and the avicularia are long-clavate; however, the zooids are markedly smaller (0.50–0.65 mm long) than in *C. gracilis* (0.77–1.13 mm); the pair of intermediate spines is lacking, and the avicularian peduncle is not nearly as long and thin (Dick and Ross, 1988). The high overall similarity between *C. spectabilis* and *C. gracilis* nonetheless suggests that they are closely related.

In *C. multispinosus*, the zooids are moderately large (0.55–0.98 mm long), and there are 20–26 total spines arranged as heavy orificial spines and thin, arching opesial spines, as in *C. gracilis*. The former differs from the latter in having a strongly granulated cryptocyst and only six orificial spines, and avicularia are apparently lacking altogether (Grischenko et al., 2007).

Cauloramphus cymbaeformis is similar to *C. gracilis* in having moderately large zooids (0.63–0.75 mm), a smooth cryptocyst, and avicularia with a long, thin peduncle. However, zooids have at most around 10 spines, all long, straight, and erect; the spines are irregularly arranged, mostly around the distal half of the mural rim; and the avicularian peduncle tends to be markedly curved (Kluge, 1975).

OCCURRENCE. We found colonies of *C. gracilis* encrusting dead scallop shells, small sponge-associated pebbles, and highly porous lava stones. It occurred at three

stations (Fig. 1) at depths of 95–355 m. The known distribution is limited to the Rat Island group, western Aleutian Islands.

Cauloramphus ordinarius new species

(Fig. 2D–F)

CAC (*Cauloramphus* Aleutian sp. C): Dick et al., 2009, 3142, fig. 1a.

ETYMOLOGY. The species name is from the Latin adjective *ordinarius* (regular, ordinary).

MATERIAL EXAMINED (see Table 1 for station data).

HOLOTYPE: YPM 48058, Stn. 110-24, parts of a single dried colony on shell fragments. **PARATYPES**, all from Stn. 113-21: 1) YPM 48059, colony fragment on pebble, bleached and coated for SEM; 2) YPM 48060, dried colony on pebble; 3) YPM 48061, two fragments of same colony on pebble, coated for SEM, one part bleached, the other unbleached; 4) NHM 2010.2.10.11, dried colony fragment on shell; 5) NHM 2010.2.10.12, dried colony fragment on shell; 6) NHM 2010.2.10.13, colony fragment on pebble, bleached and coated for SEM.

MEASUREMENTS. ZL, 0.62–0.92 (0.74 ± 0.063); ZW, 0.38–0.64 (0.51 ± 0.051); OpL, 0.33–0.55 (0.49 ± 0.045); OpW 0.23–0.38 (0.26 ± 0.030) ($n = 30, 2$; YPM 48058, 48061). AvL, 0.13–0.22 (0.17 ± 0.020); AvD, 0.05–0.08 (0.07 ± 0.006) ($n = 20, 3$; YPM 48058, YPM 48060, YPM 48061).

DESCRIPTION. Colony irregular; light yellowish tan in color; largest observed ca. 1.5 cm in maximum dimension. Zooids (Fig. 2D, E) large, angular at junctions with adjacent zooids in proximal half, semi-oval around distal half; distinct, delineated by deep interzooidal furrow. Basal wall not calcified. Gymnocyst steep, smooth, slightly convex, moderate in width, giving the zooids a slightly tumid appearance; steeper distally. Proximal to orifice, cryptocyst is a narrow, sloping, coarsely tuberculate shelf. Total spines 14–18 (mode = 16); orificial spines 4–6 (mode = 5, frequency 90%); opesial spines 9–13 (mode = 11) ($n = 30, 3$; YPM 48058, YPM 48061, NHM 2010.2.10.11). Opesial spines straight or slightly curved, angled over opesia but not reaching midline. Orificial spines as long as or shorter than opesial spines, similar in character to them but usually more erect; differentiation between orificial and opesial spines indistinct. Zooids have 0 (22%), 1 (48%), or 2 (40%; paired) avicularia ($n = 40, 2$; YPM 48058, NHM 2010.2.10.11). Avicularia (Fig. 2D) with short, thin pedicle expanding rapidly to fusiform or clavate body; as long as or shorter than the longest opesial spines on a particular zooid; attached to gymnocyst usually in position 4/5, between first and second opesial spines, at or slightly distal to middle of zooid; average AvL/AvD = 2.4. Occasional zooids were observed budding multiple tiny, sessile avicularia (Fig. 2E) from the openings of distal pore chambers at colony margin or from zooidal margins exposed by damage, very much like those reported for *C. cryptoarmatus* by Grischenko et al. (2007: p. 1075, fig. 9B). Kenozooidal oecium (Fig. 2F) a narrow crescent with a low, sharp, raised proximal lip.

REMARKS. The following set of characters distinguishes this species from other known *Cauloramphus*: large zooids; moderately broad, sloping, somewhat tumid gymnocyst; cryptocyst with very coarse tubercles; nearly straight

opesial spines not meeting in midline; orificial and opesial spines not well differentiated in form; avicularia fusiform, often attached at or slightly distal to middle of zooid, and usually not longer than the longest opesial spines.

OCCURRENCE. We found this species on dead scallop shells and sponge-associated pebbles at two stations (Fig. 1) at depths of 95 and 227 m. The known distribution is limited to the Rat Island group, western Aleutian Islands.

Cauloramphus disjunctus Canu and Bassler, 1929
(Fig. 3)

Cauloramphus disjunctus Canu and Bassler, 1929, 109, pl. 8, figs. 4–6 (fig. 5 illustrates the lectotype, USNM 7885; see Material Examined below).

Cauloramphus disjunctus: Androsova, 1958, 107, fig. 17 (in part?); Mawatari and Mawatari, 1981, 41, fig. 8; Grischenko, 1997, 163 (in part?).

MATERIAL EXAMINED. Type specimens of Canu and Bassler (1929): **LECTOTYPE**, USNM 7885; **PARALECTOTYPES**, USNM 539763, 539764, and 539765. Canu and Bassler (1929) did not designate a holotype for this species, but listed four specimens as co-types under USNM 7885. We here designate the specimen in our Fig. 3B–E as lectotype, which retains catalog number USNM 7885, and designate the three remaining specimens paralectotypes, with catalog numbers USNM 539763, 539764, and 539765. Type locality, “Cape Tsiuka, Sea of Japan; 41°36′12″N, 140°36′E”

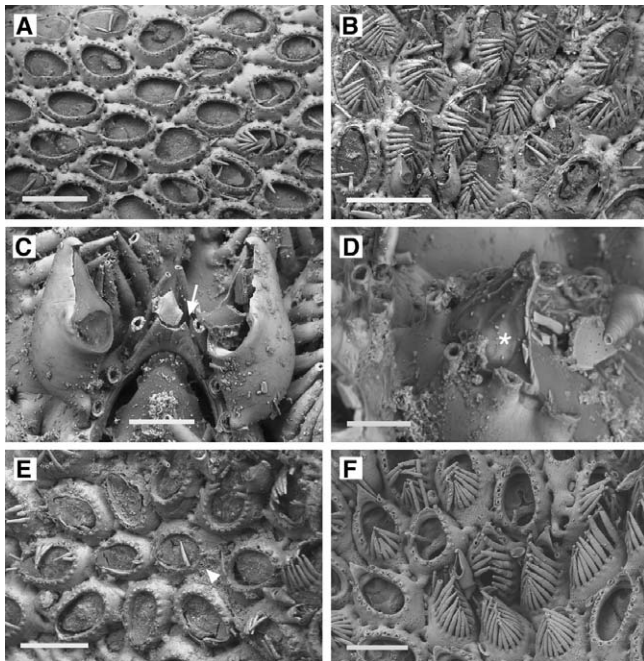

Fig. 3. *Cauloramphus disjunctus* Canu and Bassler, 1929. **(A)** Autozooids. Paralectotype, USNM 539765. **(B–E)** Lectotype, USNM 7885. **(B)** Autozooids. **(C)** Detail of raised proximal margin of oecium (broken) (arrow) and paired avicularia. **(D)** Distal surface of highly projecting kenozooidal oecium (asterisk); pore is obscured by debris. **(E)** Ancestrula (arrowhead) surrounded by seven periancestrular zooids. **(F)** Autozooids; Pleistocene fossil specimen, Lower Setana Formation, Utanai Quarry, Kuromatsunai, Hokkaido, Japan (SEM image courtesy of Paul Taylor). Scale bars: 0.5 mm (A, B), 0.1 mm (C), 0.05 mm (D), 0.25 mm (E), 0.3 mm (F).

(Canu and Bassler, 1929), which according to the coordinates is actually within Tsugaru Strait, approximately 25 km SSW of Hakodate, Hokkaido. Other material examined: fossil specimen, Pleistocene Setana Formation, Kuromatsunai, Hokkaido, Japan; coll. M. Dick, 24 Aug. 2005; deposited in NHM, London.

MEASUREMENTS. ZL, 0.45–0.63 (0.53 ± 0.050); ZW, 0.31–0.51 (0.36 ± 0.039); OpL, 0.30–0.40 (0.35 ± 0.030); OpW, 0.16–0.24 (0.19 ± 0.022) ($n = 30, 2$; USNM 539763, 539765). AvL, 0.21–0.27 (0.23 ± 0.019); AvD, 0.07–0.11 (0.09 ± 0.012) ($n = 13, 2$; USNM 7885, USNM 539764).

DESCRIPTION. Zooids (Fig. 3A, B, E, F) disjunct, interconnected by tubular chambers separated by around seven uniformly sized lacunae along each lateral margin. Basal wall not calcified. Gymnocyst broad laterally and proximally, sloping, convex. Cryptocyst a narrow, nearly vertical shelf around opesia; smooth. Three or four (mode, 4) relatively short, slender, erect orificial spines distal to orifice; one pair of long, heavy sub-erect intermediate spines lateral to orifice, and 14–20 (mode, 17) tapering, acuminate opesial spines very closely set, with little space between them, angled over the opesia and meeting in midline; total spines 19–26 (mode, 23). Avicularia (Fig. 3B, C, F) predominantly paired, attached in position 4/5, between 1st and 2nd opesial spines; peduncle short, rapidly swelling to body of avicularium; rostrum raised proximally, forming a sharp lip in proximal curvature of avicularium; average AvL/AvD = 2.6. Proximal margin of mature oecium (Fig. 3C, D) forms a raised, triangular flange, sometimes very tall and acute. Ancestrula (Fig. 3E) with oval opesia, broad gymnocyst, around 13 spines, giving rise to seven periancestrular zooids (one distally, two distolaterally, and four laterally and proximally).

REMARKS. The discovery in the Aleutians and Commander Islands of a clade containing species related to *C. disjunctus* Canu and Bassler raises the possibility that there may be additional, related species along the Asian coast. Androsova’s (1958) drawing of nominal *C. disjunctus* from the northern Sea of Japan appears to indicate some differences from the type material for *C. disjunctus*. Her illustrations show more-elongate avicularia (AvL/AvD up to ca. 4.0) that lack the proximal rostral lip and are attached just distal to the first pair of opesial spines, and the zooids are more disjunct, with longer interzooidal tubes and larger lacunae. Androsova’s drawing is rough, however, and her material needs reexamination.

Cauloramphus amphidisjunctus described herein is similar and likely closely related to *C. disjunctus* Canu and Bassler. Differences between the two are noted in Remarks under *C. amphidisjunctus*.

OCCURRENCE. This is a subtidal species distributed along both coasts of Japan from central Honshu to southern Hokkaido. Mawatari and Mawatari (1981) listed as its range as Matsushima (Sendai Bay, northeastern Honshu) to Kushiro (south-central Hokkaido) on the Pacific side, and as far south as Toyama Bay (central Honshu) on the Sea of Japan. Androsova (1958) reported nominal *C. disjunctus* from the northern Sea of Japan at depths of 36–93 m. Grischenko (1997) listed this species from depths of 5–46 m on the shelf around the Commander Islands, but his material needs reexamination in light of our discovery of *C. oshurkovi*

in the Commanders.

***Cauloramphus amphidisjunctus* new species**

(Fig. 4)

ETYMOLOGY. The species name is a combination of *disjunctus*, referring to *C. disjunctus*, and the Greek *amphi* (both sides of, apart), indicating morphological and geographical separation from *C. disjunctus*.

MATERIAL EXAMINED (see Table 1 for station data). **HOLOTYPE:** YPM 48071, Stn. 12-45, dried colony on plastic; parts coated for SEM, bleached and unbleached. **PARATYPES:** 1) YPM 48072, Stn. 116-13, colonies on fragments of skate egg case; 2) YPM 48073, Stn. 116-13, colony fragments on skate egg case, coated for SEM; 3) NHM 2010.2.10.19, Stn. 12-45, two dried colonies on plastic; 4) NHM 2010.2.10.20, Stn. 12-45, dried colony on pebble.

MEASUREMENTS. ZL, 0.51–0.74 (0.64 ± 0.055); ZW, 0.36–0.51 (0.44 ± 0.040); OpL, 0.30–0.49 (0.38 ± 0.052); OpW, 0.17–0.23 (0.20 ± 0.018); AvL, 0.26–0.35 (0.30 ± 0.024); AvD, 0.11–0.17 (0.13 ± 0.015) ($n = 30, 2$; YPM 48071, 48072).

DESCRIPTION. Zooids (Fig. 4A–C) separated by a deep furrow, connected by narrow tubular chambers separated by around seven large, irregular lacunae along each lateral margin. Basal wall not calcified. Gymnocyst broad laterally and proximally, nearly vertical. Cryptocyst a narrow, nearly vertical, shelf around opesia; smooth. Two or three short (mode, 2), slender orificial spines distal to orifice, angled distally; one pair of slightly longer, thicker, erect intermediate spines lateral to orifice, and 11–16 (mode, 13) tapering, acuminate opesial spines angled over opesia, occasionally but not usually meeting in midline, separated at base by a distance equal to or somewhat less than maximum spine diameter; total spines 15–21 (mode, 18). In older zooids, bases of intermediate and opesial spines become calcified so that spines remain after bleaching and gentle rinsing. Avicularia (Fig. 4A, B) paired, attached in position 3/4, between 1st and 2nd angled opesial spines; peduncle short, rapidly swelling to body of avicularium; rostrum usually not

raised proximally, but continuous with proximal curvature of avicularium; average AvL/AvD = 2.3. Proximal margin of mature oecium (Fig. 4D) forms a raised, triangular flange; when tall, flange is spatulate rather than very narrow and acute.

REMARKS. Compared to *C. disjunctus* (Table 2), this species has larger zooids and avicularia, though the latter have almost the same length/depth ratio; narrower tubes connecting zooids; larger lacunae that are less regular in size and spacing; and fewer orificial and opesial spines. Most avicularia lack a lip at the proximal end of the rostrum. The most striking difference is in the density of opesial spines, which are much more closely packed in *C. disjunctus* than in *C. amphidisjunctus*.

With markedly disjunct zooids and a similar overall distribution of spines, these two forms are clearly closely related and may be sibling species. We consider them to be distinct species because *C. disjunctus* in northern Japan shows a high degree of morphological continuity from the Lower Pleistocene (Fig. 3F) to the present (Fig. 3B), whereas the geographically separate Aleutian form is divergent in several quantitative and qualitative characters that, taken together, likely indicate significant genetic divergence.

OCCURRENCE. We found this species at stations 116-13 southwest of Amchitka I. and 12-45 on Stalemate Bank, at depths of 156 and 189 m, respectively. The known distribution is limited to the western Aleutian Islands.

***Cauloramphus cheliferoideus* new species**

(Fig. 5A–C)

“*Cauloramphus disjunctus* Ortmann, 1890”: Dick et al., 2009, 3143, fig. 1b. In addition to misspelling ‘Ortmann’, Dick et al. (2009) erroneously cited the original description of *C. disjunctus* as Ortmann (1890), when it is actually Canu and Bassler (1929).

ETYMOLOGY. The species name combines the Greek *chêlê* (claw), the Latin *ferre* (to bear), and the Greek suffix *-oides* (in the form of) to convey the meaning ‘as though bearing chelae, or claws’, referring to the paired avicularia appearing like paired chelae.

MATERIAL EXAMINED (see Table 1 for station data). **HOLOTYPE:** YPM 48062, Stn. 111-26, dried colony on scallop shell fragment. **PARATYPES:** 1) YPM 48063, Stn. 111-26, colony on scallop shell fragment, bleached and coated for SEM; 2) YPM 48064, Stn. 111-26, dried colony on scallop shell fragment; 3) YPM 48065, Stn. 111-26, dried colony on scallop shell fragment; 4) YPM 48066, Stn. 111-26, dried colony on polychaete tube; 5) YPM 48067, Stn. 110-24, two dried colonies on volcanic pebbles; 6) NHM 2010.2.10.14, Stn. 110-24, dried colony on scallop shell fragment; 7) NHM 2010.2.10.15, Stn. 110-24, two dried colonies on volcanic pebbles; 8) NHM 2010.2.10.16, dried colony on scallop shell. **OTHER:** Colony on shell fragment with colony of *C. ascofer*, on slide labeled “Amchitka I., C.E. O’Clair, 69-RD2-9”; we were unable to obtain exact locality and depth information for this old (probably 1969) collection number.

MEASUREMENTS. ZL, 0.47–0.64 (0.56 ± 0.049); ZW, 0.33–0.46 (0.40 ± 0.033); OpL, 0.23–0.41 (0.33 ± 0.043); OpW, 0.13–0.23 (0.19 ± 0.025) ($n = 30, 2$; YPM 48062, 48063). AvL, 0.20–0.28 (0.24 ± 0.018); AvD, 0.10–0.17 (0.13 ± 0.018) ($n = 30, 2$; YPM 48062, YPM 48064).

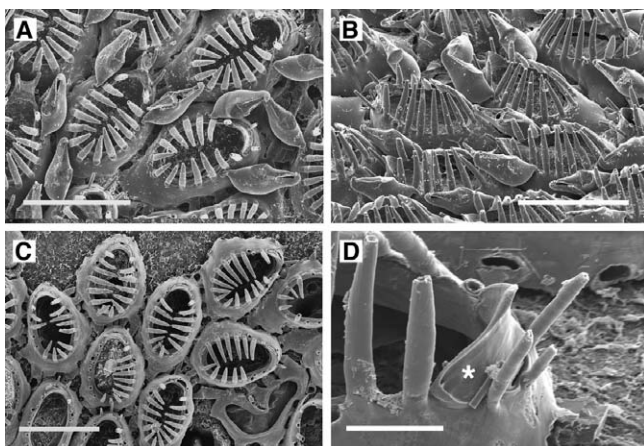

Fig. 4. *Cauloramphus amphidisjunctus* n. sp. Holotype, YPM 48071. (A, B) Autozooids and avicularia, unbleached. (C) Autozooids, bleached. (D) Distal end of bleached zooid showing kenozooidal oecium (asterisk). Scale bars: 0.5 mm (A–C), 0.05 mm (D).

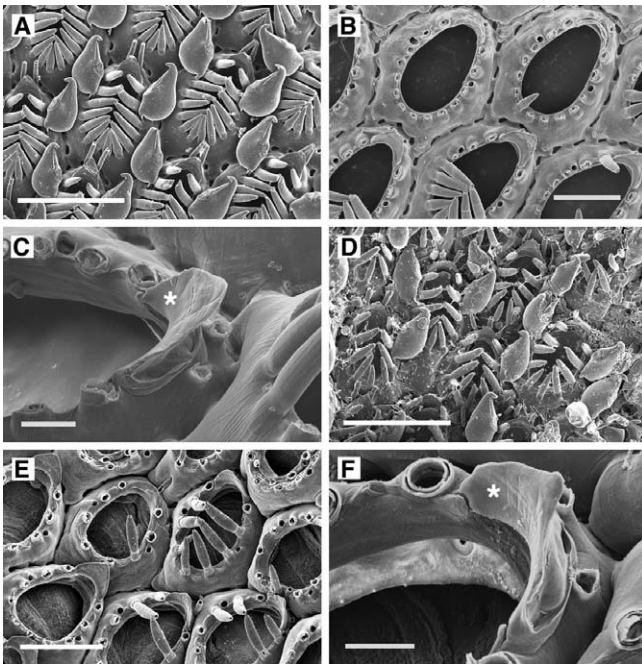

Fig. 5. (A–C) *Cauloramphus cheiliferoides* n. sp. Paratype 1, YPM 48063. (A) Autozooids, unbleached. (B) Autozooids, bleached. (C) Distal end of bleached zooid showing raised kenozooidal oecium (asterisk). (D–F) *Cauloramphus oshurkovi* n. sp. Holotype, YPM 48075. (D) Autozooids, unbleached. (E) Autozooids, bleached. (F) Distal end of bleached zooid showing kenozooidal oecium (asterisk). Scale bars: 0.5 mm (A, D), 0.25 mm (B, E), 0.05 mm (C, F).

DESCRIPTION. Colony white to light tan in color, forming small irregular or circular patches; largest observed 1 cm in diameter. Zooids (Fig. 5A, B) distinct, delineated by a conspicuous interzooidal furrow, interconnected by seven to ten tubular chambers on each side, with tiny, compressed lacunae between connections. Basal wall not calcified. Gymnocyte smooth, sloping, convex, broad proximally and laterally. Cryptocyst a smooth, narrow, nearly vertical shelf, not visible from above. Zooids have two thin orificial spines set close to one another at distal end of zooid, erect or angled distally; one pair of cylindrical, tapering intermediate spines angled over opesia, nearly meeting in midline; 10–15 opesial spines angled over opesia; and 14–19 total spines ($n = 30, 2$). Opesial spines meet in midline, forming a tight basket; most distal pair longer and thicker than the rest, slightly curved in distal direction, somewhat flattened (elliptical in cross-section). In older zooids, bases of intermediate and opesial spines become calcified so that spines remain after bleaching and gentle rinsing. Nearly all zooids have two (paired) avicularia, one on each side attached by a tiny pedicle in position 3/4, between first and second most distal opesial spines. Avicularia (Fig. 5A) large, conspicuous, about half as long as zooid, with bulbous chamber and aquiliform rostrum hooked at tip; average $AvL/AvD = 1.8$. Kenozooidal oecium (Fig. 5C) a narrow crescent around distal margin, with proximal lip greatly extended (Fig. 5A, C) as a triangular flange, up to as long as distal orificial spines.

REMARKS. Dick et al. (2009) identified this species as *C. disjunctus* due to the large, paired avicularia and some-

what disjunct zooids with small lacunae evident between them in SEM images; at that time, *C. disjunctus* was the only known species with similar characters. *Cauloramphus cheiliferoides* and *C. disjunctus* are very similar in opesia and zooid size, but differ in many other characters (Table 2), including avicularium length/depth ratio; avicularium position; and number of orificial, opesial, and total spines. In *C. cheiliferoides*, the interzooidal lacunae are more numerous, smaller, and more compressed, often almost slit-like, and the avicularia are distinctly more bulbous (lower length/depth ratio). Among species in the *C. disjunctus* clade, *C. cheiliferoides* is most similar to *C. oshurkovi*; differences between the two are discussed below in the Remarks section for the latter.

OCCURRENCE. We found this species at Stns. 110-24 and 111-26 at depths of 95 m and 355 m, respectively; we also have a specimen labeled “Amchitka I.,” without exact locality information. The species is presently known only from the Rat Island Group, western Aleutian Islands, Alaska.

Cauloramphus oshurkovi new species

(Fig. 5D–F)

MATERIAL EXAMINED. HOLOTYPE, YPM 48075, Cape Lebyazhyy, Pacific side of Mednyy Island, Commander Islands; rock face at 30 m depth; collected by SCUBA on 28 July 1992 by V. V. Oshurkov. Part of colony on shell fragment, bleached, coated for SEM; two fragments of same colony, unbleached, dried.

ETYMOLOGY. The species is named for the collector, Vladimir V. Oshurkov (1946–1994), zoologist and hydrobiologist, former head of the Laboratory of Benthic Communities, Kamchatka Institute of Ecology and Nature Management (KIENM), Petropavlovsk-Kamchatsky, Russia.

MEASUREMENTS. ZL, 0.46–0.54 (0.49 ± 0.03); ZW, 0.33–0.44 (0.39 ± 0.04); OpL, 0.23–0.33 (0.32 ± 0.01); OpW, 0.17–0.21 (0.20 ± 0.01); AvL, 0.24–0.28 (0.27 ± 0.01); AvD, 0.13–0.26 (0.16 ± 0.06) ($n = 15, 1$; YPM 48075).

DESCRIPTION. Colony light tan in color. Zooids (Fig. 5D, E) small, closely appressed, with tubular interzooidal connections and elongate lacunae barely evident in SEM images. Basal wall not calcified. Gymnocyte sloping, broadest proximally; narrower and nearly vertical laterally. Cryptocyst a smooth, moderately wide, nearly vertical rim around opesia. Zooids with two short, thin, erect spines distal to orifice; two thicker, longer intermediate spines lateral to orifice, angled slightly medially, and 6–8 straight, slightly tapering, subacute opesial spines angled over opesia, meeting in midline in some zooids and nearly so in others; most distal opesial spines longer and heavier than intermediate spines. In older zooids, bases of intermediate and opesial spines become calcified, so that spines remain after bleaching and gentle rinsing. Avicularia (Fig. 5D) bulbous: average $AvL/AvD = 1.7$. Proximal lip of mature oecium (Fig. 5E, F) moderately tall, triangular; acute or rounded.

REMARKS. Among members of the *C. disjunctus* clade, *Cauloramphus oshurkovi* is most similar to *C. cheiliferoides*. The two are quite similar in all measurements, and in the form of the avicularia and oecia (Table 2). The zooids are more closely packed in *C. oshurkovi* than in *C. cheiliferoides*, so that the short tubular connections and small lacunae evident in SEM images of bleached specimens of the latter are

scarcely evident in the former. In *C. oshurkovi*, both the two thin distal spines and the opesia spines are more widely spaced; *Cauloramphus oshurkovi* has many fewer opesia and hence total spines (mode = 11, range 10–12) than *C. cheliferooides* (mode = 15 or 16, range 14–19) (Table 2).

OCCURRENCE. This species is known only from the type locality near Mednyy Island, Commander Islands.

Cauloramphus infensus new species

(Fig. 6A–D)

MATERIAL EXAMINED (see Table 1 for station data).

HOLOTYPE: YPM 48051, Stn. 110-24, large colony on scallop shell, dried. **PARATYPES:** 1) YPM 48052, Stn. 110-24, dried colony fragment on volcanic pebble; 2) YPM 48053, Stn. 110-24, two dried colony fragments on volcanic pebbles; 3) YPM 48054, Stn. 111-26, dried colonies on scallop shell; 4) YPM 48055, Stn. 111-26, Colony on volcanic rock; 5) YPM 48056, Stn. 110-24, colony on pebble, bleached and coated for SEM; 6) YPM 48057, Stn. 110-24, colony on pebble, bleached and coated for SEM; 7) NHM 2010.2.10.6, Stn. 111-26, colony on volcanic rock; 8) NHM 2010.2.10.7, Stn. 110-24, dried colony on volcanic pebble; 9) NHM 2010.2.10.8, Stn. 110-24, dried colony on volcanic pebble; 10) NHM 2010.2.10.9, Stn. 110-24, dried colony on volcanic pebble; 11) NHM 2010.2.10.10, Stn. 110-24, colony on pebble, bleached and coated for SEM.

ETYMOLOGY. The species name is from the Latin adjective *infensus* (hostile, aggressive), referring to the

large, paired avicularia.

MEASUREMENTS. ZL, 0.49–0.74 (0.61 ± 0.057); ZW, 0.35–0.51 (0.42 ± 0.044); OpL, 0.32–0.51 (0.43 ± 0.052); OpW, 0.18–0.28 (0.24 ± 0.030); AvL, 0.37–0.51 (0.43 ± 0.031); AvD, 0.13–0.21 (0.17 ± 0.017) (n = 30, 2; YPM 48051, 48055).

DESCRIPTION. Colony tan in color; largest observed 2 × 3 cm. Zooids (Fig. 6A–C) close together, separated by a deep furrow; short interzooidal tubular connections and tiny lacunae evident only between some zooids in SEM images. Basal wall not calcified, or with non-calcified central window of variable size. Lateral and proximal gymnocyst usually narrow and nearly vertical, though some zooids have an extensive proximal gymnocyst. Cryptocyst a conspicuous sloping shelf laterally and proximally; covered with low, coarse tubercles that are elliptical in outline. Zooids have 4–7 (mode, 6) long, tapering, acute orificial spines, erect or angled slightly distally, arranged around the orifice distally and laterally; more proximal orificial spines generally as long as or longer than longest opesia spines. Intermediate spines lacking. Angled over opesia are 10–14 (mode, 12) long, straight, tapering, acute opesia spines, meeting in midline; opesia spines separated at base by a distance equal to or less than maximum spine width; not touching one another laterally. Total number of spines 15–20 (mode, 18). In older zooids, bases of the intermediate and opesia spines become calcified so that spines remain after bleaching and gentle rinsing. Avicularia (Fig. 6A) single or paired; elongate (average AvL/AvD = 2.5); approximately as long as zooid width; hooked at tip; attached in 4/5 position. Proximal lip of mature oecium (Fig. 6D) forms a short to moderately tall, triangular, often acute projection.

REMARKS. With large, often paired avicularia, *C. infensus* resembles *C. disjunctus*, *C. amphidisjunctus*, *C. cheliferooides*, *C. parvus*, and *C. oshurkovi*. It differs from these in having larger zooids than all except *C. amphidisjunctus*; longer avicularia in both absolute terms and in relation to zooid width; six long, heavy orificial spines, with no differentiation of a pair of intermediate spines; and a tuberculate rather than a smooth cryptocyst.

OCCURRENCE. We found this species only at Stations 110-24 and 111-26, at depths of 95 m and 355 m, respectively. The known distribution is confined to the Rat Island Group, western Aleutian Islands.

Cauloramphus parvus new species

(Fig. 6E, F)

MATERIAL EXAMINED (see Table 1 for station data).

HOLOTYPE: YPM 48074, Station 111-26, tiny colony on small volcanic pebble.

ETYMOLOGY. The species name is from the Latin *parvus* (small), referring to the small, precocious colony and small zooids.

MEASUREMENTS. ZL, 0.33–0.51 (0.44 ± 0.052); ZW, 0.26–0.36 (0.30 ± 0.033); OpL, 0.23–0.35 (0.29 ± 0.034); OpW, 0.12–0.18 (0.15 ± 0.019); AvL, 0.21–0.26 (0.24 ± 0.016); AvD, 0.07–0.10 (0.09 ± 0.011); (n = 15, 1; YPM 48074).

DESCRIPTION. Only one tiny colony was observed; tan in color, 2 × 3 mm. Lateral and proximal gymnocyst narrow; cryptocyst a smooth, narrow vertical rim around opesia.

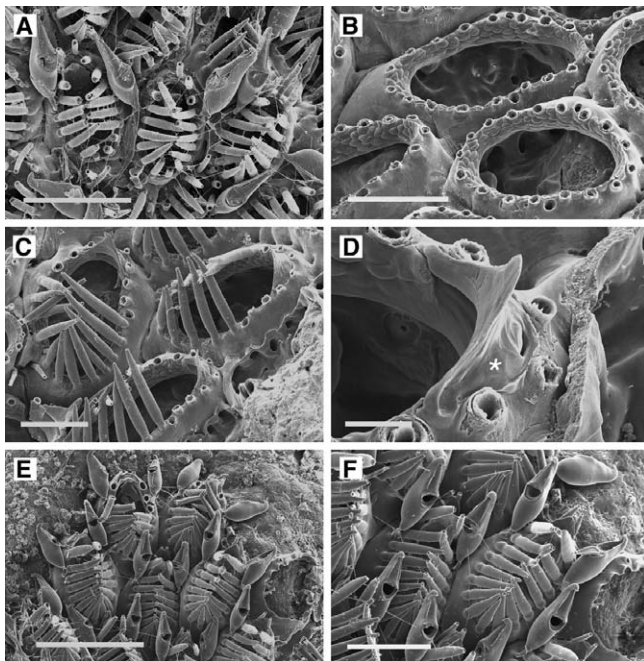

Fig. 6. (A–D) *Cauloramphus infensus* n. sp. (A, B, D) Paratype 11, NHM 2010.2.10.10, before bleaching (A) and after bleaching (B, D). (A, B) Autozooids. (C) Autozooids, bleached. Paratype 6, NHM 2010.2.10.6. (D) Distal end of bleached zooid showing kenozooidal oecium (asterisk). (E, F) *Cauloramphus parvus* n. sp. Holotype, YPM 48074. Autozooids, with (F) an enlarged view of two zooids in (E). Scale bars: 0.5 mm (A, E), 0.25 mm (B, C, F), 0.05 mm (D). Note that (A) and (E) are at the same scale.

Zooids (Fig. 6E, F) tiny, with two thin, nearly erect orificial spines at distal end; two tall, thick, straight, slightly flattened intermediate spines lateral to orifice, angled medially; and 11–16 (mode, 14) cylindrical, tapering, acuminate opesial spines angled over opesia and meeting in midline; total spines 15–20 (mode, 18). Distal pair of opesial spines very slightly curved toward orifice. Avicularia paired on most zooids, attached in position 3/4; elongate, AvL/AvD = 2.7. Proximal lip of oecium tall; rounded or acute.

REMARKS. *Cauloramphus parvus* is very similar in spine number and formula to *C. cheliferoideus* (Table 2); however, *C. parvus* has the smallest zooids of any species included in this report, while the avicularia are longer relative to zooid size and less bulbous than those of *C. cheliferoideus*. The next most similar species is *C. infensus*, which has similarly elongate avicularia, but much larger zooids and avicularia (Table 2), a much different spine formula, and a relatively wide, tuberculate cryptocyst. *Cauloramphus parvus* is a precocious breeder; the colony observed has only 46 zooids, of which at least 25% have mature oecia, starting in the third generation of zooids from the ancestrula.

OCCURRENCE. The only known locality is Station 111-26 in the Rat Island group, at a depth of 355 m.

***Cauloramphus peltatus* new species**
(Fig. 7)

ALA (Aleutian sp. A): Dick et al., 2009, 3142, fig. 1d.

MATERIAL EXAMINED (see Table 1 for station data). All material was collected at Station 113-21. HOLOTYPE: YPM 48048, dried colony on pebble. PARATYPES: 1) YPM 48049, dried colonies on two pebbles, coated for SEM; DNA voucher for GenBank EU835947; 2) YPM 48050, dried colony on pebble, coated for SEM. 3) NHM 2010.2.10.4, colonies on two pebbles, coated for SEM; 4) NHM 2010.2.10.5, dried colonies on three pebbles.

ETYMOLOGY. The species name is from the Latin adjective *peltatus* (armed with a shield).

MEASUREMENTS. ZL, 0.38–0.56 (0.49 ± 0.049); ZW, 0.28–0.44 (0.36 ± 0.037) ($n = 30, 3$; YPM 48048; YPM 48049, two colonies). AvL, 0.17–0.22 (0.19 ± 0.012); AvD, 0.06–0.10 (0.08 ± 0.010) ($n = 20, 3$; NHM 2010.2.10.5; YPM 48049, two colonies).

DESCRIPTION. Colony forms small, off-white, irregular patches; largest observed (holotype) 12×7 mm in extent; all specimens occurred on small pebbles (largest 1.8×1.5 cm; holotype) attached to the bases of sponges. Zooids (Fig. 7A, B) distinct, separated by a broad, deep furrow; closely set, with short interconnecting tubes and slit-like lacunae barely evident in SEM images. Basal wall not calcified. Proximal and lateral gymnocyst extensive; wide and moderately steep. Cryptocyst a smooth, vertical flange surrounding opesia; completely obscured by spines (costae) in intact zooids; evident only from internal view (Fig. 7C). Zooids with two short, moderately stout, erect orificial spines distal to orifice, close to midline; a pair of heavy, erect, somewhat flattened intermediate spines lateral to orifice, and 15–19 (mode, 18) flattened opesial spines, slightly curved and angled over opesia; ends of opesial spines broad. Opesial spines tightly appressed to one another, forming a frontal shield over unmodified frontal membrane. Opesial spines have lost the basal articulation, which has

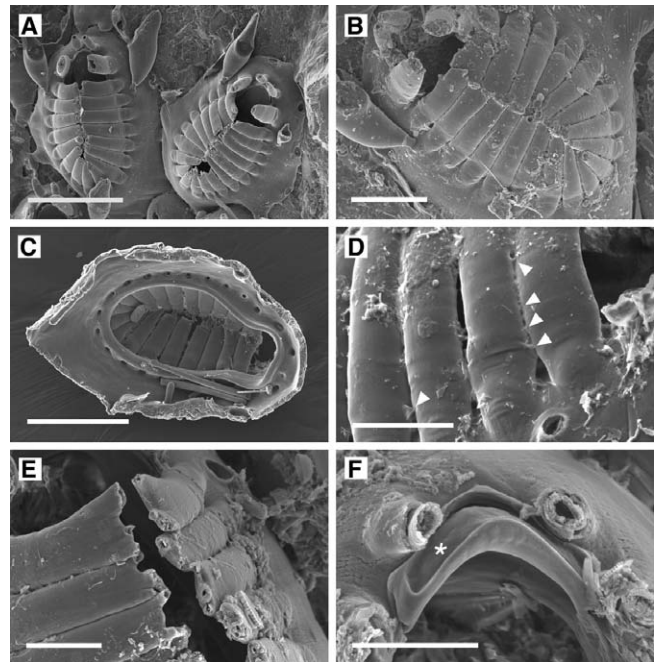

Fig. 7. *Cauloramphus peltatus* n. sp. (A–D) Paratype 1, YPM 48079. (A) Autozooids, unbleached. (B) Enlarged view of costal shield, unbleached. (C) Interior view of bleached zooid removed from paratype 1. (D) Enlargement showing basal part of four costae, with struts of calcification (arrowheads) weakly fusing them laterally (bleached). (E, F) Paratype 3, NHM 2010.2.10.4. (E) Distal ends of costae showing irregular projections that effect interlocking of the costal tips in the midline. (F) Distal end of bleached zooid showing the kenozooidal oecium (asterisk). Scale bars: 0.25 mm (A), 0.1 mm (B), 0.2 mm (C), 0.05 mm (D–F).

become calcified, and thus comprise costae, by definition (Gordon, 2000); costae are held weakly together laterally by tiny struts of calcification (Fig. 7D) and medially by terminal interlocking projections (Fig. 7E), and can be forced apart laterally and medially (Fig. 7E) with a probe. Avicularia (Fig. 7A) typically paired, attached in position 3 or 3/4, lateral to most distal (first) pair of opesial spines or on lateral gymnocyst between first and second pairs of opesial spines; elongate (average AvL/W = 2.4). Oecium (Fig. 7F) chevron shaped; proximal margin raised as low, rounded flange; distal margin with deep transverse furrow.

REMARKS. This is the only known *Cauloramphus* species having a costal shield composed of tightly appressed, weakly fused costae overlying a relatively unmodified opesia and frontal membrane.

OCCURRENCE. Presently known only from Stn. 113-21 in the Rat Island group, western Aleutian Islands, Alaska (see Table 1).

***Cauloramphus ascofer* new species**
(Fig. 8)

CLC (cribrimorph-like *Cauloramphus*): Dick et al., 2009, 3143, fig. 1e–i.

MATERIAL EXAMINED (see Table 1 for station data). HOLOTYPE: YPM 48042, Stn. 12-45, dried colony on plastic. PARATYPES: 1) YPM 48043, Stn. 111-26, two dried colonies on scallop shell; 2) YPM 48044, Stn. 113-21, dried col-

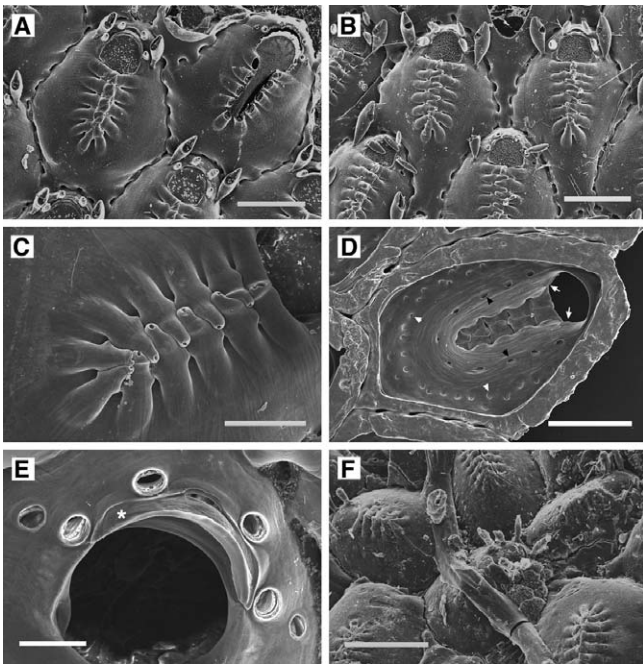

Fig. 8. *Cauloramphus ascofer* n. sp. (A, C–E) From same colony as paratype 4 (YPM 48046), most of which was destroyed during bleaching. (A) Autozooids at colony margin, unbleached; in the whole zooid at right, the costae are differentiating from the gymnocyst at the opesial margin, and the non-calcified portion of the frontal membrane covers the reduced opesia; the ascus has not yet formed. (B) Ontogenetically mature autozooids, unbleached; paratype 8, NHM 2010.2.10.3. (C) Enlarged view of costal shield. (D) Interior view of bleached zooid, showing opercular condyles (white arrows), entrances to costal lumina (black arrowheads), and parietal muscle scars (white arrowheads). (E) Enlarged view of distal end of zooid, showing kenozooidal oecium (asterisk). (F) Ancestrula (bottom center, partly covered by hydroid stolon) and periancestrular zooids; paratype 5, YMP 48047. Scale bars: 0.25 mm (A, B, D, F), 0.1 mm (C), 0.05 mm (E).

onies on three pebbles; 3) YPM 48045, Stn. 110-24, colony on pebble; 4) YPM 48046, Stn. 12-45, zooidal fragments from colony on plastic, bleached and coated for SEM to view zooidal interiors; most of colony destroyed during bleaching; DNA voucher for GenBank EU835953; 5) YPM 48047, Stn. 113-21, dried colony on scallop shell, coated for SEM; 6) NHM 2010.2.10.1, Stn. 12-45, dried colony on plastic; 7) NHM 2010.2.10.2, Stn. 12-45, dried colony on plastic; 8) NHM 2010.2.10.3, Stn. 110-24, dried colony on scallop shell. OTHER: One colony on pebble, collected by dredge by A.V. Rzhavsky (Kamchatka Institute of Ecology and Nature Management), Middle Fishery Refrigerator Trawler *Nazarovsk*, 25 Aug. 1988, Avacha Gulf, eastern Kamchatka, Stn. 118 (52°53'N, 160°08'E), 176 m depth, gravel bottom. Colony on shell fragment with colony of *C. cheliferoide*s, on slide labeled "Amchitka I., C.E. O'Clair, 69-RD2-9"; we were unable to obtain exact locality and depth information for this collection number.

ETYMOLOGY. The species name is a compound adjective from the Latin *ascus* (wine skin, sac) and *ferre* (to bear), referring to the presence of an ascus.

MEASUREMENTS. Measurements from three popula-

tions are given in Table 3.

DESCRIPTION. Colonies form irregular white patches on hard substrata, up to 5 cm or more in extent. Zooids (Fig. 8A, B) hyaline and translucent when young, chalky white when older. Boundaries between zooids distinct; short tubular connections alternating with tiny lacunae are evident between zooids in SEM images. Basal wall not calcified. Lateral and proximal gymnocyst broad, sloping, smooth. Opesial spines have lost the non-calcified basal joint, becoming costae; see Table 3 for counts of number of costae. Costae are fused to one another laterally and medially, tips interlocking in the midline, forming rigid shield over opesia (Fig. 8C); a tiny lacuna remains at base between each pair of adjacent costae. Opesia greatly reduced (Fig. 8D), completely covered by costal shield except distally, where it remains as a skeletally-defined ascophoran-type primary orifice tightly closed by a thickened operculum (Fig. 8A, B); see Table 3 for orifice measurements. Internally, there is an ascus (fig. 1h in Dick et al., 2009). Around distal margin of orifice are four or five (97% and 3%, respectively; $n = 60, 2$) short, thick, erect official spines. Most zooids (88%; $n = 60, 2$) have a pair of short, clavate avicularia (Fig. 8A, B), one on each side in position 2 or 2/3, lateral or proximalateral to proximal pair of official spines; some zooids (12%) have only a single avicularium on either side; avicularian mandible long-triangular, acute, pointing distally. Kenozooidal oecium (Fig. 8E) a narrow crescent around distal curvature of orifice; proximal margin of oecium forms a thin, slightly raised lip. Ancestrula (Fig. 8F) similar to astogenetically mature zooids, but with fewer costae in frontal shield; budding pattern is spiral, with first daughter zooid arising distally and each subsequent zooid arising from angle between the preceding zooid and ancestrula.

REMARKS. Dick et al. (2009: 3143, fig. 1e–i) briefly described and illustrated the functional morphology of this species, which has attained ascophoran-grade morphology. Externally, *Cauloramphus ascofer* is distinct from all other known species of *Cauloramphus* in having a reduced frontal shield composed of tightly fused, interlocking costae; a skeletally defined ascophoran-like orifice closed by the operculum; and an ascus.

Specimens from three geographically separate areas were found to differ in zooidal measurements and number of costae (Table 3). Compared to specimens from Stalemate Bank (Stn. 12-45) west of Attu Island, specimens from the Rat Islands (Stns. 111-26, 110-24), roughly 500 km to the east (Fig. 1), have somewhat smaller zooids; a markedly smaller orifice; a different orifice shape (slightly wider than long, rather than equal in length and width as on Stalemate Bank); more costae; and longer avicularia (Table 3). The specimen from Kamchatka is more similar to the Stalemate Bank specimens in zooid size and number of costae, but is more similar to the Rat Island specimens in having an orifice that is wider than long. These differences appear to represent geographical variation between disjunct populations rather than ecophenotypic variation related to depth, because specimens from the Rat Island group were consistent in morphology at depths of 95 and 355 m, which span the 189 m and 176 m depths of the specimens from Stalemate Bank and Kamchatka, respectively.

OCCURRENCE. We found *C. ascofer* at three stations

Table 3. Variation in measurements for *C. ascofer* among five colonies from two geographically separate areas in the western Aleutian Islands and one colony from Avacha Gulf, Kamchatka, with populations arranged from west to east (left to right), as indicated by the Longitude row. Sample sizes for the Aleutian specimens were 15 zooids per colony for measurements and 30 zooids per colony for counts. Sample sizes for the Kamchatka specimen were $n = 15$ for zooid length and width, $n = 13$ for orifice measurements, $n = 14$ for number of costae, and $n = 13$ for number of oral spines; this specimen was damaged and the avicularia had been lost.

| | KAMCHATKA | WESTERN ALEUTIAN ISLANDS | | | | |
|-------------------------|---------------|--------------------------|------------|------------------|------------------------|------------------------|
| | | Stalemate Bank | | Rat Island Group | | |
| | | Holotype | Paratype 7 | Paratype 8 | Paratype 1 Colony 1 | Paratype 1 Colony 2 |
| Station | Nazarovsk 118 | 12-45 | 12-45 | 110-24 | 111-26 | 111-26 |
| Longitude (°E) | 160.13 | 170.82 | 170.82 | 178.23 | 178.30 | 178.30 |
| Depth (m) | 176 | 189 | 189 | 95 | 355 | 355 |
| Zooid length (mm) | | | | | | |
| mean | 0.73 | 0.72 | 0.69 | 0.60 | 0.61 | 0.64 |
| range | 0.62–0.84 | 0.69–0.77 | 0.64–0.77 | 0.54–0.69 | 0.51–0.74 | 0.51–0.71 |
| Zooid width (mm) | | | | | | |
| mean | 0.53 | 0.49 | 0.49 | 0.45 | 0.41 | 0.44 |
| range | 0.48–0.59 | 0.36–0.54 | 0.44–0.56 | 0.41–0.56 | 0.35–0.44 | 0.33–0.51 |
| Orifice length (mm) | | | | | | |
| mean | 0.11 | 0.13 | 0.13 | 0.10 | 0.10 | 0.10 |
| range | 0.09–0.13 | 0.12–0.13 | 0.12–0.14 | 0.10–0.12 | 0.09–0.12 | 0.09–0.12 |
| Orifice width (mm) | | | | | | |
| mean | 0.14 | 0.13 | 0.13 | 0.12 | 0.11 | 0.12 |
| range | 0.12–0.15 | 0.13–0.14 | 0.12–0.14 | 0.10–0.13 | 0.08–0.12 | 0.10–0.13 |
| Orifice W/L ratio | 1.27 | 1.00 | 1.00 | 1.20 | 1.10 | 1.20 |
| Number of costae | | | | | | |
| mode (%) | 9 (64%) | 10 (53%) | 10 (47%) | 13 (43%) | 13 (45%) | 14 (37%) |
| range | 8–11 | 8–11 | 8–12 | 12–14 | 11–15 | 11–15 |
| No. of oral spines | | | | | | |
| mode (%) | 4 | 4 (93%) | 4 | 4 | 4 (97%) | 4 |
| range | 4 | 4 or 5 | 4 | 4 | 4 or 5 | 4 |
| Avicularium length (mm) | | | | | | |
| mean | – | 0.14 | 0.14 | 0.16 | 0.17 | 0.16 |
| range | – | 0.13–0.15 | 0.12–0.16 | 0.14–0.18 | 0.13–0.20 | 0.14–0.18 |
| Paired avicularia | – | 80% | 80% | 100% | 100% | 80% |

near the center of the Rat Island group (~178°E), at one station on Stalemate Bank to the west (~171°E) (Fig. 1), and in Avacha Gulf, eastern Kamchatka; we also have a specimen labeled “Amchitka I.,” without exact locality information. The known range is the western Aleutian Islands and Avacha Gulf, Kamchatka.

GENERAL RESULTS AND DISCUSSION

Diversity and distribution of the Aleutian *Cauloramphus* species

Eight species of *Cauloramphus* were detected in the sampling area (Fig. 1), which extended along the Aleutian shelf from south of Amchitka Island to Stalemate Bank west of Attu Island. Although bryozoans were collected at 40 sampling stations, specimens of *Cauloramphus* were found at only five stations: three relatively close together in the Rat Island group, one roughly 60 km to the southeast near Amchitka I., and one far to the west on Stalemate Bank (Fig. 1; Table 1).

This seemingly disjunct sampling distribution is almost certainly an effect of the habitats sampled and sample sizes, rather than reflecting the actual distributions or abundances

of the species involved. The samples from Stations 110-24, 111-26, and 113-21 in the Rat Island group were among the largest taken; two of them (110-24 and 111-26) comprised large numbers of dead scallop shells, with one (110-24) also containing many highly porous volcanic stones; both the shells and stones were encrusted by a diversity of *Cauloramphus* species (four or five species at each of these two stations). The sample from Station 113-21 was also exceptionally large and comprised pebbles attached to sponges; these pebbles likewise contained a high diversity (five species) of *Cauloramphus*. In all, eight *Cauloramphus* species were detected in the Rat Island group (islands between Amchitka Pass and Kiska Pass). The two *Cauloramphus* species found at Station 12-45 on Stalemate Bank were both encrusting heavy plastic panels lining the entrance to an abandoned crab pot. *Cauloramphus amphidisjunctus* was found only on smooth, flat substrates: the plastic panels at Station 12-45 and skate egg cases at Station 116-13.

The otter trawl used for sampling was intended to sample near-bottom fishes rather than sessile benthic animals, and only occasionally and haphazardly touched the bottom due to irregular topology. Dedicated bottom trawling in shelly and rocky habitats would likely find all eight of the *Cauloramphus* species over much broader geographical and vertical (Fig. 9) ranges than those detected in this study.

Phylogeny of the *C. disjunctus* clade

Dick et al. (2009) previously reported one of the Aleutian species described herein (*C. cheliferooides*) as *C. disjunctus*. At the time, *C. disjunctus* was the only *Cauloramphus* known with hypertrophied, paired avicularia, a frontal basket of closely set spines, and disjunct zooids. *Cauloramphus cheliferooides* is similar in these characters, but differs from *C. disjunctus* in total spine number; number of orificial spines; length/width ratio, form, and point of attachment of the avicularia; and degree of separation of zooids (Table 2).

This study has identified a clade containing a number of species with similarities to *C. disjunctus*. A synapomorphy for this clade is the presence of hypertrophied, usually paired avicularia, although *C. ascofer* lacks this character. The cryptocyst in most of the species is smooth, but that in

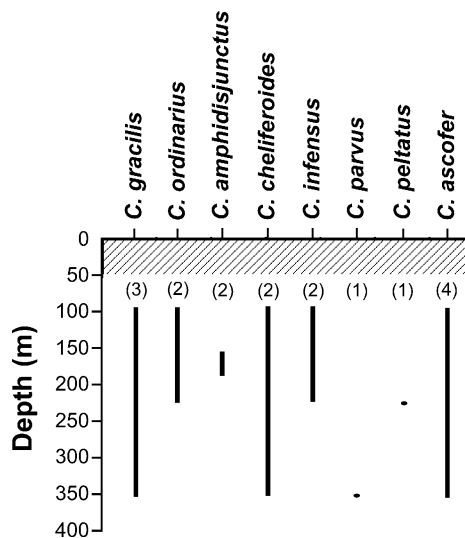

Fig. 9. Summary of known depth ranges of Aleutian *Cauloramphus* species, inferred from limited sampling data. The number in parentheses above each bar indicates the number of stations at which a species was detected. The hatched area indicates that no sampling was conducted between 0 and 50 m depth.

C. infensus is tuberculate. Only two of the species, *C. disjunctus* (Figs. 3A, 4A) and *C. amphidisjunctus* (Fig. 4B, C) have overtly disjunct zooids with obvious tubular connections and relatively conspicuous interzooidal lacunae; the other species exhibit short tubular connections and small lacunae.

Dick et al. (2009) presented a COI molecular phylogeny that included a clade comprising *C. ordinarius* (“CAC”) and a sister group containing *C. cheliferoideus* (“DIS”), *C. peltatus* (“ALA”), and *C. ascofer* (“CLC”). Nodal support for both this clade and internal nodes was weak, except for the sister-group relationship between *C. peltatus* and *C. ascofer*. Despite the lack of nodal support, the topology made sense, as among all species included in the analysis, *C. cheliferoideus* and *C. peltatus* uniquely had hypertrophied avicularia in common, and *C. peltatus* and *C. ascofer* uniquely had a tight costal shield in common. In addition, a synapomorphy for this clade was calcified opesial spine joints in ontogenetically mature zooids. Alternative optimal topologies required two independent evolutionary events involving calcification of these spine joints, or a gain and a loss (Dick et al., 2009).

In Fig. 10, we present a tree representing a hypothesis of phylogenetic relationships for the eight species in the *C. disjunctus* clade. This hypothesis retains the topology of clade F, fig. 2 in Dick et al. (2009), indicated with a thick line in our Fig. 10. *Cauloramphus ordinarius* exhibits a suite of plesiomorphic characters common to many stereotypical *Cauloramphus* species, including only cuticular (flexible) spine joints, a tuberculate cryptocyst, no differentiation of intermediate spines, and more than two orificial spines. All species in the *C. disjunctus* clade (clade A, Fig. 10) show calcification of the opesial spine bases in ontogenetically mature zooids. This character can be observed as a tendency for zooids to retain the opesial spines after bleaching and gentle rinsing, or (in the case of *C. disjunctus*) by retention of the opesial spines in fossilized specimens (Fig. 3F).

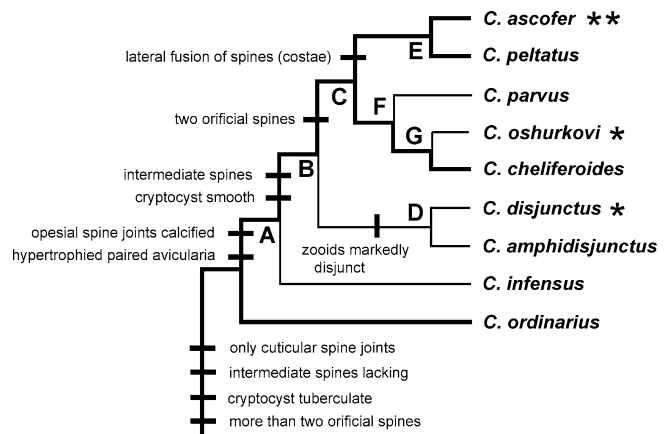

Fig. 10. Phylogenetic hypothesis for the *Cauloramphus disjunctus* clade in the northwestern Pacific. The backbone topology (branches indicated by thicker lines) is the COI tree presented by Dick et al. (2009). Taxa for which no molecular data were available (branches indicated by thinner lines) were added to the tree on the basis of morphological synapomorphies, indicated by labeled perpendicular bars. Autapomorphic characters (not indicated) distinguish between or among species within each of clades D, E, and F. Two of the species (single asterisks) have been documented only along the Asian coast; *C. ascofer* (double asterisks) has been detected both in the western Aleutians and on the Asian side.

Spine retention in bleached specimens is evident in Fig. 4C (*C. amphidisjunctus*), Fig. 5B (*C. cheliferoideus*), Fig. 5E (*C. oshurkovi*), Fig. 6C (*C. infensus*), Fig. 7C (*C. peltatus*), and Fig. 8D (*C. ascofer*); *C. parvus* and *C. disjunctus* were not subjected to bleaching.

Within clade A (Fig. 10), *C. infensus* is basal, retaining the plesiomorphic characters of a tuberculate cryptocyst, lack of well-differentiated intermediate spines, and more than two orificial spines; members of Clade B (Fig. 10) have intermediate spines and a smooth cryptocyst. Within Clade B, species in Clade D (*C. disjunctus* and *C. amphidisjunctus*) are united by the synapomorphy of markedly disjunct zooids. Most species in Clade C share the character of two orificial spines (the presence of two orificial spines equally parsimoniously supports clades A and C as a synapomorphy, with two subsequent autapomorphic changes in orificial spine number in either case). Species in Clade E (*C. ascofer* + *C. peltatus*) are united in having a tight costal shield, and molecular data strongly supported this clade (Dick et al., 2009). Similarity in all characters except spine number supports Clade G (*C. oshurkovi* + *C. cheliferoideus*). Although *C. parvus* is shown in Fig. 10 as the sister group to Clade G within Clade C, it could as well be the sister group to (Clade E + Clade G).

Cauloramphus ascofer shows several autapomorphies distinguishing it from *C. peltatus* and other members of Clade C. These include having four orificial spines, loss of intermediate spines, reduction in avicularium size, and a distal shift in the position of the avicularia, from the 3/4 to the 1/2 position. Achieving a fused costal shield and ascophoran-grade morphology apparently freed *C. ascofer* from whatever selective forces maintained the set of characters common to the other species.

Speciation and dispersal

Dick (2008) detected high species diversity in the bryozoan genus *Monoporella* in the western Aleutian Islands and noted that this diversity could have arisen through a local species radiation. The *C. disjunctus* clade shows a similar pattern, with a diverse group of closely related species in the western Aleutians, but apparently with markedly lower diversity on the Asian side. For the two genera combined, apparent endemism in the western Aleutians is 80% (12 of the 15 new species described by Dick [2008] and in this study). That two distantly related genera show similarly high apparent endemism in the western Aleutians leads us to speculate that the deep benthic bryozoans in this region have experienced high rates of speciation.

The western Aleutians have several characteristics that should be conducive to the isolation and divergence of populations, leading to allopatric speciation. This region has long been isolated from Asia by Near Strait and from mainland Alaska by distance (Gates et al., 1954; Thorson and Hamilton, 1986); the Aleutian passes comprise putative dispersal barriers for deep benthic animals (Dick, 2008); and there is (and has long been) considerable variation in environment along the archipelago (Hunt and Stabeno, 2005). We interpret the two geographically separate, morphologically distinct populations of *C. ascofer* in the western Aleutians as incipient species, and as evidence of ongoing allopatric speciation.

The tree in Fig. 10 indicates two separate sister-species pairs (*C. oshurkovi* and *C. cheliferooides*; *C. disjunctus* and *C. amphidisjunctus*) with one member each on the Asian and Aleutian sides. The tree suggests that the population ancestral to *C. oshurkovi* and *C. cheliferooides* dispersed from the Aleutians to Asia, as *C. oshurkovi* is embedded in clade F, with the other two species in the clade restricted to the Aleutians. The polarity of dispersal is ambiguous for *C. disjunctus* and *C. amphidisjunctus*, but the basal member (*C. infensus*) and over half the other species in clade A are restricted to the Aleutians, favoring dispersal from the Aleutians to Asia for the population ancestral to clade D. *Cauloramphus ascofer* has populations on both the Aleutian and Asian sides. The sister-group relationship between *C. ascofer* and *C. peltatus* (the latter known only from the Aleutians) suggests that the common ancestor of these two species was distributed in the Aleutians, and that *C. ascofer* originated in the Aleutians and dispersed to Asia. The Stalemate Bank population is more similar in morphology to the Asian population than is the Rat Island population farther eastward; this makes sense, as the Stalemate Bank population is at the western end of the Aleutian Archipelago and is the likely source population for dispersal to Asia.

These conclusions depend 1) on the accuracy of the topology in Fig. 10, and 2) whether the species apparently endemic to the Aleutians are actually endemics, or simply through lack of sufficient sampling effort have not yet been detected on the Asian side. The conclusions are thus tentative, and we consider them to represent hypotheses that can be tested, e.g., by testing the tree topology with additional DNA data; reexamining specimens from the Asian side that were previously identified as *C. disjunctus*; and conducting additional sampling on the Asian side.

On the classification of the cribrimorph *Cauloramphus* species

In a morphology-based classification, and in the absence of other definitive characters, the costal shields of *C. peltatus* and *C. ascofer* would warrant taxonomic placement of these species in Cribriliniidae (Infraorder Ascophorina, Superfamily Cribrilinoidea) rather than in Calloporidae (Infraorder Flustrina, Superfamily Calloporoidea). Fortunately, *Cauloramphus* is an unusually well defined, polythetic (Boardman et al., 1969) genus in Calloporidae, uniquely delineated by a suite of characters including circum-opesial spines, uniporous septula, basally jointed avicularia, and vestigial kenozooidal oecia. *Cauloramphus ascofer* and *C. peltatus* are clearly allied with this genus, but are so divergent in appearance from other *Cauloramphus* species and indeed from one another (they represent two morphological grades distinct from stereotypical anascan-grade *Cauloramphus* species), that without molecular phylogenetic data, morphology-based taxonomic practice would have warranted either 1) the classification of each in a separate, monospecific genus related to *Cauloramphus*, or 2) subdivision of *Cauloramphus* into several subgenera to accommodate the observed morphological disparity.

A limited molecular phylogeny (Dick et al., 2009) demonstrated that *C. ascofer* and *C. peltatus* are simply highly derived sister species well embedded in a clade comprising *Cauloramphus*. There is thus no logical justification for erecting new genus- or subgenus-level taxa to accommodate either or both of these species. *Cauloramphus* provides a case in point underscoring the need for increased efforts to reconstruct cheilostome phylogeny with DNA sequences, not only at higher levels but also at the levels of genus and family. The current cheilostome classification includes many monospecific genera. For example, the database *Indexes to Bryozoan Taxa* (<http://www.bryozoa.net/indexes.html>; accessed January 2010) lists 90 Recent and fossil genera in Family Calloporidae, among which 35 (39%) are monospecific (13 Recent genera, 14.4%; 22 genera known only as fossils, 24.4%). Many of these orphan species might, like the cribrimorph *Cauloramphus* species, represent highly morphologically divergent representatives of more speciose genera.

ACKNOWLEDGMENTS

We thank Yoshinobu Nodasaka for making available SEM facilities, Paul Taylor for SEM images of fossil *C. disjunctus*, and Dennis Gordon for reviewing the manuscript. This study was supported in part by the COE Program 'Neo-Science of Natural History' funded by MEXT, Japan, and by a Grant-in-Aid (KAKENHI C 17570070) from MEXT to M.H.D. and S.F.M. The Alaska Fisheries Science Center supported collecting in the Aleutians.

REFERENCES

- Allman GJ (1856) A Monograph of the Freshwater Polyzoa, Including All the Known Species, both British and Foreign. The Ray Society, London
- Androsova EI (1958) Bryozoa of the order Cheilostomata from the northern part of the Sea of Japan. Issledovaniya Dal'nevostochnykh Morei SSSR 5: 90–204 (in Russian)
- Boardman RC, Cheatham AH, Cook PL (1969) Intracolony variation and the genus concept in Bryozoa. Proc N Am Paleont Conv 1969C: 294–320

- Busk G (1852) An account of the Polyzoa, and sertularian zoophytes, collected in the voyage of the Rattlesnake, on the coasts of Australia and the Louisiade Archipelago. In "Narrative of the Voyage of the H.M.S. Rattlesnake, Vol 1" Ed by J MacGillivray, T & W Boone, London, pp 343–402
- Canu F, Bassler RS (1928) Fossil and Recent Bryozoa of the Gulf of Mexico region. US Natl Mus Proc 72: 1–199
- Canu F, Bassler RS (1929) Bryozoa of the Philippine region. US Natl Mus Bull 100(9): i–xi, 1–685, Plates 1–94
- Canu F, Bassler RS (1930) The bryozoan fauna of the Galapagos Islands. US Natl Mus Proc 76: 1–78
- d'Hondt J-L (1985) Contribution à la systématique des Bryozoaires Eurystomes. Apports récents et nouvelles propositions. Ann Sci Nat Zool Paris (Ser 13) 7: 1–12
- Dick MH (2008) Unexpectedly high diversity of *Monoporella* (Bryozoa: Cheilostomata) in the Aleutian Islands, Alaska: taxonomy and distribution of six new species. Zool Sci 25: 36–52
- Dick MH, Ross JRP (1988) Intertidal Bryozoa (Cheilostomata) of the Kodiak vicinity, Alaska. Cent Pac Northwest Stud Occ Pap 23: 1–133
- Dick MH, Lidgard S, Gordon DP, Mawatari SF (2009) The origin of ascophoran bryozoans was historically contingent but likely. Proc R Soc B 276: 3141–3148
- Gates O, Fraser GD, Snyder GL (1954) Preliminary report on the geology of the Aleutian Islands. Science 119: 446–447
- Gordon D (2000) Towards a phylogeny of the cheilostomes - morphological models of frontal wall/shield evolution. In "Proceedings of the 11th International Bryozoology Association Conference" Ed by A Herrera Cubilla, JBC Jackson, Smithsonian Tropical Research Institute, Balboa, pp 17–37
- Grischenko AV (1997) Bryozoans (Ctenostomida, Cheilostomida) of the Commander Islands shelf zone. In "Benthic Flora and Fauna of the Shelf Zone of the Commander Islands" Ed by AV Rzhavsky, Dalnauka Press, Vladivostok, pp 153–192 (in Russian)
- Grischenko AV, Dick MH, Mawatari SF (2007) Diversity and taxonomy of intertidal Bryozoa (Cheilostomata) at Akkeshi Bay, Hokkaido, Japan. J Nat Hist 41: 1047–1161
- Hincks T (1877) On some Polyzoa from Iceland (Greenland) and Labrador. Ann Mag Nat Hist (Ser 4) 19: 97–112
- Hunt GL Jr, Stabeno PJ (2005) Oceanography and ecology of the Aleutian archipelago: spatial and temporal variation. Fish Oceanogr 14 (Suppl 1): 292–306
- Kluge GA (1975) Bryozoa of the Northern Seas of the USSR. Amerind Publishing, New Delhi (English translation of 1962 Russian volume)
- Mawatari S, Mawatari SF (1981) Studies on Japanese anascan Bryozoa 6. Division Malacostega (4). Bull Lib Arts Sci Course Sch Med Nihon Univ 9: 23–61
- Norman AM (1903) Notes on the natural history of East Finmark — Polyzoa. Ann Mag Nat Hist (Ser 7) 11: 567–598
- Ortmann A (1890) Die Japanische Bryozoenfauna. (Bericht über die von Herrn Dr. L. Döderlein in Jahre 1880–81 gemachten Sammlungen). Arch Naturgesch 56: 1–74, pls 1–4
- Ostrovsky AN, Dick MH, Mawatari SF (2007) The internal-brooding apparatus in the bryozoan genus *Cauloramphus* (Cheilostomata: Calloporidae) and its inferred homology to ovicells. Zool Sci 24: 1187–1196
- Smitt FA (1868) Bryozoa marina in regionibus arcticis et borealibus viventia recensuit. Ofvers K Vetenskapsakad Forh Stockholm 24: 443–487
- Thorson RM, Hamilton TD (1986) Glacial geology of the Aleutian Islands based on the contributions of Robert F. Black. In "Glaciation in Alaska: The Geologic Record" Ed by KM Hamilton, KM Reed, RM Thorson, Alaska Geological Society, Anchorage, pp 171–191

(Received April 2, 2010 / Accepted July 21, 2010)