



Title	Quantum phase gate for photonic qubits using only beam splitters and postselection
Author(s)	Hofmann, Holger F.; Takeuchi, Shigeki; 竹内, 繁樹
Citation	Physical Review A, 66, 024308 https://doi.org/10.1103/PhysRevA.66.024308
Issue Date	2002-08-08
Doc URL	https://hdl.handle.net/2115/5559
Rights	Copyright © 2002 American Physical Society
Type	journal article
File Information	PRA_66_024308(2002)-CN0T.pdf



Quantum phase gate for photonic qubits using only beam splitters and postselection

Holger F. Hofmann and Shigeki Takeuchi

CREST, Japan Science and Technology Corporation (JST), Research Institute for Electronic Science, Hokkaido University, Kita-12 Nishi-6, Kita-ku, Sapporo 060-0812, Japan

(Received 18 November 2001; published 8 August 2002)

We show that a beam splitter of reflectivity one-third can be used to realize a quantum phase gate operation if only the outputs conserving the number of photons on each side are postselected.

DOI: 10.1103/PhysRevA.66.024308

PACS number(s): 03.67.Lx, 42.50.-p

The main difficulty in realizing quantum computation and quantum-information processing for single photon qubits is the optical implementation of controlled interactions between individual qubits. A deterministic interaction between separate photons would require the ability to apply strong nonlinearities during well-defined time intervals [1]. At present, there are still many technological difficulties preventing the realization of such reliable quantum gates for photonic qubits. Recently, however, it has been shown that optical nonlinearities are not necessary for photonic qubit operation if reliable single photon sources and single photon detectors are available [2]. The desired interaction between photonic qubits can also be realized by postselection. In particular, quantum phase gates and quantum control-not gates have been proposed, using additional input ports for single photons and additional output ports for postselection [2,3]. In particular, the postselection condition for a successful gate operation requires that the number of photons detected in the postselection ports is equal to the number previously added to the system. It is then possible to predict the success of the operation without further measurements on the output ports. In principle, quantum feedback and teleportation could then be used to realize a scalable optical quantum computer. However, the technological difficulties associated with the requirements of single photon sources and fast feedback are such that a realization of networks using these quantum gates is unlikely in the near future. In this Brief Report we show that a quantum phase gate operation can also be achieved using only beam splitters if postselection in the output port is permitted. Additional single photon inputs are not necessary, since the effective nonlinearity can be realized by the direct interaction of the photonic qubits at the beam splitter. While the operation of such a random gate cannot be confirmed without measuring the output, the fact that single photon sources are not necessary and that higher efficiency can be achieved with fewer optical elements should make this proposal an attractive alternative in the experimental realization of networks processing multiple photonic qubits.

The starting point for all linear optics manipulations of single photon qubits is the unitary operation \hat{U}_R of a beam splitter of reflectivity R on the two mode input. In the following, we consider only the four-dimensional Hilbert space associated with zero or one photon in each input mode. The unitary operation \hat{U}_R is then characterized by

$$\begin{aligned}\hat{U}_R|0;0\rangle &= |0;0\rangle, \\ \hat{U}_R|0;1\rangle &= \sqrt{R}|0;1\rangle - i\sqrt{1-R}|1;0\rangle, \\ \hat{U}_R|1;0\rangle &= \sqrt{R}|1;0\rangle - i\sqrt{1-R}|0;1\rangle, \\ \hat{U}_R|1;1\rangle &= (2R-1)|1;1\rangle - i\sqrt{2R(1-R)}(|2;0\rangle + |0;2\rangle).\end{aligned}\tag{1}$$

Note that the assignment of phases is somewhat arbitrary. For convenience, we have chosen the phases so that the reflected fields have the same phase as the input fields. It is now possible to distinguish photon number conserving components of the output from components with a changed photon number distribution in the output. The components describing photon number conservation are given by the diagonal elements of the unitary transformation,

$$\begin{aligned}\langle 0;0|\hat{U}_R|0;0\rangle &= 1, \\ \langle 0;1|\hat{U}_R|0;1\rangle &= \sqrt{R}, \\ \langle 1;0|\hat{U}_R|1;0\rangle &= \sqrt{R}, \\ \langle 1;1|\hat{U}_R|1;1\rangle &= 2R-1.\end{aligned}\tag{2}$$

The two photon term is an expression of the destructive interference between two photon reflection and photon exchange by two photon transmission. This interference originates from the bosonic nature of photons and causes the preference of two photons in one mode over two photons in separate modes known as photon bunching. In order to realize a quantum phase gate, this interference may be applied to create a phase change in the two photon case. Specifically, the two photon term of beam splitters with $R < 1/2$ is dominated by the negative amplitude of mutual photon transmission, causing a phase change of π with respect to the case of mutual reflection dominating at $R > 1/2$. Since photon number conservation requires reflection for both single photon inputs, postselecting only those cases where the output photon number equals the input photon number ensures that the phase shift associated with photon transmission only occurs for the two photon input. Postselection thus converts beam splitters with $R < 1/2$ into natural phase gate elements. The only problem remaining is that the postselection also

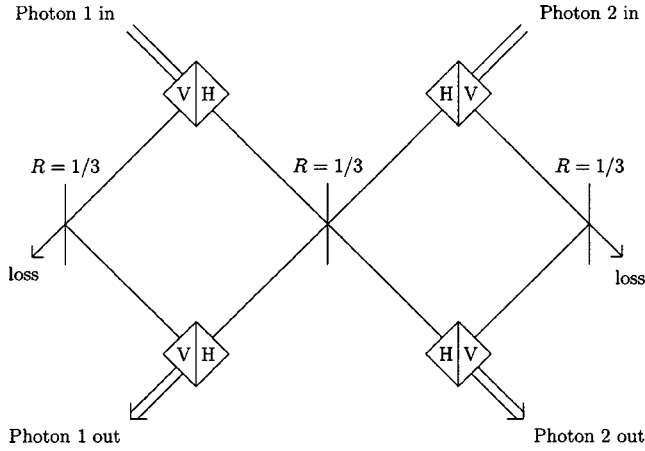

FIG. 1. Schematic setup of the postselected quantum phase gate. Vertical lines represent beam splitters of reflectivity $1/3$. Boxes represent polarization beam splitters transmitting horizontally polarized light and reflecting vertically polarized light.

changes the amplitudes associated with each input component, indicating different probabilities of success for different inputs.

In order to compensate the imbalance between the zero, one, and two photon inputs, the reduction in amplitude should correspond to linear photon losses. In other words, the two photon amplitude of $|2R - 1|$ should be equal to the square of the one photon amplitudes $|\sqrt{R}|$. This condition is fulfilled for beam splitters with one-third reflectivity. The postselected transformation at the beam splitter now reads

$$\begin{aligned}
 \langle 0;0|\hat{U}_{1/3}|0;0\rangle &= 1, \\
 \langle 0;1|\hat{U}_{1/3}|0;1\rangle &= \sqrt{1/3}, \\
 \langle 1;0|\hat{U}_{1/3}|1;0\rangle &= \sqrt{1/3}, \\
 \langle 1;1|\hat{U}_{1/3}|1;1\rangle &= -1/3.
 \end{aligned} \tag{3}$$

This operation is equal to a nonlinear phase shift of $\pi/2$ for the two photon case and a loss of two-thirds of the input photons. It is then possible to construct a phase gate for photonic qubits by applying this operation, e.g., to the horizontally (H) polarized components of the qubits, while balancing the losses by also attenuating the vertically (V) polarized components to $1/3$ of their input photon number. Figure 1 shows the complete postselected phase gate setup. If there is exactly one photon of arbitrary polarization in each input port, and if there is exactly one photon of any arbitrary polarization in each output port, this simple setup is described by the quantum phase gate operation \hat{S}_{QPG} with

$$\begin{aligned}
 \hat{S}_{\text{QPG}}|V;V\rangle &= \frac{1}{3}|V;V\rangle, \\
 \hat{S}_{\text{QPG}}|V;H\rangle &= \frac{1}{3}|V;H\rangle,
 \end{aligned} \tag{4}$$

$$\hat{S}_{\text{QPG}}|H;V\rangle = \frac{1}{3}|H;V\rangle,$$

$$\hat{S}_{\text{QPG}}|H;H\rangle = -\frac{1}{3}|H;H\rangle.$$

The application as a quantum controlled-NOT is also straightforward. Either the polarization of one input port is rotated by $\pi/4$ or the coding is defined separately in port one and port two, such that

$$\begin{aligned}
 |0\rangle_1 &= |V\rangle_1, & |0\rangle_2 &= (|V\rangle_2 + |H\rangle_2), \\
 |1\rangle_1 &= |H\rangle_1, & |1\rangle_2 &= (|V\rangle_2 - |H\rangle_2).
 \end{aligned} \tag{5}$$

In terms of the quantum bit states defined by this encoding, the operation of the same setup then reads

$$\begin{aligned}
 \hat{S}_{\text{QPG}}|00\rangle &= \frac{1}{3}|00\rangle, \\
 \hat{S}_{\text{QPG}}|01\rangle &= \frac{1}{3}|01\rangle, \\
 \hat{S}_{\text{QPG}}|10\rangle &= \frac{1}{3}|11\rangle, \\
 \hat{S}_{\text{QPG}}|11\rangle &= \frac{1}{3}|10\rangle.
 \end{aligned} \tag{6}$$

In all cases, the attenuation factor of $1/3$ indicates an efficiency of $1/9$ for the postselected gate operation. Note that this compares somewhat favorably with the efficiency of $1/16$ obtained in previous proposals [2,3]. However, the main problem of our simplified quantum gate is not so much the efficiency itself, but the difficulty of determining the postselection condition. As opposed to the previous proposals, the setup discussed here requires postselection in the output ports themselves. Some consideration should therefore be given to the kind of errors and to the possible strategies of error identification.

In principle, two types of errors should be distinguished: photon bunching errors where both input photons are found in the same output port, and photon loss errors where one or both photons do not reach the output ports at all. The setup shows that photon loss errors are only possible for the V -polarized components. The chances for photon losses are $8/9$ for the $|V;V\rangle$ component, $2/3$ for the $|V;H\rangle$ and $|H;V\rangle$ components, and zero for the $|H;H\rangle$ component. Photon losses can be detected by high efficiency photon detectors [4] placed in the respective output ports of the beam splitters inducing the losses. On the other hand, bunching errors are caused by the H -polarized components. For the $|H;H\rangle$ component, the probability of photon bunching at the central beam splitter is $8/9$. For the $|V;H\rangle$ and $|H;V\rangle$ components, there is a $2/9$ probability that the H -polarized photon will be transmitted to the side of the V -polarized qubit while the V -polarized photon is not lost, resulting in an effective bunching error in that qubit. Bunching errors can only be

detected by measurements in the output ports. However, since only two photons entered the setup, and since no additional photons were generated, it is sufficient to measure the total photon number in only one of the two output ports. In a network of quantum gates, it is necessary to keep track of the propagation of bunching errors, since it is possible that the photons become unbunched again at some point, causing undetectable errors in the total network operation. Within a larger network, it may therefore be most efficient to combine the postselected gate proposed here with the previous proposals [2,3] for an optimized total efficiency of the network. In particular, it may be useful to apply this quantum gate in the last stages, where postselection in the output is not so problematic.

At the present stage of development, the postselected gate proposed here may already be sufficient to realize small multiqubit networks. Up to now, most operations on photonic qubits have not gone beyond qubit pairs, and even the generation of three or four photon entanglement has only been achieved by postselection in the outputs [5,6]. This is related

to the fact that the most common method of generating photon number states is by unpredictable spontaneous downconversion events. When this method of photon generation is used, the rate of coincidences between multiple emission events drops exponentially as more and more events are required. It may therefore be extremely difficult to implement networks using optical quantum gates that require additional photon inputs such as the ones proposed in [2,3] with conventional technology. The postselected quantum gate proposed here minimizes the number of coinciding photons by requiring only the reliable generation of an input pair carrying the quantum information. An N -qubit network could then be realized using an N -pair coincidence in the downconversion processes.

In conclusion, the postselected quantum gate is more simple to implement and more efficient than previous proposals. It could thus contribute to the realization of multiqubit processing by significantly reducing the technological requirements for optical quantum gate operations.

-
- [1] Q. A. Turchette, C. J. Hood, W. Lange, H. Mabuchi, and H. J. Kimble, *Phys. Rev. Lett.* **75**, 4710 (1995).
[2] E. Knill, R. Laflamme, and G. Milburn, *Nature (London)* **409**, 46 (2001).
[3] T. C. Ralph, A. G. White, W. J. Munro, and G. J. Milburn, e-print quant-ph/0108049.

- [4] S. Takeuchi, J. Kim, Y. Yamamoto, and H. H. Hogue, *Appl. Phys. Lett.* **74**, 1063 (1999).
[5] D. Bouwmeester, J.-W. Pan, M. Daniell, H. Weinfurter, and A. Zeilinger, *Phys. Rev. Lett.* **82**, 1345 (1999).
[6] J.-W. Pan, M. Daniell, S. Gasparoni, G. Weihs, and A. Zeilinger, e-print quant-ph/0104047.