



HOKKAIDO UNIVERSITY

Title	Toward an interpretation of dynamic neural activity in terms of chaotic dynamical systems
Author(s)	Tsuda, Ichiro; 津田, 一郎
Citation	Cambridge University Press, 24, 793-810 https://doi.org/10.1017/S0140525X01000097
Issue Date	2001-06
Doc URL	https://hdl.handle.net/2115/6084
Rights	Copyright © 2001 Cambridge University Press
Type	journal article
File Information	BBS24-5.pdf



Toward an interpretation of dynamic neural activity in terms of chaotic dynamical systems

Ichiro Tsuda

Applied Mathematics and Complex Systems Research Group, Department of Mathematics, Graduate School of Science, Hokkaido University, Sapporo, 060-0810 Japan tsuda@math.hokudai.ac.jp
www.math.sci.hokudai.ac.jp/~tsuda

Abstract: Using the concepts of chaotic dynamical systems, we present an interpretation of dynamic neural activity found in cortical and subcortical areas. The discovery of *chaotic itinerancy* in high-dimensional dynamical systems with and without a noise term has motivated a new interpretation of this dynamic neural activity, cast in terms of the high-dimensional transitory dynamics among “exotic” attractors. This interpretation is quite different from the conventional one, cast in terms of simple behavior on low-dimensional attractors. Skarda and Freeman (1987) presented evidence in support of the conclusion that animals cannot memorize odor without chaotic activity of neuron populations. Following their work, we study the role of chaotic dynamics in biological information processing, perception, and memory. We propose a new coding scheme of information in chaos-driven contracting systems we refer to as *Cantor coding*. Since these systems are found in the hippocampal formation and also in the olfactory system, the proposed coding scheme should be of biological significance. Based on these intensive studies, a hypothesis regarding the formation of episodic memory is given.

Keywords: Cantor coding; chaotic itinerancy; dynamic aspects of the brain; dynamic associative memory; episodic memory; high-dimensional dynamical systems; SCND attractors

1. Introduction

In recent studies in neuroscience, dynamic aspects of the brain have been the subject of a good deal of investigation. There has also been an accumulation of data that cannot be rationally explained within a static framework. Recently, it has been suggested in various contexts that the brain is organized not only in a hierarchical fashion but also in a “heterarchical” fashion. In this context, the word “heterarchy” refers to structure or states existing in reticular networks, in contrast to hierarchical structure or states. According to this point of view, a single neuron or a neuron assembly is represented by a single code and also by a multiple code; the information representation is realized both by the state of neurons and by the *dynamic* relation among states.

In neural network models of biological information processing, it has been assumed that an attractor in phase space (state space) represents external and/or internal information. In other words, it has been assumed that a neural network maps the structure of information contained in the external and/or internal environment into embedded attractors (see, for example, Amari 1974; 1977; Amari & Maginu 1988; Kohonen 1972; 1982; Hopfield 1982). With this assumption, if the static representation of information is universal, the concept of an attractor should be adequate for neural representation (Hirsh 1989).

Recently, however, dynamic modalities of neuroactivities have been observed as, among other types of phenomena, a coincidence of random spikes (for example, Abeles 1991; Aertsen et al. 1994; Fujii et al. 1996; Oliveira et al. 1997;

Riehle et al. 1997), as coherent activity in neuron assemblies (Aertsen et al. 1987; Arieli et al. 1996), as the synchronization of oscillatory spike trains (Deppisch et al. 1993; Eckhorn et al. 1988; Engel et al. 1992; Gray & Singer 1987; 1989; Gray et al. 1990; Singer 1994), as chaotic population dynamics in the γ -range (Freeman 1987; 1994; 1995a; 1995b; Kay et al. 1995; 1996), as chaotic interspike intervals giving rise to a chaotic fluctuation of membrane potentials (Hayashi & Ishizuka 1995). We have adopted the framework of chaotic dynamical systems to *interpret* the functions of dynamic neural activity emerging in the brain, which can be regarded as a *hermeneutic device* (Érdi 1996) that can act in a hermeneutic process (Érdi & Tsuda, in press; Tsuda 1984).

The dynamical systems’ interpretation of dynamic neural activity with chaos analysis has also been presented (see, for example, Babloyantz & Lourenço 1994; Érdi et al. 1993; Freeman 1987; 1995a; Kaneko & Tsuda 1996; Nicolis 1982; 1991; Nicolis & Tsuda 1985; Tsuda 1984; 1990; 1991a). In these works it has been shown that chaos can be effectively used for biological information processing. Types of com-

ICHIRO TSUDA holds the post of Professor in the Department of Mathematics, Hokkaido University, as well as Visiting Professor at the Japan Advanced Institute of Science and Technology. He was group leader of the Basic Design Group, National Biocholonics Project of the Research Development Corporation of Japan and has published widely in the field of dynamical processes and the brain.

plex dynamical behavior, such as chaos, can be categorized in terms of quantities including topology, measure, and dimension. The functional form of a decay of amount of information also categorizes chaos according to the ability of a chaotic network to store spatial patterns using the dynamic orbits (Matsumoto & Tsuda 1985; 1987; 1988). The forms of chaotic behavior observed in biological systems possess a common feature: a nonuniform probability density and a weak instability. The probability distribution of chaotic dynamics is biased due to excitability and its bifurcation parameter, which is a control parameter, is biased due to biological specificity. The former bias is responsible for the network ability mentioned above, and the latter bias results in a restricted high-dimensional process. From these considerations, it is seen that chaos appearing due to a weak instability cannot be restricted to merely a low-dimensional phase space. Thus transitory dynamics in high dimensions emerge.

Since biological neural networks operate in noisy environments, the interplay between their deterministic model dynamical systems and noise is an important subject for study. Taking into account this issue and those discussed in the previous paragraph, in this paper we study the roles of *critical* chaos in biological information processing with regard to, in particular, the inseparability of dynamic memory and perception. Based on new concepts of high-dimensional dynamical systems, we present a hypothesis on the formation of dynamic memory and perception. This hypothesis accounts for dynamic functional processes such as episodic memory and the itinerant process of perception. This hypothesis clarifies the biological significance of the chaotic activity observed in the hippocampus and in the olfactory system. The hypothesis also suggests a form of the *prototype* of thoughts.

2. Perception and dynamic memory

Studies of neural correlates of memories have developed through investigation of the hippocampus, the olfactory system, the temporal cortex, the prefrontal cortex, and their interacting systems. The working memory (Baddeley 1986; Funahashi et al. 1989; Goldman-Rakic 1987; 1996; Sawaguchi & Goldman-Rakic 1991) as a cognitive modality can be dynamic and is easily destabilized in the state space. In contrast, the episodic memory can be stabilized in state space, but it appears in association with dynamic cognitive processes. Finally, the semantic memory must be described as a stable object. On the other hand, neural activities associated with these kinds of memories seem a highly random spatio-temporal pattern. If these neural activities correspond precisely to memories, it is unlikely that they would be represented by a single attractor in state space, but rather by a more unstable one. This observation leads to the following conclusion: Memories do not emerge entirely from stored information. Rather, the nature of that which emerges is influenced at each instant by “traces” of information resulting from perception and cognition.

Motivated by the above conceptual observation, we have constructed a neural network model of dynamic memory in terms of mathematical objects that are not attractors in the conventional sense (Tsuda 1991b; 1992; 1994; Tsuda et al. 1987). This model is discussed in the next section from another viewpoint.

There are interesting experimental results demonstrating the dynamic relations between perception and memory. In particular, an experiment conducted and a model constructed by Freeman and his colleagues have attracted general attention (Skarda & Freeman 1987). In both Freeman’s work (1995a) and Kay’s work (Kay 1995; Kay et al. 1995; 1996), it is claimed that odor memories are represented by the chaotic behavior of the collective activity of the olfactory bulb, and that the process of odor perception can also be represented by itinerant motion of local EEGs in the olfactory bulb, in the olfactory cortex, and in the hippocampus. It was found that in the animals’ motivated state during the process of learning, which is inevitably associated with the recall and the perception processes, the neural activity is chaotic (Freeman 1995a; Kay et al. 1995; 1996).

The studies of Freeman and Kay suggest that chaos underlies the entire process of odor perception, and this process is inseparable from the dynamic memory process. Among a number of noteworthy findings of Freeman and his colleagues, a key finding was that animals do not respond directly to external stimuli, but rather to internal images created by chaotic dynamics in the olfactory bulb (Freeman 1995a; 1995c). This suggests that the brain is hermeneutic (interpretative) in nature and exhibits chaotic behavior (Tsuda 1984; 1991a). Furthermore, Skarda and Freeman (1987) offer a hypothesis on the role of chaos in the dynamic processes of perception and memory. According to this hypothesis, without chaos animals can neither record nor perceive odor. As described in the next section, the dynamic behavior exhibited by our theoretical model strongly suggests that their hypothesis is correct.

For other modalities of sensation, the dynamic receptive field may be understood as a neural correlate of dynamic perception like a perceptual drift (Freeman 1995a). Dynamic (spatio-temporal) receptive fields have been observed in the retina (Mizuno et al. 1985; Tsukada et al. 1983), the auditory cortex (Eggermont et al. 1981), and the primary visual cortex (Dinse 1990; 1994). It was pointed out that there exist subfields, some of which are activated for only 20–50 msec during a presentation of stimuli; the combination of activated subfields varies even for a stationary presentation of stimuli. In the theory of the dynamic receptive field, a classical receptive field, which is understood as static one, is reinterpreted as a spatio-temporal average of the dynamic receptive field. The spatial average should be taken over an entire receptive field, and the temporal average over a few hundred milliseconds. Since the time scale 20–50 msec is approximately a “unit” of psychological time, we may consider the dynamic receptive field as a neural correlate of internal dynamics for restructuring and/or reorganization of mental space (Dinse 1990), in other words, the presence of a dynamic receptive field suggests the presence of dynamic restructuring due to dynamic interactions between higher and lower levels of information processing (see also Dinse 1994).

Concerning the processing of visual information, Gray and Singer (1987; 1989) and Eckhorn et al. (1988) found neural oscillations of around 40 Hz in the primary visual cortex. These findings followed studies giving evidence for the presence of γ -range oscillations (Bressler & Freeman 1980; Freeman 1987). As an underlying mechanism for these oscillations, the synchronization of neuron spikes may

be conjectured. It was actually conjectured that one of the roles of spike synchronization is to extract the invariant continuum as a figure out of diverse stimuli, and consequently to bind different modalities of stimuli (Eckhorn et al. 1988; Gray & Singer 1987). This is reminiscent of Abeles's (1991) synfire chain, proposed to describe how neuron assemblies in the prefrontal cortex can obtain useful information from purely random spike trains through coincident and phase-locked firings.

In the prefrontal cortex, after Abeles's proposition of the synfire chain, Vaadia, Aertsen, and others observed the coincidence of neuron spikes, and Aertsen et al. analysed these data precisely (Aertsen et al. 1994; Vaadia & Aertsen 1992). Aertsen et al. found a new functional representation of neurons, which can be compared with the so-called rate coding. Fujii et al. (1996) has proposed a dynamic cell assembly hypothesis, based on the concepts of coincidence detecting neurons and functional connectivities resulting from coincidence (see also Aertsen et al. 1996). Recently, Diesmann et al. (1999) constructed a neural network model for synfire-chains.

Our main concern here is not formulating a coding scheme at the level of a single neuron. Rather, we cast our description in terms of macro-variables that represent macroscopic behavior observed as collective motion (see the Technical Appendix). These macro-variables can in turn limit the possible types of coding scheme at the level of a single neuron. In this respect, our viewpoint is similar to that of statistical physicists and dynamicists (see, for example, Amit 1989; Amit et al. 1985; 1987; Babloyantz 1986; Haken 1979; 1983; 1991; Mayer-Kress 1986; Sompolinsky & Crisanti 1988; Sompolinsky & Kanter 1986), where the understanding of Haken leads to the idea that *pattern formation is pattern recognition*). A crucial point in the treatment we employ, which distinguishes our treatment from the conventional treatments of statistical physics and dynamical systems, is that the macro-variables we consider do not behave as simple functions, such as a constant function or a function periodic in space and time, and in this sense they are fundamentally different from *order parameters* (see the Technical Appendix). The description of the chaotic behavior in which we are interested necessitates the use of these mathematically more general macro-variables. Such chaotic behavior cannot always be described by a low-dimensional attractor. We thus need a dynamical description that captures the high-dimensional complex dynamics. Another crucial problem is to describe the interplay between the order parameter and the "rest" of the system – that is, the interplay between the deterministic dynamics and the noise. In the next section, we consider these issues in relation to neural dynamics.

We take the view that there exists a neural correlate of cognitive behavior. The inadequacy of the symbolic approach to higher functions of the brain, which has been used in the field of artificial intelligence, was clearly pointed out by Skarda and Freeman, who showed the biological significance of chaotic behavior found in local EEG. Additionally, it should be noted that a sharp distinction cannot be drawn between the molecular-level timescale and the psychological timescale. For instance, one can observe psychological events at some timescale, say 1 sec, and also observe molecular events and electric events over almost the same timescale. Hence there exists an overlap of timescales. In addition, there are overlaps of many other

timescales. For these reasons, it is not appropriate to describe cognitive behavior as simply a "macroscopic" behavior. It is thus necessary to study the interplay between macroscopic and microscopic behavior and from this to propose a plausible cognitive interpretation of neural activity. For this purpose, we study the dynamic behavior in non-equilibrium neural networks, which gives a skeleton description of behavior observed in the brain.

In this article we study two kinds of networks. One is a stochastic recurrent network, and the other is a chaos-driven stable network. Based on this study, we present hypotheses on dynamic memory and perception.

3. Dynamical systems with and without noise as a tool for interpretation of neural activity: Changeover of interpretation from low-dimensional attractor to high-dimensional itinerancy

3.1. What is noise in neural systems?

In order to clarify the origin of noise, let us consider a system consisting of many interacting elements. Here an "element" is assumed to obey a deterministic law, so that it entails no unknown component. In cortices, the system in which we are interested consists of on the order of 10^5 to 10^{10} the interacting neurons. Such a system is called deterministic because of the absence of stochastic behavior. The system may, however, be intractable as a deterministic system in the practical sense, because it contains too many degrees of freedom. Then, one may attempt, in the sense of mode-mode coupling theory, to identify collective modes to act as an order parameter. This approach succeeds in the critical regime of equilibrium phase transitions, and it can be extended to bifurcation points in nonequilibrium states (see for example Haken 1983). Here, the collective mode is decoupled from the residual modes, since the collective mode is low frequency, whereas the residual modes are high frequency. In other words, in such a treatment the slow motion on the center manifold is decoupled from the fast motion involved in the convergence to the center manifold. Here, the collective mode can be described by deterministic equations with a few degrees of freedom, and the rest is viewed as *noise*.

Noise is dynamically *generated* in such manner, but it is usually assumed to contain infinite degrees of freedom. Hence, as is shown in Figure 1A, the interaction between the order parameters constituting a deterministic system and noise is unidirectional. However, this condition is broken when order parameters, that is, collective modes, become weakly unstable in a direction normal to the center manifold, as the slow motion begins to interact with fast motion.¹ Then the number of variables behaving like noise changes in time. Figure 1B depicts this situation. An asymptotic theory, in general, provides an effective method to obtain a center manifold. Then, once one obtains the center manifold of interest the stability of states within this center manifold must be investigated. In the situation we study here, however, stability in the direction normal to the center manifold must be investigated, using an index like a normal Lyapunov exponent.

Taking into account the situation as described above, it is plausible to think of a neural network in the brain as existing in a noisy environment even in the absence of thermal

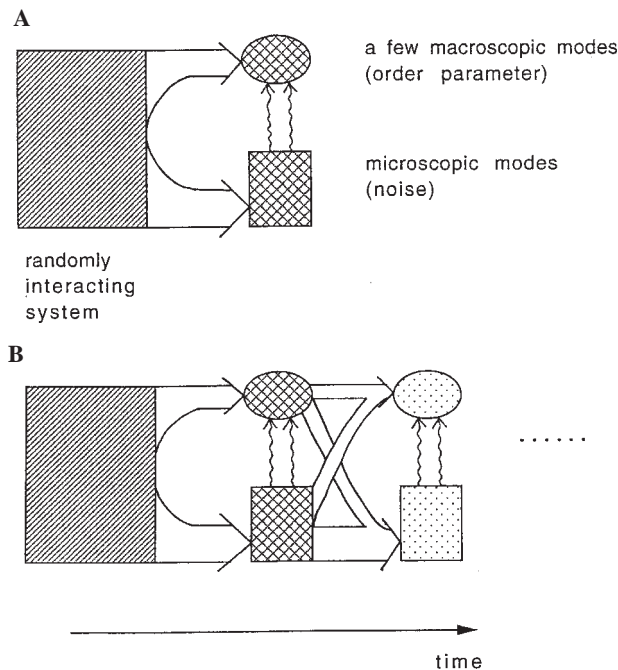

Figure 1. (A) Unidirectional interactions between order parameters representing a deterministic system and noise. (B) Order parameters and the rest can be varied in a weak instability regime. The components that play the role of noise change with time.

noise and quantum noise. Since neurons can process information even in such a noisy environment, in our model “noise effects” must be taken into account.

An additional type of noise we have not yet mentioned has been observed in neurons. This type of noise differs from that discussed above in that it originates in non-deterministic factors. The following two types of noise can be distinguished. One type results from electric current randomly leaked from neighboring neurons. We refer to this as *dendritic* noise. The second type results from quantal emissions of synaptic vesicles. There are two kinds of quantal emission, spontaneous emission and stimulus-induced emission.

Spontaneous emission is too weak to activate the postsynaptic membrane. Actually, a single such process simply induces a change on the order of several μV to the postsynaptic membrane potential.

For the firing to be effective, emission on the order of 10^4 over all connecting neurons must occur within the decay time of membrane potential. Taking into account the maximal number of synapses per neuron and the average decay time of a membrane potential, this is unlikely to occur. Thus this type of noise cannot in itself represent information. It should, however, be noted that it may influence the subthreshold dynamics.

This kind of noise may play a decisive role in the reduction of the effective dimension when delay-differential equations are used to describe the networks. A system with delay terms is described as an infinite dimensional dynamical system. In such a system, the infinite number of variables generated by the delay allows for highly complex behavior of high dimension. In this case, noise can reduce the complexity of the system, because noise divides a continuous delay time into some finite intervals within which cor-

relations among some finite variables are preserved. Hence the effective dimensionality can be reduced by noise.

On the other hand, stimulus-induced stochastic emission, which is referred to here as *synaptic noise*, can be effective for the firing, since a single such process provides an effect on the order of several mV . Thus here, a coincident emission on the order of only 10 among $\sim 10^4$ synapses is sufficient to cause a firing. In the study of model systems, it will therefore be necessary to consider the effects of dendritic and synaptic noise.

3.2. The interplay between the dynamical system and noise

In this subsection, we highlight the difference between digital and analog computations and the related role of noise. This issue is of importance in order to properly address the role of noise in excitable biological systems, like neural systems. Excitable systems are, in many cases, sensitive to noise, because of the presence of a separatrix between states (i.e., the firing states and resting states) or the presence of an extremely nonuniform vector field. The latter occurs in physiological situations described by the Hodgkin-Huxley equation. Furthermore, an interacting system of such elements often possesses a critical regime of stability.

Some deterministic models with a few degrees of freedom used to describe the Belousov-Zhabotinsky reaction system exhibit only periodic oscillations when studied on digital computers, but the digital simulation of these models with a noise term as well as the analog simulation of the deterministic model exhibit “chaotic” oscillations also (Showalter et al. 1978; Tomita & Tsuda 1979). These oscillations have topologies and probabilistic properties that are similar to those observed in the actual Belousov-Zhabotinsky system (Roux et al. 1981).

Higher-dimensional dynamical systems like the KIII model of Freeman and our model for the dynamic association of memory also is sensitive to noise. The KIII model possesses a tiny basin of attraction whose size is reduced to the size of the digitizing unit (around 10^{-16}) due to attractor crowding as the number of coupled oscillators is increased. Such a situation prevents locally unstable states from appearing. Thus noise is necessary to obtain aperiodic orbits stably (Freeman 1997). Our model, which will be introduced in the next subsection, consists of two components, the deterministic system and two kinds of noise terms. The deterministic part consists of a multi-Milnor attractor system whose stability is critical. Hence, without noise terms, its asymptotic solution is like that of a multi-stable state system in the sense that one of the Milnor attractors is eventually selected, depending on initial conditions. However, the dependence on the initial conditions in the present case may be more complicated than in the case of a multi-stable state system. A Milnor attractor is a kind of generalized attractor that may be neutrally stable, as it can possess unstable directions. For further discussion, see section 3.4, and for a precise definition see the Technical Appendix.

Furthermore, contrary to conventional belief, it is possible that digital computation will create spurious periodic orbits (Yamaguchi 1997).

These points suggest that the digital computation of a high-dimensional dynamical system with an excitable element like a neuron or even a neuron population could lead

to fatal error. Apparently, the simulation of excitable biological systems demands careful treatment regarding the interplay between deterministic and stochastic components of the system. In the context we consider, it will be fruitful to study systems in regimes in which chaos does not exist but chaotic behavior generated by noise appears and systems that can be stabilized by noise, as in the case of *noise-induced order* in chaotic systems (Matsumoto & Tsuda 1983) and *stochastic resonance* in multi-stable systems (see, e.g., Liljenström et al. 1996). These studies should be more relevant to neurosciences than studies of low-dimensional deterministic chaos, because the brain seems to employ a mechanism by which it distinguishes ordered motion in noisy signals.

3.3. A model for dynamic associative memory

A nonequilibrium neural network model was proposed (Tsuda et al. 1987) to investigate the neural correlate of the dynamic association of memory and dynamic perception. This network consists of two blocks, one (called block I) containing a recurrent net and positive and negative feedback connections whose strengths are randomly fixed, and the other (called block II) constructed from the same network as in block I except for the addition of a specific negative feedback connection (see Fig. 2).

The skeleton of the model was based on Szentagothai's works (1975; 1983) on the network structure of the cerebral cortex. It is likely that the skeleton possesses a structure seen in the mammalian cerebral cortex. In the cerebral cortex, the existence of a recurrent net is insured by a distribution of axon collaterals of pyramidal cells, though only a few neighboring neurons are connected to any given neuron. A Hebbian synaptic learning can be assumed in the network. The existence of a positive and negative feedback to this network is guaranteed by the distribution of stellate cells and basket cells. These neurons can cause a dynamic change of the collective internal states of pyramidal cells. The specific negative feedback existing only in block II may result from specifically formed inhibitory neurons like the Martinotti cells or the axonal tuft cells.

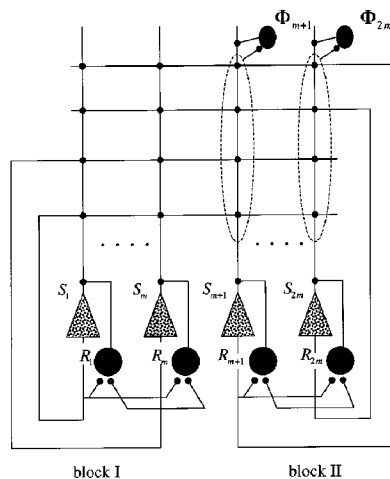

Figure 2. Skeleton network for dynamic associative memory. The network consists of two blocks, I and II. Block I consists of a recurrent network of a pyramidal-type neuron and a network providing global feedback, whose strength is randomly fixed. Block II consists of the same network as in block I with the addition of specific negative feedback connections.

There are several possibilities for the function of the specific inhibitory neurons. We give here three examples.

(1) A pyramidal cell fires, an inhibitory neuron may receive its output and as a result act to reduce the output.

(2) The inhibitory neuron may receive information corresponding to the internal state like the membrane potential of the pyramidal cell and then work to reduce the output of the pyramidal cell with a strength proportional to this internal state.

(3) If the pyramidal cell is in a steady state, the inhibitory neuron may receive such information and then act to inhibit the firing of the pyramidal cell.

In all of these cases, the role of the inhibitory neuron is to temporarily hide the information contained in the state of the pyramidal cell. In our model, the state of the pyramidal cell is reset to the initial state when the information is hidden. The connections between two blocks may mimic intra- and/or inter-cortical connections, where again Hebbian synaptic learning is also assumed.

Two modifications are made in order to see the effects of dendritic and synaptic noise. First, extremely small additive noise terms are introduced to represent dendritic noise. Second, a type of *stochastic renewal of dynamics* is adopted to represent synaptic noise. The second dynamics consists of two independent rules for evolution of which one is selected randomly at each time step. With stochastic dynamics of this type, a neuron does not always output a pulse even if the sum of the inputs exceeds the threshold at a certain time. At a given time, according to pre-determined probabilities, either a particular neurodynamics is selected (i.e., a threshold dynamics is employed), producing some output, or simply the same output as that for the previous time is used. The two maps used here thus constitute a contracting IFS (iterated function system) (Barnsley 1988; Tsuda 1991a). Therefore, the overall dynamic behavior is determined by the parameter that indicates the degree of the instability of the Cantor sets produced by the IFS. This instability is due to the reset caused by the specific inhibitory neurons.

A "chaotic" transition among memories can occur, depending on the values of the assigned probabilities for choice of a specific neurodynamics. If such a probability value is given by the inverse of the number of neurons, then the model is equivalent to the Hopfield model (1982). Thus the existence of steady associative recall is also certain. Increasing the probability, a chaotic transition, (dynamic recall) occurs. This transition in block II is a bit artificial, because of the presence of specific inhibitory neurons, whereas in block I the transition is self-organized (i.e., it is an emergent property of the network), since it occurs even in the case of infinitesimal connection strength between blocks I and II. It should be noted that memories can be represented by an *exotic attractor* in spite of the fact that we use Hebbian learning. If the system is composed of a recurrent net only, then memories are represented by an attractor in the usual sense. The appearance of exotic attractors is due to the introduction of specific inhibitory neurons. In the next subsection, we extend the concept of the attractor. As we will see, the exotic attractor here can be identified with a Milnor attractor.

Choosing an appropriate coordinate, the transition can be described by the critical stage of a circle map, which is known as a typical chaotic map. In Figure 3A and B, we show the one-dimensional map representation of the transition.

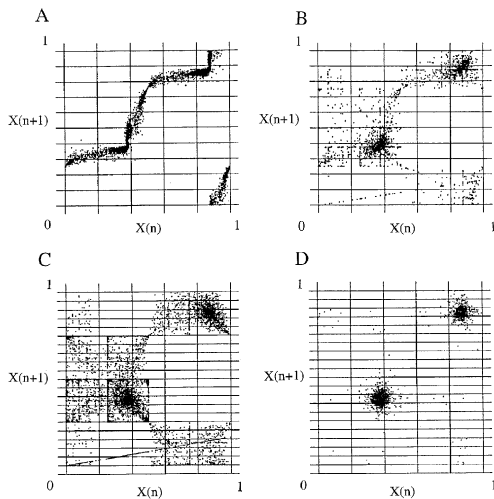

Figure 3. (A) and (B) correspond to a one-dimensional map representation of the chaotic transition among memory traces. (C) and (D) correspond to a one-dimensional map representation of a random transition due to an addition of noise. The abscissa denotes the internal state of the network at a discrete time step n , and the ordinate the internal state at the next time step $n + 1$. In (A) and (C), strongly correlated patterns are learned, and weakly correlated patterns are learned in (B) and (D). The functional relation between the internal states for the present and the next time step is clearly seen, especially in (A). Also, in (B), a skeleton of the one-dimensional map is seen. This is not seen in the case of the random transition ((C) and (D)). The one-dimensional map in (A) provides an emergent dynamic rule for the chaotic transition.

The dimension of the transitions is a decreasing function of the correlation among memories (Tsuda 1992). Compared with this chaotic transition, a random transition among memories occurs in a deterministic network with dendritic noise only, which is depicted in Figure 3C and D. This situation is equivalent to the case of simulated annealing.

Following the study producing Figure 3, a similar chaotic transition has been observed in other network models, for instance, in chaotic neural networks with refractory periods (Adachi & Aihara 1997; Aihara et al. 1990), in neural networks with dynamic masking (Körner et al. 1989; 1991), in associative networks with memory of the limit cycle type (Nara & Davis 1992; Nara et al. 1995), in associative cognitive networks controlling robot movements (Tani 1992), and in a modified Hopfield network for the travelling salesman problem (TSP) (Chen & Aihara 1995; Nozawa 1994; Tokuda et al. 1997). (See also Horn & Opher 1996 as an independent but similar study.)

From these studies, it has been found that such chaotic transitions can be used for problem solving in various fields. We discuss below basic functions of networks exhibiting this type of emergent property.

In this article, we would like to propose several hypotheses regarding dynamic memory and perception, based on the results of our investigation of several model systems. Then, a basic network model is constructed using in one case a modified recurrent net like the one treated in this subsection, and in another case a unidirectional coupling (a skew product) of an unstable network with a stable network, where a chaotic network like the one treated here can be adopted as the unstable network.

Before proceeding to the main topic, the introduction of new concepts of high-dimensional dynamical systems is

necessary. The next three subsections are devoted to this. First, in the next two subsections, we discuss the concept of *chaotic itinerancy*, which was proposed in order to capture the essence of complex transitions in high-dimensional dynamical systems.

3.4. Chaotic itinerancy, ruins, and Milnor attractors

We proposed the concept of *chaotic itinerancy* as a universal dynamical concept in high-dimensional dynamical systems (Ikeda et al. 1989; Kaneko 1990; Tsuda et al. 1987; Tsuda 1991a; 1991b). In low-dimensional dynamical systems, which have been adopted as a tool for the interpretation of neural activity, four classes of attractors are known: fixed points, limit cycles, tori, and strange attractors. They are used to represent a steady state, a periodic state, a quasi-periodic state, and a chaotic state, respectively. Chaos can be characterized by the presence of a positive Lyapunov exponent, which represents the orbital instability defined by the exponential increase of separation of nearby orbits on average. With this characterization, chaos can exist also in high-dimensional dynamical systems. One example is hyper-chaos, which is characterized by the presence of more than one positive Lyapunov exponent (Rössler 1983). The chaotic transition among memories discussed above, however, leads us another type of chaotic behavior.

Let us imagine a multi-stable system of high dimension. As long as each of these stable states is represented by an attractor, one attractor is separated from the others by separatrices, forming a basin of attraction. Then, the asymptotic behavior corresponds to one such attractor, depending on the initial conditions. What happens following the destabilization of the system? If the instability is sufficiently strong, many chaotic modes appear, and consequently the system moves toward a turbulent state, that is, a very noisy macroscopic state. In this case, not even a "trace" of the original attractors remains. (The present meaning of the word "trace" is made clear below.)

If, however, the instability is not so strong, an intermediate state between order and disorder can appear. The dynamics of such a state may be regarded as those of an itinerant process, indicating a correlated transition among states. Here, the state of the system before the instability corresponds to an attractor, but after the appearance of the instability this is no longer the case. In this case of weak instability, a crucial characteristic is that a "trace" of the original attractor remains in spite of the generation of unstable directions in the neighborhood of the attractor. Such an itinerant process often becomes chaotic. A destabilized attractor is called an *attractor ruin*, and the corresponding overall behavior is called *chaotic itinerancy* (Fig. 4, see also Technical Appendix). In this situation, an attractor of the destabilized system consists of a collection of attractor ruins and itinerant orbits connecting attractor ruins. We refer to this new type of attractor as an *itinerant attractor*.

Attractor ruins are closely related with Milnor attractors (Milnor 1985). A Milnor attractor is a kind of generalized attractor that may possess unstable directions. A Milnor attractor is defined as a minimal limiting set whose initial points possess positive (Lebesgue) measure, and hence the presence of unstable directions is allowed (see Technical Appendix for precise definition). It should be noted that a Milnor attractor is a limiting set, but dynamical orbits can escape from it due to small (even infinitesimal) perturba-

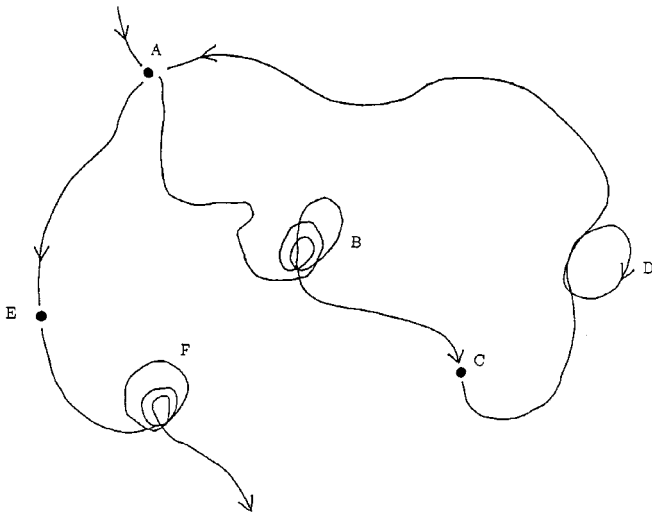

Figure 4. Schematic drawing of chaotic itinerancy. Dynamical orbits are attracted to a certain attractor ruin, but they leave via an unstable manifold after a (short or long) stay around it and move toward another attractor ruin. This successive chaotic transition continues unless a strong input is received. An attractor ruin is a destabilized Milnor attractor, which can be a fixed point, a limit cycle, a torus or a strange attractor that possesses unstable directions.

tions. A trivial but typical example of a Milnor attractor is a fixed point in a map at a tangent bifurcation (i.e., a saddle-node bifurcation). Such a map and point are depicted in Figure 5. In this Figure, the fixed point p is the unique asymptotic state for any starting point. A similar structure of phase space is observed in a one-dimensional map representation of the chaotic association of memories (see Fig. 3A), but in the case of chaotic transitions, the Milnor attractor collapses due to the nonlinear interactions and stochastic renewal of the neurodynamics. Figure 6, which is a two-dimensional representation of the transition, also shows the flow in the neighborhood of degenerate attractor ruin. In this figure both the dynamic inflow and outflow of orbits can be seen.

In the case of neither noise terms nor dynamical interactions among variables, the orbits approach a Milnor at-

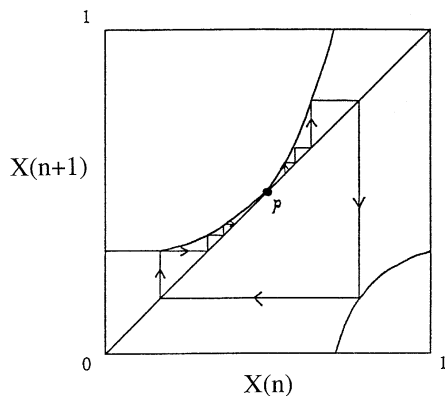

Figure 5. The simplest Milnor attractor in a one-dimensional map. The abscissa denotes a state at a discrete time step n , and the ordinate a state at $n + 1$. There is only one fixed point, p , in this map. This fixed point is a unique asymptotic state for any starting point.

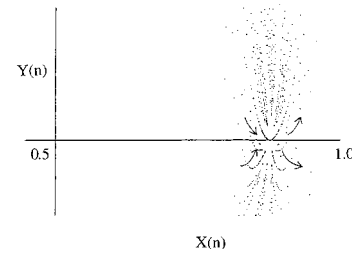

Figure 6. A two-dimensional representation of a chaotic transition. Arrows denote the direction of motion. The dynamical orbits approach a fixed point, but they then escape from it. Hence the fixed point can be regarded as a ruin of a Milnor attractor.

tractor, even if this Milnor attractor is embedded in a higher-dimensional space. Instability due to dynamic interactions or noise is thus necessary for the appearance of chaotic itinerancy. The structure of phase space in the neighborhood of attractor ruins is complex, and this structure may be related to *riddled basin boundaries* often appearing in multi-attractor systems (Grebogi et al. 1987; Kaneko 1997). It is plausible that such a complex boundary is destabilized and comes to chaotic orbits connecting attractor ruins.

A transition through chaotic itinerancy is topologically quite different from a transition resulting from noise in multi-attractor systems. In Figure 7 the schematic drawing clarifying the difference is shown. In the latter, which has been dealt with in previous studies, the external noise is necessary to obtain the transitions. On the other hand, in the former, the entire phase space is decomposed into several subspaces, and in each subspace the system is stable, as characterized by the Lyapunov exponents within each subspace, but in a direction normal to a subspace the system is unstable, as characterized by the “normal” Lyapunov exponents. Since for each subspace the normal Lyapunov exponent is positive, the set representing an asymptotic state of the dynamics restricted to each subspace is unstable, and thus it is not an attractor in the conventional sense. It is, however, a Milnor attractor.

One may think that a Milnor attractor is structurally unstable, as it exhibits such critical behavior as that appearing in saddle-node bifurcations. It is not difficult, however, to construct a model in which a change of parameter values preserves such a critical regime. Actually, only the bifurcation parameter in our neural network model is given by the probabilities determining the renewal process of mappings, and Milnor attractors are preserved through the change of the other system parameters, such as the connection strength of nonmodifiable synapses and input biases. Thus chaotic itinerancy is represented in a quite different manner from stochastic transitions caused by external noise in the attractor landscape. “Pasting” subspaces together (shown in Fig. 7B) on the time axis according to the development of the dynamics, one can understand the concept of an *epigenetic landscape*, proposed by Waddington, in which dynamics are embedded.

3.5. Information structure of chaotic itinerancy

The information structure of chaotic itinerancy may provide foundation for description of dynamic information processing in the brain. Since chaotic itinerancy has actually been observed in animal motivated learning (see for ex-

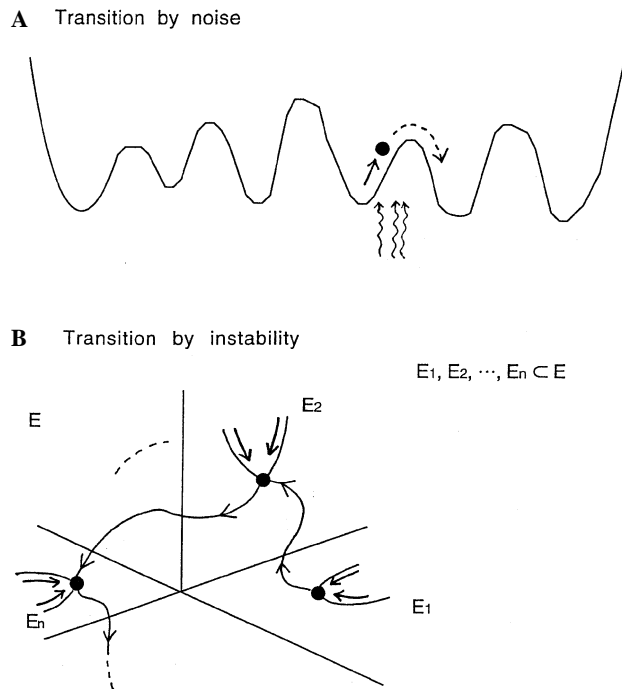

Figure 7. The difference between transitions created by producing chaotic itinerancy and by introducing noise. (A) A transition created by introducing external noise. If the noise amplitude is small, the probability of transition is small. Then, one may try to increase the noise level in order to increase the chance of a transition. But this effort is not effective because the probability of the same state recovering is also increased as the noise level increases. In order to avoid this difficulty, one may adopt a simulated annealing method, which is equivalent to using an “intelligent” noise whose amplitude decreases just when the state transition begins. (B) A transition created by producing chaotic itinerancy. In each subsystem, dynamical orbits are absorbed into a basin of a certain attractor, where an attractor can be a fixed point, a limit cycle, a torus, or a strange attractor. The instability along a direction normal to such a subspace insures a transition from one Milnor attractor ruin to another. The transition is autonomous. Recently, Komuro constructed a mathematical theory of chaotic itinerancy with the same idea as demonstrated in (B), based on the investigation of itinerant behavior appearing in the coupled map lattices found by Kaneko (Komuro 1999).

ample, Freeman 1995a; 1995c; Kay et al. 1995; 1996), it may be possible to use it for the *dynamical interpretation* of cognitive processes. We investigated the information processing of neural networks in the case that the network exhibits chaotic itinerancy, drawing on the information theory of chaos (Matsumoto & Tsuda 1985; 1987; 1988; Nicolis 1991; Nicolis & Tsuda 1985; Oono 1978; Shaw 1981). We summarize this investigation below.

3.5.1. Dynamic retention of information. *Information is dynamically preserved in the chaotic behavior of a network of nonuniform chaos* (Matsumoto & Tsuda 1987; Tsuda 1992).

There exist neurons whose activity is characterized by the skewness of the distribution of interspike intervals caused by the skewness of the distribution of membrane potentials. The latter skewness stems from the excitability of the membrane. For this kind of system, the amount of information contained in the initial distributions, which is measured by the mutual information between states of the

system, slowly decreases in the form of an exponential or power law in time. Here, the mutual information between states indicates the information existing commonly in both states. When information given in the form of probability distributions is fed into a network of such chaotic neurons, it is found that the information propagates in the network without loss. This property has been demonstrated in a general framework.

3.5.2. Learning capability. *The learning capability of neural networks increases in the presence of chaotic itinerancy.*

This proposition is based on a numerical study of Hebbian learning (Tsuda 1992). Since Hebbian learning works locally in phase space, it usually strengthens the stability of learned patterns. Hence, superfluous learning representing learning beyond a critical capacity of memory simply strengthens one particular memory, or destroys most memories. Chaotic itinerancy as a dynamic process of a network endows Hebbian learning with a different feature. Let us define the critical memory capacity of a network as the largest number of memories in the case of usual associative network learning, in which only a single association of memory for a single input occurs. Our model network exhibits successive association represented by chaotic itinerancy as well as this single association, depending on the value of the system’s parameter, that is, the probability value for choice of the dynamics. Thus, one can compare the memory capacity in successive association with that in single association. We found about a fifty percent increase of the capacity in the case with chaotic itinerancy, compared to the case without chaotic itinerancy.

How can chaotic itinerancy save the network from “Hebbian break” described above? Since the state of the network continually changes even under learning so that the dynamical orbits link memory states, the dynamical paths linking memory states are also strengthened in spite of the locality of Hebbian learning. Thus, superfluous learning is possible, implying that the memory capacity is beyond the conventional capacity. This scenario has been verified by another numerical experiment in which random transitions among memory states induced by noise occur, though the orbits become uncorrelated due to noise. Actually, we did not find an increase of memory capacity in this experiment (Tsuda 1992).

3.5.3. Pattern recognition. *Neural networks exhibiting chaotic itinerancy can judge whether or not any input is close to one of the memories.*

Let us assume that a memory is represented by the state of a neural network *independently* of context (this is the vector representation). The closeness between two representations can be expressed, for instance, by their inner product. Numerical simulations have shown that the network outputs a particular memory if the input is close to this memory, whereas it outputs chaotic itinerancy if the input is far from all memories (Tsuda 1992). This characteristic of the network dynamics is independent of the type of embedded patterns and the input patterns.

3.5.4. Pattern search. *Neural networks exhibiting chaotic itinerancy can perform an effective search of memory.*

Distinct from a random search with noise and a simulated annealing with sophisticated noise, a pattern search with chaotic itinerancy is quite effective because of the for-

mation of internal rule linking memories. In chaotic itinerancy, a dynamical rule for linking orbits emerges. This rule gives rise to a causal relation among memories. The numerical calculations demonstrated that the memories close to each other are likely linked. When one wishes to obtain a certain memory state as an output of a network but has only incomplete information regarding this memory, it is necessary to search in memory space with only this partial knowledge. A random search follows chance, and simulated annealing requires sophisticated noise whose amplitude is controlled by both the current state of the network and the potential landscape. A search with chaotic itinerancy, on the other hand, simply follows a dynamically changing rule created in the network, which provides a dynamic relation among memories. Thus the memory in question is output after several linking stages. This characteristic of chaotic itinerancy has actually been used to effectively solve the travelling salesman's problem (Chen & Aihara 1995; Nozawa 1994; Tokuda et al. 1997) and also to provide an effective method for pattern recognition (Nara et al. 1995).

3.5.5. Simultaneous process of learning and recall. *Neural networks exhibiting chaotic itinerancy can simultaneously perform learning and recall.*

In conventional neural network models, the learning phase and the retrieval of memories phase must be split in order to avoid creation of spurious memories. In other words, if these phases are not split, spurious patterns are also memorized. As a result there is serious confusion of "true" memories and "spurious" memories. On the other hand, the presence of chaotic itinerancy permits this simultaneous performance of learning and retrieval. In this case, no confusion results, since spurious memory states inevitably produced during the learning constitute dynamical orbits which link "true" memories (Tsuda 1992; 1994).

3.5.6. Representation by process. *Memory is represented not by a state but by a process.*

Memories formed in a network model via a Hebbian learning algorithm are represented by states. When a neural network is described by a dynamical system, the state can be expressed as an attractor. As we have shown in studies of such models, however, memory is in general described by a Milnor attractor, which is not always an attractor in the conventional sense. Then a "trace" such as that consisting of an attractor ruin is a representation of memory and the memory trace is manifested through the transition process. Here the transition process, that is, the linking process of ruins, is reasonable. In other words, memories are realized only when they are linked to each other.

3.5.7. Indistinguishability. *Memory and information processing cannot be distinguished.*

Regarding Proposition 3.5.6, in our conscious experience, memories are always manifested in the *current* process of cognition. This view has been proposed by a number of people. Among them, Elman (1990), in discussing dynamic memory in the context of machine learning of language, asserted that memory is inextricably bound up with the rest of the processing mechanism. Goldman-Rakic (1996) also asserted, through her neurophysiological studies, that a *working memory* can be classified as so-called short-term memory, but it cannot effectively be dis-

tinguished from the working *process*. Our studies support the plausibility of this indistinguishability.

Let us now discuss the biological significance of the above propositions. The olfactory bulb receives odor input, but the correlation between the bulb's activity and the behavior of the animal in question stems not from external input but from internal input coming from the olfactory cortex, hippocampus, and amygdala (Bressler & Freeman 1980). This feedback information generates chaotic activity of the bulb (Freeman 1987). Thus, the bulb can be regarded as an *interface* between the external odorant world and the internal odor world. Here, dynamic behavior like chaotic itinerancy is likely generated as an interfacial dynamics (Rössler 1987) which facilitates the formation of coordinates where external inputs are compatible with internal images.

Such interfacial dynamics can be seen in other areas where "higher" and "lower" level information meet. The hippocampus-parahippocampus system is one possible such area in the sense that here the neural activity of the frontal cortex meets the sensory inputs. A neuron in the frontal cortex generates only a few spikes per second, and even in the sub-areas directly connected to the motor cortex a neuron exhibits at most a few tens of spikes per second, whereas a neuron in the sensory cortex can usually generate a few hundreds of spikes per second. If a dynamical system or a noisy dynamical system is responsible for the firing mechanism, chaotic itinerancy is expected to exist, because it can also be generated by the interaction of the dynamical system with distinct timescales (Okuda & Tsuda 1994). Furthermore, massive recurrent connections controlled by inhibitory neurons in the CA3 of the hippocampus can act as a dynamic associative network like our model. Thus, we anticipate that chaotic itinerancy facilitates the formation or collapse of memory traces, controlled by a certain marker, generated probably in the frontal cortex, such as "somatic marker" of Damasio (1995; 1996). Actually, chaotic behavior has been found by Hayashi in CA3 neurons (Hayashi & Ishizuka 1995), and it has also been shown that the spatio-temporal representation of information is embedded in at least CA1 (Tsukada et al. 1996). Tsukada et al. found that the information encoded in the higher order statistics (at least 2nd order) of spike sequences can be extended as spatial information of the hippocampus CA1. Taking into account these points, it is likely that Propositions 3.5.1–3.5.5 hold in the hippocampus-parahippocampus system.

Another possible area for interface is the inferotemporal cortex, where a complex figure is represented by neural activity for some short period (Miyashita 1988; 1993; Miyashita & Chang 1988).² In order to perform a task, an animal must retain an image of the key figure until the next cue comes. Since retention can be viewed as a concurrent process of storage and recall, it is likely that the experimental conditions themselves force the animal to simultaneously carry out the write-in and the read-out of the information concerning this key figure. From the fact that neural networks with chaotic itinerancy can dynamically preserve an external input and can perform the concurrent process of the write-in and read-out of information, Miyashita's finding suggests that Propositions 3.5.1 and 3.5.5 hold in the inferotemporal cortex. Such a concurrent process can also be observed in a stable network driven by a chaotic network. This point will be discussed in the next subsection.

3.6. SCND attractors and Cantor coding

Our next concern is another type of dynamic behavior that generically appears in a chaos-driven contracting system. Here we treat unidirectionally coupled networks, where an unstable network generating chaotic behavior plays the role of a “driver,” and a stable network plays the role of a “receiver.” In other words, this system consists of a stable network driven by a chaotic network. This kind of network appears as a unidirectionally coupled network from CA3 to CA1 in the hippocampus and also as a forward network from the olfactory bulb to the prepyriform cortex. These two systems are our concerns in this article. A unidirectionally coupled network also appears more commonly in, for example, the prefrontal cortex → the motor cortex, and the visual cortex → the temporal cortex. There could be feedback loops in most areas, but it is plausible that the forward pathways (looked at from primary sensory levels toward higher cortices) are used to send a basic code for the information, while the backward pathways are used to send the code for the context. The presence of feedback loops does not lead to a contradiction of the discussion below if the forward system is contractive and the backward system is unstable.

Chaos-driven contracting systems possess another type of attractor called SCND (singular-continuous but nowhere-differentiable) attractors (see Technical Appendix). It would be particularly interesting to see the information structure embedded in the stable network when the unstable network acting as a driver exhibits a sequence of events via chaotic itinerancy, because such a coding may be related with the formation of “episodic” memory and primitive “thoughts” processes.

The SCND attractor is an attractor represented by a SCND function (Rössler et al. 1992; 1995; Tsuda 1996; Tsuda & Yamaguchi 1998). The precise definition of a SCND function is given in Technical Appendix; here it is enough to think of a fractal image on a discrete set like a Cantor set (see Technical Appendix) as a graph of such a function. In chaos-driven contracting systems, no one can see an attractor itself, since it appears in a slow dynamical process in which the discrete set like the Cantor set is generated in some cross-section of a differentiable dynamical system. Only finite subsets, each of which contains a finite number of elements, can be observed.

The dimension of a SCND attractor exceeds its topological dimension³ by more than 1, whereas the difference between two dimensions in a conventional strange attractor is less than 1. Thus the SCND attractor is “fat,” distributed in a wide domain of phase space. This dimensionality insures the robustness of coding on the attractor, which is discussed below.

Rössler found a mechanism for the emergence of this kind of attractor (Rössler et al. 1992). In a simple neural network model, we recently demonstrated the presence of such an attractor (Fig. 8).

The SCND attractor generally appears in a contracting space when contracting dynamics are driven by chaotic dynamics, provided that the speed of contraction in the former is lower than the largest speed of expansion in the latter. It could thus be observed in stable neurons or neuron assemblies that are connected with chaotic neurons or neuron assemblies.

In our study, a SCND attractor generated in the mem-

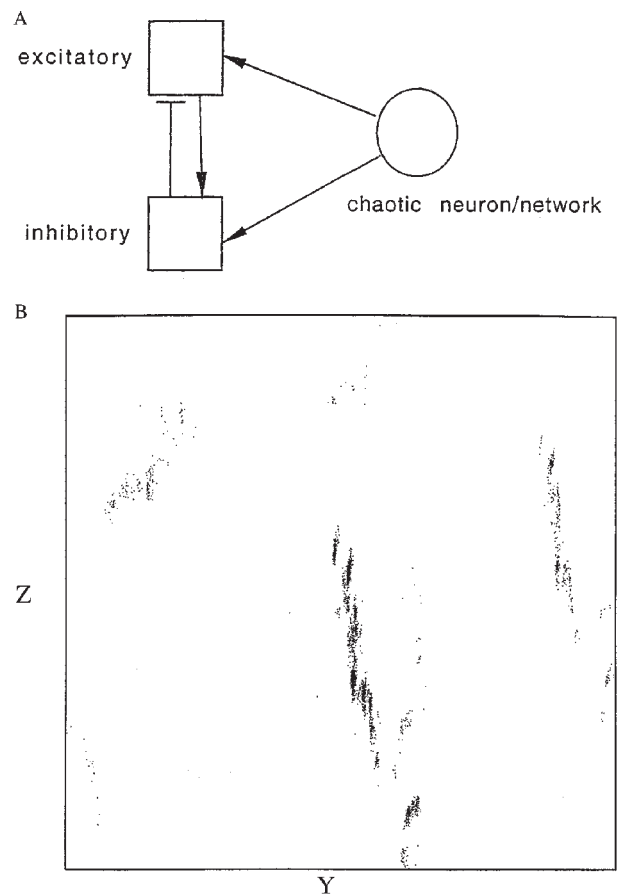

Figure 8. (A) A schematic drawing of the model exhibiting SCND attractors consisting of three neurons/neural networks: one is a chaotic neuron/neural network and the other two are stable excitatory and stable inhibitory neurons/neural networks. The stable neurons/neural networks' activities form a contracting subspace. (B) An example of SCND attractors.

brane potential of an excitatory neuron is fragile with respect to external noise, but that generated in the membrane potential of an inhibitory neuron is robust with respect to noise. Therefore, it has been predicted that the SCND attractor will be observed in the potential of inhibitory neurons which are driven by chaotic neurons (Tsuda 1996).

Nearby orbits in phase space become separated due to expanding dynamics and approach each other again due to contracting dynamics. In chaotic dynamics, nearby orbits become separated on average. This results in the presence of a positive Lyapunov exponent. From the information theoretical point of view, expanding dynamics can act as the read-out process of information, and contracting dynamics can act as the write-in process. Because in chaotic dynamics the expanding and contracting phases depend on the position in phase space, the read-out and write-in processes appear successively in the time series. The presence of a positive Lyapunov exponent indicates that the overall dynamics on average represent the read-out process of the information contained in the initial conditions.

On the other hand, in chaos-driven contracting dynamics, the information read out by chaos is written in the contracting subspace by the contracting dynamics. More concretely, symbol sequences created by chaos are encoded as an element of the set in the contracting subspace. A code

table is thus formed on the SCND attractor. Actually, the one-to-one correspondence between the symbol sequence generated by chaos and the position of Cantor elements has been elucidated (see Fig. 9).

The coding scheme in this study reminds us of the coding scheme employing a fractal image generated in iterated function system (IFS) (Barnsley 1988), and also of the coding scheme employing the Cantor set in recurrent neural networks (RNN) (Elman 1990; 1991; Kolen 1994a; 1994b; Pollack 1991). The former work presents a method of compressing spatial patterns, whereas the latter works present a method of encoding temporal patterns. According to the *totally disconnected IFS theorem* proved by Barnsley, if and only if there is no overlap in fractal images constructed by any two invertible maps which constitute a contacting IFS,

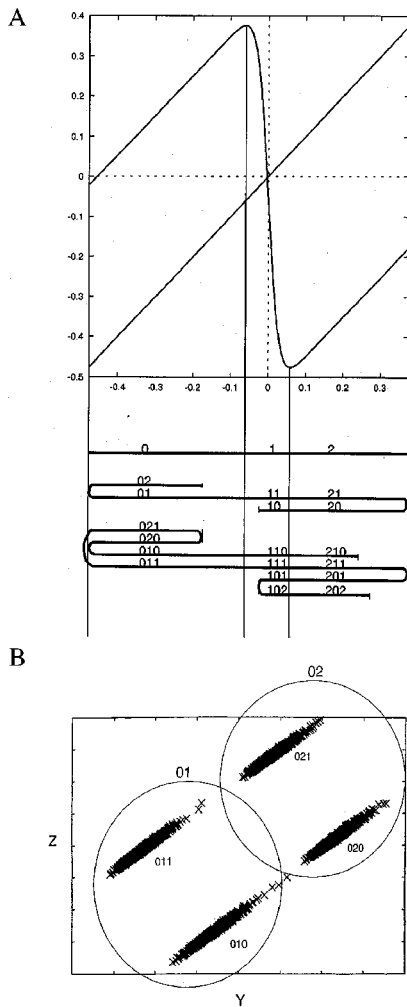

Figure 9. The hierarchical structure of an SCND attractor represented by symbol sequences encoding chaotic orbits. (A) The chaotic neuron map (Aihara et al. 1990) adopted here can produce symbol sequences consisting of, e.g., 0, 1, and 2. The abscissa denotes the states at discrete time steps n , and the ordinate the states at $n + 1$. Thus the figure is a graph of a one-dimensional map which can represent the activity of a chaotic neuron. Below the chaotic neuron map, the first, second and third transformations of the interval are shown, accompanied by the symbol sequences indicating the labeled orbits starting from the points in the respective subintervals. (B) An example of Cantor coding. Each cluster in the Cantor set has a code generated by a chaotic neuron map. Each cluster contains further depths of hierarchy of code. The second depth is shown in the figure by splitting each cluster.

the IFS is totally disconnected, and hence the unique coding. Kolen (1994a; 1994b) proved that a type of second order RNN known as sequential cascaded network is equivalent to the set of affine transformations of an IFS if the transformation function is linear, so that the theorem is applicable to Cantor coding even for temporal patterns.

In our system – a chaos-driven contracting system – a strong contraction can allow the existence of non-overlapping elements of the SCND attractor, but overlapping is determined by the nature of the nonlinearity responsible for the existence of the chaotic behavior in the system under study. Thus it is not easy to quantify this condition. If we do not use chaotic dynamics but simply a random number generator as the driver, this overlapping problem can easily be solved, since the only condition for the existence of a unique coding scheme is the strength of contraction. On the other hand, if a contracting IFS is used as the receiver, the existence of a unique coding scheme is possible even in the case that chaotic dynamics are used as the driver, due to the presence of forbidden symbol sequences resulting directly from the grammatical structure of symbol sequences inherently embedded in the chaotic dynamics. With the same contraction strength as in the above case, the use of uncorrelated random noise, such as white Gaussian noise, may bring about overlapping fractal patterns. In such a case, the coding is only defined up to some finite number of significant digits (Ichinose et al., preprint; Ryeu et al., in press).

In the context of the machine learning of languages, Elman (1990) reconstructed a hierarchical structure embedded in the input word sequences as snapshots of the internal states of some RNN during the process of the input. Pollack (1991) found that a Cantor coding can be realized in recurrent neural networks as a dynamical recognizer. These two studies are within the framework of PDP (parallel distributed processing) (Rumelhart & McClelland 1986). Their noteworthy finding is that the hierarchy of a Cantor set is generated in the phase space of the neural network which can encode a grammatical structure of English sentences.

The noise effects for the SCND attractor can be investigated using physical quantities such as the dynamical entropy and mutual information. These quantities have been computed up to the limit of digital computations, which is demanded to obtain precise values (Tsuda & Yamaguchi 1998). For a small amount of noise (up to $\sim 10^{-4}$ for a system size of 1), it was found that these quantities do not change to a precision of 6 significant figures. On the contrary, these quantities decrease, as increasing the noise level up to $\sim 10^{-3}$. The computations at this noise level reached the computation limit. Although the mechanism responsible for this kind of stability of the attractor with respect to noise is still under study, it is certain that the state corresponding to a Cantor set can be observed even in noisy environments. In dynamical systems without noise, a measure-zero set, like a Cantor set, can be observed as a limiting state if it is dynamically stable. If the contraction rate in a dynamical system with noise is sufficiently large, compared with the amplitude of noise, even a measure-zero set is observable. Furthermore, since the SCND attractor is widely distributed in phase space because of its dimensionality mentioned above in contrast to a conventional Cantor set, the size of the overlapping region due to noise is reduced. This results in a reduction of the ambiguity of the code. These factors account for the effectiveness of the code on a measure-zero set.

Our concern with regard to robustness is maintenance of the Cantor coding in the presence of external noise. Since the SCND attractors can be sparsely distributed in phase space because of the dimension gap mentioned above, a code that is fragile with respect to noise easily drops in the Cantor gaps (Siegelmann & Sontag 1994), where no code exists. In this sense, one can judge if a perturbed pattern is the correctly encoded one. Furthermore, orbits slightly perturbed by noise promptly return to their original positions where the dynamical orbits possess a Cantor code due to the effect of contraction. Therefore, one can observe a Cantor code on the cross-section even in a noisy environment if the rate of the impingement of noise on the system is low compared with that of the development of dynamics. The numerical studies of entropy and information mentioned above also indicate the robustness of the coding scheme, as evidenced by the invariance of entropy and information with an addition of a small amount of noise.

4. Hypotheses for dynamic memory and perception

4.1. Dynamic memory and Cantor coding in the hippocampus

Using the concepts of high-dimensional chaotic dynamical systems discussed in the previous section, we would like to propose here a model for the formation of sequences of sensory events that may suggest the neural correlate of episodic memory (Mishkin 1982). For this, we are concerned with the dynamic behavior of hippocampal networks.

The activity of hippocampal CA3 has been analyzed under isolated but close to physiological conditions, and it was concluded that it is highly probable that the CA3 pyramidal neurons can exhibit chaotic activity under physiological conditions (Hayashi & Ishizuka 1995). If the CA1 neurons are stable in the absence of any input and the CA3 neurons are chaotic, the contracting space defined by the CA1 network will be driven by the chaotic CA3 network via the Shaffer collaterals. It was also recently found that the information embedded in the higher statistics of temporal pattern inputs can be encoded in the real space of CA1 (Tsukada 1994; Tsukada et al. 1996).

The situation can be created in which the positions of elements of the Cantor set in phase space indicate the magnitudes of membrane potentials of neurons, that is, the number of spikes, or local EEG. A local difference of magnitudes in real space brings about a global difference in the network activity via the propagation of waves. Hence the Cantor code in phase space can also be embedded in the spatial pattern of the network activity. Since there are recurrent circuits from the CA1 neuron to the CA3 neuron via the neocortex and the parahippocampal area, the dynamics on the recurrent circuits over such a wide range may work cooperatively to accomplish both encoding and decoding in a single process.

Concerning the long-term potentiation (LTP) in CA1, various artificial stimulations applied to the Shaffer collaterals of the CA3 pyramidal neurons have also been investigated. It was found that chaotic input with long autocorrelation (i.e., *intermittent chaos*) are the most effective for LTP (Tatsuno & Aizawa 1997; 1999).

We here use a simple model as a skeleton network. As a

model for the CA3 chaotic network, we adopt our model of dynamic associative memories discussed above or modified version of it. Using this kind of model, we characterize the dynamic features of the CA3 network and its functional relation. As a model for the CA1 network, we employ a stable network consisting of excitatory and inhibitory neurons. An excitatory neuron receives CA3 outputs via Shaffer collaterals and also receives the output of a few neighboring inhibitory neurons. An inhibitory neuron, on the other hand, receives the output of each excitatory neuron.

In our framework, the CA3 network is a device for the generation of a sequence of patterns. The existence of such a sequence is insured by the presence of chaotic itinerancy. The distance between (or the closeness of) memories represented by a spatial pattern of neuron activity can be specified in CA3 by the extent of attracting areas in phase space. Defining the distance between sequences is, however, impossible in CA3, because only the states of a network are basic variables in such a phase space. Therefore, it is reasonable to conjecture that such a definition can only be made in CA1. In fact, it can be made by means of the hierarchies embedded in the SCND attractors, in the same way shown in Figure 9. We have verified the existence of such a hierarchical coding in the model CA1 network of *any* temporal sequence given by the stimulations of the Shaffer collaterals. We have also verified the existence of hierarchical coding in the model CA1 network when the model CA3 network produces a temporal sequence of patterns linked by chaotic orbits. The details of this study will be published elsewhere (Tsuda & Kuroda, in press).

4.2. Dynamic memory and Cantor coding in the olfactory system

The hard-wired condition necessary for the presence of SCND attractors could hold in many areas of the brain. Freeman (personal communication) pointed out as a possible such area the prepyriform cortex for olfaction, which receives synaptic connections from the olfactory bulb, where dynamic activities such as chaotic itinerancy appear. In the prepyriform cortex, the network consisting of excitatory and inhibitory neurons could provide stable behavior and thus could form a contracting space. Thus SCND attractors will be observed in the prepyriform cortex.

Memories of olfactory sensation are created in the olfactory bulb. These memories are expressed as chaotic activities of neuron assemblies. Odor memories may be linked with higher level's functions as well as being directly linked with emotion. Thus odor memories could be associated with episodic memories. Since olfactory information is sent also to the entorhinal cortex, olfactory information is likely abstracted, at least at the level of the prepyriform cortex (see also Fig. 10). Olfactory information could be encoded and decoded concurrently by the combination of chaotic activities in the bulb and SCND attractors in the cortex. In this process, the entorhinal cortex, whose activity also exhibits itinerant transitions among attractor ruins, may act as a type of a history-dependent continuous perception (Kay et al. 1996).

4.3. Episodic memory

Based on the above detailed theoretical and numerical considerations, we now propose an interpretation of the formation of episodic memory (Fig. 11).

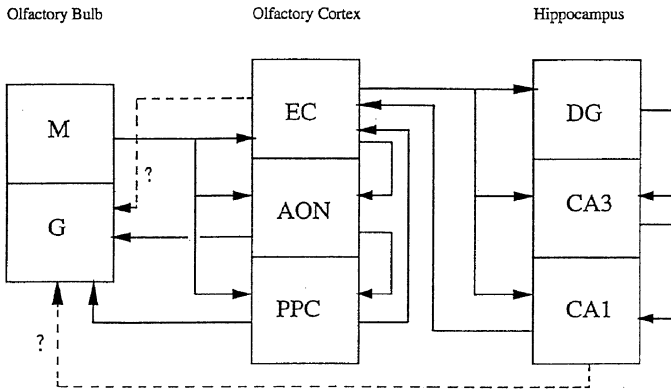

Figure 10. The information flow in the olfactory system (modified from L. Kay 1995). The meaning of the symbols follow. M: Mitral cells, G: Granular cells, EC: Entorhinal cortex, AON: Anterior olfactory nucleus, PPC: Prepyriform cortex, and DG: Dentate gyrus.

Episodic memory is memory concerning the information of individual experiences (Tulving 1972). Here, an “individual experience” is not a series of events which one actually experiences in daily life, but, rather, is identified with the structure of dynamic neural activity created internally that is associated with the sensory input during such events. Thus such an individual experience (or “episode”) is dependent on the spatio-temporal context of the individual. It is convincingly argued in reports on H.M. (Scoville & Milner 1957) and R.B. (Zola-Morgan et al. 1986) that the hippocampus is responsible for episodic memory.

In the modeling, it is important to note that the structure of CA3 is very similar to that of the neural network model of associative memory (see, e.g., Amari 1977; Kohonen 1978). Since the work of Marr (1971) there have been many model studies with this structural similarity. These studies are based on the idea that the hippocampus temporarily retains episodic memory as an associative memory (see for example McClelland et al. 1995; Treves & Rolls 1994). Since conventional associative memory models possess attractor dynamics only, an additional mechanism is necessary to create temporal patterns which may represent episodes. As seen in sections 3.3 and 3.4, the presence of inhibitory interneurons satisfies the condition for the generation of temporal patterns. It is known that such inhibitory neurons exist in CA3 (Buzsáki 1996). Taking these points into account, in the present article we further develop the theory of episodic memory.

The situation we consider is that in which a given itinerant chaotic sequence generated by one network gives rise to a unique Cantor coding in another network. Actually, this situation is insured in a certain type of simple neural network model. Furthermore, in our theory for the formation of episodic memory, we associate the above mentioned chaotic network with the CA3 network and the stable one with the CA1 network.

A variety of memory sequences is created in CA3 by means of chaotic itinerancy. In some short period, say on the order of a hundred milliseconds, only a few transitions may occur. For instance, there may be a transition from (semantic) memory P_1 to P_2 via intervening chaotic behavior. We label this transition a_2a_1 . This label can be embedded in the Cantor set generated in the space of the membrane

potential of CA1. This label is also hierarchically represented by one of the subsets of the whole set. This code is sent to the entorhinal cortex and also to the neocortex. Among the diverse pathways to the neocortex, the pathway to the prefrontal cortex is emphasized here by the property of the close functional relations to the motions, which may be a key to the formation of episodic memory. The connections from CA1 to the entorhinal cortex shown in Figure 10 are used to send this kind of information (see also Tsukada 1992).

It is likely that in the neocortex and also in the entorhinal cortex such a code is stored. Although there must be a difference between the codes of the two cortices – such as

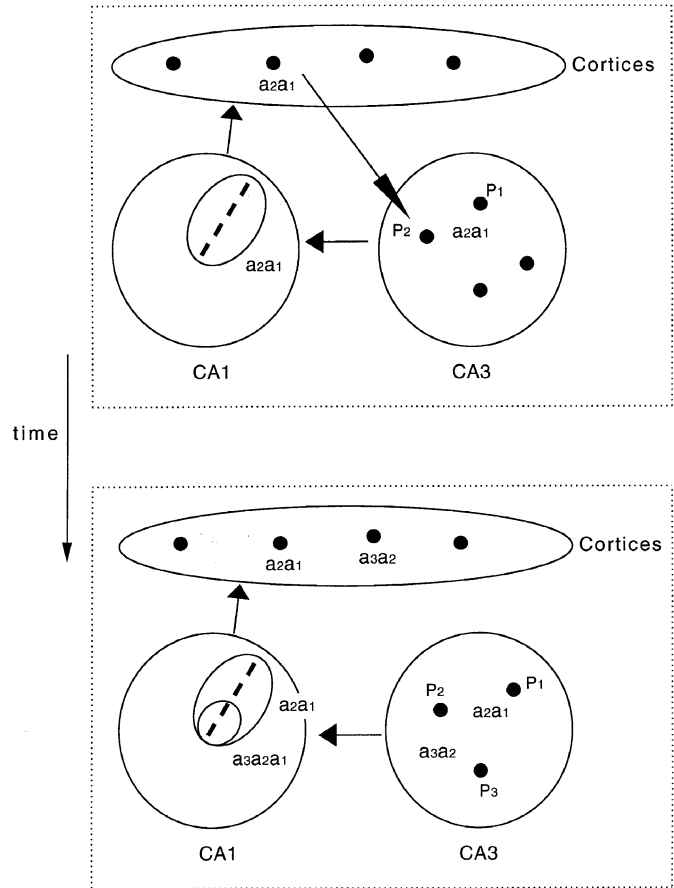

Figure 11. A hypothetical information flow in the formation of episodic memory. Sensory information is temporarily stored as a pattern of the network activity in CA3. However, it is not represented by a conventional attractor, but rather by an exotic attractor, such as a Milnor attractor. The metric in pattern space is measured in CA3 by the extent of the basin of attraction. Because of the instability of Milnor attractors, pattern sequences are generated. These sequences denote the sequence of the experience of sensation. The metric with respect to pattern sequences is defined in CA1 by the Euclidean distance between elements of the Cantor set. This information is sent to the entorhinal cortex and also to the neocortex, where a short sequence of patterns appearing as a result of the transitions during a short period of time (say 100 msec) is represented by, for example, a fixed point of the Milnor type. The transition between these Milnor attractors in the cortices represents a concatenation of the transitions. If the most recent pattern appearing in the concatenated sequence is successfully followed by a current pattern in CA3, the correct sequence of sensory experience can be reconstructed.

abstract and inferential in the neocortex and emotional and sensational in the entorhinal cortex – two cortices may play similar roles for the hippocampus, namely giving the *content* of information to the hippocampus (Buzsáki 1996). We thus think that the coding scheme in the two cortices must be similar, though the content, that is the meaning, differs.

Let us assume that the cortices process information temporarily stored in the unstable sub-networks which have structure similar to that of the hippocampus CA3. Then, in the cortices, labels like a_2a_1 can be expressed as a fixed point attractor in Milnor's sense. If an input to hippocampus CA3 with such a label a_2a_1 from the cortices coincides with the instability of P_2 in CA3, then the next transition in CA3 (namely from P_2 to, for example, P_3) is reinforced. If no coincidence between them exists, the input from the cortices to CA3 will disturb the transition process itself in CA3. Another mechanism seems to be necessary in order to avoid the possibility that the matching occurs accidentally. A "somatic marker" hypothesized by Damasio (1995; 1996) may provide a mechanism controlling chaos, as mentioned in section 3.5.

The memory sequence $P_1P_2P_3$ is encoded in CA1 in a deeper level of the hierarchy of set than in the sequence P_1P_2 . Thus the code $a_3a_2a_1$ embedded in the set in CA1 is sent to the cortices. This stimulation can afford the transition from one fixed point to another, which are expressed by the codes a_2a_1 and a_3a_2 , respectively, in the cortices. This transition reinforces the correct sequence of memories. It may provide a mechanism of the formation of *episodic memory*.

We have highlighted so far the Cantor coding of the transition process. One may also propose the Cantor coding of another type, for example, the Cantor coding of memory sequence itself. Then, chaos linking the memories does not manifest in the code sequence itself. We, too, can construct such a model (Tsuda & Kuroda, in press).

In the formation of episodic memory, the relation between pattern sequences in CA3 and the geometry of the Cantor set in CA1 may be flexibly altered, whereas in cortices the alteration of the representation due to structural changes will be slowly varied. In this respect, the hippocampus may be likened to a blackboard: The timing between writing and erasing on this hippocampus "blackboard" and slowly varying transition among symbols in the cortex is a key to the formation of episodic memory. This illustrates the necessity of a long period of time, from a few years to a lifetime, for the complete formation of episodic memory, as can be understood by considering the existence of retrograde amnesia for one to three years as well as anterograde amnesia after hippocampal deprivation (Scoville & Milner 1957), and also after sustainment of a CA1 lesion (Zola-Morgan et al. 1986).

Finally, it is interesting to note the recent work of Tani (1998). Tani found that chaotic behavior appears in the internal states of his recurrent network which controls robot learning when conflicts arise between the bottom-up perception and the top-down prediction. Tani interpreted this chaotic neural activity as an indication of awareness. In our theory, chaos is considered to be a reflection of not only conflicts between the hippocampal and the cortical activity but also of intentionality (Freeman 1999) from the cortex to the hippocampus (also see the Appendix). Furthermore, chaotic itinerancy among semantic memories may reflect a perceptual drift, and therefore it may be the case that the

interplay between the cortex and the hippocampus produces episodic memory. If this is true, then the existence of a variety of temporal sequences of semantic memories would be insured in CA3, and the temporal sequences would be encoded hierarchically in phase space of CA1. Also, the Cantor set appearing in CA1 would provide a measure of "distances" between episodic memories.

5. Concluding remarks and outlook

We discussed in this article dynamical models of dynamic associative memory and episodic memory in which chaotic itinerancy and SCND attractors are linked in terms of the Cantor coding. In relation to this, a dynamic mechanism for the concurrent process of the read-out and write-in of information was proposed. The indistinguishability of memory from information processing – thus, perhaps, from cognitive processes – was suggested. This dynamic mechanism and indistinguishability seem to characterize the human cognitive process.

We emphasized the biological significance of chaotically itinerant attractors in high-dimensional systems, but one can raise the criticism that "chaotic" behavior observed to this time in the brain may not be chaotic in the mathematical sense (Freeman 2000; Rapp 1995). Referring to the discussion in sections 3.1 and 3.2, it should be noted that the phenomena we can observe in laboratories can clearly be described as the chaotic behavior of noisy systems, in other words, chaotic behavior in a dynamical system with additive or multiplicative noise or stochastic renewal. Thus it would seem that chaos does exist in the real world in some form, although what we actually observe as chaotic behavior is dependent on our point of view. Also, we note that in an excitable system with sensitive dependence on noise, noisy chaotic behavior can appear due to the interplay between a prechaotic state and noise. Even if mathematical chaos does not exist in such an excitable system, the interplay of the system with the noise may create "chaotic" behavior possessing topology similar to that of some truly mathematically chaotic behavior. For this reason, the model studies are effective to understand the causation underlying chaotic phenomena.

Our theory supports the notion of the dynamic brain, which has been investigated in various contexts, as mentioned in the Introduction. The *chaotic aspects of the brain* described by our theory may change the conventional interpretation of brain functions (see also Freeman & Núñez 1999).

Since Brodmann introduced functional maps of cerebral cortex, it has been believed that it is decomposed into different conceptual areas, each of which is responsible for a specific single function. This belief resulted in the conclusion that the cortical functions can be hierarchically represented by a combination of subfunctions corresponding to these areas (or simply the "sum" of them). This concept of functional localization may lead to another concept that a single neuron is responsible for merely a single representation of information, namely, the concept of "single neuron-single representation."

Although much experimental evidence has been published to support the presence of such a neuron, its existence is still questionable, since other experiments strongly suggest the multiple function of single neurons (Dinse

1990; 1994). The multiple function of an area was also reported for Broca's area (Paulesu et al. 1993). Broca's area has been thought to be related only with writing and articulation of speech, but the activation of the area by inner speech alone has been observed (Inui 1997; 1998; Paulesu et al. 1993). Inui (1997) has pointed out, based on the experimental report of Imamura et al. (1996), that Area 45, a portion of Broca's area, must be responsible not only for the prediction of phonetic sequences but also for the learning and prediction of motor sequences. It can be concluded that the multiple function observed in Broca's area is the result of dynamic interactions between Broca's area and neighboring areas (Inui 1997; 1998).

The notion of hierarchical organization of functional modules and the notion of a direct mapping of the information regarding an environment into the states of a neural net are based on the conventional systems theory, which are summarized as follows:

1. Each function is allocated to a respective element of the system, namely to a neuron or a module. A higher function is obtained by unifying or binding distinct lower functions.

2. A feature of external stimuli (for instance, the orientation of lines, edges, color, etc., for vision) is directly mapped to each neuron or to each module. The processing of information proceeds, taking the combination of such features, which may be realized through synaptic learning.

The dynamic behavior discussed here may, however, lead us to consider aspects of the brain that sharply contrast with those considered within the conventional framework, namely the chaotic aspects of the brain. These can be summarized as follows:

- (i) The function of a system's element is dynamically determined so that the entire function of the system is realized. Since this entire function varies in a manner determined by the changing environment and the system's purpose, a function of each element cannot be uniquely determined. Therefore, the functional unit can be varied. Even if a module is organized as a subsystem, the hierarchical structure of modules will not be seen, because the boundary between modules is inevitably altered due to the change of *relations* among elements which depend on the entire function. Thus "heterarchical" structure, referred to as "moiré patterns" by Szentágothai (1978) appears.

- (ii) Higher information in the brain is not always represented by the combination of lower information but, rather, represented by dynamic properties emergent via the chaotic activity of neurons and/or the neural network.

Furthermore, if the brain is composed of static functional modules, the organization of distinct pieces of information, or the binding among them (the so-called the binding problem), must be a central issue. If we take the dynamic viewpoint, on the other hand, the binding problem might not be a real problem but simply a *pseudo*-problem, because in this case information representation is dynamically realized as a whole, based on the spatio-temporal organization of the network.

Finally, it is interesting to note the similarity of the chaotic aspects of the brain we have studied with the notion of *dynamic equilibrium* hypothesized by Ramachandran (1998). Ramachandran found evidence of drastic changes of "functional modules," which agree with the concept of a dynamic brain. In a dynamic equilibrium state, there is a time dependence of the states of neurons or neuron as-

semblies, as determined by the states of neighboring neurons. Consideration of this concept requires that we change the interpretation of a "functional map." The term "dynamic equilibrium" is self-contradictory, since an equilibrium state cannot be dynamic, as no net flow of energy or matters exists. The implication of the term "dynamic equilibrium" is not, however, inconsistent with our assertions.

ACKNOWLEDGMENTS

The author would like to express his sincere thanks to Péter Érdi for valuable comments on the organization of the manuscript. He would also like to thank Péter Érdi, Walter Freeman, Ad Aertsen, Leslie Kay, George Kampis, and the other members of the Japanese gang of five, Hiroshi Fujii, Minoru Tsukada, Shigetoshi Nara, and Kazuyuki Aihara, for stimulating discussions on the dynamic brain. This work is partially supported by a Grant-in-Aid No. 10440054 for scientific research on priority areas (A) System Theoretical Understanding of Higher Brain Function, No. 12210001 on priority areas (C) Advanced Brain Science Project, and No. 12834001 on Basic Research (C) Science of Complex Systems from the Ministry of Education, Culture, Sports, Science, and Technology, Japan.

Appendix

Chaotic dynamics associated with inference processes

In this appendix, we briefly describe the recent developments in studies on the relation between dynamical systems and logic, in particular the relation between chaotic behavior and deductive inference processes (Basti & Perrone 1992; 1995; Grim 1993; Nicolis & Tsuda 1985).

The dynamical systems studies whose purpose was to relate the neural activity to inference processes have been highlighted since the cybernetics studies of McCulloch and Pitts (1943).⁴ They adopted classical logic, and used a so-called "formal neuron," which is now called a "McCulloch-Pitts neuron," as a dynamical device to simulate "thought." A neural network consisting of neurons of this type of can carry out a universal computation in the sense of Turing. In order to capture the complexity underlying inference processes, however, it seems that we need more complex dynamical systems that provide a basis for *analog* computations and also a method of generating "symbols" out of dynamic behavior. For this purpose, we adopted *Tukasiewicz logic*, which is defined on a continuous space of truth values. Using this type of logic, we formulated several dynamical constructs, including a *meta-dynamical system*, which is defined as a set of dynamical transformations of a function whose arguments are dynamical variables. (For further discussion, see below and Tsuda & Tadaki [1997]. Also see Kataoka & Kaneko [2000a; in press b] for a model of meta-dynamics referred to as a [mathematical] functional map.)

We are concerned with neural activity which is assumed to represent mental states. We assume that such neural activity can be represented by vectors. In our theory, "true" and "false" are represented by orthonormal vectors, which thus span a subset of two-dimensional space represented by a unit square. We consider a projection of neural vectors into this two-dimensional space. The component of such a projected vector in the direction of "truth" represents the truth value of the corresponding neural activity (see also Mizraji & Lin 1997). This truth value can be regarded as a dynamical variable in the case of dynamic neural activity.

Taking into account the successive processes of the logical transformation from a *premise* to a *consequence* and the substitution of this *consequence* for the subsequent *premise*, one may describe an inference process as a dynamical system (Grim 1993; Mar & Grim 1991). In the framework employing such processes formulated by McCulloch and Pitts (1945) and recently developed by Mar and Grim (1991), and Grim (1993), a contradictory statement is represented by a limit cycle, while a consistent and

self-referential statement is represented by chaos (see also Nicolis & Tsuda 1985). This formulation includes the idea that since a person's capability for self-reference enables him or her to carry out self-reflective action, such a capability seems to guarantee at least the capability of deductive inference. It is reasonable that chaos would emerge in such a process, and this is an assertion of Nicolis and Tsuda, and also an assertion of Grim and Mar. In all theories mentioned above, the direction of scalar projection remains undetermined. In the brain, this direction surely depends on awareness and attention. Its determination is believed to be related to intentionality (Basti & Perrone 1995; Freeman 1995a; 1995b; 1999), but such considerations are beyond the scope of the present theory.

In the manner discussed above, deductive inference processes can be described by a certain class of chaotic dynamical systems. In any given case, this class is determined by the type of presupposed logic. On the other hand, the brain describes the dynamics of the real world surrounding it, and such a description itself must be dynamic. We have attempted to formulate such a description (Tsuda & Hatakeyama 2001; Tsuda & Tadaki 1997). In our formulation, the dynamics of the description are functional dynamics, like those briefly mentioned above. In an extreme case, these functional dynamics possess a fixed point, which implies the existence of a fixed description, independent of the environmental dynamics. This description may be expressed as an "autistic state." In another extreme, unrealistic case, the functional dynamics are identical to the environmental dynamics. In this case, the brain actually copies the dynamics of the environment. The dynamics exhibited by models of machine learning represent such copies.

The actual description generated by the brain should be somewhere between these two extreme cases. If such a description of dynamics follows Lukasiewicz logic, the functional dynamics will be chaotic (Tsuda & Tadaki 1997). Such a functional dynamical system can be compared with the chaotic dynamical system with fuzzy distributions proposed by Grim (1993).

Recently, this manner of thinking has led us to the study of a dynamical description of *sylogism*. (Actually it is better to refer to this as *modus ponens* as it is treated as a separation rule.) We have constructed a theory describing tasks performed in cognitive experiments (Tsuda & Hatakeyama 2001). This theory can also be applied to experiments in which one investigates the correlation between deductive inference processes and internal neuronal dynamics measured as the neural activity at the behavioral level. Interpreting logic in terms of dynamical systems thus should be fruitful as a complement to studies of the emergence of logic from dynamic behavior.

Technical Appendix

1. Order parameters and macro-variables

The term "order parameters" originally appeared in studies of phase transitions in condensed matter physics. These order parameters are used to capture the behavior of a macroscopic ordered state emerging from large fluctuations in a critical regime. For instance, in ferromagnetic materials, in the absence of an external magnetic field the magnetic moment of each atom is randomly distributed above the Curie temperature, so that the net (average) magnetic moment is zero, while below the Curie temperature, a nonzero net magnetic moment appears due to the spontaneous cooperative behavior of atoms. The order parameter used for such a system is defined as the net magnetic moment, which indicate the degree of order. In an equilibrium state, this order parameter is a constant. In relaxation processes from near-equilibrium states, the time evolution of an order parameter is expressed by an evolution equation. The use of such equations can be extended to the case of ordered motion in far-from-equilibrium states and also to the case of many order parameters.

An ordered state can be described by a few degrees of freedom

(a few macro-variables), which emerge in the evolution of the system out of many degrees of freedom. These few degrees of freedom are called "order parameters." This concept has been extended to transitions and bifurcations in far-from-equilibrium systems. Haken formulated the slaving mode principle (regarding the behavior of such systems), which is mathematically equivalent to the center manifold theorem. This principle asserts that order parameters (slaving modes) enslave the remaining modes (slaved modes) (see for example Haken 1983). Qualitatively, the manner of thinking employed in this context is that we describe a total system only in terms of its slow motion behavior, eliminating fast motion, and we do this by defining order parameters as the variables governing the slow motion on the center manifold. It should be noted that "slow" and "fast" are used here in a relative sense. In reaction-diffusion systems, for instance, where spatio-temporal organization is taken into account, there is no clear distinction between slow and fast modes. In such a case, by taking into account the diffusion term too as a perturbation, one can extract the macro-variables describing gentle fluctuations.

Because the center manifold theorem (or the slaving mode principle) does not apply to the case of chaotic motion, the macro-variables describing chaotic motion cannot be used as order parameters. In chaotic motion, there exist both "macro-modes," represented by low-frequency components, and "micro-modes," represented by high-frequency components. Hence, it might seem that after rescaling time an "order parameter" would emerge. In chaotic motion, however, there is no clear boundary in frequency space that distinguishes a low-frequency behavior from high-frequency behavior, because of the continuous nature of the spectrum. We note, however, that in chaotic itinerancy, the slow motion exhibited around attractor ruins seems to be distinguishable from the fast motion associated with transitions among ruins. We believe it is important to resolve this conceptual discrepancy.

2. Attractors in the conventional sense and the Milnor sense

Attractors have been defined by using the concept of *attracting sets*. Let X be a compact, or at least finite dimensional, smooth manifold. Let the development of orbits in phase space be given by a continuous map or a diffeomorphism $\phi : X \rightarrow X$. For a set A , the trapping region $N \supset A$ is defined as the region satisfying $A \subset \phi(N) \subset N$. A set A is called an attracting set when

$$\bigcap_{i=0}^{\infty} \phi^{(i)}(N) = A, \text{ where } \phi^{(i)} \text{ is the } i\text{-th iteration of } \phi \text{ and } \cap \text{ represents set intersection.}$$

An attractor is an attracting set, but an attracting set is not necessarily an attractor. We call a set A an attractor if it is an attracting set and $\phi|_A$ is topologically transitive, so that A cannot be separated into subsets by ϕ . Therefore, all points in the trapping region of an attractor are absorbed, or at least approach the attractor. In other words, any point in this neighborhood approaches the attractor as time (or the number of iterations) goes to infinity. Thus an attractor is a topological concept.

Milnor (1985) defined an attractor from another viewpoint, in which both topological and measure-theoretic concepts play roles. Here we give this definition. Let ρ be a measure equivalent to the Lebesgue measure on X . A compact invariant set α is called a (minimal) Milnor attractor if the following hold: (1) The basin of attraction $B(\alpha)$ of α has a positive ρ -measure, that is, $\rho(B(\alpha)) > 0$. (2) There does not exist a proper closed subset α' satisfying

$$\rho(B(\alpha)/B(\alpha')) = 0$$

According to this definition, a Milnor attractor can possess an unstable manifold.

Many definitions of attractors have been proposed from various points of view in which different properties are emphasized. (See Buescu 1997 for detailed discussion on various attractors, including Milnor attractors.)

3. Attractor ruin

We define an attractor ruin as that which remains after the collapse of a Milnor attractor. If there is no such collapse, the asymptotic behavior of the system is not transitory, but rather the behavior corresponding to the Milnor attractor. Thus for the emergence of itinerant behavior another instability is necessary.

4. Chaotic itinerancy

The mathematical study of chaotic itinerancy has only recently begun, and for this reason, its definition has not yet been established. After the present author, together with Ikeda and Kaneko (Kaneko & Tsuda 1996; 2001) found complex but ordered itinerant behavior in a variety of high-dimensional dynamical systems, and we recognized such behavior as possessing common characteristics, we considered the analogy between such behavior and that expected to appear in two interacting subsystems, one of which possesses many more degrees of freedom than the other. In such a situation, it is possible that the smaller subsystem would reach a certain stable state, influenced by the larger subsystem, but through the feedback from the smaller subsystem to the larger one, the state of the larger subsystem may change. As a result, the stability of the smaller subsystem could also change. Such interaction seems to allow the appearance of a slow transition among “quasi-stable states” in the smaller subsystem. Phenomenologically, such transitions are often observed as being history dependent or as process dependent.

Another important characteristic we commonly found is the appearance of many zero- or near-zero-Lyapunov exponents.

I introduced in the text one possible mathematical mechanism of chaotic itinerancy. Through this mechanism, the entire phase space is decomposed into several subspaces, and in each subspace the dynamical orbits are attracted to an attractor ruin, as characterized by the negative tangential Lyapunov exponents defined within each subspace. However, in a direction normal to the subspace the dynamical orbits are repelled from such a ruin, as characterized by the positive normal Lyapunov exponents.

5. Cantor sets

A typical Cantor set, called a “ternary set” or a “middle-third set,” can be constructed by repeating the procedure of dividing a closed interval equally into three, and removing the middle open set.

Let us consider the construction of such a Cantor set from the unit closed interval $I = [0,1]$. The set removed in the first step of the procedure is the middle open interval $(1/3,2/3)$, and thus the remaining intervals are the closed intervals $I_{11} = [0,1/3]$ and $I_{12} = [2/3,1]$. At the n -th step of the procedure, 2^n closed intervals I_{ni} ($i = 1, 2, \dots, 2^n$) are obtained. Then, the Cantor set C is defined by $C = \bigcap_{n=1}^{\infty} C^{(n)}$, where $C^{(n)} = \bigcup_{i=1}^{2^n} I_{ni}$. The Cantor set can also be represented by a set of points in I whose position is represented by $x = \sum_{n=1}^{\infty} \frac{p_n}{3^n}$ where $p_n = 0$ or 2 for each n , hence comes the name ternary set.

The Cantor set is thus the closure of a set of countably infinite number of endpoints of subintervals. In other words, the Cantor set consists of a countably infinite number of uncountable sets on a bounded interval. If one measures this set with a scale of dimension zero, that is, a point, one concludes it has an infinite “volume.” On the other hand, if one measures it with a scale of dimension one, one concludes it has zero “volume.” It is thus reasonable to think that there is some appropriate scale in terms of which this set has a finite “volume.” If such a scale actually exists, it should have “fractal” (noninteger) dimension. The dimension of this scale is considered the dimension of the set itself. In fact, the Cantor set does have a noninteger dimension. An effective method to intuitively understand such an infinite set is to follow the procedure.

The Cantor set is thus the closure of a set of countably infinite number of endpoints of subintervals. In other words, the Cantor set consists of a countably infinite number of uncountable sets on a bounded interval. If one measures this set with a scale of dimension zero, that is, a point, one concludes it has an infinite “volume.” On the other hand, if one measures it with a scale of dimension one, one concludes it has zero “volume.” It is thus reasonable to think that there is some appropriate scale in terms of which this set has a finite “volume.” If such a scale actually exists, it should have “fractal” (noninteger) dimension. The dimension of this scale is considered the dimension of the set itself. In fact, the Cantor set does have a noninteger dimension. An effective method to intuitively understand such an infinite set is to follow the procedure.

method to intuitively understand such an infinite set is to follow the procedure.

In the main text, we did not restrict ourselves to the above described ternary Cantor set, and actually addressed the Cantor set in a more general sense. The Cantor set is generally defined as a *closed, totally disconnected, and perfect* set. When a set does not contain any finite intervals, it is termed *totally disconnected*. When every element of a set is an accumulation point, it is termed *perfect*.

6. The SCND attractor

The SCND (singular-continuous but nowhere-differentiable) attractor can be represented by the graph of a SCND function. The SCND function, first studied by Rössler et al. (1992), was defined by Tsuda and Yamaguchi (1998) in terms of singular continuity, and differentiability on the Cantor set (Tsuda & Yamaguchi 1998), where definitions are given below. The following definitions are given for the ternary Cantor set, but they can be extended to the more general case.

Definition: Singular continuity

For the union of intervals I_{ni} ($i = 1, 2, \dots, 2^n$) remaining at each step n in the process of constructing a Cantor set C , one can define a continuous function $h_n(x)$ in each interval I_{ni} , namely for $x \in I_{ni}$ for each i . If the functional series $\{h_n(x)\}$ uniformly converges, then we call its limit $h(x)$, with $x \in C$, a singular-continuous function.

Definition: Differentiability on the Cantor set

The set of right endpoints C_r and the set of left endpoints C_l of subintervals I_{ni} for every i and n are subsets of the Cantor set. That is, $C \supset C_r \cup C_l$. For each $x \in C$, the quotient $\delta_n(x) \equiv \frac{h(y_n) - h(x)}{y_n - x}$

is defined, where the series $\{y_n\}$ consisting of endpoints is a monotonically convergent series to x . Then, since Dini's derivatives always exist, if we allow $\pm \infty$, one can define $D^*(x) \equiv \limsup_{n \rightarrow \infty} \delta_n(x)$

and $D_*(x) \equiv \liminf_{n \rightarrow \infty} \delta_n(x)$, where $*$ denotes a symbol “plus” or

“minus.” For $y_n < x$, Dini's left derivatives $D^-(x)$ and $D_-(x)$ are defined for $x \in C_r$. Similarly, for $y_n > x$, Dini's right derivatives $D^+(x)$ and $D_+(x)$ are defined for $x \in C_l$. If for any convergent series, $D^-(x) = D_-(x)$ for $\forall x \in C_r$, and $D^+(x) = D_+(x)$ for $\forall x \in C_l$, then we call $h(x)$, $x \in C$, a differentiable function on the Cantor set.

If for some function the above condition for differentiability is not satisfied at any value of $x \in C_l \cup C_r$, we say that it is a nowhere-differentiable function on the Cantor set.

7. Contracting map under the Hausdorff metric

We dealt with contracting maps in sections 3.6 and 4. The contraction and expansion of a map are defined in terms of some metric. We adopted the Hausdorff metric. Now, let D be a set, which for our purpose is a phase space. Let $H(D)$ be the collection of all nonempty closed subsets of D . For every A and $B \in H(D)$, the Hausdorff metric is defined as:

$$d_H(A, B) := \inf\{\epsilon > 0 | N_\epsilon(A) \supset B, \text{ and } N_\epsilon(B) \supset A\},$$

where $N_\epsilon(\bullet)$ is an ϵ -neighborhood of \bullet .

NOTES

1. If the instability in the normal direction is too strong, the system's overall behavior becomes fully-developed turbulence.

2. These authors used the term “fractal” figures in reference to represent complex figures including concave contours and/or nonsmooth curves, but this name is misleading. The figures they defined are not literally “fractal.” Even though a procedure to produce fractal figures was used, the figures they used are produced by using only one or two iteration(s). The fractal, which was de-

fractal, defined originally by Mandelbrot, must have a noninteger dimension, so that it contains infinitely many copies with various sizes of reduction of the whole figure or its parts, whose reduction is realized by affine transformations.

3. This is the dimension of the support of the attractor.

4. George Boole is, as far as we know, the first person to notice the deep relation between dynamics (recursive maps) and logic, but he used only fixed points (0 and 1) of the dynamical system, $x_{n+1} = x_n^2$, solving the algebraic equation $x = x^2$. Here, x may represent, for instance, "being blue," and the algebraic equation may imply equivalence between the two expressions "being blue" and "being blue and blue." This equivalence class can be expressed as the fixed points of the above dynamical system (Boole 1854).