



HOKKAIDO UNIVERSITY

Title	Genetic recombination at different points in the Npro-coding region of bovine viral diarrhea viruses and the potentials to change their antigenicities and pathogenicities
Author(s)	Kameyama, K.; Sakoda, Y.; Tamai, K. et al.
Citation	Virus Research, 116(1-2), 78-84 https://doi.org/10.1016/j.virusres.2005.08.016
Issue Date	2006-03
Doc URL	https://hdl.handle.net/2115/6115
Type	journal article
File Information	VR116(1-2).pdf



Genetic recombination at different points in the N^{pro}-coding region of bovine viral diarrhea viruses and the potentials to change their antigenicities and pathogenicities

K. Kameyama ^a, Y. Sakoda ^a, K. Tamai ^a, M. Nagai ^b, H. Akashi ^c, H. Kida ^{a,*}

^a Laboratory of Microbiology, Department of Disease Control, Graduate School of Veterinary Medicine, Hokkaido University, Sapporo 060-0818, Japan

^b Ishikawa Hokubu Livestock Hygiene Service Center, Tatsuruhama, Ishikawa 929-2126, Japan

^c Department of Veterinary Microbiology, Graduate School of Agricultural and Life Sciences, The University of Tokyo, Bunkyo, Tokyo 113-8657, Japan

Corresponding author: H. Kida

Correspondence address: Laboratory of Microbiology, Department of Disease Control, Graduate School of Veterinary Medicine, Hokkaido University, Kita 18 Nishi 9, Sapporo 060-0818, Japan

Tel.: +81-11-706-5207; fax: +81-11-706-5273.

E-mail address: kida@vetmed.hokudai.ac.jp (H. Kida)

Abstract

Cytopathogenic (cp) bovine viral diarrhea virus (BVDV) strain KS86-1cp was isolated from a cow persistently infected with non-cytopathogenic (ncp) BVDV strain KS86-1ncp after development of mucosal disease by superinfection with cp BVDV strain Nose. Cp BVDV strains 799cp and 839cp were also isolated from independent cattle that developed mucosal disease by superinfection with cp BVDV KS86-1cp. In the present study, genetic analysis revealed that the genes of cp BVDV strains 799cp and 839cp were chimeras between the genes of the persisting ncp BVDVs and that of superinfecting KS86-1cp. The genetic recombination that generates 799cp occurred between the identical points in the N^{pro} gene region, whereas genetic recombination that generates 839cp occurred between different points in the N^{pro} gene region. Both 799cp and 839cp were inherited Jiv gene of KS86-1cp strain and envelope protein genes of the persisting viruses. In addition, neutralization test disclosed that antigenicities of 799cp, 839cp, and KS86-1cp were also similar to each persisting virus. These findings indicate that exogenous cp BVDV containing insertion of Jiv gene in the 5-terminal region can induce genetic recombination with the original ncp BVDV at different points in the N^{pro} gene region, and those viruses have high potential to change those antigenicities and pathogenicities by RNA recombination.

Keywords: Bovine viral diarrhea virus; genetic recombination; Jiv

1. Introduction

Bovine viral diarrhoea virus (BVDV) belongs to the genus *Pestivirus* of the family *Flaviviridae* (Heinz et al., 2000). The BVDV genome consists of a positive-stranded RNA molecule of approximately 12.3 kb and contains one large open reading frame (ORF) flanked by 5' and 3' untranslated regions (UTRs) (Meyers and Thiel, 1996; Thiel et al., 1996). This ORF encodes a polyprotein that is processed by viral and cellular proteases, giving rise to the 11-12 mature viral proteins (Meyers and Thiel, 1996). The first third of the ORF encodes a nonstructural autoprotease and four structural proteins, while the 3' part of the RNA genome codes for the other nonstructural proteins (Meyers and Thiel, 1996; Thiel et al., 1996). On the basis of the nucleotide sequence of the 5' UTR, BVDV isolates are divided into genotype 1 (BVDV-1) and genotype 2 (BVDV-2). BVDVs belonging to BVDV-2 are antigenically different from those of BVDV-1 (Nagai et al., 2001; Pellerin et al., 1994). Furthermore, Shimizu et al. (1989a; 1989c) divided BVDV-1 into three serogroups on the basis of antigenicity: group N (strain Nose type), group K (strain KS86-1cp type), and another group.

In pregnant cows infected with BVDV, transplacental infection occurs frequently, resulting in various congenital abnormalities of fetuses depending on the stage of gestation. If infection with non-cytopathogenic (ncp) BVDV occurs between 80 and 100 days of gestation, the newborn animals may become tolerant to BVDV antigens and remain persistently infected for life (Lindenbach and Rice, 2001). Cattle persistently infected with BVDV may succumb to fatal mucosal disease. In the case of an animal exhibiting mucosal disease, both ncp and cytopathogenic (cp) BVDV can be isolated (McClurkin et al., 1985). Molecular analyses of several BVDV pairs indicated that the cp

BVDVs can evolve from the respective ncp BVDVs by RNA recombination (Meyers and Thiel, 1996). Insertion of cellular sequences is a type of RNA recombination that generates cp BVDVs. Most of these insertions were located in NS2 or NS3 gene (Baroth et al., 2000; Becher et al., 1998; Becher et al., 2002; Meyers et al., 1998; Meyers and Thiel, 1996; Qi et al., 1998). It has been suggested and reported that diverse recombinations have occurred around NS3 gene of the viral genomes which contain cellular sequences (Becher et al., 2001; Fricke et al., 2001; Fritzemeier et al., 1997; Ridpath and Bolin, 1995). Recently, insertions of Jiv (previously designated as cINS) were detected in the region between N^{pro} and C genes (Muller et al., 2003; Nagai et al., 2003), and the recombination between the identical points (homologous recombination) occurred at directly downstream of Jiv gene (Nagai et al., 2003). However, no other analysis was reported for the position of genetic recombination at the N-terminal region of polyprotein in contrast to the NS2-3 region. In this paper, we describe the genetic recombination at different positions in the N^{pro} region between original ncp BVDV and superinfecting cp BVDV containing cellular insertion in the N-terminal region of polyprotein and serological relation of those viruses.

2. Materials and methods

2.1. Viruses and Cells

BVDV strains KS86-1cp, KS86-1ncp, and Nose were kindly provided by Dr. M. Shimizu (National Institute of Animal Health, Japan). KS86-1ncp (previously designated as 1/NC/0) and Nose were isolated from naturally infected cattle (Kodama et al., 1974; Shimizu et al., 1989b). KS86-1cp (previously designated as 1/C/32) was isolated from a calf persistently infected with KS86-1ncp and suffering from mucosal disease after experimental superinfection with cp BVDV strain Nose (Shimizu et al., 1989b). BVDV strains 799cp, 799ncp, 839cp, and 839ncp were kindly provided by Dr. H. Sentsui (National Institute of Animal Health, Japan). The ncp BVDV strains 799ncp and 839ncp were isolated from naturally infected cattle. The cp BVDV strains 799cp and 839cp were isolated from these cattle after development of mucosal disease upon experimental superinfection with KS86-1cp (Sentsui et al., 2001). Viruses were propagated in primary bovine testicle (BT) cells. BT cells were grown in Eagle's minimum essential medium supplemented with 0.295 % tryptose phosphate broth (Difco), 5 % horse serum (Invitrogen), and 5 % BVDV-free fetal calf serum (Mitsubishi Pharma).

2.2. RNA extraction and reverse transcription-polymerase chain reaction (RT-PCR)

Viral RNA was extracted from BT cells that had been inoculated with each BVDV strain at an m.o.i. of 1, using TRIzol Reagent (Invitrogen) in accordance with the manufacturer's protocol. Viral genes were amplified with an RNA LA PCR Kit (AMV) ver.1.1 (TaKaRa) and a thermal cycler PTC-200 (MJ Research). PCR products were examined by agarose gel electrophoresis. The

primers used for RT-PCR in the present study were sense primer 324 (Vilcek et al., 1994), sense primer 864F (Nagai et al., 2003), antisense primer 1124R (Nagai et al., 2003), sense primer E1-F (5'-CAAGAGTAAGACATGGTTTG), sense primer 1429F (5'-CGCCATGAGTGGAACAAG), sense primer 3306F [5'-ATGCCTTGCAA(A/G)CCATATGA], sense primer 4010F [CTGATG(A/G)TTAG(C/T)TATGTGA], antisense primer E2-R (5'-TGTGGTATATGAGTATGAC C), antisense primer 4250R [5'-AAGTCGGCCCA(C/T)A(A/G)GGT], sense primer P80 (Pellerin et al., 1995), antisense primer 6365R (Nagai et al., 2004), antisense primer 8282R [GTACCCA(A/G)CA(A/G)TCCATCACT], sense primer KS12828-F (5'-TGACAGAGGTTACA CAGTAC), and antisense primer Nose13137-R (5'-CGGG TGTATCCTCATACAGC).

2.3. Cloning, sequencing, and genetic analysis

PCR products were cloned into plasmids using the pGEM-T vector system (Promega). Nucleotide sequences were determined from these plasmids using an automated DNA sequencer CEQ2000 (Beckman Coulter) in accordance with the Dye Terminator Cycle Sequence Chemistry Protocol (Beckman Coulter). Sequence data were analyzed using GENETYX-WIN version 4.0.6 (Software development) with the nucleotide sequences of BVDV strains KS86-1ncp and KS86-1cp (DDBJ accession No. AB078950 and AB078952) (Nagai et al., 2003).

2.4. SDS-PAGE and Western blot analysis

SDS-PAGE and Western blot analysis were performed by the methods of Laemmli (1970) and Towbin et al. (1979). At 48 h postinfection, BT cells infected with BVDVs were lysed with sample

loading buffer (0.1 M Tris-HCl, 4 % SDS, 12 % 2-mercaptoethanol, 20 % glycerol, and Bromophenol blue) and separated by 10 % SDS-polyacrylamide gel electrophoresis. Separated proteins were then electrophoretically transferred to an Immobilon-P transfer membrane (Millipore). The membrane was treated with 5 % non-fat milk, then treated with monoclonal antibody (MAb) 46/1 against recombinant NS3 protein made by the general method of Kida et al. (1982), and finally treated with peroxidase-labelled goat anti-mouse IgG (Bio-Rad). NS3 protein was detected with Lumi-light western blotting substrate (Roche) and exposure to Hyperfilm ECL (Amersham).

2.5. Cross-neutralization test

Cross-neutralization test based on the immunoperoxidase method was carried out according to the instructions of the OIE manual (Drew, 2004). Serial twofold dilutions were made from starting dilution of 1:2, and neutralization of the viruses was detected by immunoperoxidase method. In this method, microplates were fixed by incubating at 75 °C for 1 hour, and anti-NS3 MAb 46/1 which was mentioned above was used for antigen detection.

3. Results

3.1. Amplification of viral genes between 5' UTR and C

Viral genes between the 5' UTR and C of KS86-1ncp, KS86-1cp, 799ncp, 799cp, 839ncp, and 839cp were amplified by RT-PCR using primer set 324/1124R. The PCR products of 799ncp and 839ncp were approximately 1 kb in length, which was equivalent to that of KS86-1ncp (1,036 bp). On the other hand, those of 799cp and 839cp (about 2 kb in length) were similar to that of KS86-1cp (1,932 bp) (Fig. 1).

3.2. Genome structure of 799cp strain in comparison with 799ncp and KS86-1cp

The genome structure of 799cp was determined by the comparison with those of 799ncp, KS86-1cp, and 799cp (Fig. 2A). The viral genes between C (or C') and NS4A were amplified by RT-PCR using a primer sets 864F/4250R, 4010F/6365R, P80/8282R. The genome structure between the 5' UTR and NS4A of 799ncp was 5' UTR, N^{pro}, C, E^{ms}, E1, E2, p7, NS2, NS3, and NS4A the same as that of the standard BVDVs. That of KS86-1cp was 5' UTR, N^{pro}, C, Jiv, N^{pro'}, C', E^{ms}, E1, E2, p7, NS2, NS3, and NS4A as reported by Nagai et al. (2003). The genome structure of 799cp was 5' UTR, N^{pro}, C, Jiv, N^{pro'}, C', E^{ms}, E1, E2, p7, NS2, NS3, and NS4A with insertion of the Jiv gene and duplication of the N^{pro} and C genes (N^{pro'} and C'), which was similar to that of KS86-1cp, and with incomplete C and N^{pro'} genes. In 799cp, the C gene was 228 nucleotides (nt) short at the 3' terminus and N^{pro'} gene was 15 nt short at the 5' terminus. The nucleotide sequences of the three BVDVs (799cp, 799ncp, and KS86-1cp) were then compared. The nucleotide sequences of the 5' UTR, N^{pro}, C, Jiv, and 5' terminal 234 nt of N^{pro'} of 799cp were almost identical

to those of KS86-1cp; on the other hand, the sequences of the 3' terminal 255 nt of N^{pro}, C', E^{ms}, E1, E2, p7, NS2, NS3, and NS4A were almost identical to those of 799ncp. These data indicate that 799cp is a genetic chimera resulting from homologous RNA recombination between N^{pro} of 799ncp and N^{pro} of KS86-1cp. The number of identical nucleotides at the putative RNA recombination point was two (Fig. 2A).

3.3. Genome structure of 839cp strain in comparison with 839ncp and KS86-1cp

The genome structure of 839cp was also determined by comparison with those of 839ncp and KS86-1cp (Fig. 2B). The viral genes between C (or C') and NS4A were also amplified by RT-PCR using the same primer sets that used for 799ncp. Like the genome structure of 799ncp, that of 839ncp between the 5' UTR and NS4A was the standard genome structure of BVDV (5' UTR, N^{pro}, C, E^{ms}, E1, E2, p7, NS2, NS3, and NS4A). That of 839cp was 5' UTR, N^{pro}, C, Jiv, N^{pro}, N^{pro}, C', E^{ms}, E1, E2, p7, NS2, NS3, and NS4A with another duplication of the N^{pro} gene (N^{pro}) in addition to the insertion of the Jiv gene and duplication of the N^{pro} and C genes (N^{pro} and C') of KS86-1cp and 799cp. In the genes of 839cp, C, N^{pro}, and N^{pro} were incomplete, the C gene was 228 nt short at the 3' terminus, the N^{pro} gene was 15 nt and 234 nt short at the 5' terminus and the 3' terminus, respectively, and the N^{pro} gene was 24 nt short at the 5' terminus. We then compared the nucleotide sequences of 839cp, 839ncp, and KS86-1cp. The nucleotide sequences of the 5' UTR, N^{pro}, C, Jiv, and N^{pro} of 839cp were almost identical to those of KS86-1cp. On the other hand, the sequences of N^{pro}, C', E^{ms}, E1, E2, p7, NS2, NS3, and NS4A were almost identical to those of 839ncp. The present data indicate that 839cp is a genetic chimera generated by RNA

recombination between N^{pro} of 839ncp and N^{pro} of KS86-1cp. In addition, this recombination occurred between different positions of the two N^{pro} genes (N^{pro} of 839ncp and N^{pro} of KS86-1cp). The number of the identical nucleotides at the putative RNA recombination point was four (Fig. 2B).

On the basis of partial nucleotide sequences of 3' UTR of 799ncp, 799cp, 839ncp, and 839cp, it is unlikely that additional recombinations occurred in the genome of 799cp and 839cp (data not shown).

3.4. Cleavage of NS2-3 protein of BVDV in the infected cells

Cleavage of NS2-3 protein in the cells infected with KS86-1ncp, KS86-1cp, 799ncp, 799cp, 839ncp, and 839cp was investigated by Western blot analysis. Using anti-NS3 MAb, a protein of approximately 120 kDa (NS2-3) was detected in the cells infected with any of these BVDV strains. In addition, a protein of approximately 80 kDa (NS3) was also detected only in the cells infected with cp BVDVs (KS86-1cp, 799cp, and 839cp) (Fig. 3).

3.5. Serological analysis of the BVDV strains

The antigenic properties of BVDV strains were compared by cross-neutralization tests (Table 1). The 799cp, 839cp, and KS86-1cp strains were neutralized by the antiserum to the persistently infecting virus (799ncp 839ncp, or KS86-1ncp strain). On the other hand, KS86-1cp and KS86-1ncp strains were hardly neutralized by antiserum to Nose strain, and 799cp, 799ncp, 839cp, and 839ncp strains were hardly neutralized by antiserum to KS86-1cp strain. These results suggest that antigenicity of KS86-1cp strain is similar to that of persisting ncp BVDV strain KS86-1ncp, and

different from that of superinfecting cp strain Nose. Likewise, antigenicities of 799cp and 839 cp are similar to those of 799ncp and 839ncp, and different from that of superinfecting KS86-1cp strain.

4. Discussion

The BVDV strains Nose and CP8 are field isolates of cp type with Jiv sequences located in the N-terminal region of polyprotein (Muller et al., 2003; Nagai et al., 2003). KS86-1cp was generated by homologous recombination between Nose and KS86-1ncp at directly downstream of the Jiv gene (Nagai et al., 2003; Shimizu et al., 1989b). The cp BVDV strains 799cp and 839cp were isolated from the cattle persistently infected with ncp BVDV strains 799ncp and 839ncp that developed mucosal disease after experimental superinfection with KS86-1cp (Sentsui et al., 2001). In the present study, nucleotide sequences of 799cp and 839cp were systematically compared with the original ncp BVDVs (799ncp and 839ncp) and superinfecting KS86-1cp strain. The results indicate that 799cp and 839cp were generated by homologous or nonhomologous RNA recombination between N^{pro} genes of persistently infecting ncp BVDV and N^{pro} genes of superinfecting cp BVDV (Fig. 2). As a result, 799cp and 839cp acquired the cellular Jiv and the same antigenicity as the original ncp BVDVs. To keep these acquired characters and infectivity, homologous recombination might occur at any point in N^{pro} (N^{pro}) and C (C') gene. Although nonhomologous recombination could occur at any point in N^{pro} and C' of KS86-1cp strain, recombination point of original ncp BVDV in this system should be restricted to N-terminus of N^{pro} to maintain autoprotease activity. Since the NS3 protein is detected in the cells infected with 799cp and 839cp (Fig. 3), processed protein units C-Jiv-N^{pro} and C-Jiv-N^{pro}-N^{pro} that derived from N-terminus region of viral polyproteins might stimulate NS2-3 cleavage and pathogenicity *in vitro* and *in vivo* according to the previous results (Muller et al., 2003; Rinck et al., 2001).

Fricke et al. (2001) showed that a set of BVDVs that had gene deletions and duplications at

various points was generated in the body of persistently infected cattle before the onset of mucosal disease. In our case, it was considered that the various recombinants of BVDV were generated between endogenous ncp BVDV and exogenous cp BVDV after superinfection in the cattle persistently infected. In the cases of mucosal disease which is caused by strains 799cp and 839cp, the periods for these mucosal disease onsets after the superinfection are 30 and 33 days. These are shorter than the periods of other late-onset cases [from 4 weeks to several years (Brownlie and Clarke, 1993); 14 or 41 weeks (Fritzemeier et al., 1995; Fritzemeier et al., 1997); 3 months (Ridpath and Bolin, 1995)]. However, it may be long enough for the selection of appropriate genetic chimera from various variants under the immunological pressure. Thus, it is considered that 799cp and 839cp were selected from BVDV variants based on the antigenicity of each endogenous ncp BVDV. In contrast, the period until the mucosal disease onset was shorter if the superinfecting virus became dominant directly without genomic recombination (21 days in the case of BVDV strain 829cp) (Sentsui et al., 2001).

Each of the recombination points of 799cp and 839cp was not identical to that of KS86-1cp that was shown by Nagai et al. (2003). The most widely accepted model of RNA recombination is template switching of the viral RNA polymerase (Fricke et al., 2001), and base pairing between the nascent strand and the acceptor template may facilitate the reassociation step of template switching (Becher et al., 1999). However, in the present study, (i) nonhomologous recombination, which is clearly disadvantageous with respect to sequence identity, occurred in 839cp, (ii) the identical nucleotide sequences at the putative RNA recombination points of 839cp is short (4 bases) and (iii) the homologous recombination of 799cp did not occur at points with higher identities but at a point

with only two identical nucleotides. These results indicate that template switching may occur at various positions irrespective of the sequence identity. Therefore, the present data partially supports the hypothesis that template switching is influenced to a greater degree by RNA secondary structure than by sequence (Desport et al., 1998; Hajjou et al., 1996).

In the present study, it was revealed that BVDV strains 799cp and 839cp are chimeric viruses generated by RNA recombination between the genome of strain 799ncp or 839ncp and that of strain KS86-1cp. These viruses inherited both envelope genes of the persisting viruses and cell-derived Jiv gene of the strain KS86-1cp. KS86-1cp is the virus isolated from cattle of mucosal disease by superinfection with cp BVDV strain Nose (Shimizu et al., 1989b). It was shown that KS86-1cp is also a chimeric virus with envelope genes of the persistently infecting KS86-1ncp and Jiv gene of superinfecting with Nose (Nagai et al., 2003). Not only the nucleotide sequences but also the antigenicities of 799cp, 839cp, and KS86-1cp were similar to those of 799ncp, 839ncp, and KS86-1ncp, respectively. In contrast, the antigenicities of Nose were different from KS86-1cp and that of KS86-1cp were different from 799cp and 839cp (Table 1). These results indicate that Nose-like cp BVDVs which have insertions of Jiv gene in N^{pro} region have high potential to change its antigenicity by RNA recombination when they were superinfecting to the cattle persistently infecting with ncp BVDVs (i.e. from Nose strain to KS86-1cp strain, from KS86-1cp strain to 799cp and 839cp strains). However, development of mucosal disease due to superinfection of antigenically different cp BVDV has not, to our knowledge, been confirmed in the case of a natural infection. The reason for this may attributed to the difficulty to obtain a set of the viruses composed of persisting virus, superinfecting virus, and virus causing mucosal disease from individual cattle

developing mucosal disease in a natural setting. To understand the molecular basis of mucosal disease, continuous virus isolation from cattle in the field and further analysis of recombination mechanism are required.

Acknowledgements

We thank Dr. M. Shimizu (National Institute of Animal Health, Japan) for providing BVDV KS86-1cp, KS86-1ncp, and Nose strains, and Dr. H. Sentsui (National Institute of Animal Health, Japan) for providing BVDV 799cp, 799ncp, 839cp, and 839ncp strains. We thank A. S. Mweene for checking grammatical errors of the manuscript. Y. Sakoda was supported by Grants-in-Aid for Scientific Research of Young Scientists (B) No. 15780193 from the Ministry of Education, Culture, Sports, Science, and Technology, Japan.

References

- Baroth, M., Orlich, M., Thiel, H.J. and Becher, P. (2000) Insertion of cellular NEDD8 coding sequences in a pestivirus. *Virology* 278(2), 456-466.
- Becher, P., Orlich, M., Konig, M. and Thiel, H.J. (1999) Nonhomologous RNA recombination in bovine viral diarrhea virus: molecular characterization of a variety of subgenomic RNAs isolated during an outbreak of fatal mucosal disease. *J. Virol.* 73(7), 5646-5653.
- Becher, P., Orlich, M. and Thiel, H.J. (1998) Ribosomal S27a coding sequences upstream of ubiquitin coding sequences in the genome of a pestivirus. *J. Virol.* 72(11), 8697-8704.
- Becher, P., Orlich, M. and Thiel, H.J. (2001) RNA recombination between persisting pestivirus and a vaccine strain: generation of cytopathogenic virus and induction of lethal disease. *J. Virol.* 75(14), 6256-6264.
- Becher, P., Thiel, H.J., Collins, M., Brownlie, J. and Orlich, M. (2002) Cellular sequences in pestivirus genomes encoding gamma-aminobutyric Acid (a) receptor-associated protein and Golgi-associated ATPase enhancer of 16 kilodaltons. *J. Virol.* 76(24), 13069-13076.
- Brownlie, J. and Clarke, M.C. (1993) Experimental and spontaneous mucosal disease of cattle: a validation of Koch's postulates in the definition of pathogenesis. *Intervirology* 35(1-4), 51-59.
- Desport, M., Collins, M.E. and Brownlie, J. (1998) Genome instability in BVDV: an examination of the sequence and structural influences on RNA recombination. *Virology* 246(2), 352-361.
- Drew, T. (2004) Bovine Viral Diarrhea, *Manual of Diagnostic Tests and Vaccines for Terrestrial Animals* (mammals, birds and bees). OIE, Paris, pp. 1051-1063.

- Fricke, J., Gunn, M. and Meyers, G (2001) A family of closely related bovine viral diarrhea virus recombinants identified in an animal suffering from mucosal disease: new insights into the development of a lethal disease in cattle. *Virology* 291(1), 77-90.
- Fritzemeier, J., Greiser-Wilke, I., Haas, L., Pituco, E., Moennig, V. and Liess, B. (1995) Experimentally induced "late-onset" mucosal disease--characterization of the cytopathogenic viruses isolated. *Vet. Microbiol.* 46(1-3), 285-294.
- Fritzemeier, J., Haas, L., Liebler, E., Moennig, V. and Greiser-Wilke, I. (1997) The development of early vs. late onset mucosal disease is a consequence of two different pathogenic mechanisms. *Arch. Virol.* 142(7), 1335-1350.
- Hajjou, M., Hill, K.R., Subramaniam, S.V., Hu, J.Y. and Raju, R. (1996) Nonhomologous RNA-RNA recombination events at the 3' nontranslated region of the Sindbis virus genome: hot spots and utilization of nonviral sequences. *J. Virol.* 70(8), 5153-5164.
- Heinz, F.X., Collet, M.S., Purcell, R.H., Gould, E.A., Howard, C.R., Houghton, M., Moormann, R.J.M., Rice, C.M. and Thiel, H.J. (2000) Family *Flaviviridae*. In: M.H.V.v. Regenmortel, C.M. Fauquet, D.H.L. Bishop, E.B. Carstens, M.K. Estes, S.M. Lemon, J. Maniloff, M.A. Mayo, D.J. McGeoch, C.R. Pringle and R.B. Wickner (Eds), *Virus Taxonomy*. Seventh Report of the International Committee on Taxonomy of viruses. Academic press, San Diego, pp. 859-878.
- Kida, H., Brown, L.E. and Webster, R.G (1982) Biological activity of monoclonal antibodies to operationally defined antigenic regions on the hemagglutinin molecule of A/Seal/Massachusetts/1/80 (H7N7) influenza virus. *Virology* 122(1), 38-47.

- Kodama, K., Sasaki, N., Fukuyama, S., Izumida, A. and Ishii, F. (1974) Studies on cytopathogenic bovine viral diarrhea virus recovery, identification, and properties of isolated virus. *Bull. Nippon Vet. Zootech. Coll.* 23, 51-60.
- Laemmli, U.K. (1970) Cleavage of structural proteins during the assembly of the head of bacteriophage T4. *Nature* 227(259), 680-685.
- Lindenbach, B.D. and Rice, C.M. (2001) Flaviviridae. In: D.M. Knipe and P.M. Howley (Eds), *Fields Virology*. Lippincott Williams & Wilkins, Philadelphia, pp. 991-1042.
- McClurkin, A.W., Bolin, S.R. and Coria, M.F. (1985) Isolation of cytopathic and non-cytopathic bovine viral diarrhea virus from the spleen of cattle acutely and chronically affected with bovine viral diarrhea. *J Am Vet Med Assoc* 186, 568-569.
- Meyers, G., Stoll, D. and Gunn, M. (1998) Insertion of a sequence encoding light chain 3 of microtubule-associated proteins 1A and 1B in a pestivirus genome: connection with virus cytopathogenicity and induction of lethal disease in cattle. *J. Virol.* 72(5), 4139-4148.
- Meyers, G. and Thiel, H.J. (1996) Molecular characterization of pestiviruses. *Adv. Virus Res.* 47, 53-118.
- Muller, A., Rinck, G., Thiel, H.J. and Tautz, N. (2003) Cell-derived sequences in the N-terminal region of the polyprotein of a cytopathogenic pestivirus. *J. Virol.* 77(19), 10663-10669.
- Nagai, M., Hayashi, M., Sugita, S., Sakoda, Y., Mori, M., Murakami, T., Ozawa, T., Yamada, N. and Akashi, H. (2004) Phylogenetic analysis of bovine viral diarrhea viruses using five different genetic regions. *Virus Res.* 99(2), 103-113.
- Nagai, M., Ito, T., Sugita, S., Genno, A., Takeuchi, K., Ozawa, T., Sakoda, Y., Nishimori, T.,

- Takamura, K. and Akashi, H. (2001) Genomic and serological diversity of bovine viral diarrhea virus in Japan. *Arch. Virol.* 146(4), 685-696.
- Nagai, M., Sakoda, Y., Mori, M., Hayashi, M., Kida, H. and Akashi, H. (2003) Insertion of cellular sequence and RNA recombination in the structural protein coding region of cytopathogenic bovine viral diarrhoea virus. *J. Gen. Virol.* 84(Pt 2), 447-452.
- Pellerin, C., Moir, S., Lecomte, J. and Tijssen, P. (1995) Comparison of the p125 coding region of bovine viral diarrhea viruses. *Vet. Microbiol.* 45(1), 45-57.
- Pellerin, C., van den Hurk, J., Lecomte, J. and Tussen, P. (1994) Identification of a new group of bovine viral diarrhea virus strains associated with severe outbreaks and high mortalities. *Virology* 203(2), 260-268.
- Qi, F., Ridpath, J.F. and Berry, E.S. (1998) Insertion of a bovine SMT3B gene in NS4B and duplication of NS3 in a bovine viral diarrhea virus genome correlate with the cytopathogenicity of the virus. *Virus Res.* 57(1), 1-9.
- Ridpath, J.F. and Bolin, S.R. (1995) Delayed onset postvaccinal mucosal disease as a result of genetic recombination between genotype 1 and genotype 2 BVDV. *Virology* 212(1), 259-262.
- Rinck, G., Birghan, C., Harada, T., Meyers, G., Thiel, H.J. and Tautz, N. (2001) A cellular J-domain protein modulates polyprotein processing and cytopathogenicity of a pestivirus. *J. Virol.* 75(19), 9470-9482.
- Sentsui, H., Nishimori, T., Kirisawa, R. and Morooka, A. (2001) Mucosal disease induced in cattle persistently infected with bovine viral diarrhea virus by antigenically different cytopathic

- virus. Arch. Virol. 146(5), 993-1006.
- Shimizu, M., Murakami, S. and Satou, K. (1989a) Serological comparison of cytopathogenic and non-cytopathogenic bovine viral diarrhea-mucosal disease viruses isolated from cattle with mucosal disease. Jpn. J. Vet. Sci. 51(1), 157-162.
- Shimizu, M., Satou, K., Nishioka, N., Yoshino, T., Momotani, E. and Ishikawa, Y. (1989b) Serological characterization of viruses isolated from experimental mucosal disease. Vet. Microbiol. 19(1), 13-21.
- Shimizu, M., Watanabe, H., Satou, K. and Murakami, S. (1989c) Antigenic diversity of bovine viral diarrhea-mucosal disease (BVD-MD) viruses recently isolated from persistently infected cattle and mucosal disease, and serologic survey on bovine sera using antigenically different BVD-MD viruses. Jpn. J. Vet. Sci. 51(6), 1115-1122.
- Thiel, H.J., Plagemann, P.G.W. and Moennig, V. (1996) Pestiviruses. In: B.N. Fields, D.M. Knipe and P.M. Howley (Eds), Fields Virology. Lippincott-Raven, Philadelphia, pp. 1059-1073.
- Towbin, H., Staehelin, T. and Gordon, J. (1979) Electrophoretic transfer of proteins from polyacrylamide gels to nitrocellulose sheets: procedure and some applications. Proc. Natl. Acad. Sci. U. S. A. 76(9), 4350-4354.
- Vilcek, S., Herring, A.J., Herring, J.A., Nettleton, P.F., Lowings, J.P. and Paton, D.J. (1994) Pestiviruses isolated from pigs, cattle and sheep can be allocated into at least three genogroups using polymerase chain reaction and restriction endonuclease analysis. Arch. Virol. 136(3-4), 309-323.

Figure legends

Fig. 1. Amplification of BVDV genes between 5' UTR and C using primer set 324/1124R. RT-PCR products derived from KS86-1ncp, KS86-1cp, 799ncp, 799cp, 839ncp, and 839cp using primer set 324/1124R for amplification of the viral genes between 5' UTR and C. The PCR products were separated on a 0.8 % agarose gel and stained with ethidium bromide.

Fig. 2. Genome structures and nucleotide sequences around the putative recombination positions of 799cp (A) and 839cp (B). The white boxes represent genetic regions of persisting ncp BVDV strains 799ncp (A) and 839ncp (B). And the gray boxes represent that of KS86-1cp. The inserted Jiv genes are indicated as striped boxes. Broken lines and arrows indicate the putative RNA recombination points. The nucleotides of putative recombination points are enclosed with lines. Dots indicates identity with the sequences of 799ncp (A) or 839ncp (B). The accession numbers in DDBJ, EMBL, and GenBank of the nucleotide sequence data between the 5' UTR and NS4A gene of 799ncp, 799cp, 839ncp, and 839cp are AB111961, AB111962, AB111963, and AB111964, respectively.

Fig. 3. Immunodetection of NS2-3 and NS3 from BT cells infected with KS86-1ncp, KS86-1cp, 799ncp, 799cp, 839ncp, and 839cp. At 48 h postinfection, the cells were lysed and separated by 10 % SDS-polyacrylamide gel. The separated proteins were transferred to a PVDF membrane and incubated with anti-NS3 MAb 46/1. Numbers on the left indicate the molecular masses (in kilodaltons) according to the marker protein.



Fig.1 Kameyama et al.

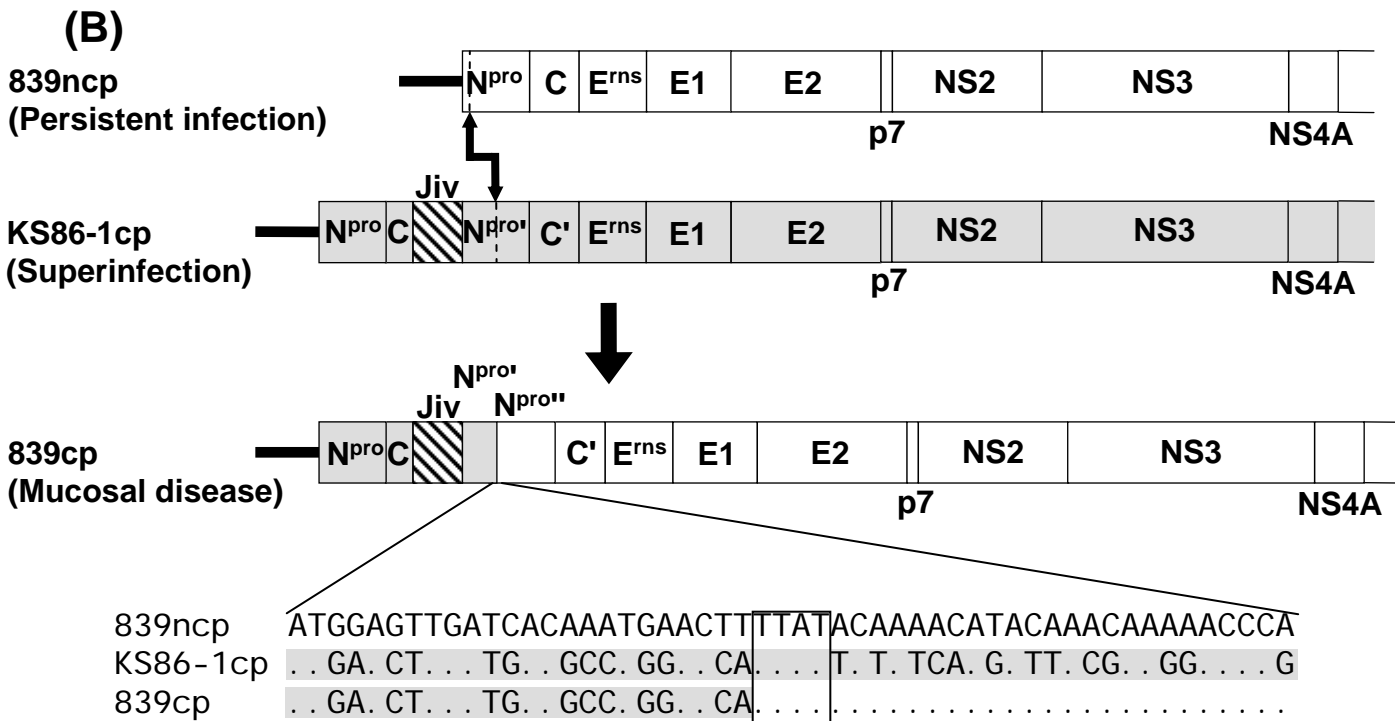
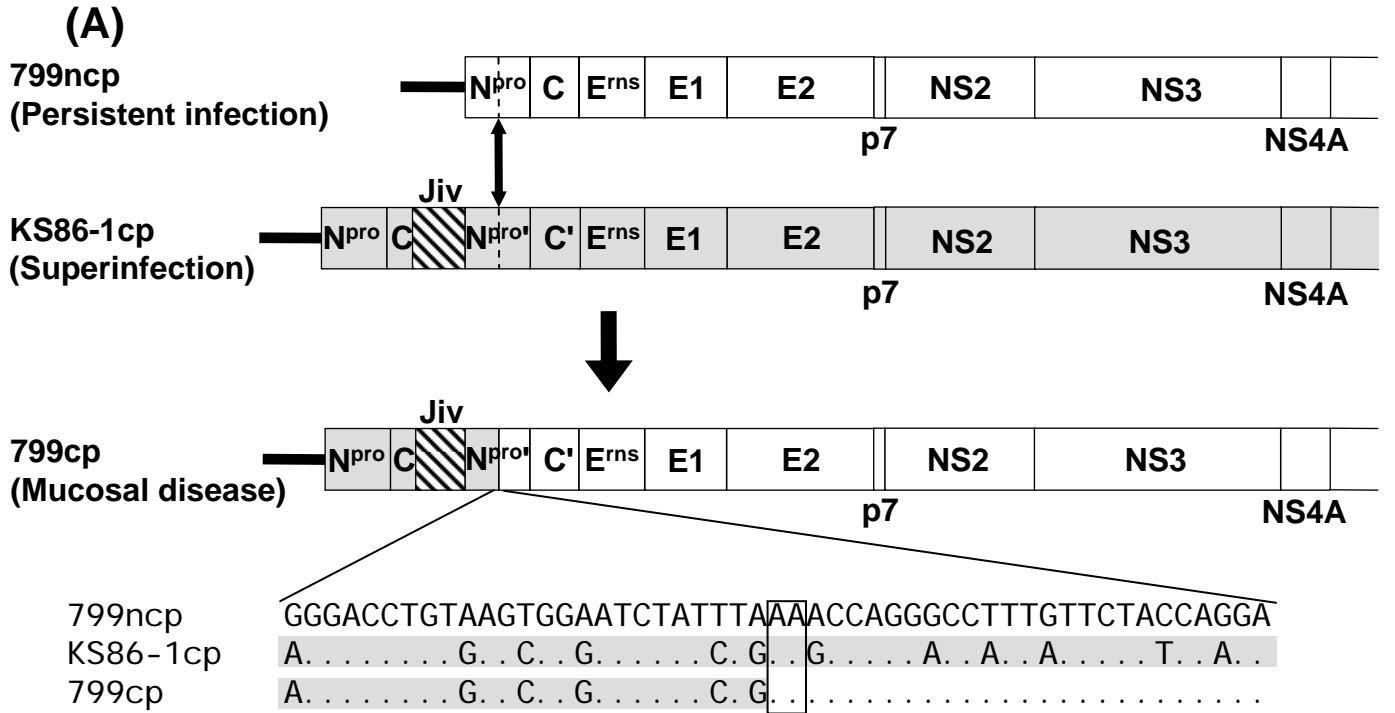

Fig.2 Kameyama et al.

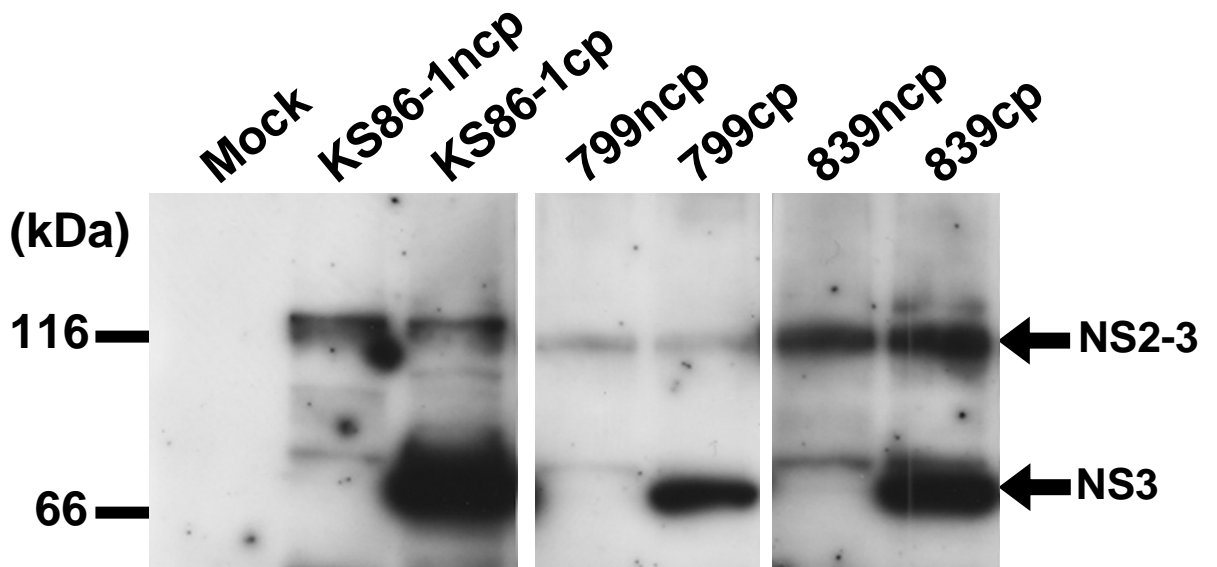

Fig. 3 Kameyama et al.

Table 1. Serological characterization of the isolates by neutralization tests

Viruses	Antisera			
	799ncp	839ncp	KS86-1cp	Nose
799ncp	128	ND	4	16
799cp	128	ND	8	16
839ncp	ND	256	2	32
839cp	ND	512	<2	32
KS86-1ncp	ND	ND	512	8
KS86-1cp	4	2	256	4
Nose	ND	ND	8	256

ND: Not determined

Kameyama et al.