



# HOKKAIDO UNIVERSITY

Title	GaAs Schottky Wrap-Gate Binary-Decision-Diagram Devices for Realization of Novel Single Electron Logic Architecture
Author(s)	Kasai, Seiya; Amemiya, Yoshihito; Hasegawa, Hideki
Relation	International Electron Devices Meeting 2000. Technical Digest. IEDM (Cat.No.00CH37138), 2000, p.585-588
Issue Date	2000
Doc URL	<a href="https://hdl.handle.net/2115/8369">https://hdl.handle.net/2115/8369</a>
Rights	© 2000 IEEE. Personal use of this material is permitted. However, permission to reprint/republish this material for advertising or promotional purposes or for creating new collective works for resale or redistribution to servers or lists, or to reuse any copyrighted component of this work in other works must be obtained from the IEEE. International Electron Devices Meeting 2000. Technical Digest. IEDM (Cat.No.00CH37138), 2000, p.585-588
Type	conference paper
File Information	241.pdf



# GaAs Schottky Wrap-Gate Binary-Decision-Diagram Devices for Realization of Novel Single Electron Logic Architecture

Seiya Kasai<sup>1,2</sup>, Yoshihito Amemiya<sup>2</sup> and Hideki Hasegawa<sup>1,2</sup>

<sup>1</sup>Research Center for Interface Quantum Electronics

<sup>2</sup>Graduate School of Electronics and Information Engineering,  
Hokkaido University, North 13, West 8, Sapporo 060-8628, Japan

## Abstract

Novel single electron binary-decision-diagram (BDD) node devices and circuits based on Schottky wrap-gate (WPG) control of AlGaAs/GaAs nanowires were designed, fabricated and characterized for the first time. The WPG BDD node device showed clear path switching as well as conductance oscillation by WPG voltage control. WPG-based BDD OR logic circuits were also successfully fabricated. It is also shown that more complex-functional BDD circuits can be realized by suitable layouts of WPGs and nanowires.

## Introduction

Because of ultra-small device sizes and ultra-small power-delay products near the quantum limit, single electron devices and their circuits are promising candidates for next generation ultra-high volume information processing. However, low current drive capability, low voltage gain and poor threshold voltage control inherent in single electron transistors (SETs) make exploitation of the conventional Boolean logic architecture difficult.

A promising alternative is the single electron binary-decision-diagram (BDD) logic architecture proposed by Asahi *et al.*[1,2] where device requirements for system realization are much more relaxed. The key issue for hardware implementation is how to realize the BDD node device. A Schottky wrap-gate (WPG) technology developed by Kasai *et al.*[3] is suitable for this application, because of simple lateral structure suited for planar integration, voltage-controllable potential profiles and threshold voltages, and flexibility of device design. Its capability has been demonstrated recently by successful realization of a quantum wire load single electron logic inverter with a transfer gain of 1.3 as well as successful fabrication of a complementary inverter[4].

The purpose of this paper is to propose and fabricate a novel single electron BDD node device based on the Schottky

WPG technology, as well as to demonstrated feasibilities of the WPG BDD technology for circuit applications by fabricating fundamental BDD logic gates and designing more complex circuits.

## Single Electron Binary Decision Diagram

The binary-decision diagram (BDD) is a representation scheme of logic functions by a directed graph consisting of many wired nodes, each labeled by variable,  $x_i$ , and a set of end terminals including terminal-1, terminal-0 and roots. Each node has one entry branch and two exit branches for the information messenger as shown in Fig.1(a) where path of the messenger is switched by variable  $x_i$ . In this study, a single electron is used as the messenger. In order to manipulate single electrons, the novel circuits in the single electron BDD logic architecture consist of a wired array of the BDD node devices each of which has a quantum dot and three tunnel barriers as shown in Fig.1(b) where electrons are manipulated one by one through the single electron tunneling. Namely, the messenger single electron, after coming into the quantum dot through the entry branch, exits either through the 1-branch, or through the 0-branch, depending on the complementary inputs applied to the control gates. An example of the BDD OR circuit is shown in Fig.1(c). The value of the logic

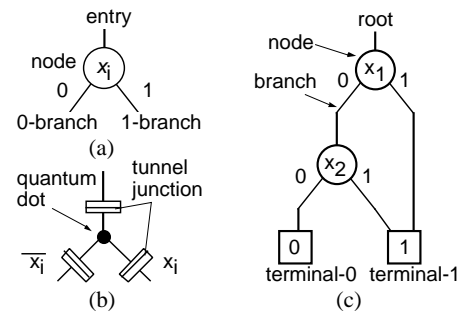

**Fig.1** (a) BDD node device, (b) single electron realization and (c) BDD OR gate.

function is determined by checking whether the messenger from the root can reach to the terminal-1. If the messenger reaches to the terminal-1, then the logic value is true. It is noted that it is possible to omit the terminal-0 from the circuit, and this makes the circuit layout simpler.

### Schottky WPG Structure and BDD Device Design

The Schottky wrap gate (WPG) structure[2] was used to realize a BDD node device. It is schematically shown in Figs.2(a) and (b). Schottky gates are wrapped around an AlGaAs/GaAs etched nanowire with a width of a few hundred nm. The WPG produces a strong confinement potential on the quasi one dimensional electron layer by depleting the heterointerface directly from the top as well as both sides of the structure, resulting in a much tighter control than that of the conventional split gate structures. Control by a single WPG as shown in Fig.2(c) realizes a quantum wire transistor (QWTr). Control by a couple of narrow WPGs can form a SET with double tunneling barriers and a quantum dot in between as shown in Fig.2(d), since a short nanometer-length WPG can form a tunnel barrier by complete depletion of electrons underneath under a negative WPG voltage. By arranging WPGs and nanowires, various more complicate quantum dot structures can be designed and fabricated.

Two possible designs of a single electron BDD node device utilizing the WPG structures are schematically shown in Figs.2(e) and (f) and there were fabricated in this study.

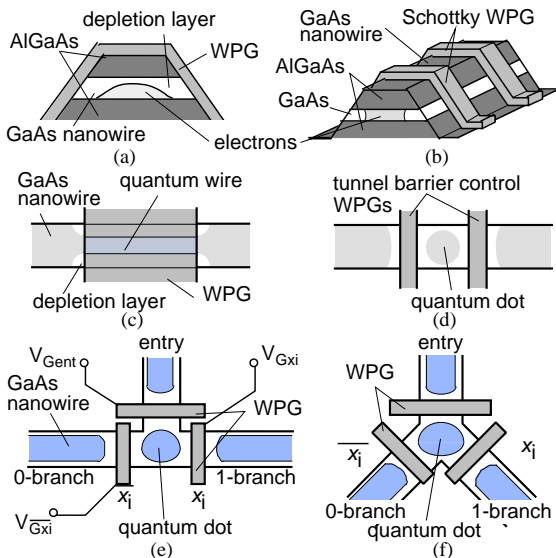

**Fig.2** (a) and (b), Basic structures of Schottky WPG, (c) WPG-based quantum wire, (d) WPG-based SET with a quantum dot, and (e) and (f), two designs of BDD node devices by WPGs.

They have T- and Y-shape arrangement of GaAs nanowires, respectively, and WPGs are attached to the three branches. A quantum dot is formed between the three WPGs. The entry branch WPG is adjusted so that the messenger electron can tunnel into the dot. If the control input  $x_i = "1"$ , then the 1-branch WPG voltage is controlled so as to permit the electron tunneling out to the 1-branch and the 0-branch is kept closed by complete depletion of the nanowire. In the case of  $x_i = "0"$ , control input WPG voltages are exchanged, and the opposite takes place.

### Formation Technology and Basic Properties of WPG-based Quantum Structures

The fabrication process of WPG devices was very simple. After formation of the nanowire pattern by the electron beam (EB) lithography, an AlGaAs/GaAs heterostructure wafer was etched down to form nanowires using the conventional sulfuric acid-based etchant which can realize damage-less smooth side walls. This turned out to be extremely important to form well-behaved Schottky gates. Next, source and drain ohmic contacts were formed by Ge/Au/Ni deposition followed by lift-off and alloying processes. Then, nanometer-length Cr/Au Schottky wrap gates were formed on the GaAs nanowire by the EB-lithography and standard lift-off process. Thus, no special technique is required for planar integration of the WPG-devices and circuits fabrication.

Before fabricating BDD devices, properties of basic WPG quantum structures were investigated by fabricating

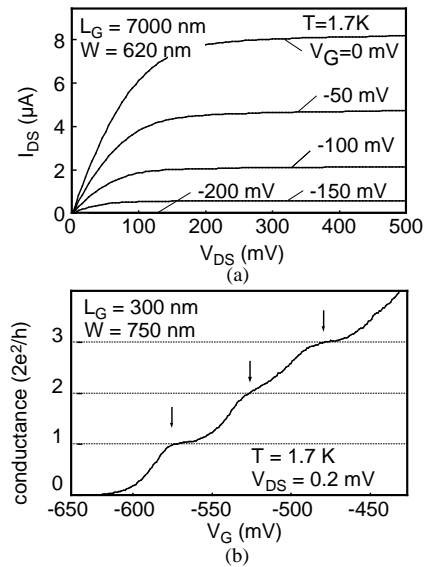
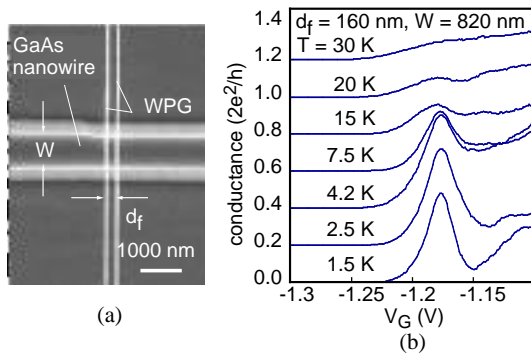

**Fig.3** (a)  $I_{DS}$ - $V_{DS}$  and (b) quantized conductance of WPG QWTr.

WPG QWTrs and SETs. Figure 3 (a) shows the  $I_{DS}-V_{DS}$  characteristics of a WPG QWTr shown in Fig.1(c). It had good gate-controllability and showed complete channel pinch-off. With a submicron WPG, the device showed clear conductance quantization near pinch-off as shown in Fig.3(b). These results show that the WPG can produce the voltage-controllable strong lateral confinement potential. Figure 4 (a) shows an SEM image of the 2-gate WPG SET having a couple of tunnel-barrier control gate. The WPG length was typically 50 nm and the nanowire widths were 400-800 nm. As shown in Fig.4(b), the WPG SET showed large conductance peaks and the number of the conductance peaks was small. The oscillations were visible up to 20-30 K. These characteristics can be explained by a single electron lateral resonant tunneling[5]. It should be noted that presence of a single high peak is sufficient for a BDD application. The typical electron addition energy in the WPG SET was estimated about 8 meV, which was much larger than that of the split gate SET. By repeating these basic structure and adjusting WPG biases, quantum dot arrays can be formed easily as shown in Figs.5.

### WPG-based BDD node device

Using the WPG technology, single electron BDD node devices was successfully designed and fabricated. The SEM micrograph of the fabricated WPG-based BDD node device based on the design in Fig.2(e) is shown in Fig.6. Three 50



**Fig.4** (a) Fabricated 2-gate WPGSET and (b) its conductance oscillation characteristics.

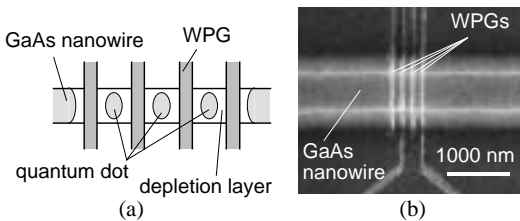
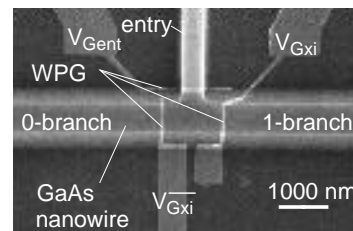

**Fig.5** (a) Schematic view and (b) SEM image of WPG quantum dot array.

nm-long WPGs were formed on a T-shaped GaAs nanowire and they produced three tunneling barriers and a quantum dot in between.

In the WPG BDD node device, each of the two entry-to-exit branch paths could be operated as a SET. The conductance oscillation of the fabricated WPG BDD node device is shown in Fig.7(a). In this measurement, only the 1-branch WPG voltage was swept keeping the other WPG voltages constant, and the 0-branch circuit was opened. The device showed a small number of clear conductance oscillation peaks even though the device size was 1000 nm. From the Coulomb diamond chart, the charging energy was estimated to be 2.3 meV.

The BDD operation was realized by complementary input-voltage application to the exit-branch WPGs,  $V_{Gxi}$  and



**Fig.6** SEM image of WPG-controlled single electron BDD node device.

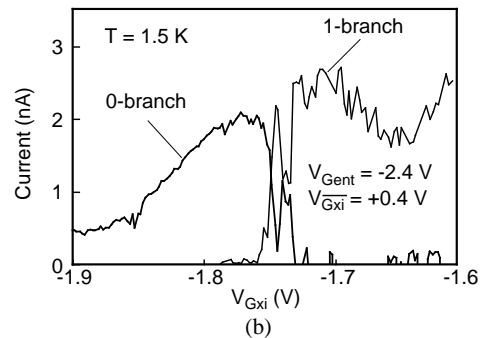
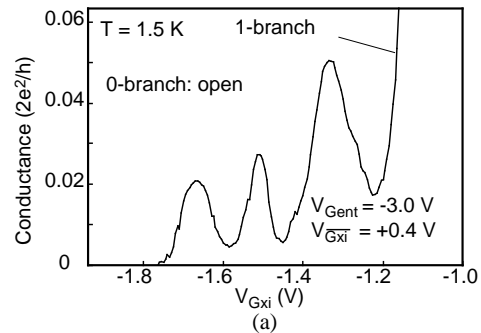

**Fig.7** (a) Conductance oscillation and (b) switching characteristics of the BDD device.

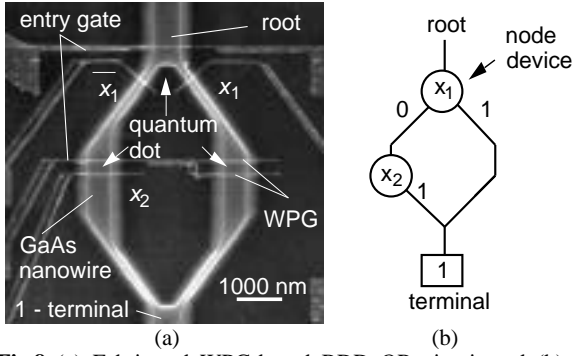

**Fig.8** (a) Fabricated WPG-based BDD OR circuit and (b) its equivalent circuit diagram.

$V_{Gxi}$ . Fig.7(b) shows the path switching characteristics of the WPG BDD node device. Only the 1-branch WPG voltage was swept and the other WPG voltages were kept constant. Importantly, the device could realize a clear path switching operation with a sharp transition near the switching threshold. The basic oscillation feature seen in Fig.7(a) was retained in Fig.7(b), indicating that Coulomb oscillation in the resonant tunneling regime is responsible for this BDD device operation.

### Design and Fabrication of BDD Logic Circuits

Various BDD circuits realizing fundamental and complex functions can be designed and fabricated by suitable arrangements of WPGs on GaAs nanowire patterns. To confirm such feasibility, a basic BDD OR circuit was fabricated exactly the same process as that of the discrete WPG devices. An SEM image of the circuit and its equivalent circuit diagram are shown in Fig.8(a) and (b), respectively. The circuit has a BDD node device with a Y-shape nanowire. The hexagonal nanowire arrangement was formed by using the EB lithography and wet chemical etching. The BDD OR circuit has a root, a terminal-1 and three quantum dots with the six of entry- and input-WPGs. The 0-branch of the node  $x_2$  and the terminal-0 were omitted from this circuit for simplicity as described before. By setting suitable WPG voltages, a proper OR logic operation of the circuit was obtained.

Figure 9(a) and (b) show a BDD circuit diagram for a 2-bit adder and its WPG implementation, respectively. As shown in this example, complex functional circuits can be realized by the combination of BDD node devices only. The operation of the BDD circuit was investigated by computer simulation[6] and the circuit was found to give the expected correct outputs.

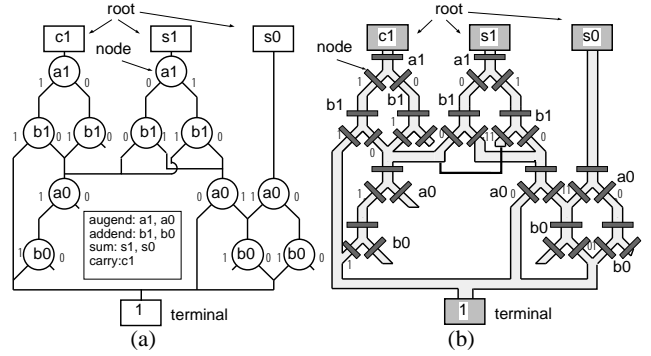

**Fig.9** BDD 2-bit adder (a) equivalent circuit diagram and (b) its representation by WPG.

### Conclusion

Novel single electron binary-decision-diagram (BDD) node devices based on Schottky wrap-gate (WPG) control of GaAs nanowires were demonstrated. The device showed clear BDD path switching characteristics. Basic WPG-based single electron BDD logic circuits were also fabricated and the feasibility for complex logic functions was confirmed.

### References

- (1) N. Asahi, M. Akazawa, and Y. Amemiya, *IEEE Trans. Electron Devices*, vol. 42, pp.1999-2003, 1995.
- (2) N. Asahi, M. Akazawa, and Y. Amemiya, "Single-Electron Logic Device Based on the Binary Decision Diagram" *IEEE Trans. Electron Devices*, vol. 44, pp.1109-1116.
- (3) S. Kasai, K. Jinushi, H. Tomozawa, and H. Hasegawa, "Fabrication and Characterization of GaAs Single Electron Devices Having Single and Multiple Dots Based on Schottky In-Plane-Gate and Wrap-Gate Control of Two-Dimensional Electron Gas", *Jpn. J. Appl. Phys.*, vol. 36, pp.1678-1685, 1997.
- (4) S. Kasai, and H. Hasegawa "GaAs Single Electron Transistors and Logic Inverters Based on Schottky Wrap Gate Structures", presented at *58th DRC*, Denver, June 19-21, 2000, Conf. Dig., pp.155-156.
- (5) S. Kasai, Y. Satoh and H. Hasegawa, "Conductance oscillation characteristics of GaAs Schottky wrap-gate single-electron transistors", *Physica B*, vol. 272, pp.88-91, 1999.
- (6) Y. Kinoshita, T. Yamada, S. Kasai, Y. Amemiya and H. Hasegawa, "Quantum-Dot Logic Systems Based on the Shared Binary-Decision Diagram", presented at *2000 Int. Symp. on Formation, Physics and Device Application of Quantum Dot Structures*, Sep.10-14, 2000, Sapporo, Japan., Collected Abstracts p. 124.