



Title	A multiobjective proposal for the TEAM benchmark problem 22
Author(s)	Guimarães, Frederico G.; Campelo, Felipe; Saldanha, Rodney R. et al.
Citation	IEEE transactions on magnetics, 42(4), 1471-1474 <a href="https://doi.org/10.1109/TMAG.2006.871570">https://doi.org/10.1109/TMAG.2006.871570</a>
Issue Date	2006-04
Doc URL	<a href="https://hdl.handle.net/2115/8520">https://hdl.handle.net/2115/8520</a>
Rights	(c) 2006 IEEE. Personal use of this material is permitted. However, permission to reprint/republish this material for advertising or promotional purposes or for creating new collective works for resale or redistribution to servers or lists, or to reuse any copyrighted component of this work in other works must be obtained from the IEEE
Type	journal article
File Information	01608495.pdf



# A Multiobjective Proposal for the TEAM Benchmark Problem 22

Frederico G. Guimarães<sup>1</sup>, Felipe Campelo<sup>3</sup>, Rodney R. Saldanha<sup>1</sup>, Hajime Igarashi<sup>3</sup>, Ricardo H. C. Takahashi<sup>2</sup>, and Jaime A. Ramírez<sup>1</sup>

<sup>1</sup>Department of Electrical Engineering, Federal University of Minas Gerais, Belo Horizonte, MG 31270-010, Brazil

<sup>2</sup>Department of Mathematics, Federal University of Minas Gerais, Belo Horizonte, MG 30123-970, Brazil

<sup>3</sup>Graduate School of Information Science and Technology, Hokkaido University, Sapporo 060-0814, Hokkaido, Japan

The TEAM benchmark problem 22 is an important optimization problem in electromagnetic design, which can be formulated as a constrained mono-objective problem or a multiobjective one with two objectives. In this paper, we propose a multiobjective version with three objectives, whose third objective is related to the quench constraint and the better use of the superconducting material. The formulation proposed yields results that provide new alternatives to the designer. We solved the formulation proposed using the multiobjective clonal selection algorithm. After that, we selected a particular solution using a simple decision making procedure.

**Index Terms**—Electromagnetic design, multiobjective optimization, TEAM benchmark problem 22.

## I. INTRODUCTION

THE TEAM benchmark problem 22 deals with the optimization of a superconducting magnetic energy storage (SMES) configuration [1] (see Fig. 1). The objectives are to maintain a prescribed level for the stored energy on the device and to minimize the strayed field evaluated along lines *a* and *b* in Fig. 1, while not violating the quench condition that assures the superconductivity state. A multiobjective version of this problem has already been solved in [2], where the authors approach the same problem with two objectives: 1) to minimize the stray field and 2) to minimize the deviation from the prescribed value for the stored energy (180MJ).

In fact, given some considerations, almost all mono-objective optimization problems may be formulated as multiobjective ones. In the same way, multiobjective problems can be treated as mono-objective ones, for example, by adopting the weighted sum of the objectives, although this approach limits the search for more promising alternatives. Even constraints may be treated as new objectives [3].

Multiobjective formulations are more flexible to the designer, which can specify various criteria simultaneously. On the other hand, the price to be paid for this flexibility in multiobjective design is a more complex optimization process. Moreover, an additional decision process must be performed in order to select which solution will be chosen and eventually built.

We propose, in this paper, a novel multiobjective version for problem 22. In addition to the two objectives, a third objective is defined regarding the quench condition and the better use of the superconducting material.

## II. PROPOSED FORMULATION

The quench condition in the problem 22 is given by the linearization of the experimental curve of the material (see Fig. 2).

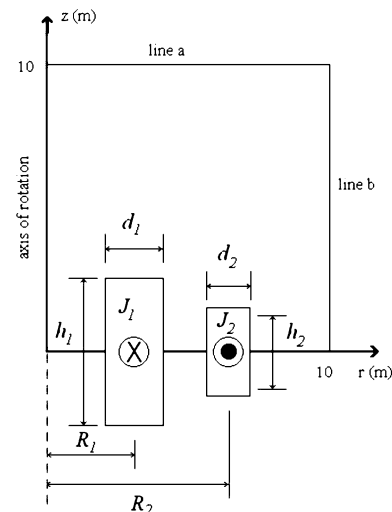

Fig. 1. Two-dimensional axisymmetric configuration of the SMES device.

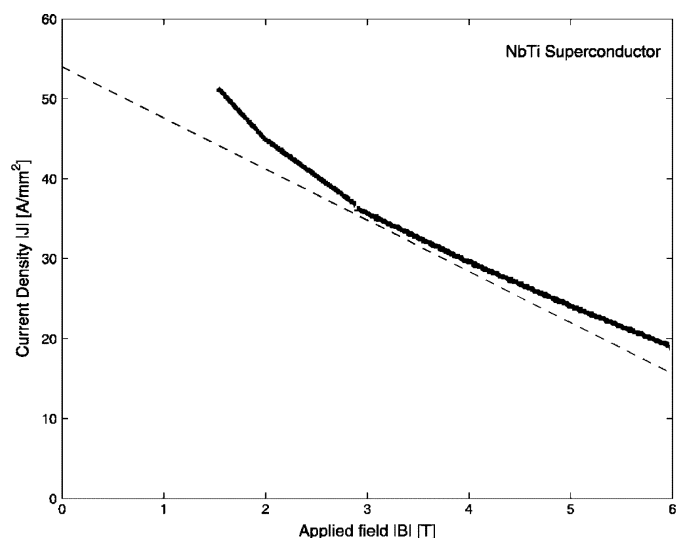

Fig. 2. Critical curve of the material.

In the three parameters version, the current density is equal to 22.5 A/mm<sup>2</sup>, which gives

$$B_{\max} \leq 4.92T \quad (1)$$

as the inequality constraint for the quench condition.

However, a solution that is quite below the limit is, in fact, subutilizing the superconducting material, since the current density could be greater. At the same time, a solution too close to the critical limit would be dangerous, since any small variation in the current density could cause the device to break the superconductivity state. The linearization curve is already slightly below the real curve, but the designer may still specify a safe limit level

$$|B_{\max,i}| \leq \frac{54.0 - |J_i|}{6.4} - \xi_i, \quad i = 1, 2 \quad (2)$$

where  $B_{\max,i}$  is the maximum magnetic flux density in  $T$  at coil  $i$ ,  $J_i$  is the current density in A/mm<sup>2</sup> for the coil  $i$ , and  $\xi_i \geq 0$  are a safe slack defined by the designer.

Given this consideration, the new multiobjective formulation for the problem 22 may be stated as the minimization of the following objectives:

$$f_1 = B_{\text{stray}} = \sqrt{\frac{\sum_{i=1}^{21} |B_{\text{stray},i}|^2}{21}} \quad (3)$$

$$f_2 = \left| \frac{\text{Energy} - E_0}{E_0} \right| \quad (4)$$

$$f_3 = \sum_{i=1,2} \{|J_i| + 6.4(|B_{\max,i}| + \xi_i) - 54.0\}^2 \quad (5)$$

subject to

$$|J_i| + 6.4(|B_{\max,i}| + \xi_i) - 54.0 \leq 0 \quad (6)$$

where  $B_{\text{stray},i}$  is the magnetic flux density evaluated in each of the 21 evaluation points for the strayed field along lines  $a$  and  $b$  (see Fig. 1). *Energy* is the stored energy for the current configuration, and  $E_0 = 180MJ$ . The objective  $f_2$  gives the percentual deviation from the prescribed value of stored energy [2]. The finite-element model is used for evaluating the stored energy, while the field values are calculated using the Biot–Savart law directly. For the eight -parameter version, we have the additional geometric constraint

$$R_1 + h_1/2 - R_2 + h_2/2 \leq 0 \quad (7)$$

that is, the superposition of the coils is not permitted.

Observe that the constraint for the quench condition is preserved, but the third objective aims at obtaining a solution near to the limit of the quench condition, considering the prescribed level  $\xi_i$ . In fact, different operating points are available in the Pareto solutions achieved, from which the most adequate design may be selected.

### III. METHODOLOGY FOR SOLVING THE MULTI-OBJECTIVE PROBLEM

The objectives (3)–(5) were optimized using the multiobjective clonal selection algorithm (MOCSA) [4]. This algorithm is inspired by principles of the immunology and adapted to multiobjective problems. This section reviews briefly this algorithm.

The MOCSA can be considered an extension of immune-based algorithms [5], [6] to multiobjective problems. MOCSA is inspired by the clonal selection theory, which states that those cells from the adaptive immune system that have greater affinity measure to a specific antigen will produce more clone cells. The basic steps used for the definition of the MOCSA operation are 1) affinity evaluation, 2) cloning, 3) maturation, and, finally, 4) replacement. The algorithm starts with the generation of an initial population containing  $N_p$  cells. Each cell represents a randomly generated point in the previously specified search space. The basic steps are described next.

#### A. Affinity Evaluation

Each individual is evaluated for all objectives of the problem, penalizing any violation of the constraints. After that, the solutions are sorted according to the nondominated frontier to which they belong [4]. This nondominated sorting scheme is similar to the approach already employed in some multiobjective genetic algorithms.

#### B. Cloning

The next step is to generate the same number of clones for all solutions belonging to the same front, considering that the entire population has been classified in nondominated fronts. This is done according to the equation

$$N_{C,i} = \text{round} \left( \frac{\beta N_p}{i} \right). \quad (8)$$

For example, all solutions in the first nondominated front ( $i = 1$ ) receive  $\text{round}(\beta N_p)$  clones, those in the second front ( $i = 2$ ) receive  $\text{round}(\beta N_p/2)$ , and so forth. The clones are exact copies of the original solution.

#### C. Maturation

The maturation process consists of the addition of a Gaussian perturbation to the original solutions, in order to generate small variations around the original point. This process has the characteristic of performing local refinements in the solutions. Given that the best solutions receive more clones, the local search is more intense for the most promising regions.

#### D. Replacement

The entire population, consisting of the original solutions and their matured clones, is classified again into nondominated fronts. The first front is stored in an external memory population. Through the iterative cycles, every new update of the memory population employs a niching technique to avoid the storage of very similar solutions. The niching is applied to both the space of parameters and the space of objectives, as suggested in [7].

A percent of the best individuals, i.e., the less dominated ones, is selected for the next iteration. Hence,  $cN_p$  solutions (with  $c \in [0, 1]$ ) are directly selected for the next iteration. The remaining solutions are eliminated and new randomly generated ones are introduced for completing the population, thus maintaining a constant population size  $N_p$ .

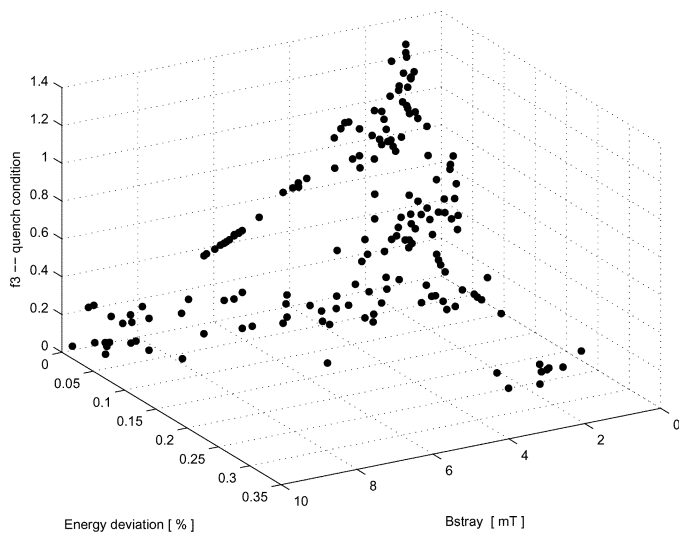

Fig. 3. Pareto solutions found by MOCSA in the space of objectives.

### E. Summary of the Algorithm

The previous steps are summarized in the following algorithm.

#### The MOCSA algorithm

- Step 1. Initialize the population of antibodies.
- Step 2. **While** (Stop criterion is not met) **do**:
  - 2.1- Evaluate antibodies;
  - 2.2- Perform nondominated sorting;
  - 2.3- Cloning and maturation;
  - 2.4- Evaluation of the matured clones;
  - 2.5- Perform nondominated sorting again over all solutions (original solutions and their clones);
  - 2.6- Selection and storing;
  - 2.7- Suppression over the external memory population using niching scheme;
  - 2.8- Replacement and diversity generation.

## IV. RESULTS

### A. Three-Parameter Version

First, we present results for the three-parameter version and for  $\xi = 0$ . In the three parameters version, MOCSA determined 171 estimatives of the Pareto set with a total of 2 932 function calls. The estimated three-dimensional (3-D) Pareto front is shown in Fig. 3. The 3-D space of objectives consists of the estimated value for the strayed field  $B_{\text{stray}}$ , the percentual deviation from the prescribed value for energy, and the proximity to the quench limit. Fig. 4 illustrates the obtained solutions in the space of parameters. Table I shows the optimal solutions for each objective determined from the Pareto estimatives.

After a set of Pareto solutions is found, the designer must decide which solution will be selected. The decision-making stage is very particular for each problem and many sophisticated decision-making techniques are available in the literature [8]. Nevertheless, we use the following criteria for the decision-making stage.

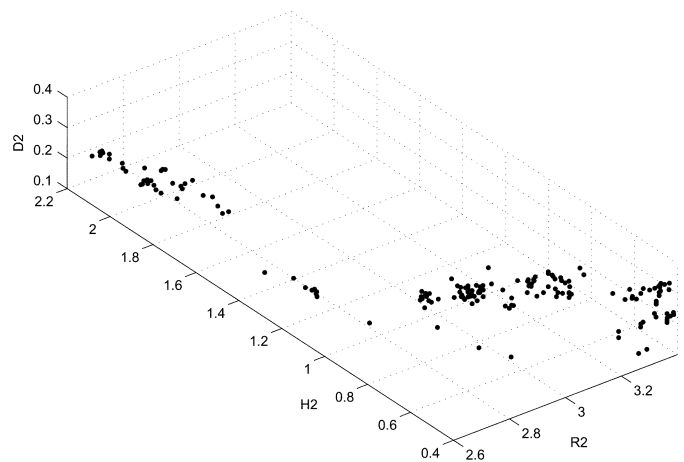

Fig. 4. Pareto solutions in the space of parameters.

 TABLE I  
INDIVIDUAL OPTIMA

	$R_2$	$h_2$	$d_2$	$B_s$	$E$	$B_{\text{max}}$
Unit	$m$	$m$	$m$	$mT$	$MJ$	$T$
$f_1$	2.6602	1.1148	0.2218	0.50	134.38	4.56
$f_2$	3.0671	0.6660	0.2986	1.14	179.97	4.37
$f_3$	2.9801	0.6660	0.3378	1.95	180.48	4.89

- 1) We eliminate the solutions that have  $B_{\text{stray}} > 3$  mT and  $f_2 > 10\%$ , which means an energy outside the range  $E_0 \pm 18MJ$ .
- 2) After that, we select from the remaining solutions the one that corresponds to the smallest volume of material:  $V = 2\pi R_2 h_2 d_2$ .

Using these criteria, we get the final selected solution

$$[R_2 \ h_2 \ d_2] = [3.4000 \ 0.4397 \ 0.2945] \quad (9)$$

at which  $B_{\text{stray}} = 2.56$  mT, Energy = 184.53 MJ, and  $B_{\text{max}} = 4.07$  T. The volume of material is 2.7665 m<sup>3</sup>.

For comparison, the best solution from [1] is

$$[R_2 \ h_2 \ d_2] = [3.0800 \ 0.4780 \ 0.3940] \quad (10)$$

at which  $B_{\text{stray}} = 0.89$  mT, Energy = 179.80 MJ,  $B_{\text{max}} = 3.63$  T, and the volume of material is 3.6446 m<sup>3</sup>.

### B. Eight-Parameter Version

Now, we analyze the full version of the problem, in which the dimensions of both coils and the applied current densities are optimized. The MOCSA was applied again in order to find estimatives of the Pareto set, but a different approach is employed. With the aim of reducing the computational cost of the overall optimization process, we utilize the following strategy.

- Initialize a counter for the function calls, e.g.,  $\text{calls} \leftarrow 0$ .
- The MOCSA runs over the electromagnetic solver until  $\text{calls}$  is equal to 2 000 and all function evaluations are stored.
- After that, the electromagnetic solver is turned off and a radial basis function approximation is generated with the data stored.
- All subsequent evaluations are performed by the approximated model.

The data gathered during the initial phase have very interesting characteristics. Since MOCSA presents a diversity generation mechanism (random generation of new solutions), the search space is uniformly sampled. On the other hand, due to the maturation process, the most promising regions identified present a higher density of samples, allowing the generation of a more refined approximation.

The initial phase of the optimization process is used to sample the search space in a more intelligent way. After that, the approximation provides the evaluation of the points. The radial basis approximation is given by

$$m(x) = \sum_{i=1}^N \alpha_i \phi_i(c_i, x) \quad (11)$$

where  $x$  is the input point, and  $m(x)$  its evaluated output. The model is given by the linear combination of  $N$  nonlinear radial basis functions  $\phi_i(\cdot)$ , centered at  $c_i$ . Here, we employ the multiquadric function as the radial basis function

$$\phi_i(c_i, x) = \sqrt{\|x - c_i\| + s^2}. \quad (12)$$

The employment of this approach, particularly multiquadric-based approximations, is a very successful approach in electromagnetic design [9].

In order to alleviate the complexity of the model generation, we utilize locally approximated models generated with samples from the data that are closer to the point we need to evaluate.

Using this methodology, MOCSA found 246 estimatives of the Pareto set, and consumed a total of 20 306 function calls, from which only the first 2000 involved calls to the electromagnetic solver.

Similarly to the three-parameter version, we adopt the following criteria for decision-making.

- 1) We eliminate the solutions that have  $B_{\text{stray}} > 3$  mT and  $f_2 > 15\%$ , which means an energy outside the range  $E_0 \pm 27$  MJ.
- 2) After that, we select from the remaining solutions the one that corresponds to the smallest volume of material:  $V = 2\pi(R_1 h_1 d_1 + R_2 h_2 d_2)$ .

The solution obtained is shown in Table II and compared to the solution from [1].

The multiobjective approach adopted here has the benefit of finding many alternative designs for the problem, including many different operating points for the superconducting material. Having all the alternatives in hand, the designer may proceed to a final stage of selection and analysis of the solutions in order to determine which is the most adequate.

## V. CONCLUSION

A novel multiobjective proposal for the SMES design in the problem 22 has been presented which aims at obtaining solutions that are near the limit of the quench condition, but still considering a safety level established by the designer. In fact, the

TABLE II  
FINAL SOLUTION OBTAINED AFTER DECISION MAKING

Param	Unit	value	best [1]
$R_1$	$m$	2.6822	1.5703
$h_1$	$m$	1.0816	1.5692
$d_1$	$m$	0.2652	0.5943
$R_2$	$m$	4.0355	2.0999
$h_2$	$m$	0.4753	2.8368
$d_2$	$m$	0.2470	0.2562
$J_1$	$A/mm^2$	26.5118	17.3367
$J_2$	$A/mm^2$	26.5262	12.5738
$f_1$	$mT$	2.6714	0.0148
$f_2$	-	0.1272	0.0033
$f_3$	-	0.3300	1.7951
$V$	$m^3$	7.8101	18.7905

third objective represents a criterion to select amongst solutions that satisfy the quench condition at different operating points. This introduces a new perspective to a well-known and quite explored benchmark problem in electromagnetic optimization.

Finally, the three-objective version is a more complex multi-objective problem. We expect it may be useful for testing multi-objective algorithms in electromagnetic design.

## ACKNOWLEDGMENT

This work was supported in part by the National Council of Scientific and Technologic Development—CNPq—under Grants 300 353/1997-9 and 141 731/2004-4 and in part by Fapemig under Grant TEC-941/05, Brazil.

## REFERENCES

- [1] TEAM Workshop Problem 22: SMES Optimization Benchmark [Online]. Available: <http://www-igte.tu-graz.ac.at/archive/team/index.htm>
- [2] A. H. F. Dias and J. A. Vasconcelos, "Multiobjective genetic algorithms applied to solve optimization problems," *IEEE Trans. Magn.*, vol. 38, no. 2, pp. 1133–1136, Mar. 2002.
- [3] D. A. G. Vieira, R. L. S. Adriano, J. A. Vasconcelos, and L. Krähenbühl, "Treating constraints as objectives in multiobjective optimization problems using niched pareto genetic algorithm," *IEEE Trans. Magn.*, vol. 40, no. 2, pp. 1188–1191, Mar. 2004.
- [4] F. Campelo *et al.*, "A novel multiobjective immune algorithm using non-dominated sorting," presented at the 11th Int. IGTE Symp. Numerical Field Calculation in Electrical Engineering, Sep. 13–15, 2004.
- [5] L. N. de Castro and F. J. Von Zuben, "Learning and optimization using the clonal selection principle," *IEEE Trans. Evol. Comput.*, vol. 6, no. 3, pp. 239–251, Jun. 2002.
- [6] F. Campelo, F. G. Guimarães, H. Igarashi, and J. A. Ramírez, "A clonal selection algorithm for optimization in electromagnetics," *IEEE Trans. Magn.*, vol. 41, no. 5, pp. 1736–1739, May 2005.
- [7] S. L. Ávila, W. P. Carpes Jr., L. Krähenbühl, and J. A. Vasconcelos, "The niche technique in parameters and fitness space for multiobjective genetic algorithm optimization," presented at the 11th International IGTE Symp. Numerical Field Calculation in Electrical Engineering, Sep. 13–15, 2004.
- [8] C. A. C. Coello, "Handling preferences in evolutionary multiobjective optimization: A survey," in *Proc. IEEE Congr. Evolutionary Computation*, vol. 1, 2000, pp. 30–37.
- [9] A. Canova, G. Grusso, and M. Repetto, "Magnetic design optimization and objective function approximation," *IEEE Trans. Magn.*, vol. 39, no. 5, pp. 2154–2162, Sep. 2003.