



HOKKAIDO UNIVERSITY

Title	On the Electrification of Dew by Water Droplets
Author(s)	MAGONO, Choji; TAKAHASHI, Tsutomu
Citation	Journal of the Faculty of Science, Hokkaido University. Series 7, Geophysics, 1(2), 69-79
Issue Date	1958-11-05
Doc URL	https://hdl.handle.net/2115/8621
Type	departmental bulletin paper
File Information	1(2)_p69-79.pdf



On the Electrification of Dew by Water Droplets

Choji MAGONO and Tsutomu TAKAHASHI

(Received June 1, 1958)

Abstract

It was observed that frost produced artificially on a thin wire was electrified, but no steady regularity in the polarity was found in the electrification phenomena. Later, by more careful experiments it was noted that dew produced by almost the same method as the frost making method was electrified negatively when the water temperature of the reservoir for the supply of water vapor was lower than about 80°C and positively when the temperature was higher than about 85°C. The electrification phenomena of the dew or the frost were considered to have originated from the electric charge on individual water droplets, because it was observed that the droplets were electrified at the time when they rose from the water surface of the reservoir, and the sign of charge on the individual droplets agreed well with that of the dew.

1. Introduction

It is considered that the freezing phenomenon of supercooled cloud particles forming graupel or hail is closely related with the charge generation of thunderclouds,^{1), 2), 3), 4), 5)} although the physical mechanism is not yet understood in detail.

When the authors attempted experiments to measure the charge on the rimed frost which formed on a thin wire, they found that the frost was electrified, sometimes negatively, at other times positively; however they could not find any steady regularity in the sign of the charge. During the experiments, they noted that the wire was also charged like the frost as stated in Table 1, even if it was not cooled below freezing temperature: in other words, the

Table 1 Charge on Frost and Dew.

Signs of charge	Times detected	
+	2	Frost
-	1	
not detected	16	
+	4	Dew
-	16	
-+	3	
not detected	12	

dew on the wire was observed apparently to be electrified by the water vapor. The times of negative charge detected seemed to be larger than times of positive one, however, the result of the experiments could not be repeated.

Further careful experiments revealed that the sign of charge on the dew depended on the temperature of the reservoir for supplying the water vapor to the wire. It was also noted that the electric current for heating the water in the reservoir was another factor. That is to say, both the magnitude and the sign of the charge were considered to be due to the behavior of steam particles arising from the water surface. The authors observed the charge of individual steam particles rising from the reservoir.

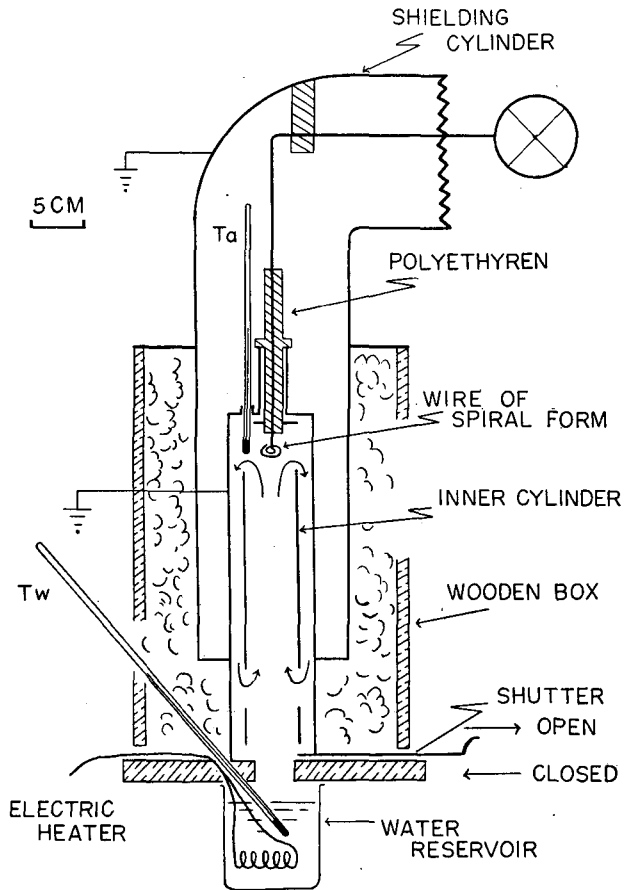

Fig. 1.

It is considered that the possible electrification of water droplets before impact with any other body should be investigated, in such laboratory experiments or observations for electrification phenomenon of riming process, as pointed out by Chalmers.⁶⁾

2. Apparatus

The apparatus used is similar to that used by Nakaya⁷⁾ to make artificial snow except for the insulating parts for measuring the charge on dew, as shown in Fig. 1. Water vapor is supplied through the inner cylinder from the water reservoir which is heated electrically. The temperature of the water is measured by thermometer T_w . Dew is deposited on a thin copper wire of spiral form which is situated above the top of the inner cylinder. The temperature of the air near the wire is measured by thermometer T_a . The outside of the upper end of the inner cylinder may be covered with dry ice if frost is needed. The wire is connected electrically to a quadrant

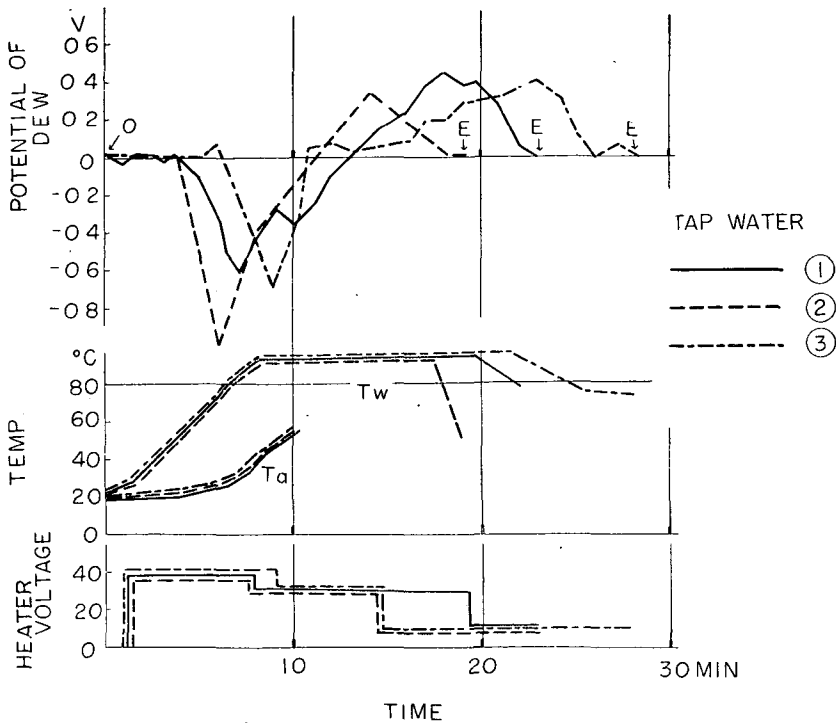

Fig. 2.

electrometer. Polyethyren rods served sufficiently as electric insulators during the experiments. A shutter under the lower end of the inner cylinder is kept closed until vapor supply is needed. The air in the apparatus circulates as shown by arrows in the figure. Tap water was used to supply vapor for dew or frost, as a rule.

3. Charge on dew

The temperature of water; T_w and the electric current of the heater in the water reservoir were measured simultaneously with the electric potential of dew, since it is considered that the most important factors were the water temperature and the electric current.

Three abscissae in Fig. 2 represent time in minutes from the beginning of the measurement of charge. Three curves (solid, dotted and chain lines) show the potential changes under three similar conditions in Exps. No. 1, 2 and 3. In the figure, O and E show in each case the instant when the shutter

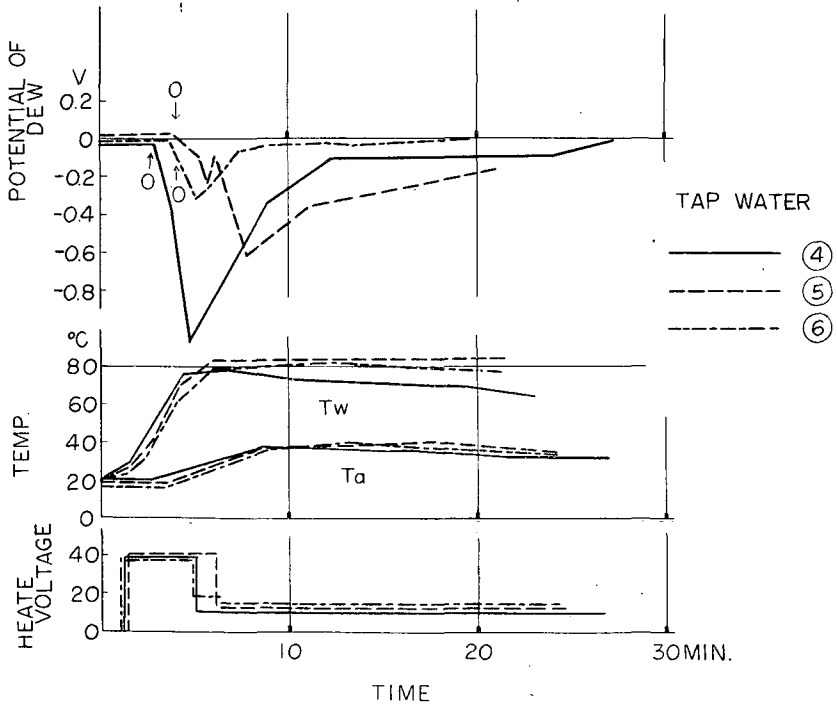

Fig. 3.

is opened and the time when the wire system is connected to the earth respectively. The curves in the middle figure represent the temperature changes of water: T_w and of air: T_a . The curves in the lower figure show the voltages of the transformer controlling the heater current.

One may see that several minutes after the shutter opening, the potential of the dew dropped to about minus 0.6 volts, however, as T_w became higher, it ascended to plus 0.4 volts passing through zero volt line. The time when the potential curve reached its minimum as shown in the upper figure corresponds roughly to the time when the heater voltage dropped from 40 to 30 volts; the maximum of the curve corresponds to the second drop of heater voltage from 30 to 10 volts.

However, the descent of potential after the maximum is supposed, to a certain extent, to have resulted from some leakage in the electrical insulation system.

In order to ascertain the first negative change of the potential in detail,

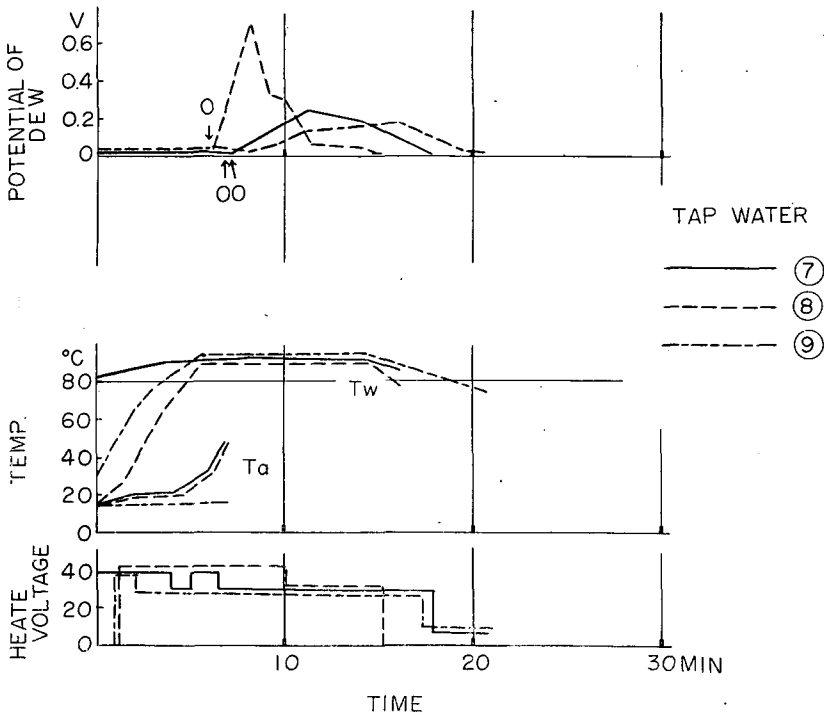

Fig. 4.

T_w was limited to a range lower than 80°C as shown in Exps. No. 4, 5 and 6 graphed in Fig. 3. In this case one sees that the potential descended to negative as in Exps. No. 1, 2 and 3, but it did not change to positive after that minimum. On the other hand, when the shutter was kept closed until T_w reached about 85°C , the potential did not descend to negative but ascended to positive from the beginning of supply of vapor as shown in Fig. 4. Considering these facts, it is concluded that in the apparatus the dew is electrified negatively when T_w is lower than 80°C and positively when T_w is higher than 85°C .

4. Charge on individual droplets

During the experiments, a possibility was noted that water droplets were charged originally at the instant when they rose from the water surface of the reservoir, because numerous small bubbles were observed to be produced from the heater wire when electric current (A.C.) was supplied to the wire. Some parts of the apparatus, therefore, were improved in order to enable measurement of the charge on individual droplets. Alterations are shown in Fig. 5.

The spiral wire system for measuring the charge on the dew was removed, and two parallel electrode plates were introduced into the inner cylinder. Both electric potential 2000 volts A.C. and 800 volts D.C. were supplied to the electrodes to determine the magnitude and sign of the charge on droplets. The distance between the two electrodes was 17mm. The rectangular region enclosed by dotted lines in the figure corresponds to the field of view. If a droplet is electrified, it leaves a track of sine curve type caused by its mobility under the influence of the horizontal A.C. field, and is deflected to the right or left side according to the sign of its charge by the D.C. field. The track of droplets is shown by the photographs in Pl. I. The direction of the D.C. field is represented in the left side of the photograph; T_w is stated at the bottom of each picture. The white area seen in each picture represents the bundle of tracks of numerous droplets without charge.

In the photograph, one may discern the bases for the following conclusions:

- i) most of droplets are not electrified, but some droplets are electrified all the time,
- ii) almost all droplets with charge have negative charge when T_w is about 50°C ,
- iii) as T_w becomes higher, the number of droplets with positive

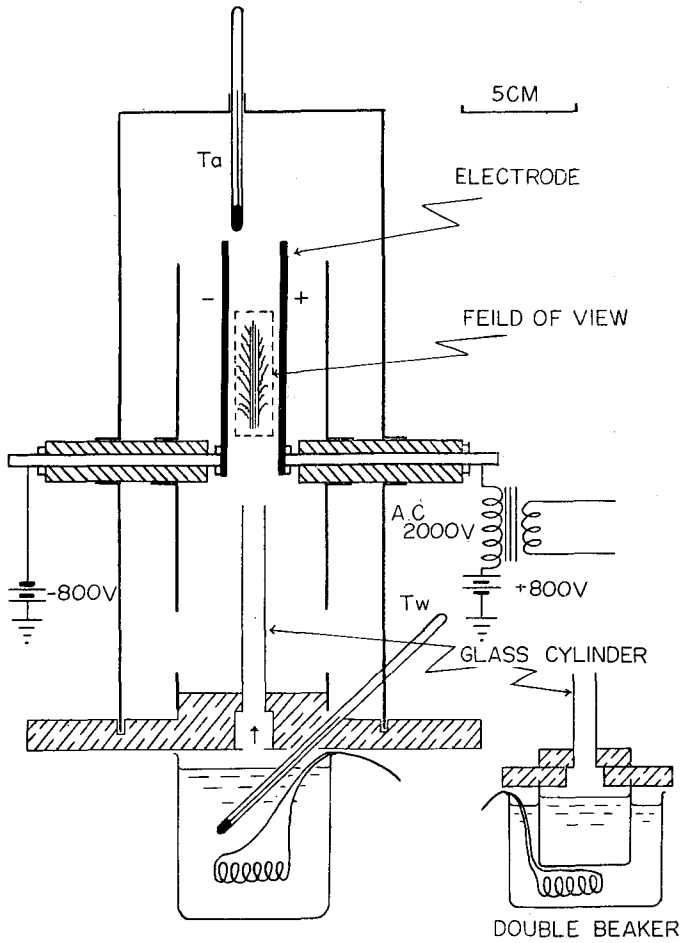

Fig. 5.

charge increases, and after T_w reaches about 80°C , the number of droplets with positive charge becomes roughly equal to that of negative droplets,

- iv) after T_w becomes higher than about 85°C , the number of negative droplets decreases.

Those results agree qualitatively with the results obtained in the experiment of dew electrifications, as shown in Figs. 2, 3 and 4. The number of droplets charged seems to decrease when T_w becomes higher than 90°C , as

shown in the right hand picture of Pl. III.

It is well known that impurities in water have predominant effects on the electrification phenomenon of droplets. As the next step in this work, therefore, distilled water was used instead of tap water. The electrification behavior of distilled-water droplets is shown in Pl II. In the pictures, one sees that the number of positive droplets is roughly equal to that of negative droplets when T_w is lower than 50°C . In the lower temperature range, distilled water shows a distinct contrast to tap water, but when T_w is higher than 80°C , distilled water droplets have positive charge as tap water droplets have. The process of electrification of distilled water droplets was also ascertained by means of the electrification of dew; results are shown in Fig. 6. In the figure, as one sees, the potential of the dew was predominantly positive as T_w ascended to 80°C , and after T_w reached 85°C , the potential descended.

The employment of such a method for producing droplets as described

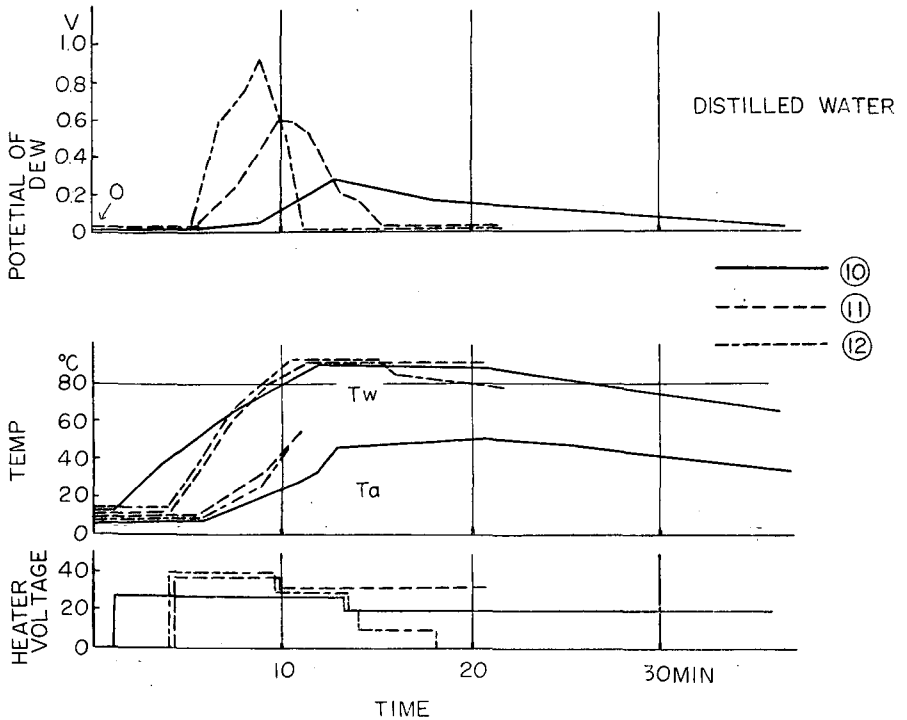

Fig. 6.

above, renders it difficult to produce droplets without charge. Droplets seem to be charged when bubbles burst from the water surface. In order to avoid the electrification of droplets, it is, therefore, desirable to supply water vapor without any production of bubbles. So, the water reservoir was changed for double beaker type as shown in the right lower part of Fig. 5. By the use of the double bottom beaker, local heating was avoided. Even if the double beaker was used, a few bubbles were occasionally produced in the inside of the bottom of the inner beaker, but as time lapsed and temperature became higher, no bubbles were observed. Individual droplets were not electrified at any temperature range, as shown in the left pictures, in Pl. III, although numerous droplets without charge were seen. Those droplets are considered to be particles condensed from water vapor.

Considering the results obtained by various types of heating, it seemed that droplets with negative charge were produced when small bubbles ascended to the water surface from the bottom at a relatively low temperature, while droplets with positive charge are produced when the droplets were

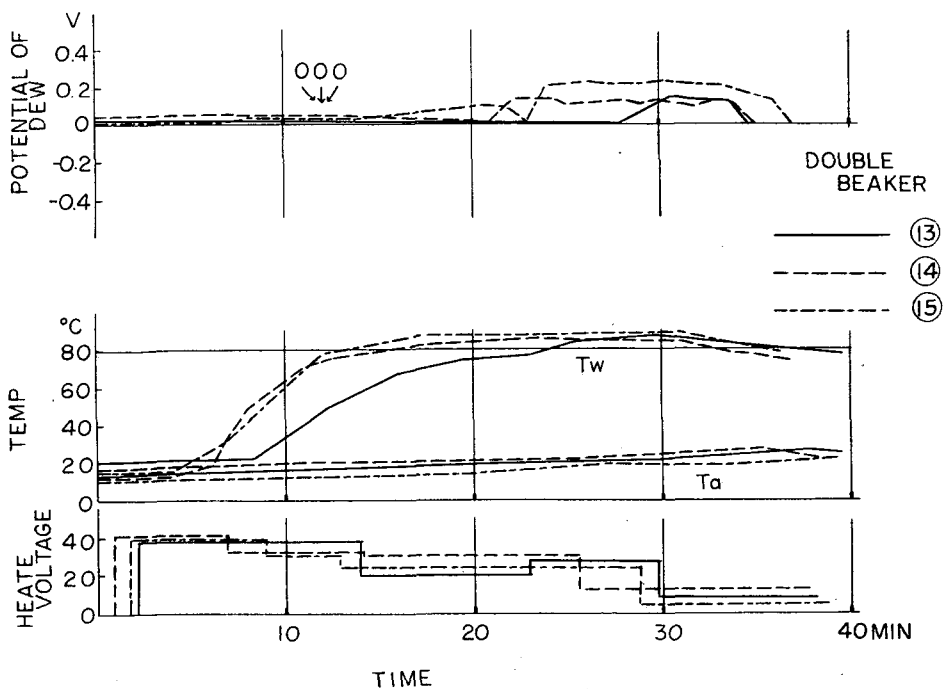

Fig. 7.

originated from the bursting of large bubbles on the water surface at the relatively high temperature. The fact that particles produced by the double beaker methods have no charge was also ascertained by the dew electrification experiment, as graphed in Fig. 7. But as one sees, the dew was slightly electrified positively when T_w was higher than 80°C . The electrification of the dew in this temperature range leads to the conclusion that it was brought about by some mechanism other than by the original charge of droplets. Anyhow it is possible to avoid the electrification of droplets if T_w is kept lower than 80°C in this double beaker.

In the experiments, it was desirable to ascertain the magnitude of charge on individual droplets. However, Stokes' Law could not be applied for determining the mass of individual droplets, since the droplets did not fall at their terminal velocities, but they were moved by the convective air current. Instead of using their fall velocities, the width of tracks of droplets was used to measure the size of the droplets, although the accuracy of the measurement was scarcely satisfactory. By this method, the diameter of the droplets was estimated to be from 20 to 50μ and their charge was estimated to have a magnitude of the order 10^{-5} e.s.u. This quantity is much larger than that of droplet charge reported by Blanchard⁸⁾, and is comparable to the larger charge on natural cloud particles measured by Twomey.⁹⁾

5. Conclusion

The experiment revealed that the charge on droplets produced artificially usually has considerable effect on the electrification of dew or frost, although the mechanism by which the droplets are electrified is not understood exactly. It is the authors' opinion that by what method the water droplets are produced, in other words, whether the droplets are originally electrified or not, is a severe problem in any experiment on the rime electrification phenomenon. A similar problem should arise in any studies on the electrification of natural graupel or hails.

The expense of this work was defrayed from the Special Fund for Scientific Research of the Education Ministry of Japan.

References

- 1) Findeisen, W. and E. Findeisen: Untersuchung über die Eissplitterbildung an Rief-Schichten. *Met. Z.*, **60** (1943), 145-154.
- 2) Weickmann, H.K. and H.J. aufm Kampe: Preliminary experimental results concerning charge generation in thunderstorms concurrent with the formation of hailstones. *J. Met.*, **7** (1950), 404-405.

- 3) Lueder, H. : Ein neuer elektrische Effect bei der Eisbildung durch Vergraupelung in natürlichen unterkühlten Nebeln. *Z. Angew. Phys.*, **3** (1951), 247-287.
- 4) Meinhold, H. : Die elektrische Ladung eines Flugzeuges bei Vereisung in Quellwolken. *Geophys. u. appl.*, **19** (1951), 176-178.
- 5) Reynolds, S.E., N. Brooks and Mary Foulks Gourley : Thunderstorm charge separation. *J. Met.*, **14** (1957), 426-436.
- 6) Chalmers, J.A. : Atmospheric Electricity. Pergamon Press, (1957), 42.
- 7) Nakaya, U. : The formation of ice crystals. *Compendium of Meteorology*, Amer. Met. Soc., (1951), 207-222.
- 8) Blanchard, D.C. : Electrified droplets from the bursting of bubbles at air-sea water surface. *Nature*, **175** (1955), 334-336.
- 9) Twomey, S. : The electrification of individual cloud droplets. *Tellus*, **8** (1957), 445-452.

Tracks of Water Droplets Produced from Tap Water under Electric Fields

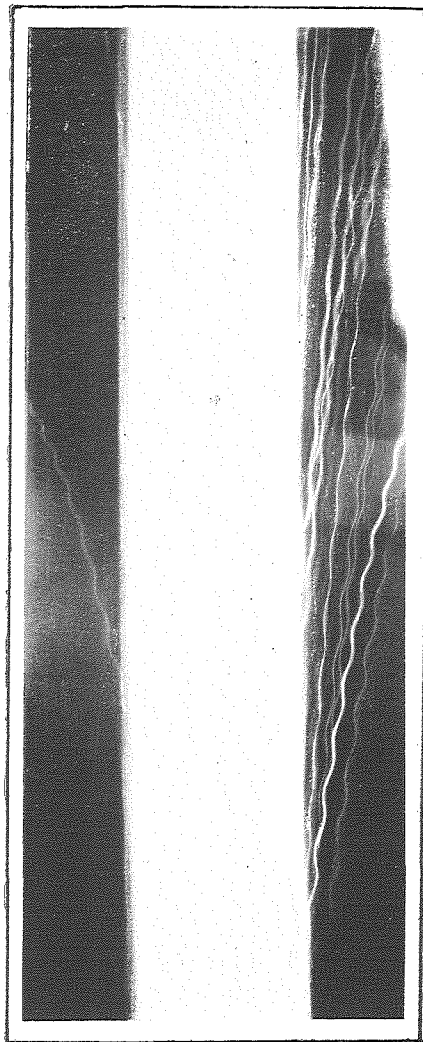

Tw: 51°C

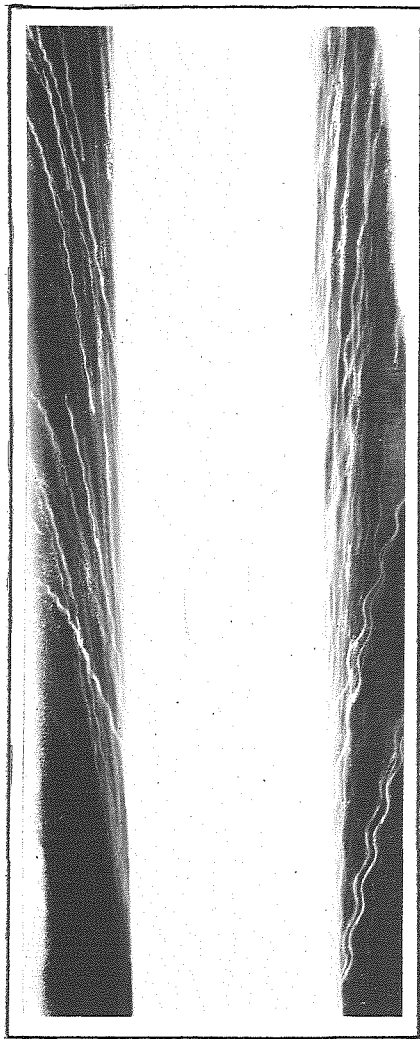

81°C

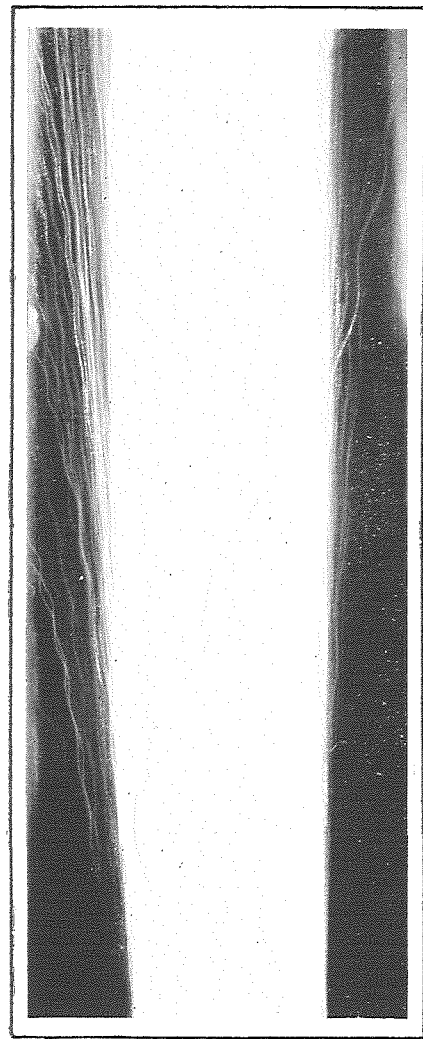

86°C

Tracks of Water Droplets Produced from Distilled Water under Electric Fields

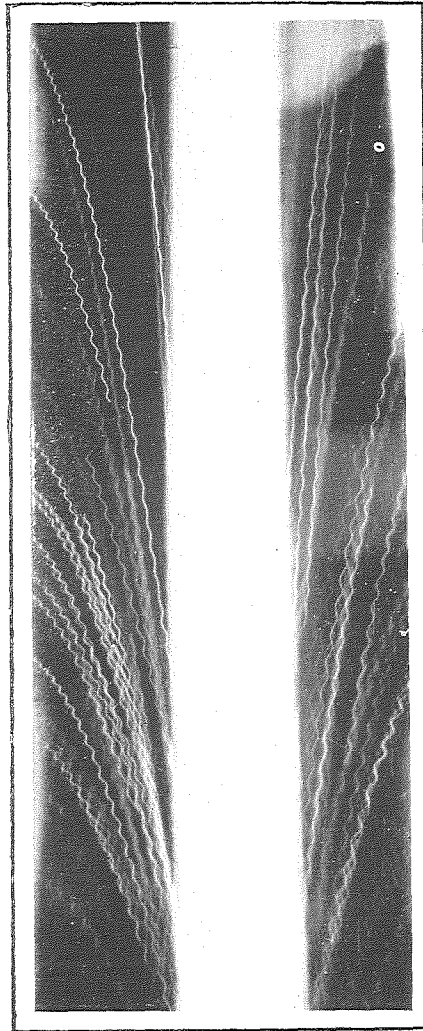
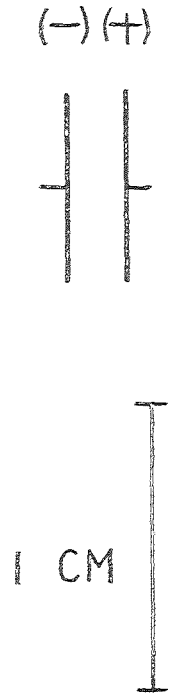

Tw: 46°C

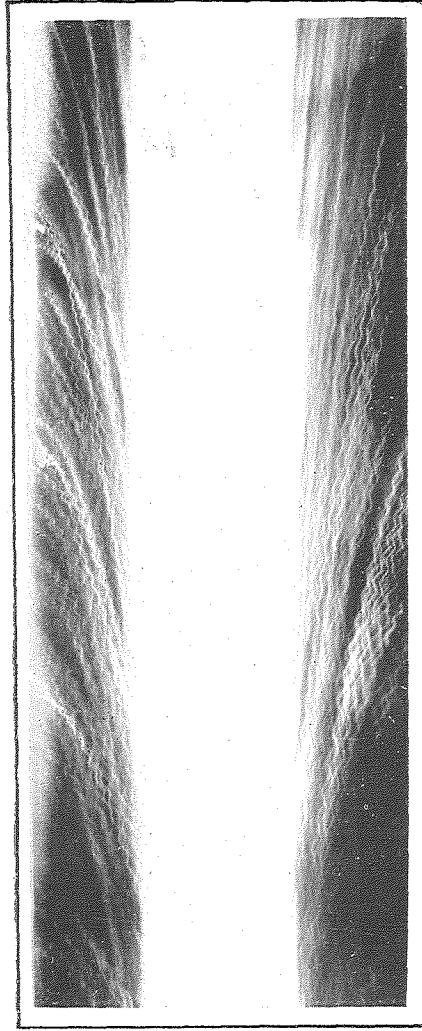

80°C

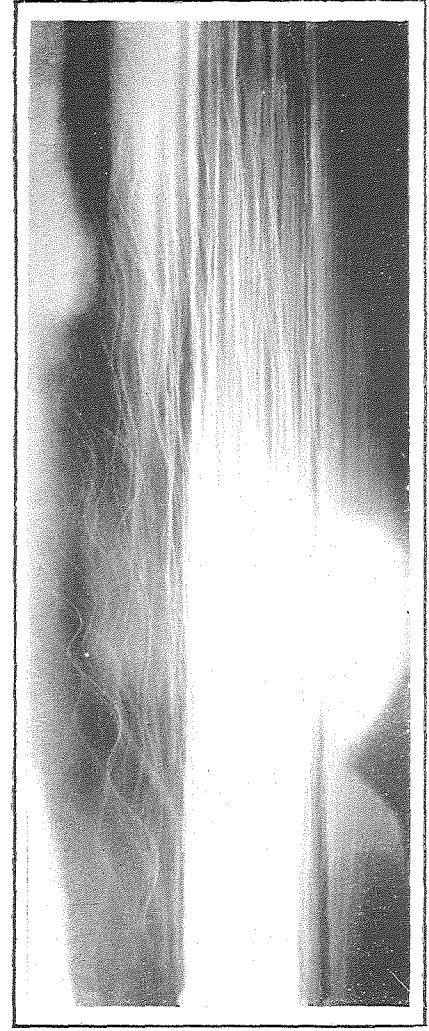

85°C

Track of Water Droplets under Electric Fields
Produced by Double Beaker Method

Produced from Tap Water

(-)(+)



1 CM

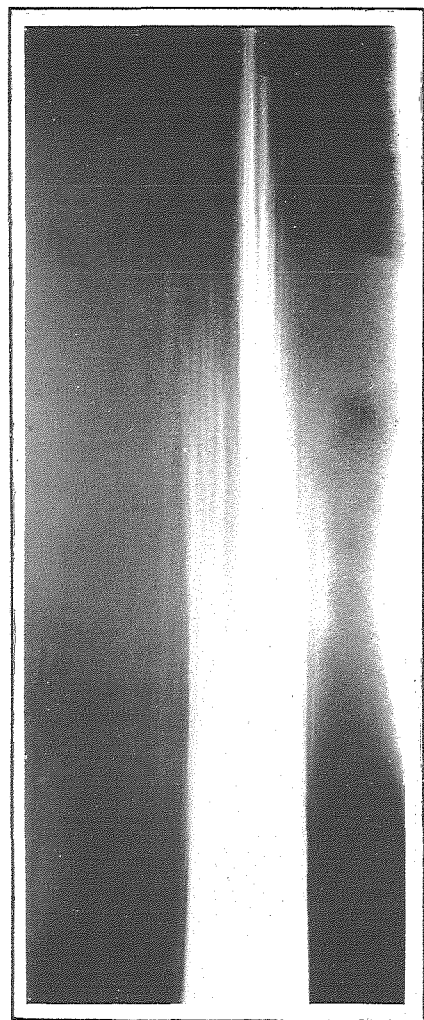

Tw: 53°C

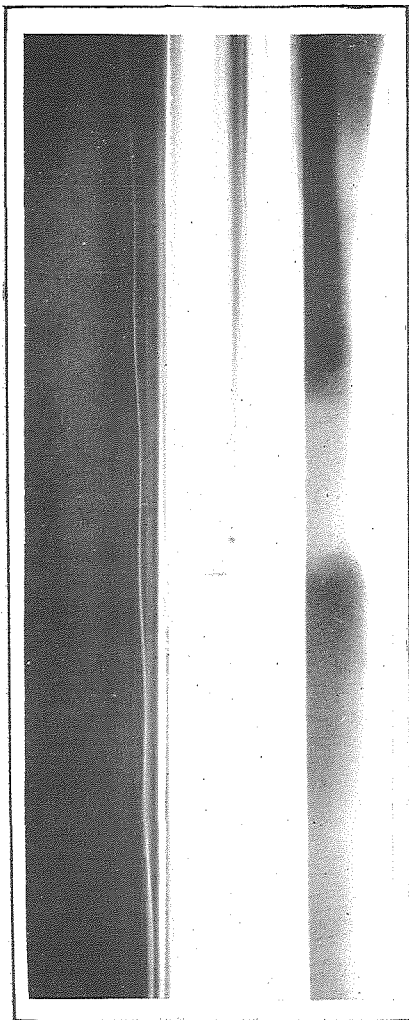

85°C

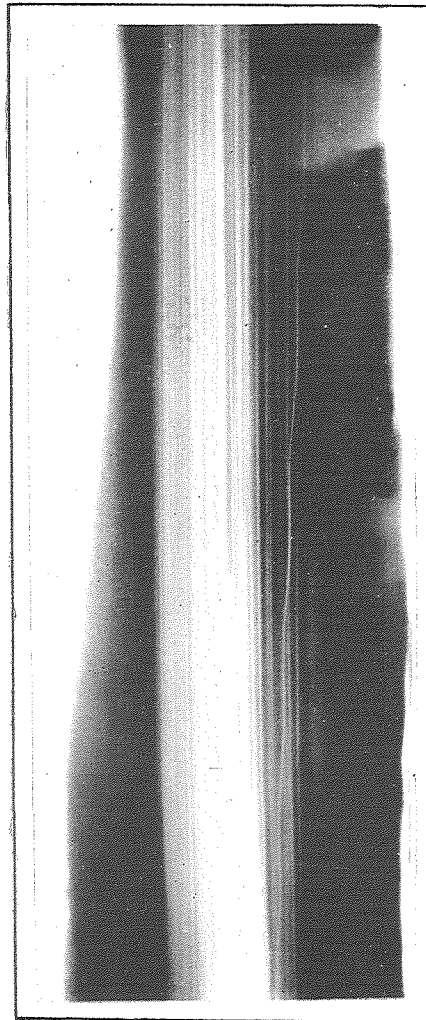

90°C