



# HOKKAIDO UNIVERSITY

Title	Etching of Ice Crystals by the Use of Plastic Replica Film
Author(s)	HIGUCHI, Keiji; MUGURUMA, Jiro
Citation	Journal of the Faculty of Science, Hokkaido University. Series 7, Geophysics, 1(2), 81-91
Issue Date	1958-11-05
Doc URL	<a href="https://hdl.handle.net/2115/8622">https://hdl.handle.net/2115/8622</a>
Type	departmental bulletin paper
File Information	1(2)_p81-91.pdf



## Etching of Ice Crystals by the Use of Plastic Replica Film\*

Keiji HIGUCHI and Jiro MUGURUMA

(Received June 7, 1958)

### Abstract

The etching of ice crystals using a plastic replica film was applied to many kinds of ice in nature. As described in the previous papers, the separated etch pits can be produced by coating the ice surface with a replica film of polyvinyl formal and keeping it in the cold chamber. The samples used in this work are pond ice, glacier ice, snow crystals, ice crystals in water, ice filaments grown from soil or a plant (*Keiskea japonica* v. *hodensis*). By these applications, it was confirmed that this etching technique is a simple and useful method for determining the crystal axes of ice grains.

### 1. Introduction

In the various fields of researches on natural ice such as glacier ice and river ice and the many other processes of freezing, it has been an important problem to record the grain structure of ice. The grain structure can be specified by the following two elements; the size distribution of ice grains and the orientation of crystal axes of individual grains. The methods for recording the size distribution were devised by Seligman<sup>1)</sup>, Ahlman and Droessler<sup>2)</sup>, and Schaefer<sup>3)</sup>. The orientation of *c*-axis has been determined by the use of crossed polaroids. Recently, Nakaya<sup>4)</sup> developed a simple method which made the determination of *a*-axis possible, by making Tyndall figures or vapor figures inside of single crystals of ice. In recent experiments, the senior author<sup>5)6)</sup> succeeded in producing the separated etch pits on the ice surface by a simple operation using a plastic replica film. These etch pits provide a reliable indication of the orientation of crystal axes of ice, as well as of many other crystals. Combining this etching technique with Schaefer's replica method, a simple method has been proposed for simultaneous observation of the size distribution and the orientation of crystal axes of ice grains<sup>7)</sup>.

In the present paper, some examples of the application of this etching technique will be described.

\* Investigations on the Etching of Ice Crystals No. 3.

## 2. Procedures for etching

The etching technique can be applied either to cases of a polished surfaces or to the natural surface of ice. In this paper, for examples of the former such materials as pond ice and glacier ice were used, for the latter, snow crystals and ice filaments grown from soil. For the case of the polished surface of ice, the procedures for the etching are as follows. The ice samples are sawed from a large block of ice, for example from commercial ice or from pond ice. One face of the ice sample is reduced to a plane by sawing and then is polished with sand paper. The slight unevennesses of the surface are removed by polishing with a piece of silk, after melting a thin layer of the surface. The polished ice surface is coated with a 1~5% solution of polyvinyl formal dissolved in ethylen dichloride<sup>3)</sup>. After a while, the solvent evaporates and the plastic replica film covers the surface of the samples, adhering closely to it. Leaving this covered sample in the air unsaturated with respect to ice, numerous separated etch pits are produced on the surface of ice. These etch pits are examined under a microscope and photographed. It is desired to carry out

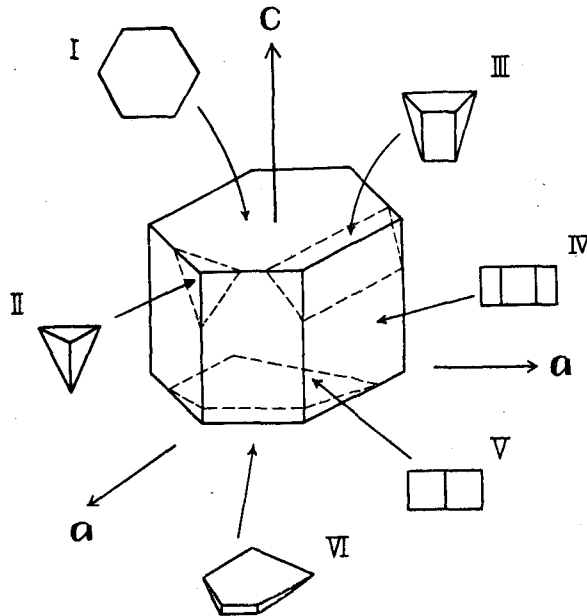

Fig. 1. Schematic diagrams of various shapes of etch pits.

these operations at a temperature of about  $-10\sim -20^{\circ}\text{C}$ . For the case of the natural surface of ice, the operation of polishing is not performed, but the natural surface is coated immediately with the replica solutions. The subsequent operations are the same as in the former case. The time necessary for the mature development of the etch pits depends upon the concentration of the replica solution used. When the temperature of the chamber was about  $-20^{\circ}\text{C}$  and the solution was 3%, nearly half a day was necessary before the mature stage was reached. In general, it can be said that the more dilute the solution the shorter the time.

The geometrical shapes of the etch pits belong to a hexagonal system, as shown in Fig. 1, which is reproduced from the previous paper<sup>6)</sup>. As seen in this figure, the orientation of the crystal axes of the ice grain could be determined from the shape of etch pits developed on the surface of it.

### 3. Application of etching technique

The above described etching technique was applied to the following samples of ice in nature, a) pond ice, b) glacier ice, c) snow crystals, d) ice crystals in water, e) ice filaments grown from soil, f) ice filaments grown from a plant (*Keiskea japonica* v. *hondensis*).

In these experiments, the etching operations were carried out in the cold chamber, in which the temperature of the air was about  $-20^{\circ}\text{C}$  except for the special cases, as noted by  $\theta$  in the explanation of the photographs. In each case, the elapsed time after coating with the replica film till photographing is shown in the explanation of the photographs respectively, being noted by  $t$ .

#### a) Pond ice

The samples were obtained from the natural ice, which had grown on the water surface of a pond after freezing during a cold night in winter. Photo. 1, Pl. I; shows the appearance of this ice in the natural state before sampling. Since a thin layer of this ice surface was melted by the sunshine in the morning, the grain boundaries of polycrystalline ice became visible with the naked eyes. These individual ice grains measured between 10 cm and 30 cm across, the thickness being about 0.5mm. The ice samples were sawed from this pond ice, and kept in the cold chamber. Using the 3% replica solution, the etching operation was applied to the surfaces of these ice samples. Photo. 2, Pl. I, shows the etch pits developed on a polished ice surface parallel to the frozen surface, and Photo. 3, Pl. I, shows those developed on the polished ice surface perpendicular to it. Since the shape of the etch pits in

the former case is type I and that in the latter is type IV in Fig. 1, it is concluded that  $c$ -axis of these ice grains is perpendicular to the water surface of the pond. This conclusion was confirmed by the observation of Tyndall figures<sup>4)</sup>, which were produced in the ice grains by the sunshine. From the comparison with the laboratory studies of freezing of water<sup>9)9)</sup>, the reason of such orientation as described above may be considered that the initiation of such freezing process was brought about by the stellar ice crystals floating horizontally on the water surface. Since  $c$ -axis of a stellar ice crystal is perpendicular to the base plane of it,  $c$ -axis of the ice grain grown from this floating stellar crystal would become perpendicular to the floating surface, that is, to the water surface of the pond.

On the other hand, radiating patterns were observed on the surface of the pond ice in some cases. Photo. 4, Pl. I, shows an example of this pattern of ice; the thickness was about 0.8 cm. The cross section of this ice was not flat, but skeleton-like, as shown in Fig. 2. The etching operation was applied

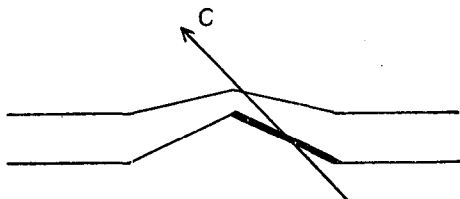

Fig. 2. Cross section of ice showing the radiating pattern.

to the basal surface of this ice, shown by the broad line in Fig. 2, using the 3% replica solution. The shape of the etch pits in this case is shown in Photo. 5, Pl. I. As the detailed studies about this case will be described in the other papers<sup>6)10)</sup>, only an outline of the observation is presented in this paper. Comparing Photo.

5, Pl. I, with Fig. 1, it is found from the shape of etch pit that  $c$ -axis of this ice grain is inclined to its surface at an acute angle, as shown in Fig. 2. In a typical case, it was determined by stereographic projection that the inclination of  $c$ -axis to the ice surface was  $22^\circ$ <sup>6)</sup>. Photo. 6, Pl. I, shows the etch pits of another ice grain in the same surface. Since the shape of the etch pits is type IV,  $c$ -axis of this grain was found to be parallel to the surface. The reason of such orientation of  $c$ -axis could not yet be determined from these few observations.

As seen in two examples described above, the orientation of the  $c$ -axis of the pond ice differs according to processes of freezing; the reason for this difference will be ascertained in the future researches of the freezing process of water.

### b) Glacier ice

The samples were obtained from the cores of the glacier ice, which were brought by Nakaya<sup>11)</sup> from the Greenland Ice Cap. The same etching operations as the case of *a*) were applied to the polished ice surface of these cores. In this case, after the coating with replica solution, the coated ice surface was covered with a sheet of paper, in order to control the speed of evaporation. Some examples of the etch pits in these cases are shown in Photos. 7~9, Pl. II. Since the observed samples were few, no conclusion could be obtained about the grain structure of glacier ice. However, it was interesting from the view point of crystallography to observe the crystal faces composing one of these etch pits. The etch pit, marked by A in Photo. 8, Pl. II, has a face slightly inclined to *c*-axis. In comparison with the pyramidal face as shown in Fig. 3, it may be considered that this crystal face is not the  $(10\bar{1}1)$  plane, but the  $(40\bar{4}1)$  plane, though the measurement of the interfacial angle could not be carried out. Just as the occurrence of the  $(40\bar{4}1)$  plane was rarely reported in the case of ice crystals,<sup>12)13)</sup> it was also very rare to observed

it in the case of etch pits. The occurrence of this high index crystal face may be one of the important problems related to the growth of ice crystals.<sup>14)</sup>

### c) Snow Crystals

The samples were artificial snow crystals both broad branched and sheath-like, which were produced in the experiments on the effect of aerosol particles on the shape of snow crystals, carried out by Nakaya and collaborators.<sup>15)</sup> After having been placed on a glass plate, the snow crystals were coated with the 3% replica solution, and then kept in the thermostat (32×25×29 cm), the temperature of the air being about -20°C. Photos. 10 and 11, Pl. II, show some examples of the etch pits developed on the basal surface of crystals of broad branches. As expected from the form of the crystals, the shape of these etch pits is hexagonal, their sides being parallel to *a*-axes of the snow

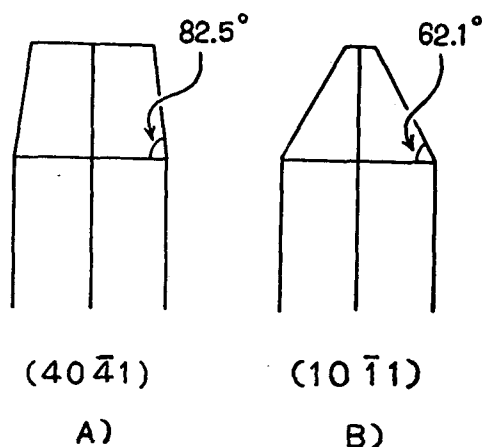

Fig. 3. Interfacial angle between crystal faces of ice.

crystal.

In some case, it was found that the layer patterns on the basal surface of broad branches of snow crystal were not always parallel to the side of the etch pit, that is,  $a$ -axes. An example is seen in Photo. 10, Pl. II, and is shown schematically in Fig. 4. Similarly to the case of snow crystals, such layer patterns on the ice surface were reported by Arakawa<sup>16)</sup> in his studies on the

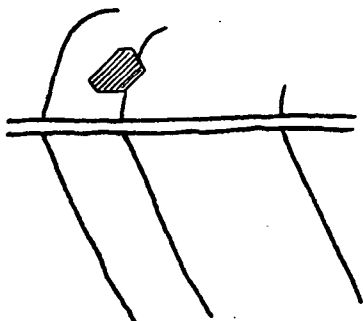

Fig. 4. Relation between the layer patterns of snow crystal and the etch pit.

ice crystals in water, by the senior author<sup>6)</sup> in his work on the etch pits, and by Ono<sup>17)</sup> in his experiments on the growth of hoar crystals. It could be observed in their photographs that the layer patterns in those cases were not parallel to  $a$ -axes of ice, similar to the present case of snow crystals. From these observations, the edge of this layer pattern seems to be a face composed of many crystal faces. On the other hand, the shape of this pattern may be related to the "liquid water" film on the ice surface,<sup>18)</sup> but decision could not yet be

arrived at experimentally.

*d) Ice crystals in water*

The etching of ice crystals in water was carried out by Arakawa<sup>19)</sup>, using the same operations as described above. A discoidal ice crystal grown in slightly supercooled water was taken from the water and placed on a glass plate. The etch pits on the basal plane of this crystal were developed by coating with 2% solution and keeping it in the cold chamber at about  $-25^{\circ}\text{C}$ . Photo. 12, Pl. II, shows the etch pits developed in the region near the periphery of the discoidal ice crystal, which is 2 mm diameter. This photograph is reproduced from Arakawa's paper. As these etch pits are regular hexagons, it may be stated that there is no crystallographic difference between these discoids and the ordinary hexagonal ice crystals.

*e) Ice filaments grown from soil*

By the employment of the same operations as in the case of snow crystals, the reproduction of the etch pits of ice filaments grown from soil was carried out in the following two cases. In the first case, the replica solution was coated on the surface of a bundle of ice filaments, which comprised many columnar ice grains. Photos. 13~15, Pl III, show the shapes of the etch pits

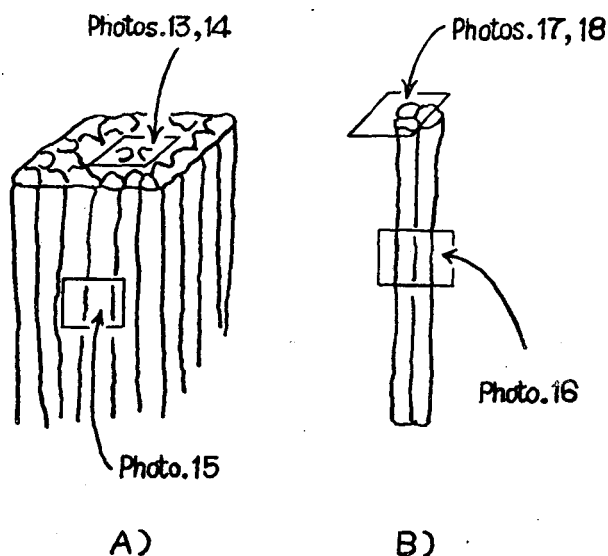

Fig. 5. Photographed parts of ice filaments grown from soil.

developed in this case; the arrow in Photo. 15 indicates the direction of growth of the ice filament. As shown in Fig. 5 A), the etch pits shown in Photos. 13 and 14 are those developed on the basal surface of the ice filaments, and the etch pits shown in Photo. 15 are those developed on the side surface of them. Since the shape of the etch pit in the former is type III and that in the latter is type V in Fig. 1, it is concluded that  $c$ -axis of the observed ice grains is nearly perpendicular to the direction in which the ice filaments was growing.

In the second case, the replica solution coating was applied to the surface of two or three ice filaments, which was separated from a bundle of ice filaments with a pincette. Photos. 16~18, Pl. III, show the shape of the etch pits in this case. As depicted schematically in Fig. 5 B), the etch pits shown in Photo. 16 are those developed on the side surface of columnar ice grains, and those in Photos. 17 and 18 are developed on the basal surface of them. In Photo. 16, since the shape of the etch pits is type I in Fig. 1,  $c$ -axis of the observed ice grain was determined to be perpendicular to the growth direction of the ice filaments. In photo. 17 are observed two ice grains. As the etch pits of type IV were observed in the right hand grain,  $c$ -axis of this grain was perpendicular to the growth direction. On the other hand, since

the etch pits in the left grain are of type III,  $c$ -axis of this grain was nearly perpendicular to the growth direction. In Photo. 18, three ice grains are observable. Since etch pits of type V were observed in the right hand grain,  $c$ -axis of this grain was perpendicular to the growth direction. Since the etch pits in the upper part of the left hand grains are type III,  $c$ -axis of this grain was nearly perpendicular to the growth direction. On the other hand, since etch pits of type I are observed in the lower part of the left grains,  $c$ -axis of this grain was determined to be parallel to the growth direction. These observations are summarized in Table 1. As same as the result obtained by Yoshida and Tsuboi<sup>20)</sup>

Table 1. Etch pits of ice filaments grown from soil.

No. of Photo.	Etched ice surface	Type of etch pits	Inclination of $c$ -axis to the growth direction
13	base	III	nearly $\perp$
14	"	III	nearly $\perp$
15	side	V	$\perp$
16	"	I	$\perp$
17 (r)	base	IV	$\perp$
17 (l)	"	III	nearly $\perp$
18 (r)	"	IV	$\perp$
18 (l)	"	III	nearly $\perp$
18 (l)	"	I	//

(r) : the right hand grain. (l) : the left hand grain.

from the examination by  $X$ -rays,  $c$ -axis of ice grains composing the ice filaments is perpendicular to the growth direction in many cases. Considering that  $c$ -axis of the snow crystals of column or needle types is parallel to their direction of growth, the following conclusion may be reached. The columnar ice grains composing ice filaments and the snow crystals of column or needle types are similar in shape, but they are quite different in the crystal structure.

f) *Ice filaments grown from a plant (Keiskea japonica v. hondensis)*

*Keiskea japonica* MIQUEL var *hondensis* NAKAI is a plant known as "Shimobashira-sô" (plant of ice filaments) in Japan. This popular name arises from the property of this plant that an ice filaments grows from a stem of it in the cold season. Some examples of this ice filaments are shown in Photos. 19 and 20, Pl. IV. Photo. 19 shows the natural state of it and Photo. 20 shows the state after separation of ice filaments from a stem. The same etching operations as the case of snow crystals were applied to the three surfaces of this ice filament. In this case, the temperature of the air was  $-10^{\circ}\text{C}$ . As indicated schematically in Fig. 6, Photo. 21, Pl. IV, shows the etch pits developed on the side surface of the ice filaments, while Photo. 22, Pl.

IV, shows those developed on the upper surface of it. Photo. 23, Pl. IV, shows those developed on the surface of a cross section. As seen in these photographs, an ice filament grown from the stem of the plant comprised many small ice grains, in each of which the types of the etch pits were different. It was impossible, therefore, to find any systematic relation between  $c$ -axis of the ice grain and the direction of growth of the ice filament.

#### 4. Summary

The etching technique using plastic replica film was applied to several kinds of ice in nature, viz., pond ice, glacier ice, snow crystals, ice crystal in water, ice filaments grown from soil or a plant. It was confirmed that this etching technique is a simple and useful method for determination of crystal axes of ice. Though these operations in these cases were carried out in the cold chamber, it will be easy to apply this etching technique in the field works of glaciology and hydrology.

Concerning the orientation of crystal axes of ice, the conclusions in each case are summarized as follows.

1)  $C$ -axis of ice grains composing a sample of pond ice is not always perpendicular to the water surface, but differs according to the freezing process.

2) A crystal face considered as a  $(40\bar{4}1)$  plane was observed in an etch pit developed on the surface of Greenland glacier ice sample (marked by A in Photo. 8, Pl. II.).

3) The layer patterns observed on the basal surface of the broad branch of snow crystals were not always parallel to  $a$ -axes, as shown in Photo. 11, Pl. II, schematically in Fig. 4.

4) In many cases,  $c$ -axis of columnar ice grains composing ice filaments grown from soil was nearly perpendicular to the growth direction of it, but not always so. It was found, therefore, that the columnar ice grains

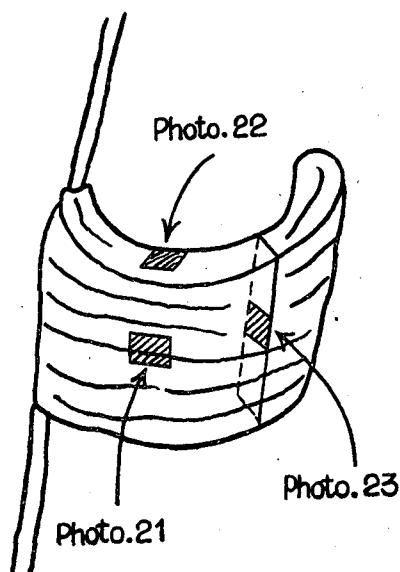

Fig. 6. Photographed parts of the ice filament grown from a plant.

composing ice filaments and the snow crystals of column and needle types are similar in shape, but that they are quite different in crystal structure.

5) In the case of ice grains composing the ice filament grown from a plant (*Keiskea japonica* v. *hondensis*), no conclusion could be reached about the relations between *c*-axes of them and the direction of growth of the ice filament.

In conclusion, the authors wish to express sincere thanks to the officials of the Transportation Technical Research Institute for the use of the Low Temperature Laboratory. This work is a part of studies on snow and ice now in progress in the Nakaya Laboratory of Hokkaidô University. The authors' gratitude is expressed to Prof. U. Nakaya and Dr. M. Hanajima of Transportation Technical Research Institute for their personal encouragement and suggestions throughout this work. The authors are also indebted to Dr. K. Arakawa of Hokkaidô University, who gave permission to reproduce in this paper a photograph (Photo. 12, Pl. II) taken by him.

#### References

- 1) Seligman, G.: The growth of the glacier ice, *J. of Glaciology* **1** (1949) 254-267.
- 2) Ahlmann, H.W. and E.G. Droessler: Glacier ice crystal measurements at Kebnekajse, Sweden, *J. of Glaciology*, **1** (1949) 269-274.
- 3) Schaefer, V.J.: A new method for studying the structure of glacier ice, *J. of Glaciology*, **1** (1950) 441-442.
- 4) Nakaya, U.: Properties of single crystals of ice revealed by internal melting, S.I.P.R.E. Research Paper, 13 (1956).
- 5) Higuchi, K.: Artificial Stimulation of Rain. Pergamon Press, (1957), 386-389.
- 6) Higuchi, K.: The etching of ice crystals, to be published in *Acta Metallurgica*.
- 7) Higuchi, K.: A new method for recording the grain structure of ice, *J. of Glaciology*, **3** (1957), 131-132.
- 8) Arakawa, K. and K. Higuchi: Studies on the freezing of water, *J. Fac. Sci., Hokkaidô Univ., Ser. II*, **4** (1952), 201-208.
- 9) Arakawa, K.: The growth of ice crystals in water, *J. of Glaciology*, **2** (1955), 463-464.
- 10) Muguruma, J.: to be published.
- 11) Nakaya, U.: to be published in *J. Fac. Sci., Hokkaidô Univ., Ser. II*, (1958).
- 12) Dana, E.S.: *The System of Mineralogy*, John Wiley & Sons, 6th ed. (1920): 1134, 7th ed. (1955), vol. I, 834.
- 13) Goldschmidt, V.: *Atlas der Krystallformen*, Carl Winters Universität Buchhandlung, (1916), Band **3**, 80.
- 14) Wolff, G.A.: The growth of ice crystals, *Artificial Stimulation of Rain*. Pergamon Press, (1957), 332-339.
- 15) Nakaya, U. et al.: to be published.
- 16) Arakawa, K.: Studies on the freezing of water (II), *J. Fac. Sci., Hokkaidô Univ., Ser. II*, **4** (1954), 331-339.

- 17) Ono, T.: On a growing and sublimating mechanism of ice, *Low Temperature Scienc. Ser. A*, **16** (1957), 27-29, (in Japanese).
- 18) Nakaya, U., and A. Matsumoto: Simple experiment showing the existence of "Liquid water" film on the ice surface, *J. of Colloid Science*, **9** (1954), 41-49.
- 19) Arakawa, K.: Studies on the freezing of water (III), *J. Fac. Sci., Hokkaidô Univ., Ser. II*, **4** (1955), 355-357.
- 20) Yoshida, U. and S. Tsuboi: Examination of ice-crystals by X-rays, *Mem. Coll. Sci., Kyoto Imp. Univ., Ser. A*, **12** (1929), 203-208.

## List of photographs

Plate	Photo. No.	Item	Magnification
I	1	Appearance of the pond ice	
	2	Etch pits developed on the ice surface parallel to the frozen surface	× 54.5
	3	Etch pits developed on the ice surface perpendicular to the frozen surface	× 93.5
	4	Appearance of the radiating patterns of surface of the pond ice	× 0.5
	5	Etch pits developed on the basal surface of the pond ice showing the radiating patterns	× 93.5
	6	ditto	× 32
II	7	Etch pits developed on the surface of the cores of glacier ice of Greenland Ice Cap	× 120
	8	ditto	× 120
	9	ditto	× 120
	10	Etch pits developed on the surface of snow crystal of the broad branches	× 120
	11	ditto	× 120
	12	Etch pits developed on the surface of the discoidal ice crystal in water (After Arakawa)	× 53
III	13	Etch pits developed on the surface of ice filaments grown from soil. The photographed part is shown in Fig. 5.	× 93.5
	14	ditto	× 93.5
	15	ditto	× 93.5
	16	ditto	× 69.5
	17	ditto	× 69.5
	18	ditto	× 69.5
IV	19	Ice filaments grown from a stick of the plant ( <i>Keiskea japonica v. hondensis</i> )	
	20	ditto, after separating ice filament from a stick of the plant	
	21	Etch pits developed on the surface of ice filaments grown from a stick of the plant. The photographed part is shown in Fig. 6.	× 40
	22	ditto	× 40
	23	ditto	× 40.5

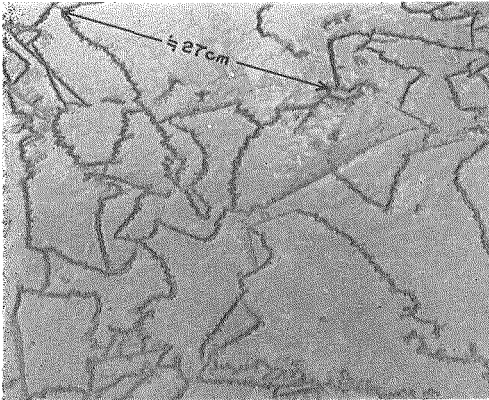

1

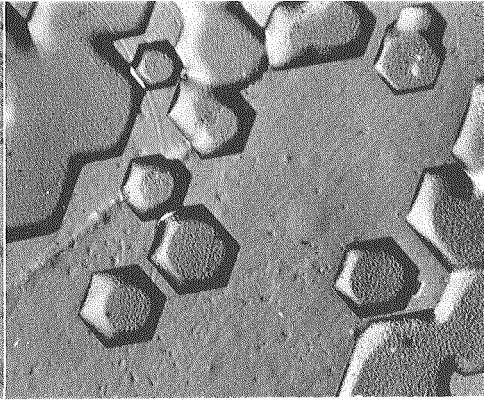

2  $\theta = -25^{\circ} \sim -30^{\circ} \text{C}$   $\times 54.5$   
 $t = 32\text{h } 10\text{m}$

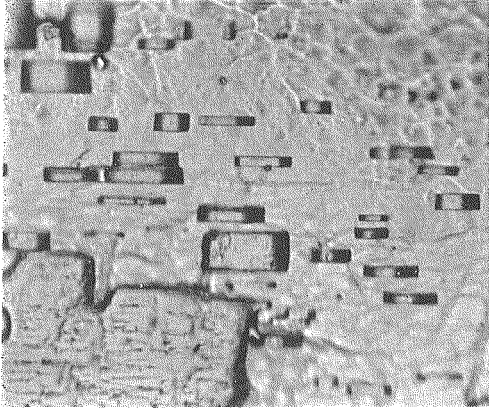

3  $\theta = -25^{\circ} \sim -30^{\circ} \text{C}$   $\times 93.5$   
 $t = 19\text{h}$

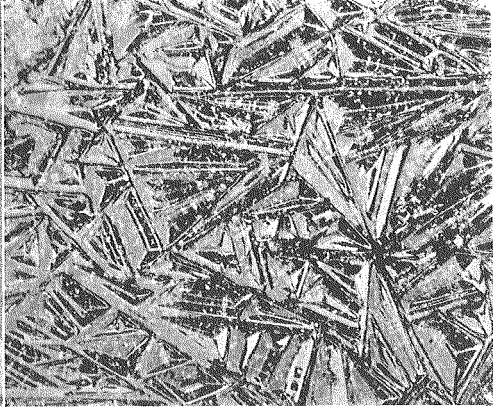

4  $\times 0.5$

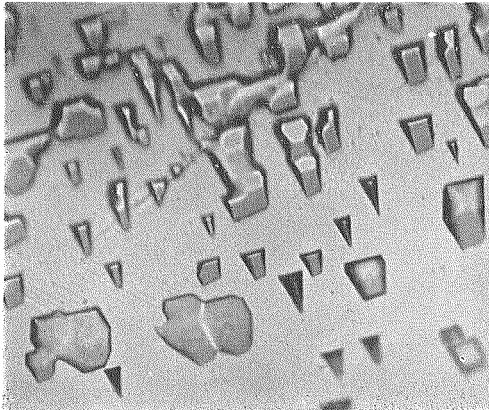

5  $\theta = -25^{\circ} \text{C}$   $\times 93.5$   
 $t = 15\text{h } 10\text{m}$

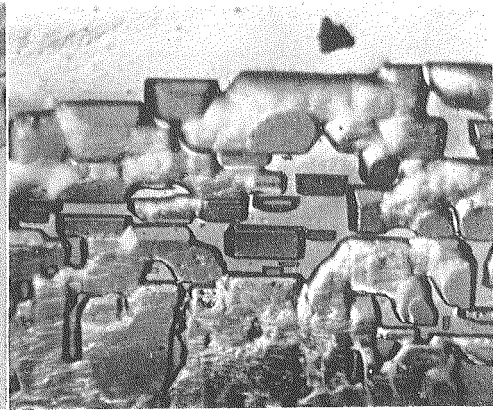

6  $\theta = -25^{\circ} \text{C}$   $\times 32$   
 $t = 118\text{h } 10\text{m}$

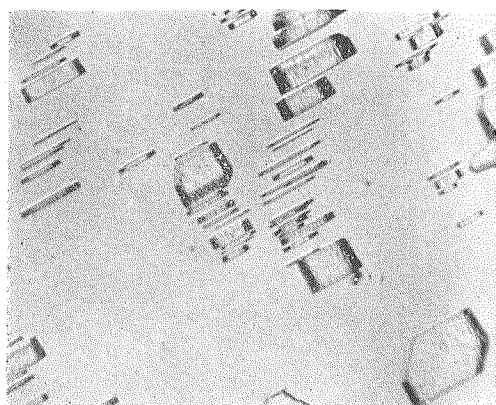

7  $\theta = -25^{\circ}\text{C}$   $\times 120$   
 $t = 24\text{h}$

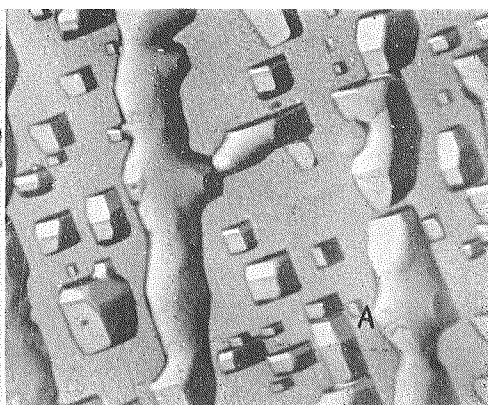

8  $\theta = -25^{\circ}\text{C}$   $\times 120$   
 $t = 24\text{h}$

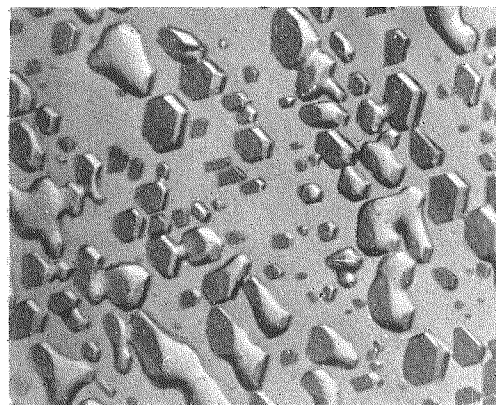

9  $\theta = -25^{\circ}\text{C}$   $\times 120$   
 $t = 24\text{h}$

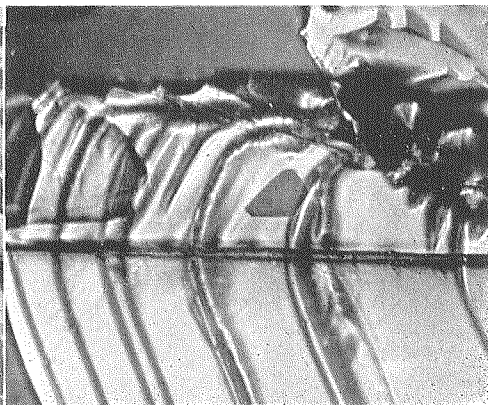

10  $\theta = -20^{\circ}\text{C}$   $\times 120$   
 $t = 17\text{h } 25\text{m}$

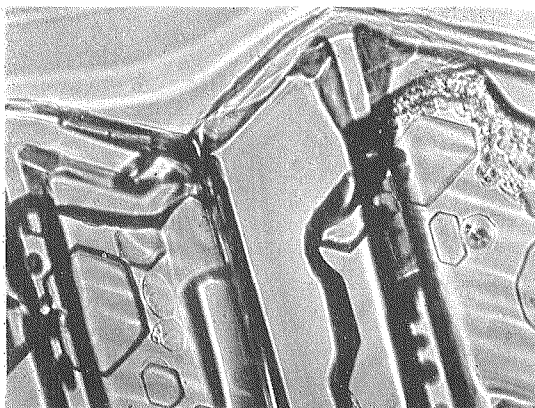

11  $\theta = -20^{\circ}\text{C}$   $\times 120$   
 $t = 17\text{h } 25\text{m}$

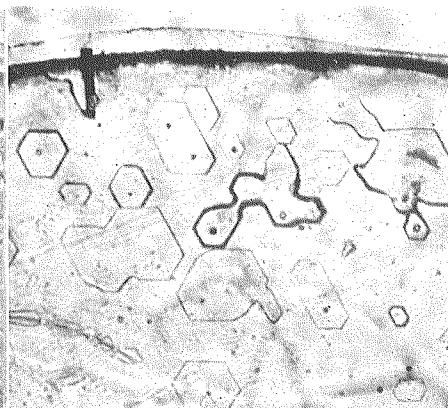

12  $\theta = -25^{\circ}\text{C}$   $\times 53$   
(After Arakawa)

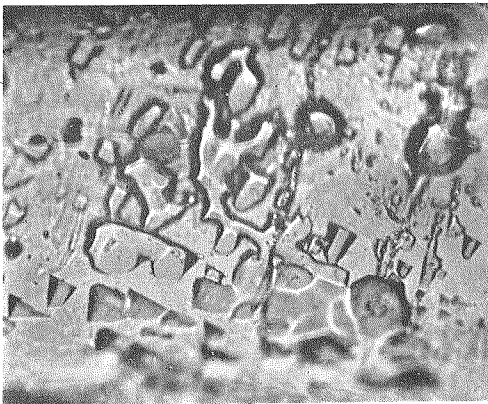

13  $\theta = -22^{\circ}\text{C}$   $\times 93.5$   
 $t = 1\text{h } 45\text{m}$

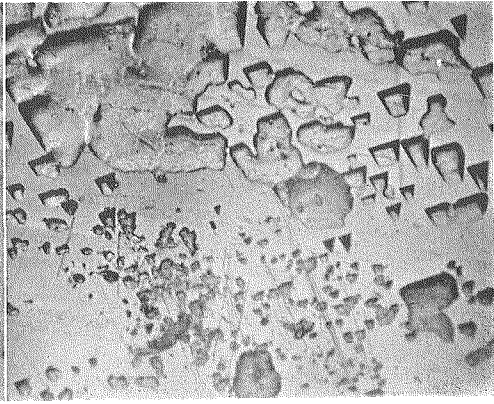

14  $\theta = -22^{\circ}\text{C}$   $\times 93.5$   
 $t = 19\text{h } 40\text{m}$

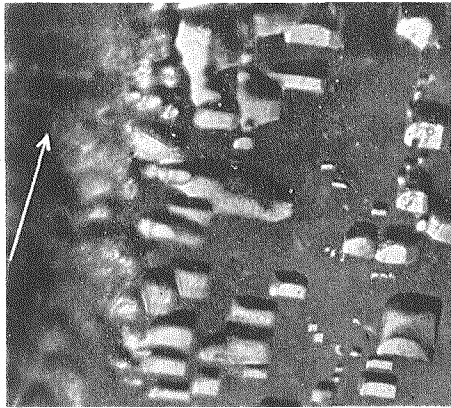

15  $\theta = -22^{\circ}\text{C}$   $\times 93.5$   
 $t = 1\text{h } 45\text{m}$



16  $\theta = -15^{\circ} \sim -20^{\circ}\text{C}$   $\times 69.5$   
 $t = 4\text{h } 10\text{m}$

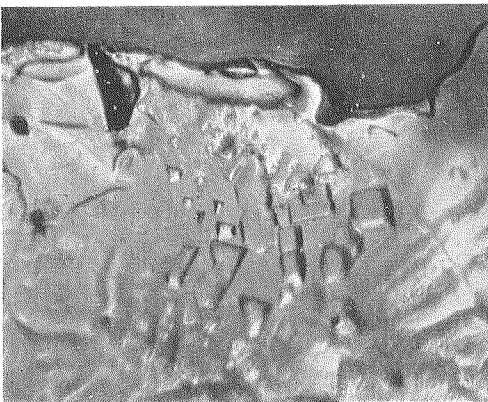

17  $\theta = -15^{\circ} \sim -20^{\circ}\text{C}$   $\times 69.5$   
 $t = 5\text{h}$

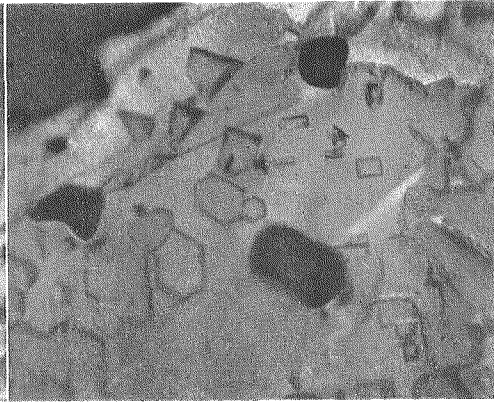

18  $\theta = -15^{\circ} \sim -20^{\circ}\text{C}$   $\times 69.5$   
 $t = 5\text{h}$



19

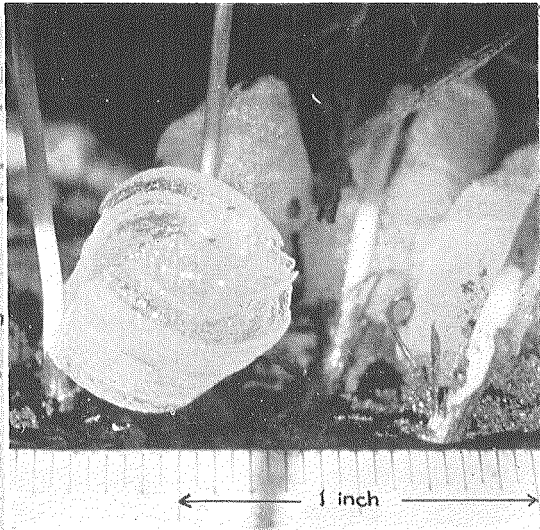

20

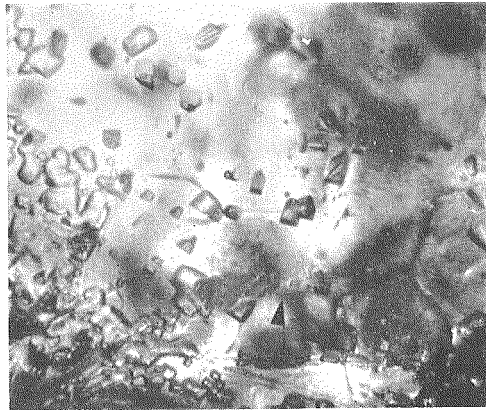

21

$\theta = -10^{\circ}\text{C}$   
 $t = 2\text{h } 45\text{m}$

$\times 40$

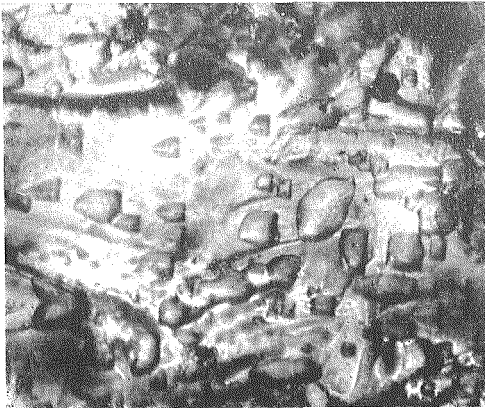

22

$\theta = -10^{\circ}\text{C}$   
 $t = 3\text{h}$

$\times 40$

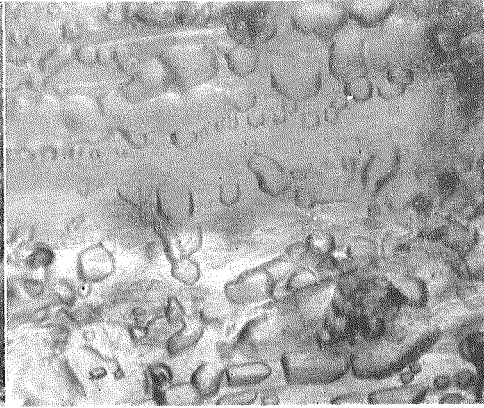

23

$\theta = -10^{\circ}\text{C}$   
 $t = 3\text{h } 45\text{m}$

$\times 40.5$