



HOKKAIDO UNIVERSITY

Title	Electric Polarity of Graupel Particles
Author(s)	KIKUCHI, Katsuhiro; INATSU, Kazuo
Citation	Journal of the Faculty of Science, Hokkaido University. Series 7, Geophysics, 6(1), 21-30
Issue Date	1980-03-31
Doc URL	https://hdl.handle.net/2115/8700
Type	departmental bulletin paper
File Information	6(1)_p21-30.pdf



Electric Polarity of Graupel Particles

Katsuhiko KIKUCHI and Kazuo INATSU*

(Received Oct. 1, 1979)

Abstract

Observations taking note of the electric polarity of graupel particles were carried out in the mid winter monsoon season of 1976 on the coast of Ishikari Bay near Sapporo, Hokkaido. Especially, attention was paid to the condition of precipitating graupel particles, that is to say, whether the graupel particles were precipitating with other snow particles or not, and whether the surface of graupel particles was dry or wet, namely, whether they were soft hail or small hail or not. As a result, in 7 cases except for 1 case, almost all graupel particles were charged positively, and they were dry and coexisted with a number of small snow particles. In an exceptional case, on the other hand, almost graupel particles were charged negatively. In this case, although the graupel particles were dry, they precipitated alone without small snow particles or fragments. Therefore, it was concluded that positive polarity of dry graupel particles (soft hail) resulted from the collision and friction with a number of small snow particles or the disintegration of fragile surface of graupel particles. This result coincided with the former observational results¹⁾ and experimental results^{13),14)}.

1. Introduction

Electric charge, particularly, polarity of graupel particles will give vital information for the understanding of the mechanisms of charge generation in the electrified clouds and thunderclouds. Because, graupel particles are always included in the precipitation particles falling from strong electrified snow clouds. There were, however, only a limited observational results regarding the electric polarity of graupel particles till the present.¹⁾⁻⁴⁾

Furthermore, in the observational results, they did not describe the condition of the graupel particles, that is to say, whether the graupel particles were precipitating with other snow particles or not, and whether the surface of graupel particles was dry or wet, namely, whether or not they were soft hail or small hail. Because, it is well known that electrification occurs during the melting process of the ice specimen in laboratory experiments.⁵⁾⁻¹²⁾ On the other hand, Magono and Takahashi¹³⁾ and Takahashi¹⁴⁾ concluded that electrification of riming depends on the liquid water content and temperature

* Nippon Denshi Kagaku Co., Ltd.

from their riming experiments. Therefore, observations of electric polarity of graupel particles considering the surface condition and precipitating condition are necessary.

2. Observation equipment

In the observations carried out till the present, a collector (plate) method was used.¹⁾⁻⁴⁾ In the case of graupel particles, however, at times the rebound of graupel particles on the collector (plate) has been recognized. Further, when the chart speed of the recorder used is slow or the precipitation intensity is strong, the record of each charge overlaps with each other. And when the amount of charge is large, overshoots of records are recognized. In the cases as described above, although a general tendency of time change of charge is estimated, it is difficult to clarify the exact features of charge as

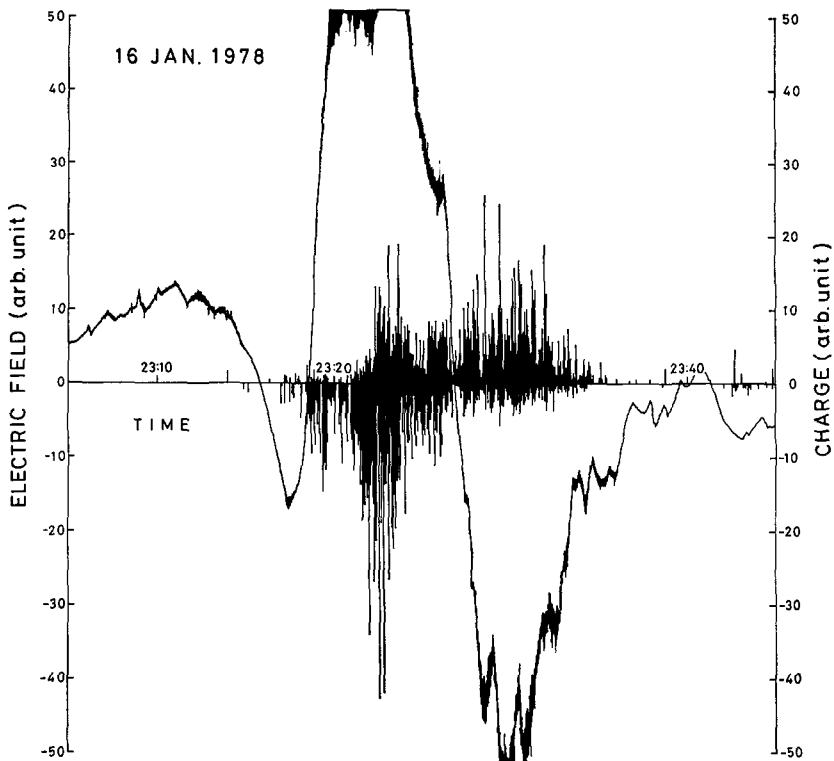

Fig. 1 Time change of atmospheric electric field strength and electric charges on precipitation particles measured by the collector (plate) method.

shown in Fig. 1. As the rebound of graupel particles newly generates electrification on the collector, an induction ring method was adopted (Fig. 2). In this equipment, the maximum absolute charge of precipitation particles was memorized by a peak hold system such as Bradley and Stow¹⁶⁾, which is controlled by a timing controller. Gate times of the timing controller are 0.5, 1, 2, 10, and 30 seconds. And the gate time was selected depending on the precipitation intensity. The maximum charge of precipitation particles during the selected gate time is digitized and printed out through an A-D converter with time. Furthermore, the maximum charge of precipitation particles and atmospheric electric field strength can be recorded on a dual channel recorder or magnetic tape of a data recorder. The measuring

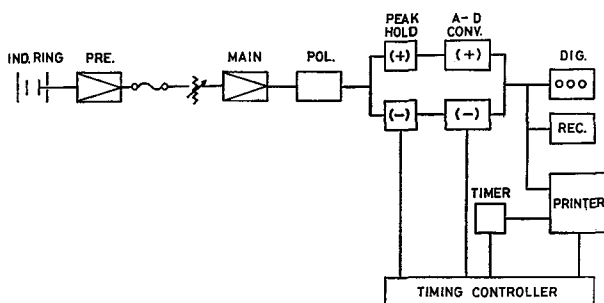

Fig. 2 Block diagram of an induction ring method.

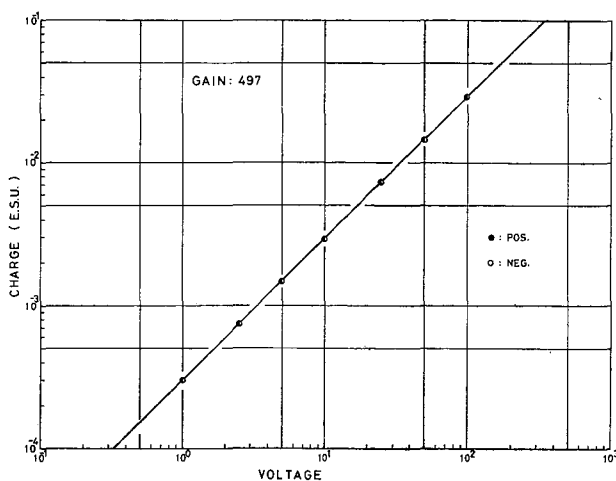

Fig. 3 Calibration curve of charge versus applied voltage.

margin of this equipment was three figures from 1×10^{-4} to 1×10^{-1} esu at each dial setting. The linearity of the amount of charge was very good as shown in Fig. 3. An example of the simultaneous records of the maximum charge of precipitation particles during 10 seconds of the gate time and the electric field is shown in Fig. 4.

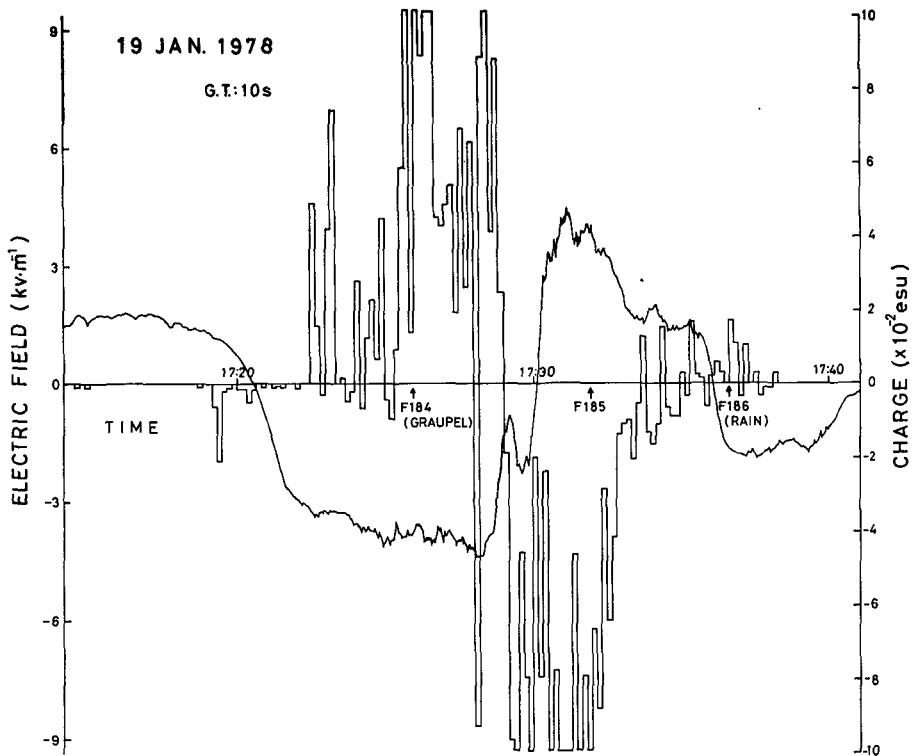

Fig. 4 Time change of atmospheric electric field strength and electric charges on precipitation particles measured by the induction ring method at a gate time of 10 seconds.

3. Observation results

In general, it has been said that the electric polarity of graupel particles is positive predominantly. On the other hand, however, there are a few meteorologists who insist that the predominant polarity of graupel particles is negative. Then, we carried out simultaneous observations of electric charge, shape and condition of graupel particles and electric field in the mid winter

monsoon season of 1976 on the coast of Ishikari Bay near Sapporo, Hokkaido. Results are shown in Fig. 5. In the figure, the left side column shows the time change of the amount of charge and electric field strength. The axis of the ordinate shows the amount of charge in esu, and the relative value and sign of electric field. The sign of electric field is positive at the upper part of the axis of the abscissa which expresses the time. The sign of electric charge is the same with that of electric field. The relative value of electric field is shown by solid and dashed lines with small arrows in the upper and lower sides of each figure. Solid lines indicate the values above 30 times of the normal fair weather value and dashed lines indicate the values below 30 times of the normal fair weather value. As the gate time is 10 seconds in all cases, each dot shows the amount of the maximum charge of precipitation particles passed through the induction ring during 10 seconds. In the case of January 18, although the measuring range adopted was between 1×10^{-4} and 1×10^{-1} esu, it shows that a number of graupel particles recorded the charge above 1×10^{-1} esu.

On the coast of Ishikari Bay, in general, graupel particles were observed only a few minutes in advance of the main snowstorms. Therefore, the time duration of the figures selected here are only a few minutes when the graupel particles were recorded by Formvar replication method and a microscope. The time replicated graupel particles are shown by the letter R in each figure. Wind direction and velocity when the graupel particles were recorded are shown by a knot in each figure. The right side column shows the enlarged photographs of precipitation particles replicated. Replication method was not carried out in the case of January 15. The reduction of photographs is the same in all photographs and the scale is inserted in the top photographs.

In all cases observed, the surface condition of graupel particles was dry, that is to say, soft hail. As seen in all cases except for the case of 0910 JST January 23, positive charge was predominant and a mirror image relation between the signs of charge and electric field was maintained. In the case of 0910 JST January 23, on the other hand, although negative charge was predominant, the mirror image relation was maintained similarity.

Now, taking note of the precipitation condition of graupel particles replicated on the glass slides, graupel particles of 7 cases were recorded with other numerous small snow particles and fragments except for the case of 0910 JST January 23. Only in the case of 0910 JST January 23 alone, small snow particles and fragments were not recognized with graupel particles. In

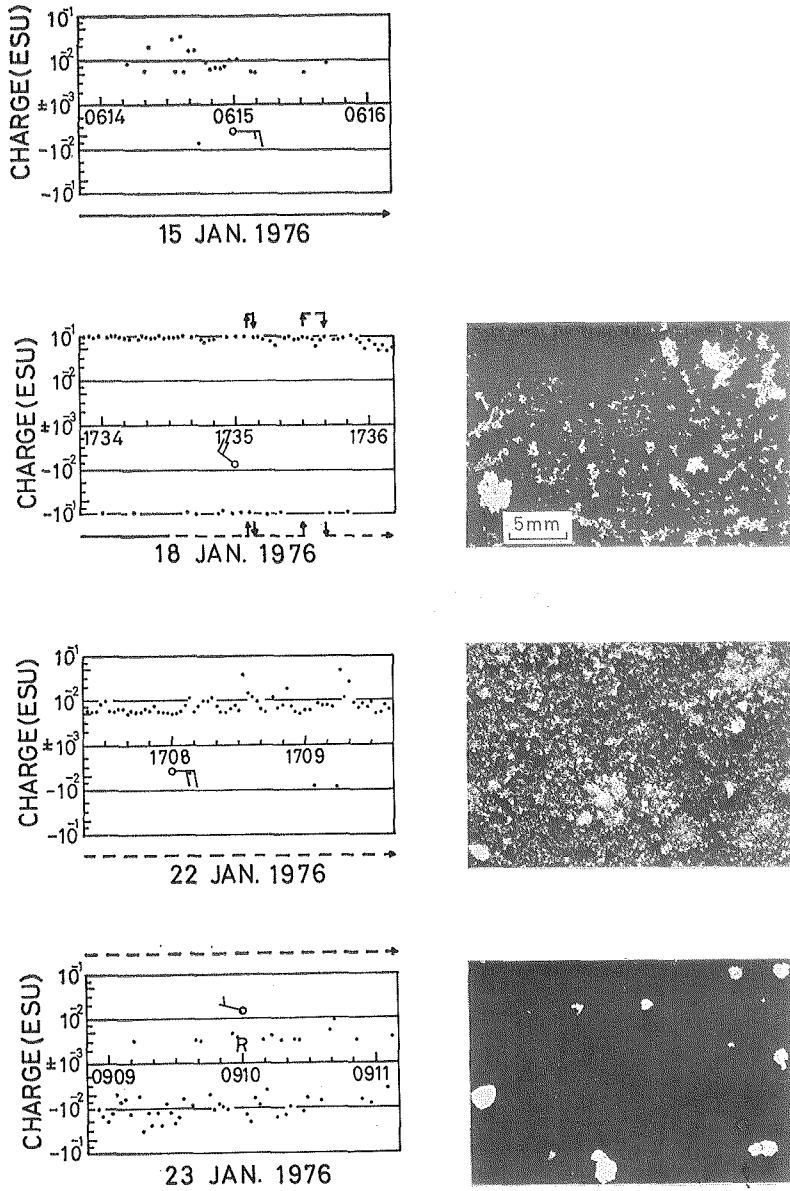

Fig. 5 Time changes of atmospheric electric field strength and electric charges on precipitation particles (left) and photographs of precipitation particles replicated on glass slides (right).

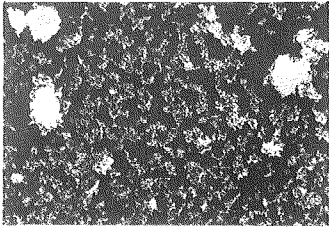
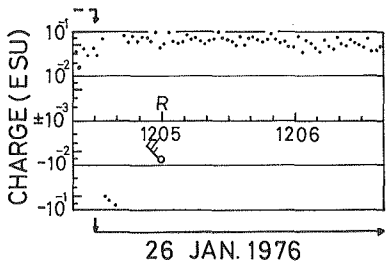
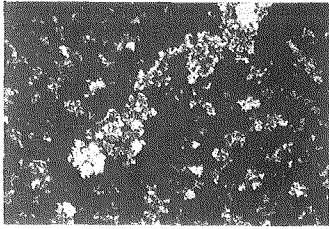
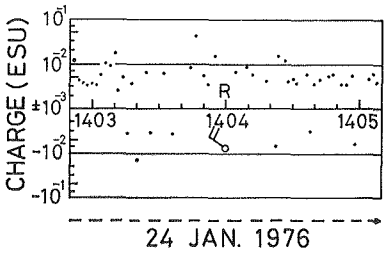
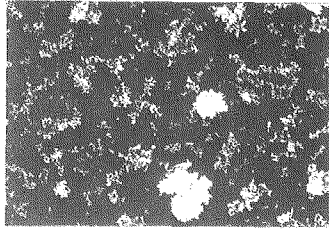
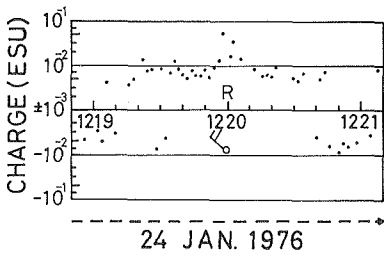
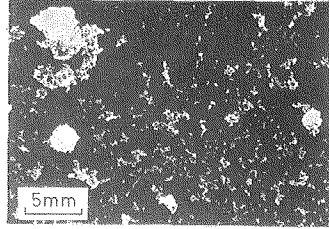
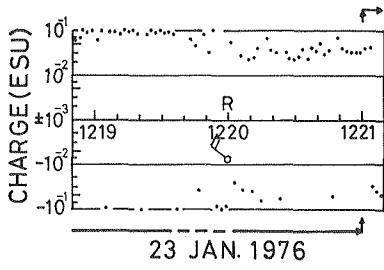

Fig. 5 (Continued)

this case negative graupel particles were predominant.

4. Consideration and conclusion

Previously, Kikuchi⁴⁾ observed that relatively large dendritic snowflakes, densely rimed crystals and graupel particles (soft hail) were positively charged under a negative electric field. Furthermore, he pointed out that when positive snowflakes and graupel particles fell, the mode value of the size distribution of melting diameters at that moment shifted to smaller sizes as compared with that when negative snow crystals fell alone. Based on these results, he concluded that relatively large snowflakes, densely rimed crystals and graupel particles were charged positively by collision and friction with small snow particles which were charged smaller than the margin of the measurement or by disintegration of small particles or fragments from fragile snowflakes and graupel particles.

In this observation, when the positively charged precipitating particles were predominant, densely rimed crystals and graupel particles coexisted with other small particles as seen in the photographs of glass slides replicated precipitating snow particles. On the other hand, when the negative charged particles were predominant, only the graupel particles alone existed as seen in the photographs of the case of 0910 JST January 23. Therefore, it was ascertained that the electric polarity of graupel particles (soft hail) is positive when they precipitated with other small snow particles. This is the most typical precipitation condition when the winter monsoon season prevailed. On the other hand, the electric polarity of graupel particles (soft hail) is negative when they precipitated alone.

Takahashi^{14),15)} carried out laboratory experiments to clarify the charging mechanisms of graupel particles from the existence of the electric potential produced at the boundary surface between the liquid water and bulk ice, and the riming electrification under the conditions of temperature and liquid water content. Based on his experiments, he considered a mechanism of the charge separation that at low liquid water content, where the riming probes are electrified positively, negatively electrified broken branches will be produced on contact with ice crystals. At the breaking point of the ice, dislocations will be formed and, at each dislocation site, a pair of free protons and negatively charged dislocations will be formed. The free protons produced move under a temperature gradient. During riming, as the latent heat is released, the temperature of the surface of the ice branches will be warmer so that protons

will move toward the interior the rime.

Therefore, broken ice branches will be electrified negatively while the rime will be electrified positively. His experimental results coincided with the present observational results.

Acknowledgments: This work was made as a part of the Project No. 046001 of "Experimental and Observational Studies on the Mirror Image Relation Between the Polarities of Precipitation Particles and Atmospheric Electric Field" in 1975 and 1976, and the Project No. 246033 of "Studies on the Atmospheric Electrical Properties of Precipitation Particles" in 1977 and 1978 under the Grant-in-Aid for Scientific Research (B), the Ministry of Education, Science and Culture of Japan.

References

- 1) ORIKASA, K.: On the disturbance of the surface electric field caused by rain and snowfall. *Geophys. Bull. Hokkaido Univ.*, **9**, (1962) 123-160. (In Japanese)
- 2) ISONO, K., M. KOMABAYASHI and T. TAKAHASHI: A physical study of solid precipitation from convective clouds over the sea: Part III. - Measurement of electric charge of snow crystals -. *J. Meteor. Soc. Japan*, **44**, (1966) 227-233.
- 3) MAGONO, C. and K. ORIKASA: On the disturbance of surface electric field caused by snowfall. *J. Meteor. Soc. Japan*, **44**, (1966) 260-279.
- 4) KIKUCHI, K.: Atmospheric electrical properties of snow clouds with precipitation. *J. Meteor. Soc. Japan*, **53**, (1975) 322-333.
- 5) MAGONO, C.: Precipitation electricity of thunderclouds and showerclouds. *Electrical Processes in Atmospheres*, Steinkopff, Amsterdam, (1977) 368-378.
- 6) DINGER, J.E. and R. GUNN: Electrical effects associated with a change of state of water. *Terr. Magn. Atmos. Elect.*, **51**, (1946) 477-494.
- 7) MAGONO, C. and K. KIKUCHI: On the positive electrification of snow crystals in the process of their melting. *J. Meteor. Soc. Japan*, **41**, (1963) 270-277.
- 8) MAGONO, C. and K. KIKUCHI: On the positive electrification of snow crystals in the process of their melting (II). *J. Meteor. Soc. Japan*, **43**, (1965) 331-342.
- 9) KIKUCHI, K.: On the positive electrification of snow crystals in the process of their melting (III), - The relationship between air bubble concentration and charge generated in ice specimen during their melting -. *J. Meteor. Soc. Japan*, **43**, (1965) 343-350.
- 10) KIKUCHI, K.: On the positive electrification of snow crystals in the process of their melting (IV), - Charge of droplets produced from bursting of air bubbles in ice specimen -. *J. Meteor. Soc. Japan*, **43**, (1965) 351-358.
- 11) KIKUCHI, K.: On the role of air bubbles in the electrification of melting ice. *Planetary Electrodynamics*, Gordon and Breach, (1969) 329-338.
- 12) DRAKE, J.C.: Electrification accompanying the melting of ice particles. *Quart. J. Roy. Meteor. Soc.*, **94**, (1968) 176-191.
- 13) MAGONO, C. and T. TAKAHASHI: On the electrical phenomena during riming and glazing in natural supercooled droplets. *J. Meteor. Soc. Japan*, **41**, (1963) 71-81.

- 14) TAKAHASHI, T.: Riming electrification as a charge generation mechanism in thunderstorms. *J. Atmos. Sci.*, **35**, (1978) 1536-1548.
- 15) TAKAHASHI, T.: Electric potential of liquid water on an ice surface. *J. Atmos. Sci.*, **26**, (1969) 1253-1258.
- 16) BRADLEY, S.G. and C.D. STOW: The measurement of charge and size of raindrops: Part I. The Disdrometer. *J. Appl. Meteor.*, **13**, (1974) 114-130.