



HOKKAIDO UNIVERSITY

Title	High Time-Resolved Observation of Triboluminescence of Crystalline Sucrose
Author(s)	MAEDA, Itaru
Citation	Journal of the Faculty of Science, Hokkaido University. Series 7, Geophysics, 7(3), 251-256
Issue Date	1983-02-10
Doc URL	https://hdl.handle.net/2115/8739
Type	departmental bulletin paper
File Information	7(3)_p251-256.pdf



High Time-Resolved Observation of Triboluminescence of Crystalline Sucrose

Itaru Maeda

*Research Center for Earthquake Prediction, Faculty of Science,
Hokkaido University, Sapporo 060, Japan*

(Received October 30, 1982)

Abstract

High time-resolved observation of triboluminescence was made for crystalline sucrose. A cleavage test along the plane (001) and a uniaxial compression test in which the load axis was perpendicular to the plane (001) were made.

Triboluminescence was observed simultaneously at the time cleavage began. The time lag between them is less than 10^{-7} sec. Intensity variation of the triboluminescence activity correlates with the load variation, though the correlation is not quantitative. In the uniaxial compression test, there are two cases. The one case is that a crack generation accompanies triboluminescence and acoustic emission. The other case is that a crack generation accompanies only an acoustic emission. This difference in the two cases is explained by the difference in crack mode (tensile or shear). It is also recognized that an observation of triboluminescence can be used to investigate fracture physics.

1. Introduction

Triboluminescence (TL) is the emission of light produced during mechanical action on solids. The TL phenomenon has been known for many years. Some kinds of investigations have been made and the results of these have been reviewed by Walton (1977) and Zink (1978). Many of them were chiefly concerned with measuring the spectrum of TL and identifying new TL materials. Therefore fracture techniques to obtain TL efficiently in these experiments are different far from those usually used in rock fracture experiments (see Walton, 1977). Among these experiments, there are some interesting ones. Alzetta et al. (1970) reported that the TL of some kinds of crystals reveals a feature, so called the Kaiser effect, under a cyclic loading in a bending test, and that a correlation exists between the variation of the TL intensity and the load change with respect time. These results are very similar to the relation between the number of acoustic emissions (AEs) and the load or the load change. Chandra and Zink (1980) reported an impact fracture experiment

of single crystals. In the report, they discussed a relation between the impact velocity, which relates to the total fractured area, and the TL intensity. In these cases, TL associates not to a single crack but to many branched cracks or to a complex fracture.

The intensity variation of TL as a function of time (glow curve) has also been studied, but the results obtained in the early stage of the TL investigation are not reliable (Walton, 1977) because of the low speed response of the photomultiplier tube used. The glow curves depend heavily on the fracture techniques. There is no investigation with sufficiently high time resolution, in which TL associates with a single crack. In spite of these defects, it seems that the investigation of TL can be used to study the physics of a crack or a fracture (Chandra and Zink, 1980).

In the present report, we first will investigate how the TL activity is associated with a single crack by the high time-resolved observation, and then discuss the relation between the TL activity and the load change and the AE activity during the fracturing process of a sample. Then we will try to confirm that the investigation of TL can be used to study the physics of fracture.

2. Experiment

The samples used were crystalline sucrose having a size of $2 \times 2 \times 4 \text{ mm}^3$. The mechanism which produces TL is already known (Walton, 1977). The sucrose crystals were cleaved along the plane (001) by a method similar to the Brazilian test. A uniaxial compression test, in which the loading direction was perpendicular to the plane (001), was also made. Fig. 1 shows the experimental system. The variation of load during the fracture process was

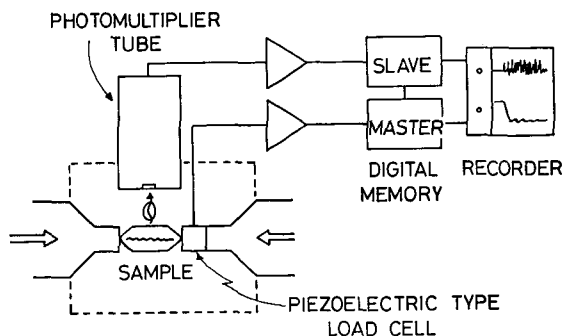

Fig. 1 Block diagram of the experimental system.

measured by a piezoelectric-type load cell directly attached to the sample. The cell was also used to detect AE. The response time of the cell is sufficiently short (less than 10^{-7} sec.) The output of the cell was received by an amplifier with an input impedance of 10^7 ohms. This means that the cut-off period was longer than 10^{-4} sec. and therefore long enough to detect the long term variation of load in the present study.

TL was detected by a photomultiplier tube (PM) (Hamamatsu TV, model R464). The pulse width of a photon pulse converted by this PM was less than 10^{-7} sec. Passing through a low pass filter (cut-off frequency is 4 MHz,) contiguous pulses were memorized by a digital memory after A/D conversion (sampling period was 5×10^{-8} sec). The load variation with respect time was also memorized in the other memory under a control of the same triggering logic as TL. Detail of this memory system has been described elsewhere (Maeda, 1979).

3. Results and discussion

We will describe results about the cleavage fracture first. Fig. 2 shows a typical record of the TL pulse train (upper trace) and the variation of load (lower trace). Each pulse on the trace does not correspond to a photon pulse exactly because of a low speed response of the recording system. This trace (pulse train) means that the emission of light began at the very time the load change began and that the light emission still continued even though the

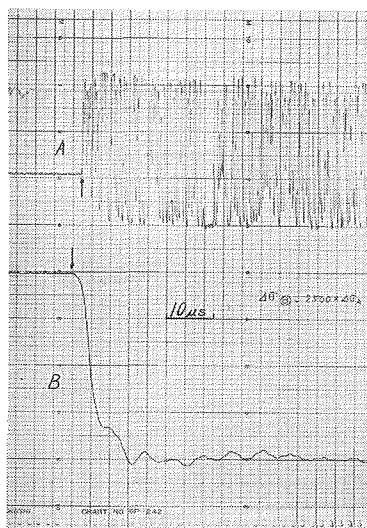

Fig. 2 An example of photon pulse train (trace A) and the load change (trace B), which shows that TL begins at the same time when the load change begins. The load drop begins at a point on trace B pointed by a down arrow. Because the recording pen of ch. B advances 1 div. against ch. A, the time pointed by the arrow on trace B corresponds to a point on trace A pointed by an up arrow. Reverberation can be seen on trace B.

load change had already ended (on this chart, the recording pens were not in the same position in the direction of the time axis and therefore the load trace advanced 1 div. ahead of the TL trace.). The time lag between the onset times of the TL activity and the load change could not be detected by the present measuring system. This means that the simultaneity of the onset times of the two phenomena is less than 10^{-7} sec.

The curve of the load change shows that it took about 10 microsec. to complete the sample fracture. A reverberation (AE) can be seen on this curve. The time duration of the TL activity is much longer than the process time of the cleavage fracture; it is also longer than the duration time of the reverberation though this cannot clearly be seen from Fig. 2.

The time duration of the TL activity is not exactly in proportion to the amount of the load change. This can be understood by considering the mechanism for TL emitted by sucrose crystals. The TL of sucrose is mainly caused by its piezoelectric characteristic (Walton, 1977; Zink, 1978) when sucrose is fractured in air. Although the main mechanism of discharge is a gas discharge between newly formed surfaces of a crack (Walton, 1977), there may be other type of discharge. The most effective one may be conduction through surfaces of a crack and the test machine. In this experiment, the sample was not isolated electrically from the test machine. The total amount of the electric current conducted must differ from sample to sample because the situations of the fractured samples are not the same. This made the duration time of the TL activity scattered.

A variation of the TL intensity cannot be measured by this system when the intensity is sufficiently high. This situation occurred when a crack propagated uniformly through the sample. In some cases, we were able to observe variations of the TL intensity during an irregular change of load. This variation of the TL intensity is exemplified by Fig. 3. In this case, a cleavage crack propagated through the sample at irregular intervals. In this figure, the relation between the change of the load and that of the TL intensity is obvious, though it is not quantitative, i.e. a propagation of a crack which results the load change stimulates the TL activity. This result about short term variation consists with the observation made by Alzetta et al. (1970) for rather long term relation between the TL intensity and the stress or strain change. It means that an observation of the TL activity can be used to monitor a fracture process as the AE can, as far as transparent materials are tested.

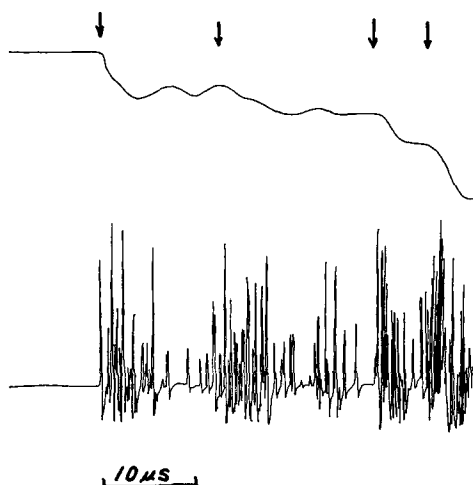

Fig. 3 An example of record which shows a correlation between the load change (upper trace) and the TL activity (lower trace). Arrows indicate times when the load begins to drop irregularly and the TL activity is stimulated.

For the uniaxial compression test, the situation is not as simple as the cleavage fracture case. Samples are not fractured along a simple plane as in the cases of the cleavage fracture. The complexity is promoted by the fact that cracked pieces of sucrose crystal weld with each other under stress. The welding never occurs with minerals except in cases of sufficiently high temperature and high confining pressure.

We examined by the uniaxial compression test a relation between the TL and the AE activity. Although there were no explicit breakdown of samples because of the welding, there were many small cracks and TL and AE were detected. We can classify these activities into two types. The first type is where TL and AE are observed simultaneously and the second is where only AE is observed. The second type of activity means that a small crack does not accompany TL but it emits AE. We can deduce from this fact that cracks belonging to the second type are shear ones because the shear cracks do not make the charge separation along surfaces of the cracks, which contrasts with the case of tensile cracks. Obviously the first type of activity is involved with tensile cracks. We can, therefore, determine the mode (tensile or shear) of a crack without determining the focal mechanism of a crack. To determine the focal mechanism of a crack in a sample is very difficult and no one had succeeded to obtain it with reliability.

Generally speaking, the duration time of the TL activity accompanying one AE is shorter than that of the cleavage fracture of crystals. This is explained by the fact that the path of electric current by conduction per unit area of a crack surface in the uniaxial compression case is wider and shorter than that of the cleavage case, which means that the charge produced by the piezoelectric effect is discharged during a shorter time interval in the former case.

4. Conclusions

1. In the case of the cleavage fracture of samples, the TL activity begins at the same time when the fracture begins. The time lag between them, if one exists, is less than 10^{-7} sec.
2. During fracturing process, the variation of the TL intensity correlates with the load change, though the correlation is not quantitatively expressed.
3. In the uniaxial compression test, two types of crack generation are observed. The one accompanies TL and AE and the other accompanies only AE. We can explain this observation as the crack mode of the former case is the tensile type and that of the latter is shear.
4. As far as the sample materials are transparent, an observation of the TL activity can be used, similarly to the AE, to study fracture physics.

References

- Alzetta, G., I. Chudacek, and R. Scarmozzino, 1970. Excitation of triboluminescence by deformation of single crystals, *Phys. Stat. Sol. (a)*, **1**, 775-785
- Chandra, B.P. and J.I. Zink, 1980. Triboluminescence and the dynamics of crystal fracture, *Phys. Rev. B.*, **21**, 816-826
- Maeda, I., 1979. On the recording and processing system for AE (in Japanese), *Zisin*, **32**, 233-241
- Walton, A.J., 1977. Triboluminescence, *Adv. Phys.*, **26**, 887-948
- Zink, J.I., 1978. Triboluminescence, *J. Amer. Chem. Soc.*, **11**, 289-295