



HOKKAIDO UNIVERSITY

Title	The Balloon Observation Techniques Utilized for the Studies of Electric Structure in Winter Thunderclouds of Japan
Author(s)	TANIGUCHI, Takashi; ENDOH, Tatsuo
Citation	Journal of the Faculty of Science, Hokkaido University. Series 7, Geophysics, 7(4), 281-294
Issue Date	1984-02-29
Doc URL	https://hdl.handle.net/2115/8742
Type	departmental bulletin paper
File Information	7(4)_p281-294.pdf



The Balloon Observation Techniques Utilized for the Studies of Electric Structure in Winter Thunderclouds of Japan

Takashi Taniguchi

*Department of Geophysics, Faculty of Science,
Hokkaido University, Sapporo 060, Japan*

and

Tatsuo Endoh

*Solid Precipitation Physics Section, Institute of Low Temperature Science,
Hokkaido University, Sapporo 060, Japan*

(Received October 31, 1983)

Abstract

In order to investigate the role of precipitation particles in the electrification mechanism in winter thunderclouds, corona discharge current and electric charge on precipitation were measured simultaneously by a specially designed electric sonde.

Since the corona discharge current varies over a wide range in clouds, input sensitivities were changed in succession. The measured values of corona discharge current were translated into electric potential gradient using calibrations, and the total space charge was deduced by Poisson's equation from the electric field under some assumptions.

In several test balloon flights, three complete sets of profiles of two electric elements were obtained although they contained some complicated cases.

The measurable range of corona discharge current was 2×10^{-10} to 2×10^{-5} A, which corresponds to 10^2 to 10^4 V/m of electric potential gradient, and sufficiently large compared with the variation of corona discharge current in the cloud. The detectable amount of electric charge on precipitation was 10^{-3} e.s.u. .

1. Introduction

To investigate the electric structure in thunderclouds, some particular elements of atmospheric electricity have been often measured by means of a free balloon method.

Simpson and Scrase (1937) measured the antenna current in thunderclouds using "alti-electrograph", and deduced the profile of vertical electric potential

gradient.

On the basis of the same principle, Belin (1948) and Chapman (1958) measured the same electric element by means of a radiosonde method.

On the other hand, Takahashi (1965) designed a radiosonde for measuring the electric charge on precipitation and observed the distribution of electricity in winter clouds, based upon the assumption that the precipitation had the most important role in electrification process of thunderstorms.

Recently, Winn et al. (1978) reported a successful and dramatic case study in which they measured both the vertical and horizontal components of the electric field in thunderclouds by a specially designed radiosonde, and they also followed the precise path of the sonde and obtained the precipitation echoes around the flight path by the aid of two radars.

Takahashi (1978) designed several kinds of special sondes for measuring the electric elements in warm clouds. These all are expected to present considerable variable information in cloud electricity. However, these data contain many measured values at different times and along different paths in many stages of life cycles of the clouds, as a result, it seems slightly difficult to compare these data and discuss the relationships among them. Therefore, a simultaneous measurement of several kinds of elements in cloud electricity are necessary in order to obtain more precise analyses and arguments.

It is widely accepted that precipitation has an important role in the electrification mechanism in thunderstorms. To verify this concept, investigations were focused on obtaining the distribution of both the vertical component of electric potential gradient and electric charge on precipitation respectively along the vertical line. The former may be translated into the distribution of total space charge along the vertical line, using Poisson's equation under the assumption of horizontal homogeneity. Then it becomes possible to compare the total space charge and the precipitation charge at same position in clouds.

The present authors have carried out simultaneous measurements of electric potential gradient and electric charge on precipitation particles by means of an electric field sonde and a precipitation charge sonde respectively, over these several years. The sondes were connected to the same balloon in such a way that each sonde would pass through the exact same flight path in clouds. However, this method has some problems. The electric field sonde was a field mill type. Thus, it had some mechanical parts (rotating sector and synchronous detector) which were vulnerable to shocks during launching under a strong wind. Furthermore, the total weight was large because each sonde had independent transmitters with carrier wave frequencies of 1680 MHz and 400 MHz respec-

tively. At the ground site, two sets of receivers and pen recorders were necessary, which caused difficulty and complicated handling in launching.

As the another method to measure the electric field strength, a radio-isotope equalizer has been used. But it has become impossible to use it for a free balloon.

Hence, the corona discharge current method was selected to deduce the electric potential gradient because this method dose not require mechanical parts or radio-isotope probes. And the corona discharge current might be translated into the electric potential gradient by calibration.

The simultaneous measurements of corona discharge current and electric charge on precipitation using a single transmitter system were carried out successively, even under strong wind conditions which are usual in winter thunderstorms of Japan. The design and method of this system are described below.

2. Preliminary test flights

In order to measure the air-earth conduction current in the troposphere and lower stratosphere, the radiosonde method were investigated by Kasemir and Ruhnke (1958) and Kasemir (1960). The same method was improved by Uchikawa (1963) and accepted for use in the special observation by Japan Meteorological Observatory. They developed "atmospheric electricity sonde" type RSII-E70, which was described in detail by Uchikawa (1966). As this sonde was completely developed for routine work, it was selected to measure corona discharge current with some alternations.

The main parts of the alternations are to lower the resistance of input shunt from 5×10^9 to 5×10^8 , 1×10^7 and $1 \times 10^6 \Omega$ and to shorten the length of antenna wire from 15 to 5 m. Therefore, the electric collection efficiency of the antenna may be lowered to 1/9 according to the theory of Chapman (1958) and Jhavar and Chalmers (1965).

The preliminary test flights were carried out on the campus of Hokkaido University in Jan. and Feb. 1974. Obtained results are shown in Fig.1. The left part of each figures show the vertical distribution of corona discharge current, and the right part show relative humidity observed by the upper air observation at Sapporo Meteorological Observatory. It is noted that the changes of corona discharge current were seen almost inside the cloud depth.

In the case of a single resistance of fixed value, the input voltage was too large for the measuring span or too small to be detected, because of the wide

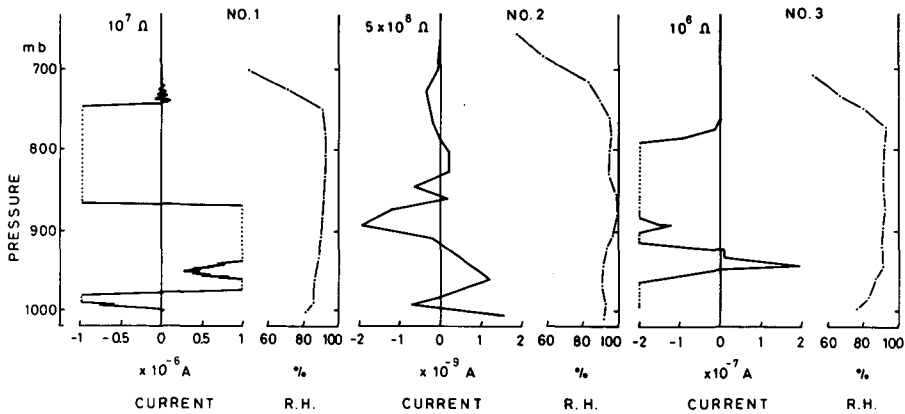

Fig. 1 Results of the preliminary test flights, which measured corona discharge current using a fixed value of resistance of input shunt.

variation of values of corona discharge current within cloud. In order to measure the corona discharge current completely, it seems to be necessary that the input shunts be replaced successively by some automatic switching device.

3. Method

3.1 The design of radiosonde

The block diagram of the measuring system is illustrated in Fig. 2. The electric charge on precipitation is measured by a Faraday cage which is connected to the input of high impedance DC amplifier that consists of vacuum tube 5886. Corona discharge current from the antenna is also connected to it. They are alternatively picked up by input selector. Output voltage is converted to frequency change, and it is added to the carrier wave with a frequency of 1680 MHz.

Pre-amplifier of precipitation charge is made on a similar principle as Takahashi (1965), but the electric circuit and parts are compacted. To distinguish signals from noises, input shunt is set to have large value of resistance, $2 \times 10^{10} \Omega$, which makes a slow tail in pulse wave of signals.

Antenna current is measured by detecting the voltage of four kinds of input shunts successively.

The switching of precipitation charge/corona discharge current, and individual input shunt is controlled by an input selector, the detailed schematics of which are shown in Fig. 3. Each one cycle has a period of 24 sec. which is divided into 12 segments having 2 sec. of period. The time share for the

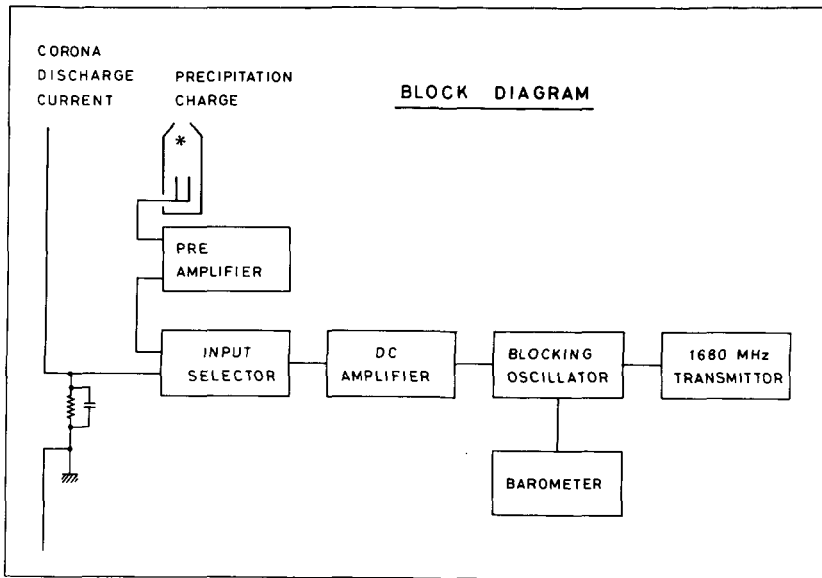

Fig. 2 Block diagram of the measuring system of specially designed sonde.

measurement of precipitation charge is 16 sec. and for the measurement of corona discharge current, the time share is 8 sec. During the measurement of corona discharge current, four couples of resistance and capacity are connected in turn.

It may be expected that since the electric field strength varies to the extent of 2 orders in clouds, corona discharge current may vary to the extent of 4 orders. Therefore, the values of four kinds of resistances were set from 5×10^4 to $5 \times 10^9 \Omega$ with multiples of about 50 each, as shown in the figure. On the other hand, the values of each capacity are selected so that the time constants fall in the range of 1 to 2.5 sec. It seems to satisfy the conditions of phase matching because the time constants of input shunts nearly agree to the time constant in thunderstorm that was deduced from the conductivity in thunderstorms by Freier (1963, 1967). And that is why the period of each segments for corona discharge current is set at 2 sec.

Although the input voltage of DC amplifier should range within $\pm 1V$, the vacuum tube 5886 is not disrupted even when a very high voltage was applied to input shunts.

The main part of this switching circuit is constructed by TTL IC. If we use C-MOS IC instead of TTL IC, the circuit may become more compact and may have a less power consumption. But, C-MOS IC is highly sensitive to static

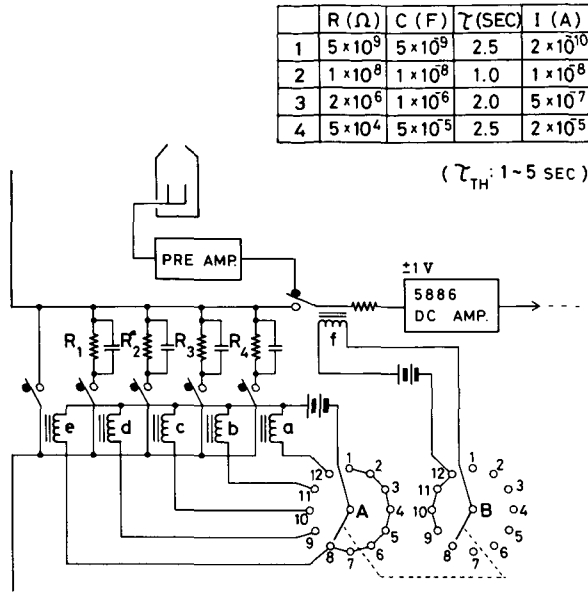

TIME SEQUENCE

STEP	1	2	3	4	5	6	7	8	9	10	11	12	SHUNT	CIRCUIT
RELAY	a												R ₁	A
	b												R ₂	
	c												R ₃	
	d												R ₄	
	e													
f													SELECTOR	B
MESUREMENT	ELECTRIC CHARGE ON PRECIPITATION								CORONA DISCHARGE CURRENT				2 sec a step 24 sec a cycle	

Fig. 3 Detailed schematics and time sequence of input selector. The combinations of values of resistances, capacities, time constants and measurement ranges are shown in the upper part.

discharge, which sometimes causes it break down. Thus, C-MOS IC was not used for measurement in thunderclouds. Even in the case of TTL IC, the power consumption is small enough for the observation through a thundercloud. The circuit can continue to work for 3 hours using four UM-5 dry batteries connected in series.

The appearance of the whole sonde system is illustrated in Fig. 4, which is modified from "atmospheric electricity sonde" type RSII-E70. The original Gerdien tube was replaced by a precipitation charge sonde, and the upper and lower antenna was shortened to 2 m respectively. Total length of the sonde is

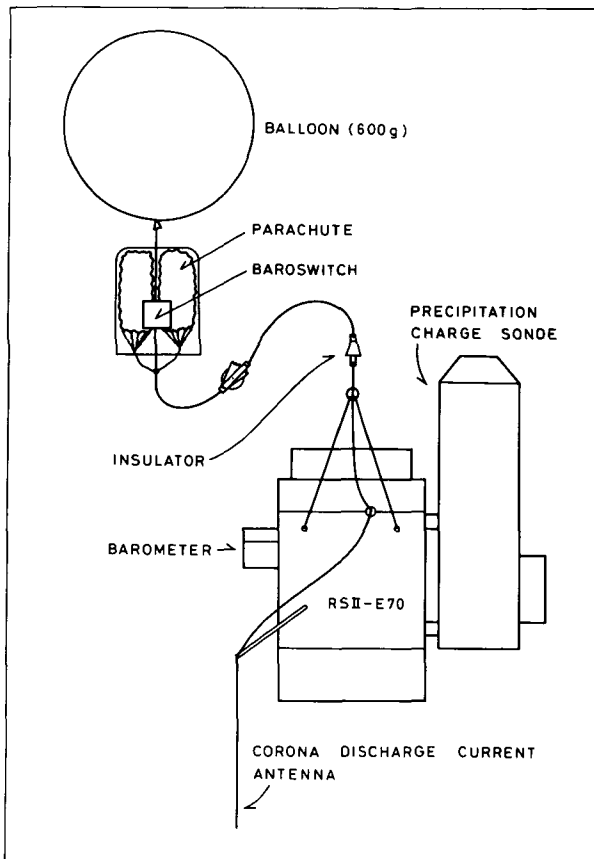

Fig. 4 Appearance of whole sonde system, not in scale.

4.5 m, although the upper antenna is wound in a reel before launching, and it is slowly released after launching. Between the balloon and the sonde, an automatic cutting device is connected which cuts the suspension thread when the sonde reached the presetted altitude of 500 mb. Then the sonde is separated and descends slowly suspended by two parachutes. On the surface of the sonde, a message and return address are printed for the discoverer of the sonde.

3.2 Calibration

The measuring system of electric charge on precipitation was calibrated by means of dropping water drops which had known quantities of electric charge into the Faraday cage of the sonde, and reading the records of receiving system.

The measuring system of corona discharge current was examined and

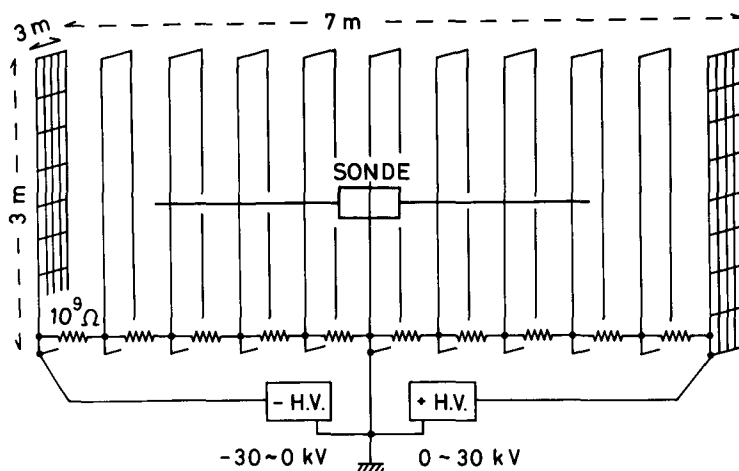

Fig. 5 Side view of the artificial electric field cage used for calibration.

calibrated in the artificial electric field as shown in Fig. 5. According to Kasemir's theory, the electric collection area was calculated to be 8 m^2 for an antenna of 4.5 m long. Therefore, the size of the artificial electric field cage was designed as $3 \text{ m} \times 3 \text{ m} \times 7 \text{ m}$. The sonde and the antenna were suspended horizontally, and eleven square loops of fine wire surrounded them vertically. Loops on both ends were made as a net having $30 \text{ cm} \times 30 \text{ cm}$ mesh, and were connected to two sets of high voltage suppliers which can supply the symmetric voltage of opposite sign up to $\pm 30 \text{ kV}$ respectively. Ten pieces of resistance of $10^9 \Omega$ were inserted between each adjacent loops, and the central loop was connected to the ground. Therefore, the electric potential differences between each adjacent loops were held equal, and the electric field strength could be applied up to 8.6 kV/m . The record of the receiver were calibrated against the applied field strength, as curves shown in Fig. 6.

In clouds, the sonde may be exposed to more strong electric fields, but calibrations could not be extended beyond such a high value because of the limit of high voltage supplier. However, Chapman (1958) reported that under such strong electric fields, corona discharge current may be proportional to the constant power of electric field, steadily. Therefore, it seems reliable to extrapolate the calibration curve with a slope of about 2.5th power.

3.3 Procedures of launching

The observations were carried out at Unoke town, Ishikawa prefecture, in the northwest coast of Japan Islands, in Dec. 1978.

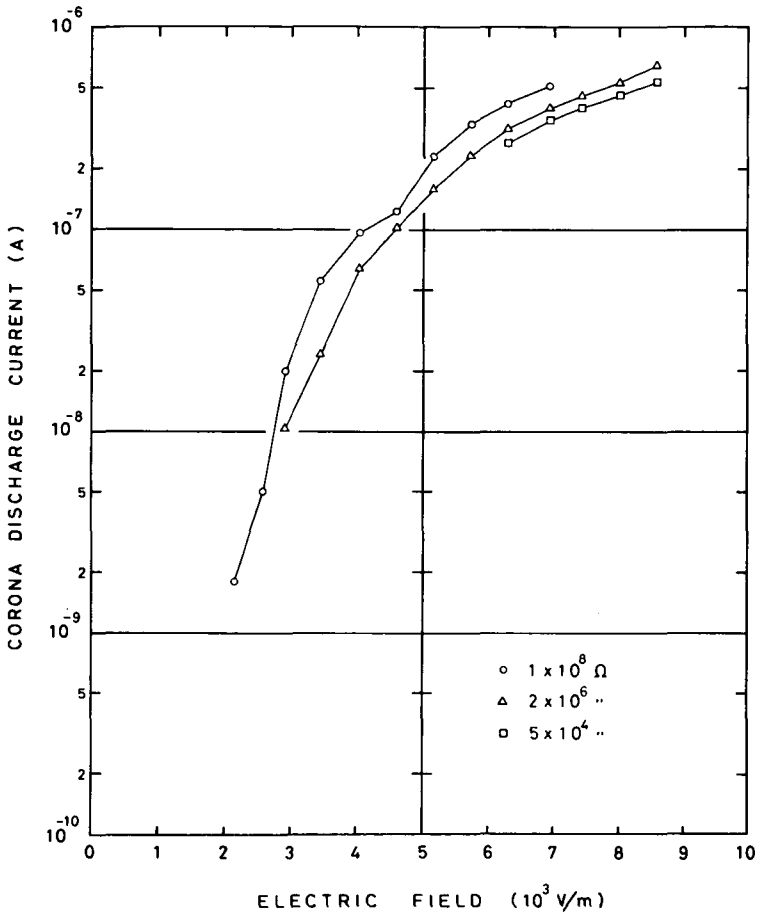

Fig. 6 Calibration curves of corona discharge current against applied electric field, for three kinds of values of resistance of input shunt.

The launching time was decided by the aid of a radar. When it was forecasted that a thundercloud would pass over the observation site, a balloon was filled with helium gas, then, all of the accessories of a sonde were connected to the balloon. The device was held by two persons. And it was launched after waiting until both the electric field and the precipitation charge built up to considerable high values, furthermore, when strong wind gusts were not present.

The received signals were recorded by both pen recorder and a magnetic tape recorder in order to distinguish the signals from the noises afterwards.

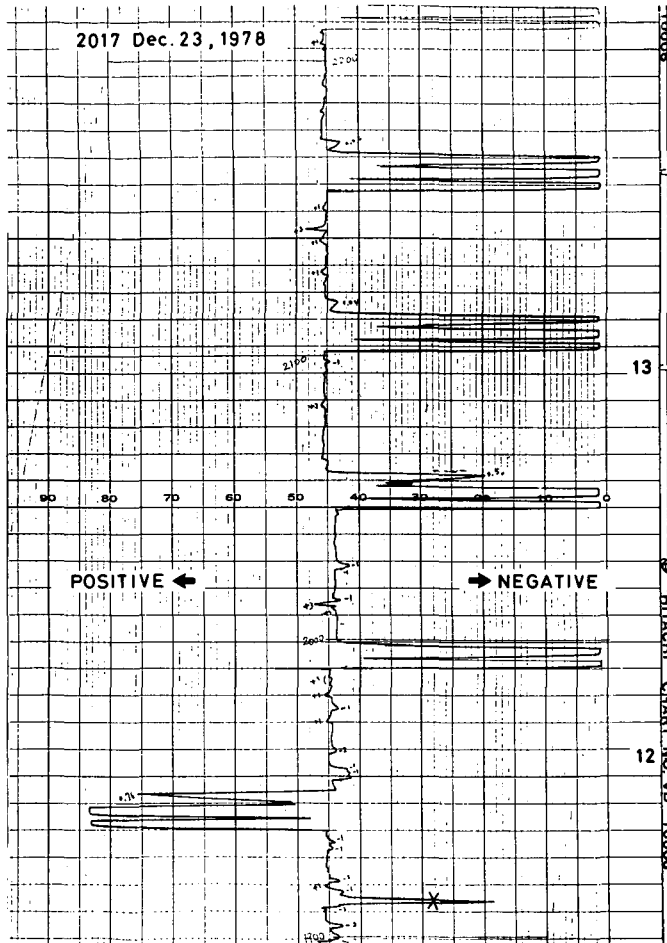

Fig. 7 An example of recording chart on Dec. 23, 1978.

4. Results

Although we did not have thunderstorms frequently in the observation period, several records were obtained, which are shown in Figs. 7 and 8.

Fig. 7 shows a part of the recording chart of a case in point. The figures of 12 and 13 on the right end of the chart are the time elapsed after launching in minutes. The center of the chart is zero, and the right and the left side of the chart correspond to negative and positive sign of values of the corona discharge current and electric charge on precipitation, respectively.

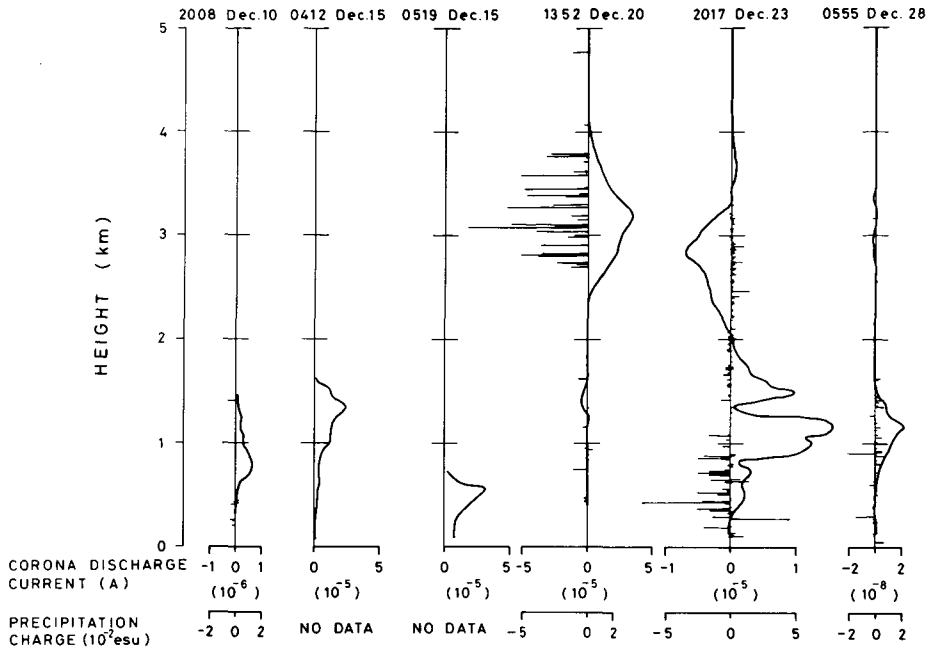

Fig. 8 Vertical distributions of electric potential gradient (solid curves) and electric charge on precipitation particles (horizontal bars).

It is seen that the sign of corona discharge current changed from positive to negative at about 12 min. after launching, and then, the value of current increased from 3rd to 4th input shunt range. During the time for measuring electric charge on precipitation (16 sec.), several small spikes are seen on both sides of the chart, and the lengths thereof show the values of individual electric charges on precipitation particles.

Six observations were made during the observation period. The distributions of vertical electric potential gradient and the electric charge on precipitation are shown in Fig. 8.

In the earlier three cases, the precipitation charge was not measured due to a mechanical trouble in one of the relays. After some alternations, successful measurements were performed in the later three cases.

It is useful to know the relationship between the magnitude of corona discharge current in the cloud and the strength of the surface electric field, in order to forecast the value of corona discharge current in the cloud and adjust the sensitivity of the sonde before launching. It is shown in Table 1 that the several relations between the peak values of corona discharge current in the

Table 1. Relationships between the magnitude of corona discharge current in cloud and the strength of the surface electric field.

Maximum intensity of surface electric field	Maximum value of corona discharge current in cloud
800(V/m)	2×10^{-9} (A)
2000	2×10^{-8}
5000	1×10^{-7}
7000	1×10^{-5}
8000	3×10^{-5}
10000	6×10^{-5}

cloud and electric field at the surface, obtained up to date.

5. Consideration

It may be considered that the corona discharge current method to measure the electric field without any mechanical parts, is more convenient than field mill method for the measurement under the condition of strong winds. But the calibration of corona discharge current against the electric field strength seems to be complicated and leaves some problems. The most important problem is that whether the calibration at the surface is applicable in clouds or not, because the conductivity and pressure are different.

The detectable values of corona discharge current of this sonde lie within the range of 2×10^{-10} to 2×10^{-5} A. But, since the values less than 10^{-8} A were erratic and not reproduceable, they should be neglected.

In the case of 25 Dec. 1978, a lightning flash was observed by a group from Nagoya University that were engaged in measuring the electric field changes by means of slow and fast antennas. In the same storm, but at different time, the sonde measured 1.6×10^{-5} A in corona discharge current which was the maximum value in this observation.

Therefore it may be considered that the measurement ranges are sufficiently suitable to measure the variation of corona discharge current which occur in winter thunderstorms of this region.

It seems that time intervals of 16 sec. and 8 sec. for measurement of electric charge on precipitation and corona discharge current was satisfactory. As a matter of fact, the total measuring points for corona discharge current are expected to be sixty to seventy for one flight through the cloud depth of about

4 km. And 2/3 of the whole measurement period is dealt for the precipitation charge measurement. These are considered to be sufficient to investigate the whole picture of electrical structure of the thunderstorms.

There was a trouble in a relay which is shown as "relay f" in Fig. 3. It may be considered that after several openings and closings, the relay may have been damaged by sparks between contact points caused by strong electric field in thunderclouds, and fusion and welding might occur on contact pieces, then the contact pieces failed to return to the normal position. In fact, after the replacement of relay f with another type which had different contact pieces and stronger return force, no trouble occurred in the switching action.

6. Conclusion

In winter thunderstorms in Japan, the surface wind is generally too strong to launch a sonde which have some mechanical parts such as field mills.

For sonde observations, it is convenient to measure a corona discharge current which can be translated into electric potential gradient using some calibrations, because the sonde does not need any moving parts.

To measure the wide variation of corona discharge current it is necessary for the sonde to have an automatic input selector which can change to four kinds of sensitivities.

A specially designed sonde can measure corona discharge current of 2×10^{-10} to 2×10^{-5} A and electric charge on precipitation particles of 10^{-3} e.s.u. to 10^{-1} e.s.u., simultaneously.

When a lightning flash was observed, the sonde measured the maximum value of 1.6×10^{-5} A in corona discharge current. Therefore, the sonde seems to have sufficient coverage for variation in thunderstorms.

When the aid of a radar is applicable, this sonde may become a more effective tool for thundercloud investigation. It may provide us with numerous data i.e. the distribution of corona discharge current which may be translated into vertical field strength, then to total space charge, electric charge on precipitation particles, air motion, position and flight path of sonde in the cloud, and the picture of precipitation echo around the path.

In order to investigate the roles of precipitation element in thunderstorm electrification, it is expected that this sonde may be one of the most effective tools in balloon observations.

Acknowledgements

The authors wish to thank Dr. K. Uchikawa, Japan Meteorological Agency, who allowed us to modify the system of "atmospheric electricity sonde", and also Dr. I. Wakisaka, Director of Sand Dune Agricultural Experimental Station at Unoke, Ishikawa Prefecture, who provided us with the place for observation site and many facilities.

References

- Belin, R.E., 1948. A radiosonde method for atmospheric potential gradient measurements. *Proc. Phys. Soc.*, **60**, 381-387.
- Chapman, S., 1958. Corona-point-discharge in wind and application to thunderclouds. *Recent Advances in Atmospheric Electricity*, Pergamon Press, Oxford, 277-288.
- Freier, G.D., 1963. A theoretical study of conductivity of air in thunderstorm. *J. Geophys. Res.*, **68**, 4941-4947.
- Freier, G.D., 1967. The relaxation time of air in thunderstorm. *Mon. Wea. Rev.*, **95**, 843-846.
- Jhawar, D.S. and J.A. Chalmers, 1965. Point discharge from multiple point. *J. Atmos. Terr. Phys.*, **27**, 367-371.
- Kasemir, H.W., 1960. A radiosonde for measuring the air-earth current density. USAS-RDL-Technical Report, 2125.
- Kasemir, H.W. and L.H. Ruhnke, 1958. Antenna problem of measurement of the air-earth current. *Recent Advances in Atmospheric Electricity*, Pergamon Press, Oxford, 137-147.
- Simpson, G.C. and F.J. Scrase, 1937. The distribution of electricity in thunderclouds. *Proc. Roy. Soc.*, **A**, **161**, 309-352.
- Takahashi, T., 1965. Measurement of electric charge in thundercloud by means of radiosonde. *J. Meteor. Soc. Japan*, **43**, 206-217.
- Takahashi, T., 1978. Electrical properties of oceanic tropical clouds at Ponape, Micronesia. *Mon. Wea. Rev.*, **106**, 1598-1612.
- Uchikawa, K., 1963. On the improvement of the atmospheric electricity radiosonde. *Geophys. Mag.*, **31**, 705-714.
- Uchikawa, K., 1966. Atmospheric electricity radiosondes for the IQSY. *Geophys. Mag.*, **33**, 163-177.
- Winn, W.P., C.B. Moore, C.R. Holmes and L.G. Byerly III, 1978. Thunderstorm on July 16, 1975, over Langmuir laboratory: A case study. *J. Geophys. Res.*, **83**, 3079-3092.