



HOKKAIDO UNIVERSITY

Title	The Effect of Nucleation on the Morphology of Snow Crystals in Low Temperature Conditions
Author(s)	SATO, Noboru; KIKUCHI, Katsuhiro
Citation	Journal of the Faculty of Science, Hokkaido University. Series 7, Geophysics, 8(3), 259-280
Issue Date	1988-02-29
Doc URL	https://hdl.handle.net/2115/8764
Type	departmental bulletin paper
File Information	8(3)_p259-280.pdf



The Effect of Nucleation on the Morphology of Snow Crystals in Low Temperature Conditions

Noboru Sato* and Katsuhiko Kikuchi

*Department of Geophysics, Faculty of Science,
Hokkaido University, Sapporo 060, Japan*

(Received Nov. 27, 1987)

Abstract

Experiments of formation and growth of ice crystals were carried out in situ observation to examine the effect of ice nuclei and nucleation process on formation of the peculiar shaped ice crystals in low temperature conditions below -20°C . The main results obtained in these experiments were as follows. 1) Some substances of rock-forming minerals and clay minerals had a tendency to become ice nuclei of peculiar shaped ice crystals readily. 2) The temperature at which peculiar shaped ice crystals produced with ease depended on the substance of ice nuclei. 3) A relationship between the type of peculiar shaped ice crystals and the substances of ice nuclei, temperature and the manner of nucleation is not clear. 4) The larger the substance of ice nuclei was, the more the polycrystalline ice crystals were and peculiar shaped ice crystals were produced. 5) The production ratio of peculiar shaped ice crystals at the initial nucleation was higher than that at preactivation. 6) The production ratio of peculiar shaped ice crystals which grew from frozen water droplets was about 35% at -35°C .

These experimental results showed that the water saturation was sufficient condition for the making of peculiar shaped ice crystals, that is, the nucleation mode was condensation-freezing on ice nuclei and freezing of cloud droplet. The temperature at which the production ratio of peculiar shaped ice crystals decreased might correspond to a temperature at which the nucleation mode changed from condensation-freezing mode to deposition mode. These speculations from experimental results seem to be consistent with the observation results of center nuclei of snow crystals in nature.

1. Introduction

In order to clarify the variety in growth forms of snow crystals, numerous experiments of artificial snow crystals have been carried out to study the relation between growth forms of single snow crystals and growth conditions

* Present affiliation: Science Education Institute of Osaka Prefecture, Sumiyoshi-ku, Osaka 558, Japan.

(Nakaya (1954), Hallett and Mason (1958), Kobayashi (1957, 1961)). The variation of growth forms shows two features: three changes in habit (plate or column) with temperature, and morphological instability with supersaturation related to dendrites, hollow prisms and so on.

These studies were carried out mainly for single snow crystals although snow polycrystals (snow crystal of polycrystalline type) have been frequently observed. During the last fifteen years progress has been made in understanding structure and formation mechanism of snow polycrystals (Lee, 1972; Uyeda and Kikuchi, 1976; Kobayashi et al., 1976, a, b).

Kikuchi (1970) observed snow crystals of non-hexagonal shape in Antarctica which had not been reported till that time, and Kikuchi termed them "peculiar shaped crystals" including polycrystalline types. For example, the gohei twins, seagull type and extended prism planes. The characters of these crystals are that the prism planes of snow crystals grow abnormally. And these were considered to grow below -25°C . Sato and Kikuchi (1983) succeeded in making various types of peculiar snow crystals artificially which were already observed under natural conditions in the polar regions. The production ratio of these crystals to the basic and regular shapes of snow crystals was 3.4% on the average (Kikuchi and Sato, 1984), which seems to be equal to the frequency of peculiar shapes in nature (Kajikawa et al., 1980).

On the other hand, there is certain evidence that in some cases the external forms of ice and snow crystals are influenced by the way in which they are nucleated. Schaefer and Cheng (1968) found that when different ice nuclei were used to nucleate ice crystals in a supercooled cloud at -20°C , the ice crystals which developed had different surface features and in some cases different shapes like arrowheads. Yamashita (1971, 1973) reported that trigonal ice crystals were found when the air was cooled either by adiabatic expansion or by a very cold object in his large cold chamber, and trapezoidal and V-shaped ice crystals were also produced when the air was cooled by a very cold object. Recently, Takahashi (1983) carried out an investigation on the effect of ice nuclei, their size and their crystalline structure on the shape of ice crystals using a large cold chamber. He concluded that ice crystals grown from the ice nuclei larger than $10\ \mu\text{m}$ of polycrystalline type were polycrystalline type.

The present experiment was carried out to examine the effect of ice nuclei and nucleation process on the formation of the peculiar shaped snow crystals. The experiment was carried out using in situ observation of ice crystals to observe how the ice nucleus corresponded to the ice crystal.

2. Experiment

2.1 Experimental method

An outline of a thermal diffusion cold chamber used in this experiment is given in Fig. 1. The cold chamber is mounted on a stage of an inverted microscope. The diameters of the upper and lower stages in the chamber are 40 mm and they were separated by 6 mm. Liquid nitrogen held in a jar is forced onto the stages in the chamber by nitrogen gas pressure. By controlling the flow rate of the liquid nitrogen and using a heater imbedded in the lower stage, the temperatures of the stages are maintained independently at any desired value down to -70°C and their cooling rates could also be controlled. Temperatures of the upper and lower stages (T_t and T_b) are measured with fine thermocouples attached directly to the surfaces. The surface of both stages is lined with ice sheets formed by freezing distilled and deionized water. The ice sheets are the source of water vapor by which snow crystal growth induced. At the center of both stages, there is a window of 8 mm in diameter through which the growing snow crystals are observed with transmitted light. The observation window is exposed to heated nitrogen gas in order to prevent window frost.

Five kinds of rock-forming minerals (microcline, quartz, augite, calcite and biotite), two kinds of clay minerals (kaolinite and montmorillonite) and silver iodide (AgI) were examined as the ice nuclei. Substances prepared in this experiment are summarized in Table 1 with crystalline structure and lattice parameters. Fine particles of rock-forming minerals were prepared by crush-

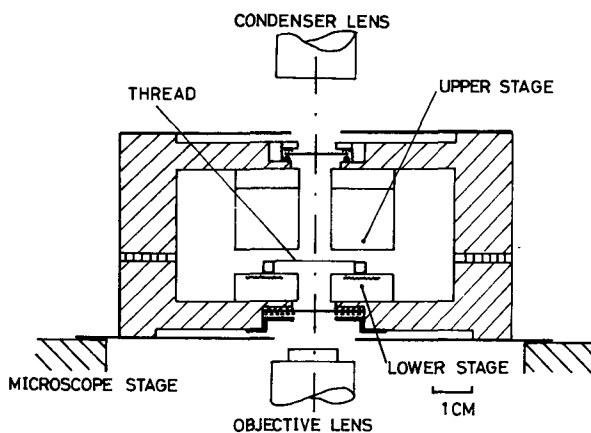

Fig. 1 Schematic diagram of the thermal diffusion type cold chamber.

Table 1 Crystallographic parameters of the substance of ice nuclei used in this experiment.

Substance	Crystal structure	Lattice parameters (Å)		
		a	b	c
Microcline	Triclinic	8.578	12.960	7.211
Quartz	Hexagonal	4.913	4.913	5.405
Augite	Monoclinic	9.79	8.96	5.25
Calcite	Hexagonal	4.99	4.99	17.06
Biotite	Monoclinic	5.31	9.23	20.36
Montmorillonite	Monoclinic	5.17	8.94	9.95
Kaolinite	Triclinic	5.15	8.95	7.39
AgI	Hexagonal	4.58	4.58	7.49
Ice	Hexagonal	4.523	4.523	7.367

ing the minerals in an iron mortar and grinding them finely in an agate mortar. The particles were adhered on two fine threads of $3.2 \mu\text{m}$ in diameter which were stretched to about 2 mm apart on a plastic frame.

Before starting an experiment, a plastic frame is placed in the center of the chamber. The temperature near the thread, T_a , was measured with a fine thermocouple. The temperature difference between the upper and lower ice sheets, ΔT , was controlled in such a way that snow crystals nucleated on the threads. If ΔT was too large, the threads were usually covered all over with hoar frost. Isolated crystals are formed on the threads when ΔT is optimal. After the appearance of crystals on the threads, T_t and T_b are fixed in a constant condition and a steady state condition is immediately achieved. The snow crystals are grown on the threads under constant temperature conditions.

The experiment of freezing of water droplets was carried out as follows. The temperature condition was held at constant and after that the water droplets which were made by a humidifier were introduced in the chamber through the observation window. Their mode size was $12 \mu\text{m}$ in diameter. Some of them were adhered to a fine thread of $3.2 \mu\text{m}$ in diameter. After that they froze and grew to ice crystals on the thread.

2.2 Formation conditions of artificial snow crystals

The vertical temperature profile in the cold chamber was measured at intervals of one millimeter with a very fine thermocouple. The measured temperature profiles were almost linear.

From the observation of the state of thread, it was found that the artificial ice crystals passed through a liquid phase at the nucleation stage at higher temperature. It was concluded therefore that the water vapor pressure was at or near water saturation. This probability decreased as the crystal grew because many crystals grew on a thread and each crystal competed with the others for the water vapor.

In order to estimate the saturation with respect to ice surface, linear growth rates of the columnar crystals were measured. The linear growth rates were converted to mass growth rates using $m=1.3a^2l$, where m is the mass in milligrams, a , the radius, and l , the length of the column in millimeter (Higuchi, 1956). The rate of increase of the crystal mass, m is $dm/dt=4\pi CD(\rho_\infty-\rho_0)$, where C is the electrostatic capacity of the crystal, D the diffusion coefficient of water vapor in air, ρ_0 the vapor density at the surface of the growing crystal and

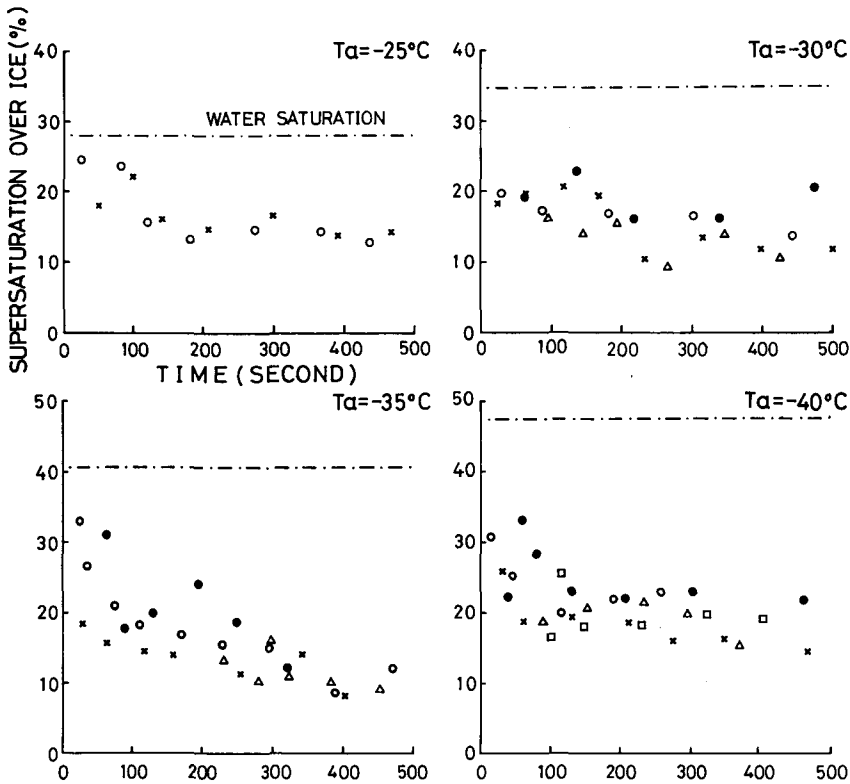

Fig.2 Supersaturation in cold chamber as a function of time when T_a was -25° , -30° , -35° and -40°C .

ρ_{∞} is the value at a great distance from the ice crystal in the undisturbed field (Houghton, 1950). This equation does not take into account the influence of interface kinetics and considers only the influence of the water vapor field.

The vapor pressure can be estimated using this equation. Examples at $T_a = -25^{\circ}$, -30° , -35° , and -40°C are shown in Fig. 2. The ordinate and abscissa show supersaturation with respect to ice and the lapse of time from the nucleation of the ice crystals, respectively. The same symbol in this figure shows the same column growing as time progressed. This figure shows how the supersaturation decreased with time: it was reduced by half after about 10 minutes elapsed from the nucleation of crystals. If the influence of the interface kinetics is taken into account, the supersaturation will be increased (Beckmann, 1982). The supersaturation obviously depends also on the crystal spacing along the threads.

3. Results

3.1 Ice nucleation by particles (Heterogeneous nucleation)

Experiments were made to clarify the following four effects: a) Substance of nuclei, b) Temperature, c) Preactivation and d) Size of nuclei. Experimental results will be described in this order.

a. Effect of substance of nuclei

Ice nuclei of various substances were tested at temperature about -30°C . Size distributions used in this experiment are shown in Fig. 3. Microcline shows wider distribution. Other substances of nuclei show narrow distributions smaller than $30\ \mu\text{m}$ in diameter. Open circles connected with dotted lines show size distributions of particles which were prepared in this experiment and solid circles with solid lines show size distributions of particles on which ice crystals nucleated and grew. These size distributions are larger than those of ice nuclei in nature.

Nucleation ratio of each particle is shown in Fig. 4. The numbers of examined particles (N_0) are shown at the right hand side in the figure and those were over 50 particles. The nucleation ratios of microcline, quartz and AgI were high and other particles were less than 50%. Especially, biotite was not nucleated easily. The clay minerals (kaolinite and montmorillonite) known as good ice nuclei in nature did not show a high nucleation ratio.

Ice crystals growing on the ice nuclei were classified into five types: column, combination of columns, combination of columns and plates, radiating assemblage of plates and peculiar shaped crystals. Typical growing ice crys-

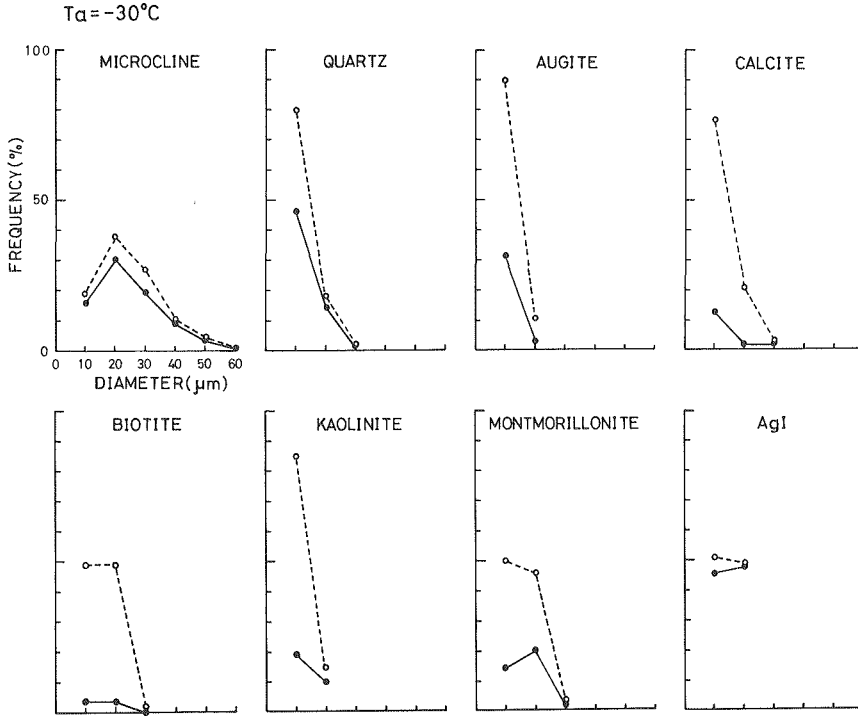

Fig. 3 Size distribution of particles of each substance.

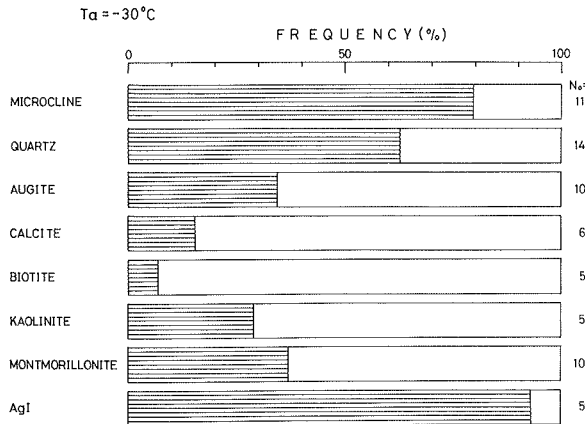

Fig. 4 Nucleation ratio on each substance of ice nuclei.

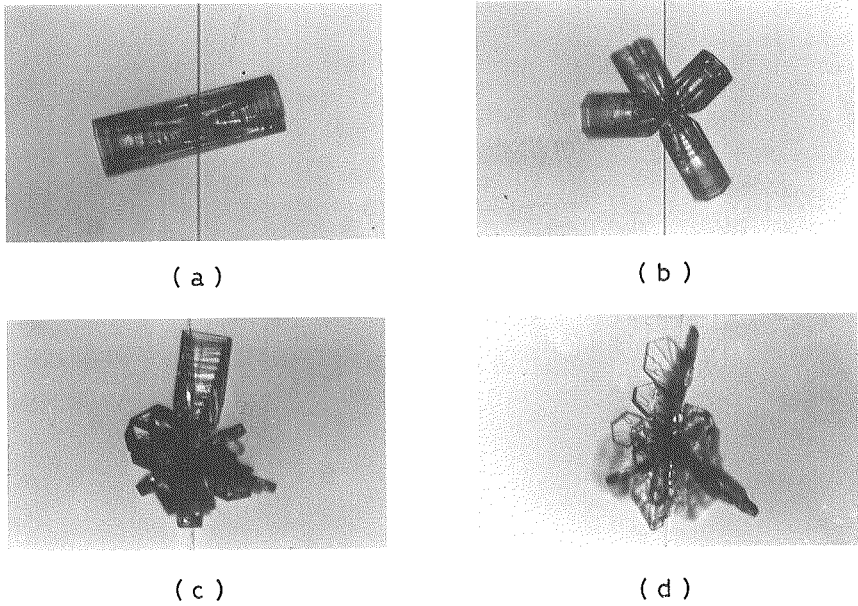

Fig.5 Examples of each type of ice crystals. (a) column, (b) combination of columns, (c) combination of columns and plates and (d) radiating assemblage of plates.

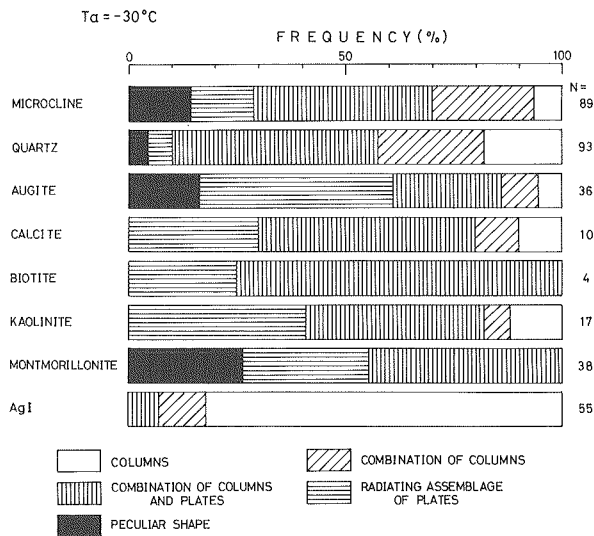

Fig.6 Production ratio of ice crystal shape at -30°C .

tals of each type except peculiar shapes are shown in Fig. 5. Figure 6 shows the production ratio of ice crystals. The number (N) of ice crystals made in this experiment is shown at the right hand side of Fig. 6, respectively. In the case of AgI particles, the production ratio of single crystals (columns) exceeded 80%. Polycrystalline ice crystals grew frequently except for AgI and their production ratios exceeded 80%. Peculiar shaped crystals were not formed on the particles of calcite, biotite and kaolinite which showed a low nucleation ratio. The production ratio of peculiar shaped crystals on the montmorillonite was about

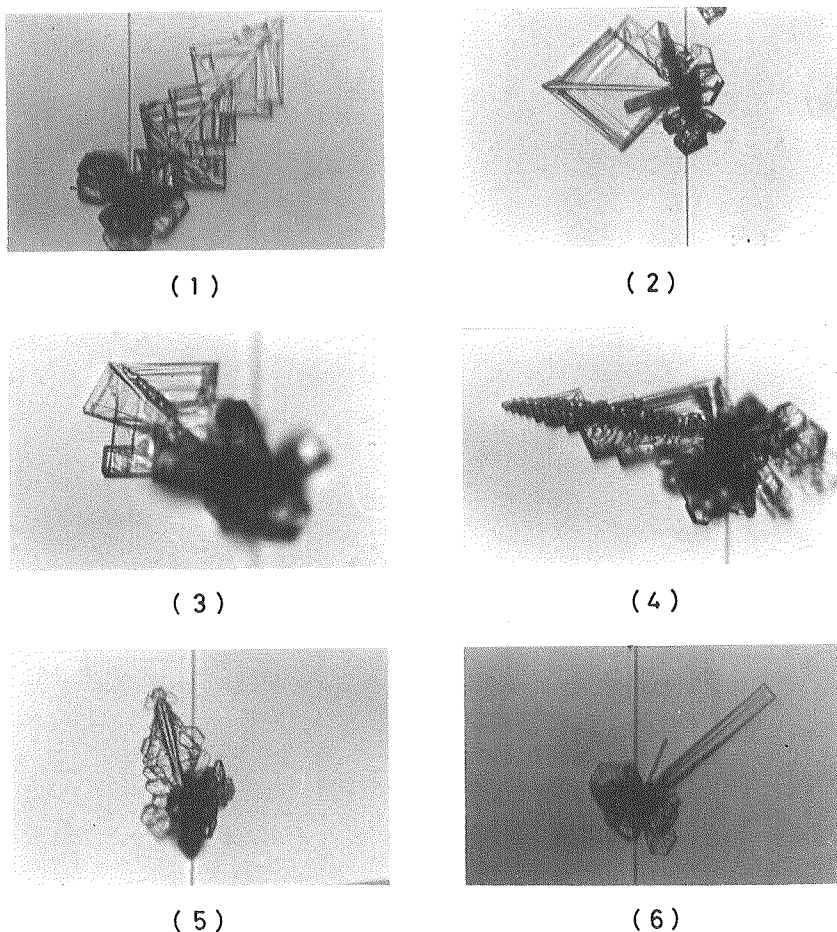
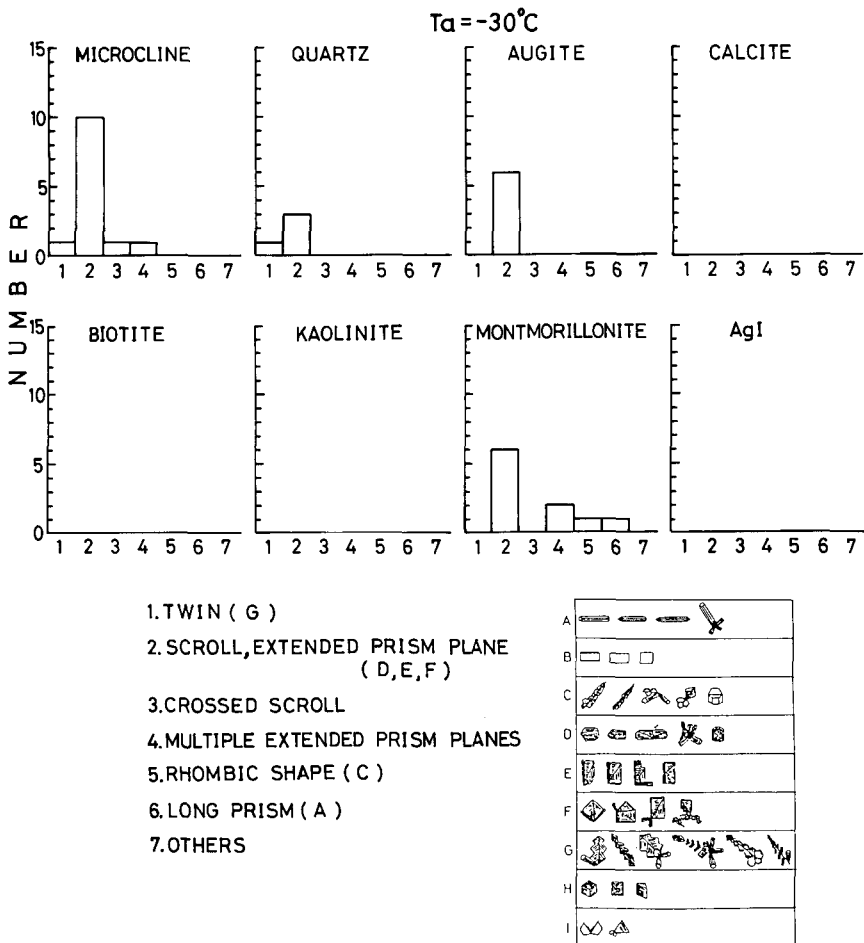

Fig. 7 Examples of peculiar shapes. (1) twin, (2) scroll and extended prism plane, (3) crossed scroll, (4) multiple extended prism planes, (5) rhombic shape and (6) long prism.

25%, at maximum in this experiment and those on the augite and the microcline were about 15%. The production ratio on the quartz was about 5%.

Peculiar crystals were classified into seven groups on the basis of classification by Kajikawa et al. (1980). "Twin" type (group 1) corresponds to the group G in Kajikawa et al. (1980). Similarly, "Scroll" and "Extended prism planes" (group 2) correspond to groups D, E and F, "Rhombic shape" (group 5) to group C and "Long prism" (group 6) to group A, respectively. "Crossed scroll" (group 3) is classified newly. In this crystal, two scroll planes appear to



KAJIKAWA et al. (1980)

Fig. 8 Number frequency of peculiar shaped ice crystals.

cross each other. "Multiple extended prism planes" (group 4) is a linear assemblage of incomplete columns. The others were classified as "Unknown" (group 7). Typical ice crystals of each group are shown in Fig. 7. However, it is understood that the "Twin" is a special case of the "Extended" prism planes".

Number frequencies of peculiar shaped crystals are shown in Fig. 8. Scroll and extended prism planes (group 2) were predominant in all substances of ice nuclei. The relationship between the type of peculiar shapes and the substance of ice nuclei was not clear in this result.

b. Effect of temperature

In order to investigate the effect of temperature on relationship between ice crystal shapes and ice nuclei, the experiments were made at temperatures between -20° and -40°C at intervals of 5 degrees. The microcline particles were used as the substance of ice nuclei in this experiment, which is the common rock-forming mineral in nature. The size distribution at -30°C was rather wide but other size distributions were smaller than $30\ \mu\text{m}$ in diameter as shown in Fig. 3. Figure 9 shows the nucleation ratio at each temperature. The number (N_0) at the right hand side of Fig. 9 shows the total number of particles of microcline used in this experiment. The number of nuclei was over 50 particles. The nucleation ratio of microcline did not necessarily increase, with the decreasing air temperature. The nucleation ratio, however, increased suddenly at -25°C . In the temperature range below -30°C , the nucleation ratios were about 70%. The substance of microcline at -20°C was not easily nucleated.

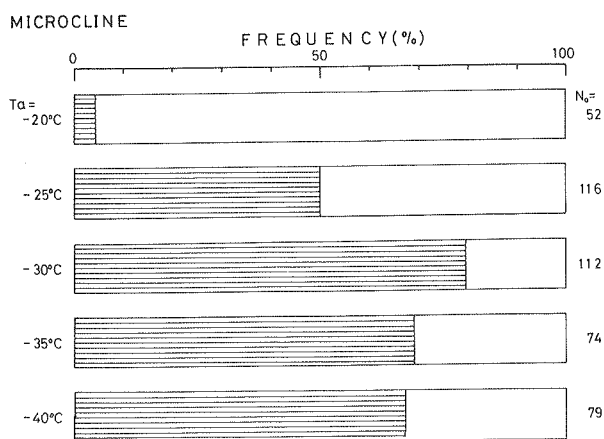

Fig. 9 Nucleation ratio at each temperature on microcline.

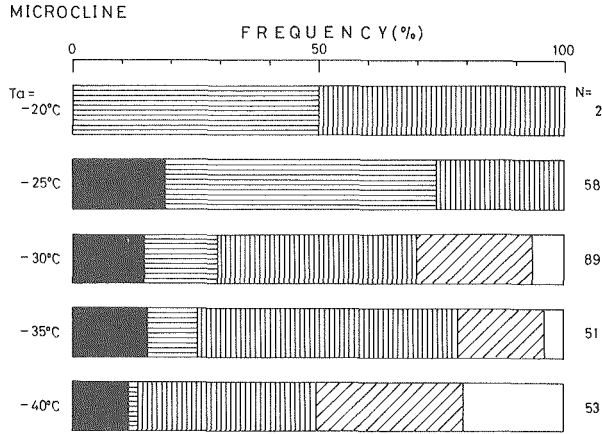

Fig. 10 Production ratio of ice crystals at each temperature on microcline.

Figure 10 shows the production ratios of each ice crystal shape, which are the percentages of each ice crystal shape to the total number of ice crystals at each temperature of the microcline. The numbers (N) at the right hand side of Fig. 10 show the total numbers of ice crystals formed at each air temperature (T_a).

Combination of columns shown by slanted stripes, most of which correspond to a combination of bullets, was not grown above -25°C , but they grew below -30°C . The predominant shape of ice crystals above -25°C was radiating assemblage of plates shown by horizontal stripes, and that below -30°C was

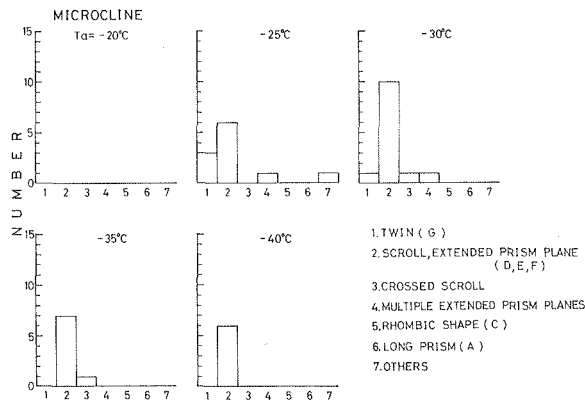

Fig. 11 Number frequency of peculiar crystals.

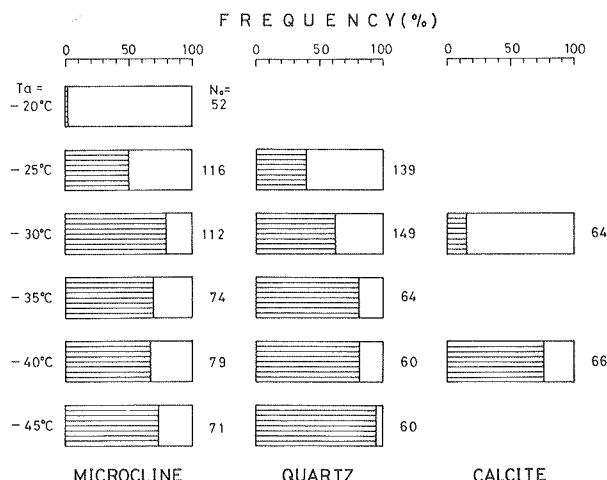

Fig. 12 Change of nucleation ratio with temperature on microcline, quartz and calcite.

combination of columns and plates shown by vertical stripes. The percentage of peculiar shaped crystal was about 15% below -25°C . Number frequencies of peculiar shaped crystals are shown in Fig. 11 by each group. Most of the peculiar shaped crystals were scroll and extended prism planes (group 2). At -25°C , twin (group 1) was made at higher percentage than at other temperatures. However, the relationship between temperature and group of peculiar shaped crystals was not clear.

Moreover quartz and calcite particles were examined at temperature ranges from -20° to -45°C . The results of them are shown in Figs. 12 and 13 together with the results of microcline particles. In the nucleation ratio shown in Fig. 12, the systematic increase of nucleation ratio with temperature decrease was shown in the case of quartz. The prevailing type of ice crystals was radiating assemblage of plates shown by horizontal stripes at -25°C , combination of columns and plates shown by vertical stripes at -30° and -35°C , and combination of columns shown by slanted stripes at -40° and -45°C . Production ratio of peculiar shapes of microcline was larger than those of quartz and calcite at all temperatures shown in Fig. 13. It appears that there is a suitable temperature for each substance of ice nuclei at which the peculiar shaped crystals are produced most readily.

c. *Effect of preactivation*

The effect of the nucleation on the production ratio of peculiar shapes was

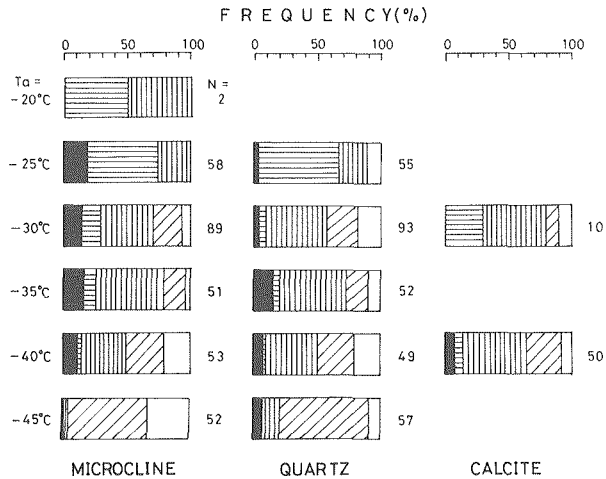

Fig. 13 Change of production ratio of various types of ice crystals with temperature.

investigated. In this experiment, ice crystals were nucleated on the ice nuclei (initial nucleation) and grew, after which ice crystals were sublimated. Then, ice crystals were again nucleated on the same ice nuclei (preactivation). The mineral particles were found to exhibit a considerably improved nucleability at preactivation (Roberts and Hallett, 1968). The difference of production ratio of peculiar shapes between initial nucleation and preactivation was examined. In this experiment, microcline particles were used as the ice nuclei.

The experimental process of air temperature (T_a) is shown in Fig. 14. The temperature (T_a) was decreased from room temperature to -30°C in 30 minutes. Ice crystals were nucleated on the particles of microcline. They

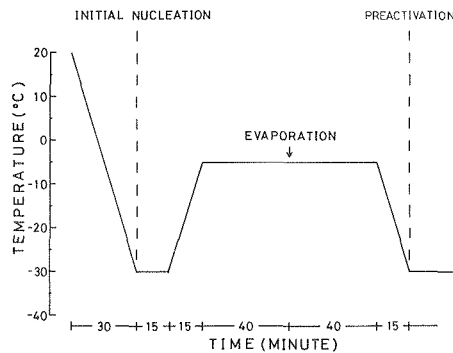

Fig. 14 Temperature history in the cold chamber at preactivation.

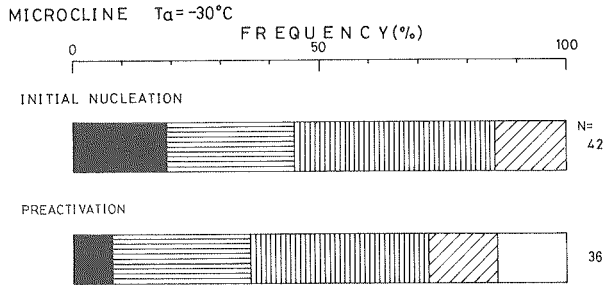

Fig. 15 Production ratio of various types of ice crystals at initial nucleation and preactivation.

grew during 15 minutes to grow to about $250\ \mu\text{m}$ in diameter. Then, the air temperature (T_a) was increased to -5°C and the temperature difference ΔT became zero during the following 15 minutes. After the following 40 minutes, this condition, that is, $T_a = -5^\circ\text{C}$ and $\Delta T = 0$, was conserved. Thus, all ice crystals on the threads were evaporated on the level of naked eye. Moreover, this condition continued for 40 minutes. Then, T_a decreased and ΔT increased again. Therefore, the preactivation of the ice crystal was examined.

Figure 15 shows the experimental results for the microcline particles. Compared with the initial nucleation and preactivation, two remarkable features were found. One was that the single crystals were produced abundantly in the preactivation than in the initial nucleation. Another was that peculiar crystals were produced abundantly in the initial nucleation than in the preactivation. The activation site in the preactivation which was thought to be a tiny ice surface (Roberts and Hallett, 1968) was activated more strongly in the preactivation in lower supersaturation than in the initial nucleation. Thus, it was considered that the single crystals were grown abundantly in the preactivation than in the initial nucleation.

d. Effect of size

In order to investigate the effect of size of ice nuclei, microcline particles were used as ice nuclei. The experiment was carried out by dividing the larger size group (L) and smaller size group (S). The temperature condition was uniformly at -30°C . The size distributions of larger and smaller groups are shown in Fig. 16(a). The range of diameter of the smaller group was $10\sim 60\ \mu\text{m}$ and the mode value was $20\ \mu\text{m}$. On the other hand, the range of larger group was $40\sim 100\ \mu\text{m}$ and the mode was $60\ \mu\text{m}$. The number of the particles used in this experiment (N_0) and that of ice crystals growing (N) are shown in the upper right corner in Fig. 16(a), respectively.

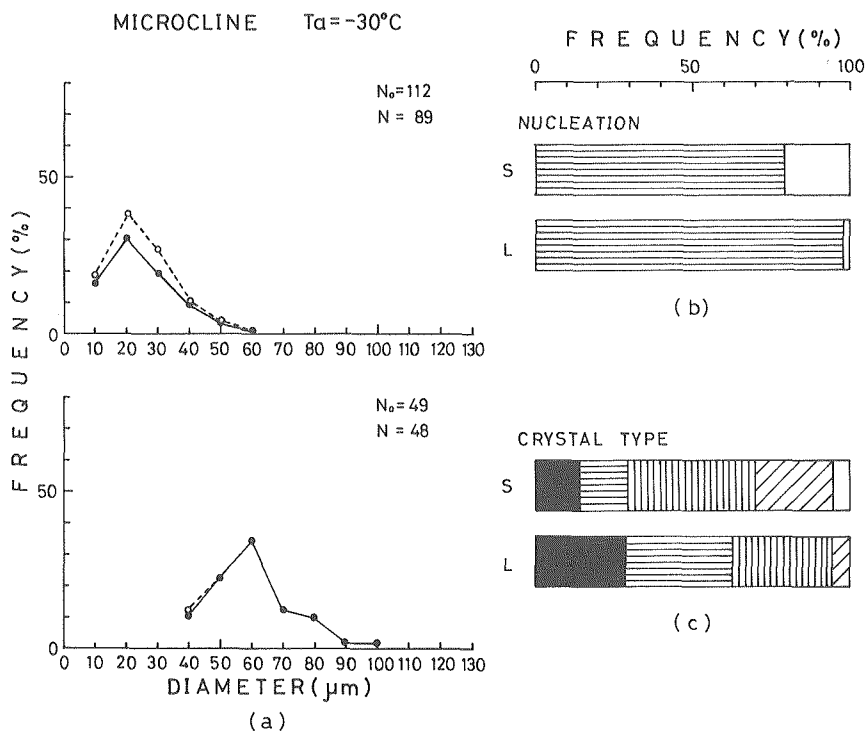

Fig. 16 Size effect of ice nuclei. (a) size distribution of smaller group and larger group of ice nuclei, (b) nucleation ratio of each group and (c) production ratio of various types of ice crystals of each group.

The nucleation ratio of the larger size group was greater than that of the smaller size group (Fig. 16(b)). On the crystal shapes, the single crystal growth was not predominantly in the larger size group. The production ratio of peculiar shaped crystals of the larger size group was greater than that of the smaller size group (Fig. 16(c)). The production ratio of combination of columns decreased and that of radiation assemblage of plates increased at the nucleation of larger size ice nuclei. A similar result was obtained when quartz was used as ice nuclei at -30°C . The larger ice nuclei were considered to have more activation sites than the smaller ice nuclei so that the nucleability of larger size ice nuclei was high (Takahashi, 1983).

3.2 Freezing of water droplets (Homogeneous nucleation)

The experiment of ice crystal growth from frozen water droplets was carried out at $T_a = -35^\circ\text{C}$. The number of frozen droplets examined was 20

tendency to become ice nuclei of peculiar shaped ice crystals readily.

2) The temperature at which peculiar shaped ice crystals were produced with ease depends on the substance of ice nuclei.

3) A relationship between the type of peculiar shaped ice crystals and the substance of ice nuclei, temperature, and the manner of nucleation is not clear.

4) The larger the substance of ice nuclei was, the more the polycrystalline ice crystals were and they grew to peculiar shaped ice crystals.

5) The production ratio of peculiar shaped ice crystals at the initial nucleation was higher than that at preactivation.

6) The production ratio of peculiar shaped ice crystals which grew from frozen water droplets was about 35% at -35°C although the number of frozen water droplets examined in this experiment was limited and the size of those was relatively large in the natural environment.

There is an experimental result in which the larger the size of water droplets and the lower the temperature at nucleation, the more polycrystalline frozen cloud droplets are made (Pitter and Pruppacher, 1973). Thus, it would be considered that polycrystalline ice crystals were grown from polycrystalline frozen water droplets. The larger the ice nuclei, the more the polycrystalline ice crystals are grown from the ice nuclei. Because the larger the ice nuclei, it would have more the number of activation sites (Takahashi, 1983). The water droplets and the ice nuclei used in this experiment were of one order size larger than those in nature. Therefore, it was concluded that polycrystalline ice crystals were grown more readily than single ice crystals.

Figure 18(a) shows the relationship between the nucleation ratio and the production ratio of polycrystals in this experiment. It appears that the production ratio of polycrystals is low when the nucleation ratio on a solid particle is high. It is considered that the single crystals are likely to be grown if the nucleability of ice nuclei is high because ice crystals are nucleated at lower supersaturation.

The percentage of peculiar shaped ice crystals to polycrystals is shown in Fig. 18(b). There appears to be a tendency that higher production ratio of peculiar shaped ice crystals is accompanied by the higher production ratio of polycrystals. This might suggest that the production of peculiar shaped ice crystals has a bearing on the crystalline boundaries of polycrystals and the growth condition of polycrystals (each crystal of polycrystals can grow in conditions of less water vapor than a single crystal in the same environment).

It is considered that the peculiar shaped ice crystals grow easily when the supersaturation is high (existence of liquid phase) as expected by the result of

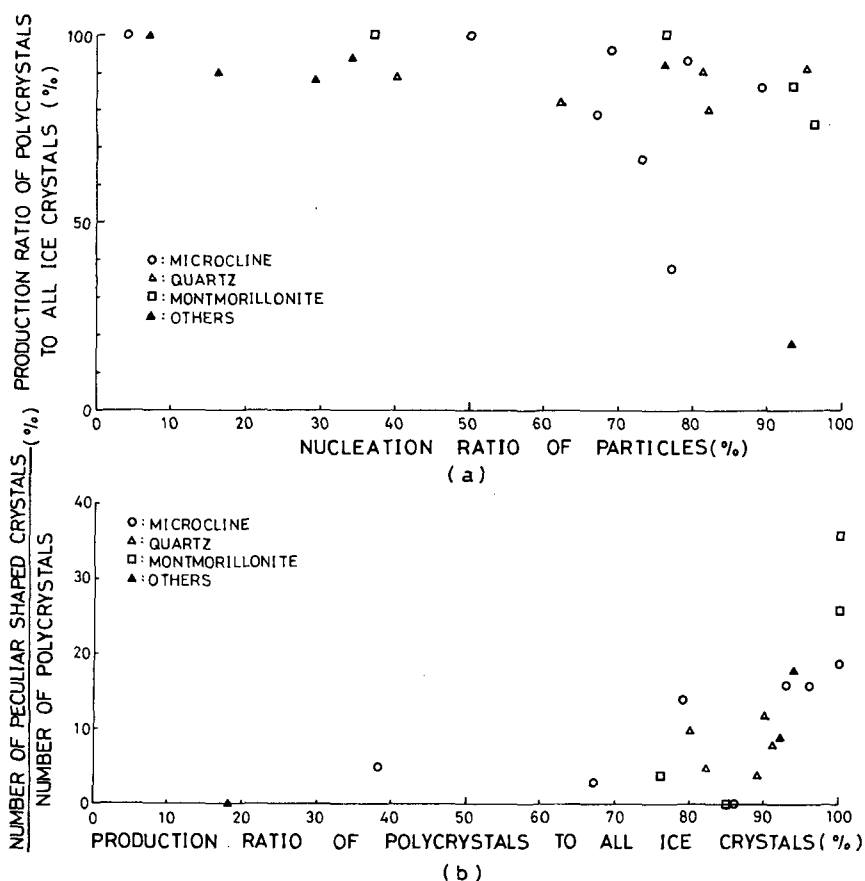

Fig. 18 (a) The relationship between nucleation ratio and production ratio of polycrystals. (b) The relationship between production ratio of polycrystals and that of peculiar shaped crystals.

experiments of frozen water droplets. This is supported by the following experimental results.

a) A preactivation phenomenon prevailed at a lower supersaturation than the initial nucleation, because some ice layer on the surface of ice nuclei remains (Roberts and Hallett, 1968). Therefore, a special site is likely to nucleate at lower supersaturation. In that condition the single ice crystal is readily grown and peculiar shaped ice crystals are difficult to grow at preactivation.

b) The substance of AgI is nucleated at lower supersaturation because the crystal structure of AgI resembles that of ice. Thus, most of the ice crystals made on AgI are single crystalline ice crystals.

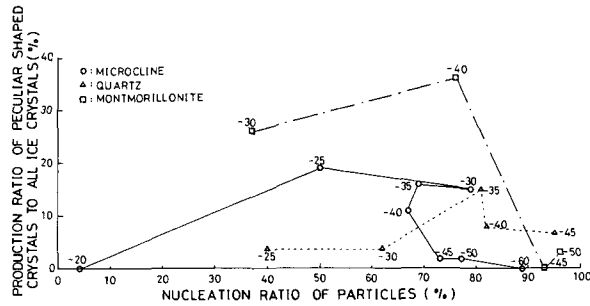

Fig. 19 The relationship between nucleation ratio and production ratio of peculiar shaped crystals.

Figure 19 shows the relationship between nucleation ratio of ice nuclei and the production ratio of peculiar shaped ice crystals with air temperature when microcline, quartz and montmorillonite were used as ice nuclei. It appears that the nucleation ratio increased with the decreasing of temperature roughly. There appears to be a suitable air temperature to each substance of ice nuclei at which peculiar shaped ice crystals are grown readily. Through this experiment the air temperature is -25°C for microcline marked by open circles, -35°C for quartz marked by open triangles and -40°C for montmorillonite marked by open squares. This air temperature might correspond to temperatures at which the nucleation mode changes from the condensation-freezing to deposition mode (Schaller and Fukuta, 1979). It might be considered that the nucleation process through the liquid phase is a sufficient condition for production of peculiar shaped ice crystals. The nucleation processes through the liquid phase are condensation-freezing on ice nuclei and the freezing of cloud droplets.

The center nuclei of snow crystals in nature were studied using a scanning electron microscope and an energy dispersive X-ray microanalyzer (Kikuchi et al., 1987). They considered that the percentage frequency of the chemical components of the center nuclei was higher in polycrystals than in single crystals as a whole in such a way that the chemical components of center nuclei of single crystals were made of relatively pure elements, and those of polycrystals were made of mixed and complex elements. Soil nuclei might consist of mixed nuclei with sea salt and human activity products. If the soil nuclei have a solvent on the surface, water droplets may be formed on the soil nuclei and may grow larger under water saturation. The larger the water droplets are, the more polycrystals are grown from water droplets (Pitter and Pruppacher, 1973). Polycrystals might be grown on mixed nuclei. Peculiar shaped snow

crystals are grown as a part of polycrystals. Therefore, ice nuclei whose surfaces are covered with a water layer appears to be the center nuclei of peculiar shaped snow crystals. This seems to correspond to the experimental result that the water saturation was a sufficient condition for making peculiar shaped snow crystals.

Acknowledgments

A part of the expense of this research was supported by the Grant-in-Aid for Scientific Research (A) "Studies on Snow Crystals of Cold Temperature Types" (Project No. 00542018), the Ministry of Education, Science and Culture of Japan, for which we would like to express our sincere thanks.

References

- Beckmann, W., 1982. Interface kinetics of the growth and evaporation of ice single crystals from the vapour phase III, Measurements under partial pressures of nitrogen. *J. Crystal Growth*, **58**, 443-451.
- Hallett, J. and B.J. Mason, 1958. The influence of temperature and supersaturation on the habit of ice crystals grown from the vapour. *Proc. Roy. Soc.*, **A247**, 440-453.
- Higuchi, K., 1956. A new method for the simultaneous observation of a large number of falling snow particles. *J. Meteor.*, **13**, 274-278.
- Houghton, H.G., 1950. A preliminary quantitative analysis of precipitation mechanisms. *J. Meteor.*, **7**, 363-369.
- Kajikawa, M., K. Kikuchi and C. Magono, 1980. Frequency of occurrence of peculiar shapes of snow crystals. *J. Meteor. Soc. Japan*, **58**, 416-421.
- Kikuchi, K., 1970. Peculiar shapes of solid precipitation observed at Syowa Station, Antarctica. *J. Meteor. Soc. Japan*, **48**, 243-249.
- Kikuchi, K. and N. Sato, 1984. On the snow crystals of cold temperature types. *Proc. Int. Conf. on Cloud Physics*, **9**, Tallinn, 169-172.
- Kikuchi, K., T. Taniguchi and H. Tsujimura, 1987. On the center nucleus of snow crystals and aerosol particles in Arctic Canada. "Studies on the Snow Crystals of Low Temperature Types and Arctic Aerosols" Hokkaido Univ., Japan (ed. K. Kikuchi), 178-211.
- Kobayashi, T., 1957. Experimental researches on the snow crystal habit and growth by means of a diffusion cloud chamber. *J. Meteor. Soc. Japan*, 75th Anniv. Vol., 38-47.
- Kobayashi, T., 1961. The growth of snow crystals at low supersaturations. *Phil. Mag.*, **6**, 1363-1370.
- Kobayashi, T., Y. Furukawa, K. Kikuchi and H. Uyeda, 1976a. On twinned structures in snow crystals. *J. Crystal Growth*, **32**, 233-249.
- Kobayashi, T., Y. Furukawa, T. Takahashi and H. Uyeda, 1976b. Cubic structure models at the junctions in polycrystalline snow crystals. *J. Crystal Growth*, **35**, 262-268.
- Lee, C.W., 1972. On the crystallographic orientation of spatial branches in natural polycrystalline snow crystal. *J. Meteor. Soc. Japan*, **50**, 171-180.
- Nakaya, U., 1954. *Snow Crystals, natural and artificial*. Harvard Univ. Press, 510pp.
- Pitter, R.L. and H.R. Pruppacher, 1973. A wind tunnel investigation of freezing of small

- water drops falling at terminal velocity in air. *Quart. J. R. Meteor. Soc.*, **99**, 540-550.
- Roberts, P. and J. Hallett, 1968. A laboratory study of the ice nucleating properties of some mineral particles. *Quart. J. R. Meteor. Soc.*, **94**, 25-34.
- Sato, N. and K. Kikuchi, 1983. Artificial making of snow crystals of cold temperature type (in Japanese with English abstract). *Geophysical Bull. Hokkaido Univ.*, **42**, 37-50.
- Schaefer, V.J. and R.J. Cheng, 1968. The effect of the nucleus on ice crystal structure. *Proc. Int. Conf. on Cloud Physics*, **5**, Toronto, 255-259.
- Schaller, R.C. and N. Fukuta, 1979. Ice nucleation by aerosol particles: Experimental studies using a wedge-shaped ice thermal diffusion chamber. *J. Atmos. Sci.*, **36**, 1788-1802.
- Takahashi, C., 1983. The effect of the ice nucleus on the shape of snow crystals. *Mem. Natl. Inst. Polar Res., Spec. Issue*, No. **29**, 121-126.
- Uyeda, H. and K. Kikuchi, 1976. On the orientation of the principal axis of frozen droplets. *J. Meteor. Soc. Japan*, **54**, 267-276.
- Yamashita, A., 1971. Skeleton ice crystals of non-hexagonal shape grown in free fall. *J. Meteor. Soc. Japan*, **49**, 215-231.
- Yamashita, A., 1973. On the trigonal growth of ice crystals. *J. Meteor. Soc. Japan*, **51**, 307-317.