



HOKKAIDO UNIVERSITY

Title	Linearized Deformation Process of a Fluid filled Crack under Non-Homogeneous Pressure and Its Implication to Volcanism
Author(s)	MAEDA, Itaru
Citation	Journal of the Faculty of Science, Hokkaido University. Series 7, Geophysics, 11(4), 707-724
Issue Date	2000-03-24
Doc URL	https://hdl.handle.net/2115/8857
Type	departmental bulletin paper
File Information	11(4)_p707-724.pdf



Linearized Deformation Process of a Fluid Filled Crack under Non-Homogeneous Pressure and Its Implication to Volcanism

Itaru Maeda

*Division of Earth and Planetary Sciences, Graduate School of science,
Hokkaido University, Sapporo 060-0810, Japan*

(Received November 30, 1999)

Abstract

Time dependent deformation of a crack containing fluid under nonuniform pressure is analyzed by a linearized crack model. The crack is a representative of a space in the earth's crust or mantle for magma or lava transportation. Weertman first analyzed such a crack deformation and claimed that a crack in the situation took a tadpole shape eventually when the crack length was sufficiently long. He did not give the time during which the crack shape reached the final form. Present model shows that the time duration is infinite for a fluid having finite viscosity. This indicates that Weertman's tadpole is never realized in real natural settings.

The present model also shows that the crack takes another tadpole shape with a long tail which keeps nonzero mass of fluid, i.e., magma. The longer the crack length is, the longer the tail is. Or to put it differently, for a fixed crack length, the lower the inner pressure is, the longer the tail is. From this, we deduce that a lava filled a crack started upward at the rim of a magma reservoir will become thin as its head goes up, if the lava supply from the reservoir is not sufficient. It is like a degeneration of a tadpole. This means that a lava transportation once started from a reservoir may come to a halt without solidification. The present model gives one of a mechanism of volcanic activity which not necessarily lead to eruption.

1. Introduction

Problem of magma ascent through cracks is considered first by Weertman (1971a, b). He showed that an upward moving crack took a critical configuration called a tadpole. It is clear that the results by Weertman can be applied only in the limit of infinite time future. This means that the image presented in the article by Hujii (1979) cannot be real. The reason why a crack needs infinite time to achieve the Weertman configuration is due to the viscous fluid inside it. He assumed a steady-state motion of a crack and equated the crack velocity to the fluid velocity averaged over the crack length. This

averaging ignores the fact that the velocity of fluid flowing a narrower section of the crack is slower than that of wider section. It is evident that existence of viscous fluid causes the deformation time dependent. Its time dependency may be expressed by a function of the form $\exp(at)$, where t is time with a constant a . If this is true, there is no stationary moving state with fixed crack configuration. Near the tail of the tadpole, width of the crack becomes extremely narrow and the fluid becomes nearly immobile.

To treat the problem of motions of a crack filled with fluid, we must solve a coupled problem of elasticity and viscous fluid dynamics, which is very difficult to handle. We have to make many approximations to handle the problem. Spence and Turcotte (1990) and Lister and Kerr (1991) attacked this problem.

The first work considered only mass conservation of the fluid contained in a crack. It does not take into account of elastic constraints. In other words, they ignored boundary conditions. Their "solution" seems extremely unnatural. The second work treats a case of constant supply of magma and seems to be more natural than the first. The condition of constant supply may be replaced by no supply physically. This corresponds to the case given by the first article with elastic effects.

Recently, Me'riaux and Jaupart (1998) solved dynamical elasto-viscous fluid problem for more realistic settings. Their solution has a bit strange character: Their magma reservoir (i.e., a fluid filled crack) moves along a boundary between two large elastic blocks. The motion is determined by conditions imposed on the opposite face of a block. In real situations, the blocks may be continental plates or its sub-blocks. If this is the case, the block will be sufficiently large and the conditions on one of the face would not affect to the detailed situation of the opposite face of the block. Along with this character, their work is a kind of tour de force and not easy to reconstruct.

Their work is still not satisfactory for the problem because they treat the motion of a crack in a critical configuration similar to Weertman's tadpole. In their work, it seems that time dependency of the deformation to reach a critical configuration is not taken into account. In this report, we consider the time dependency of crack deformation from an initial configuration to another one. For simplicity, we would not consider "motions" of the crack, because the motion strongly depends on the crack opening condition at the crack-tip, which is not known.

2. Model

Take a coordinate system: x - and y - axes are horizontal and z - axis is vertical. We consider a thin ellipsoidal crack and take the origin of the coordinate system at the center of the crack. The longest axis is vertical and the second major axis is in y -direction. A thin crack means that aspect ratios of the ellipses of vertical and horizontal cross sections are very small. We approximate this 3-dimensional crack with a 2-dimensional crack having unit width in y -direction.

The problem is to determine, as a function of time, a crack shape subjected to nonuniform pressure caused by density difference of lithostatic pressures inside and outside of the crack. The derivative of the pressure with respect to z corresponds to the buoyancy to the liquid material (i.e., magma) inside the crack. It is the sufficiently accurate assumption that the pressure distribution on the crack face is linear with respect to z . We are not interested in the purely elastic deformation process which is sufficiently quick. Time dependent deformation within our interest is slow and must be controlled by the fluid motion inside the crack. We must therefore specify the fluid motion to obtain the time dependent crack deformation.

We assume that the fluid motion is in z -direction and in a state of laminar flow. The fluid flow in the crack may be approximated by a fluid flow in a channel bounded by parallel planes, the width of which is the crack thickness (in x -direction) at z , $2b(t, z)$. The cross sectional area S of the flow is $2b(t, z)$. The flow must be time dependent but we assume that at each instance, the flow can be approximated by a steady flow. The flow velocity at z averaged over x -direction is

$$\bar{u} = -\frac{b^2(t, z)\nabla p}{3\eta} \quad (1)$$

where ∇p is the pressure gradient at z and η is the viscosity. This pressure gradient is the one acting on the fluid and not necessarily equal to the buoyancy. Then the mass current J is

$$J = \frac{2\rho'}{3\eta}(-\nabla p)b^3(t, z), \quad (2)$$

where ρ' is the density of the fluid (Landau and Lifshitz, 1987).

Now we consider a case in which, at an initial time, the pressure gradient is originated by buoyancy caused by the density difference of fluid and the surrounded medium, which will cause the fluid inside the crack to move upward.

The situation is not so simple as a case of two type of fluids with different densities or a case of a solid surrounded by a fluid. In the present case, a fluid is surrounded by elastic medium. The driving force for fluid per unit area consists of the buoyancy and elastic stress caused by crack deformation from equilibrium configuration. We call the later stress the deformation stress. If the upper edge of a crack does not break to extend the crack, the fluid motion must be terminated eventually, i.e., the driving force will become zero; the elastic deformation stress is balanced to the buoyancy.

In order to obtain a mathematical expression for the driving force, we must specify the situation more explicitly. We consider a case that the initial crack configuration (vertical cross section) is an ellipse which is an equilibrium shape of a 2 dimensional crack in a uniform elastic medium opened by a uniform inner pressure p_0 without gravity. At this stage, the deformation stress is zero by definition and, therefore, the driving force is purely made of buoyancy. As stated above, at the final stage, the buoyancy must be equal to the deformation stress. This means that the pressure gradient will be changed according to this deformation.

We make a linear approximation for the stress of the intermediate state. The total amount of deformation at the final configuration measured from the initial state will be denoted as Δb_f . Under the assumption of linear deformation, the effective pressure, which deforms the crack further, at deformation $\Delta b(t, z) (< \Delta b_f)$ will become

$$p(t, z) \propto 1 - \frac{\Delta b(t, z)}{\Delta b_f} \quad (3)$$

From this, the pressure gradient is determined. The pressure gradient is therefore a function of the deformation and so a function of time. The function p must be solved simultaneously with $b(t, z)$.

“Deformation” is actually a displacement in this case. Displacement is a spatially integrated (with respect spacial variables x and z) quantity of strain and therefore has non-local nature. We tacitly assume that the pressure gradient obtained by differentiating the non-local quantities with respect to z regains its local nature at the original local points. This “locality” still has integrated nature with respect x but as for the displacement (of the crack face)-pressure (acting on the crack face) relation x -dependence would not cause trouble.

We must give comments on negative displacements $b(t, z)$ which is predicted by Weertman’s theory when an initial pressure is low and crack length is

longer than the critical length. This state never occur in real. We think that this displacements simply express stress states. In the elastic theory, the deformation (strain) has one to one correspondence (injection) with stress. Even if actual displacements of a crack face is hampered by some obstacles, elastic stress still is acting though it is balanced by the force exerted by the obstacles.

Now we assume that the final configuration of a crack is equal to that given by Weertman (1971a) for a static crack with the crack length c , the deformation of which is calculated by the dislocation pile up model. It is simply expressed by an ellipse subjected to a static pressure which is a linear function of z (expressing a hydrostatic pressure difference between inside fluid and outside country rock). Dividing Weertman's expression by 2, we obtain the final configuration of displacement b_s of the crack face, because his definition of the displacement is the aperture of the crack, so it is twice as large as our displacement of a crack surface :

$$\begin{aligned}
 b_s(z) &= \left(\left(\frac{V_0}{\pi c^2} \right) + \frac{(1-\nu)\Delta\rho g z}{2\mu} \right) \sqrt{c^2 - z^2} & (4) \\
 &= A \left(p_0 + \frac{\Delta\rho g z}{2} \right) \sqrt{c^2 - z^2}, \\
 A &= \left(\frac{2(1-\nu^2)}{E} \right)
 \end{aligned}$$

where we denoted rigidity μ , Young's modulus E , Poisson's ratio ν , and the gravity g . The density difference $\Delta\rho = \rho - \rho'$, where ρ is the density of the surrounding rock. Fig. 1 shows the displacements by a uniform pressure p_0 and three relative pressure cases of Weertman's crack configurations. The displacements are normalized.

The first term in $b_s(z)$ is just the same as the displacement of a 2D thin crack subjected to internal uniform pressure p_0 , given by Sneddon et al. (1969). The second is simply the p_0 replaced by $\Delta\rho g z/2$. We must remember that the effective extra pressure is half of the density difference pressure $\Delta\rho g z$. From this equation, we know that Δb_f defined above is

$$\Delta b_f = b_s - A p_0 \sqrt{c^2 - z^2} \tag{5}$$

Total mass in Weertman's expression is preserved. The first term always gives half of the initial mass if it is integrated with respect z from $-c$ to c . For the second term, it does not contribute to the total mass because the square function is even with respect to the origin while buoyancy force is odd. This means that, for cases with longer crack length than critical one, the expression does not give

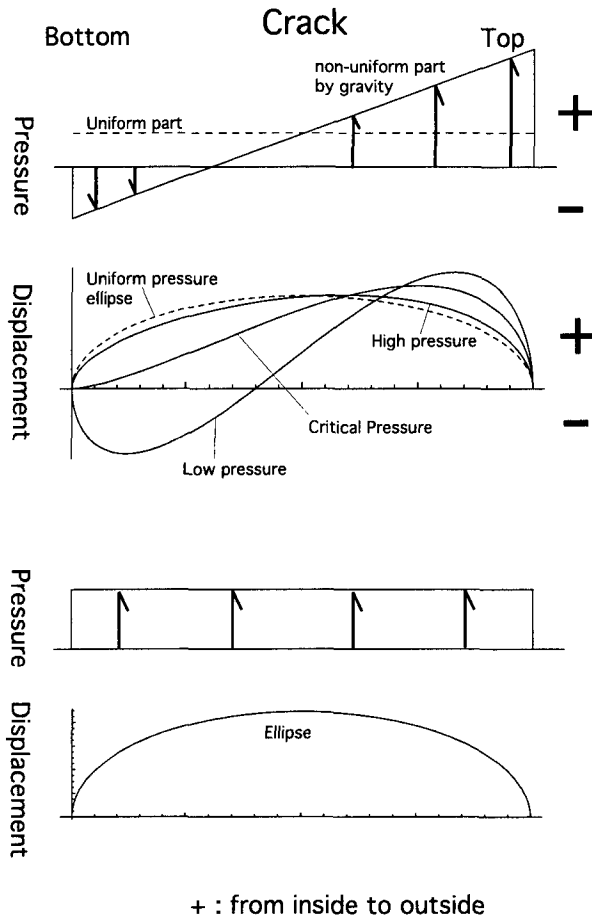

Fig. 1. Theoretical crack cross sections under different pressures, uniform or non-uniform, and high or low. Displacements are arbitrarily scaled.

correct deformation and mass is not preserved because negative displacement cannot occur in the actual situation. Weertman (1971a) pointed out that at the moment when the crack length exceeds the critical one, the bottom edge would be closed to keep the length being critical.

Weertman's result shows that when the pressure is just anti-symmetric, the positive pressures reduces the effect of negative pressures acting on the other half crack surface to the half, and vice versa. To be the displacement positive, we must have

$$p_0 - \frac{\Delta\rho g c}{2} \geq 0 \tag{6}$$

The effective pressure must change from $\Delta\rho g z$ at time 0 to zero at $t = \infty$ by definition :

$$\begin{aligned} p(0, z) &= \Delta\rho g z \\ p(\infty, z) &= 0 \end{aligned} \tag{7}$$

while the aperture b will change, according to Weertman' formula, from an ellipse given by

$$b(0, z) = A p_0 \sqrt{c^2 - z^2} \tag{8}$$

to

$$b(\infty, z) = A \left(p_0 + \frac{\Delta\rho g z}{2} \right) \sqrt{c^2 - z^2} \tag{9}$$

As was pointed out above, the result of Weertman's formula that the effective extra pressure is half of the buoyancy force is due to an elastic character of the surrounding medium and not to the viscous effect of fluid. The problem is to obtain a fluid driving force $p(t, z)$ as a function of time.

Total deformation Δb_f due to the effective pressure $p(0, z)$ given by (7) is

$$\begin{aligned} \Delta b_f &= b(\infty, z) - b(0, z) \\ &= A \frac{\Delta\rho g z}{2} \sqrt{c^2 - z^2} \end{aligned} \tag{10}$$

According to the formula (3), we obtain

$$p(t, z) = \Delta\rho g z \left\{ 1 - \frac{b(t, z) - b(0, z)}{\Delta b_f} \right\} \tag{11}$$

We may obtain a pressure gradient, negative of which is the driving force of the fluid upward, as a function of t and z by differentiate it with respect to z :

$$\begin{aligned} \nabla p &= \frac{\partial p(t, z)}{\partial z} \\ &= \partial_z \left[\Delta\rho g z \left\{ 1 - \frac{2(b(t, z) - b(0, z))}{A \Delta\rho g z \sqrt{c^2 - z^2}} \right\} \right] \end{aligned} \tag{12}$$

For a crack initially elliptic, the derivative will diverge at the both ends. For other z , this pressure gradient is employed to the mass conservation equation :

$$\begin{aligned} \frac{\partial m(t, z)}{\partial t} &= -\nabla J = J(t, z + \Delta z) - J(t, z) = -\partial_z J \cdot \Delta z + \dots \\ m(t, z) &= \rho' \{ S(t, z + \Delta z) + S(t, z) \} \Delta z / 2 \end{aligned}$$

where J is given by (2). In the first equation, we retained up to second order terms. We denote the mass in a range from z to $z + \Delta z$ the mass m at z . The equation for the mass is a linear approximation. If the crack is sufficiently flat, we may replace it simply by $\rho' S(t, z) \Delta z$.

For incompressible fluid, we have obtained a fundamental equation for time dependent deformation of a crack under gravity.

$$\frac{\partial b_a(t, z)}{\partial t} = -\frac{\partial}{\partial z} \left[\frac{b^3(t, z)}{3\eta} \frac{\partial}{\partial z} \left\{ \frac{\Delta \rho g z b(0, t) - 2p_0 b_a(t, z)}{b(0, t)} \right\} \right] \quad (13)$$

The initial condition and boundary condition are as follow :

$$\begin{aligned} b_a(t, z) &= b(t, z) - b(0, z), \\ b_a(0, z) &= b_a(t, -c) = b_a(t, c) = 0, \end{aligned}$$

and a condition given by (6).

The domains of variables are

$$\begin{aligned} -c &\leq z \leq c \\ 0 &\leq t \end{aligned}$$

It is clear that this parabolic equation has linear dependence on the inverse of viscosity. Therefore, the system response in time is in linear relation with the inverse of viscosity : lower viscosity of one order of magnitude results in one order of magnitude quick response.

3. Numerical results

Convergence of numerical integration of equation (13) is rather slow. Fig. 2 shows total displacements from an initial configuration as a function of the spacial step size of the calculations. Because this model retains the conservation law of mass, the final displacement must be anti-symmetric with respect to the crack center if the calculations converged. It can be seen from the figure that, for a crack having the length of 200 m, the step size of 0.2 m is still not sufficient as observed that the cross points of positive and negative displacement apparently deviate from the center. An interpolation of the cross points shows 1/1,000 m = 1 mm is needed for good convergence but it is too much time consuming. Because we do not need numerical accuracy for the present purpose, we calculated following figures with the step size of 0.2 m.

We use fixed values for the constants defined in the model. They are as follow : Young's Modulus $E = 2 \times 10^9$, Poisson's ratio $\nu = 0.3$, density difference $\Delta \rho = 0.2 \times 10^3$, Viscosity $\eta = 10^3$ in MKS-unit system. For example, the unit of

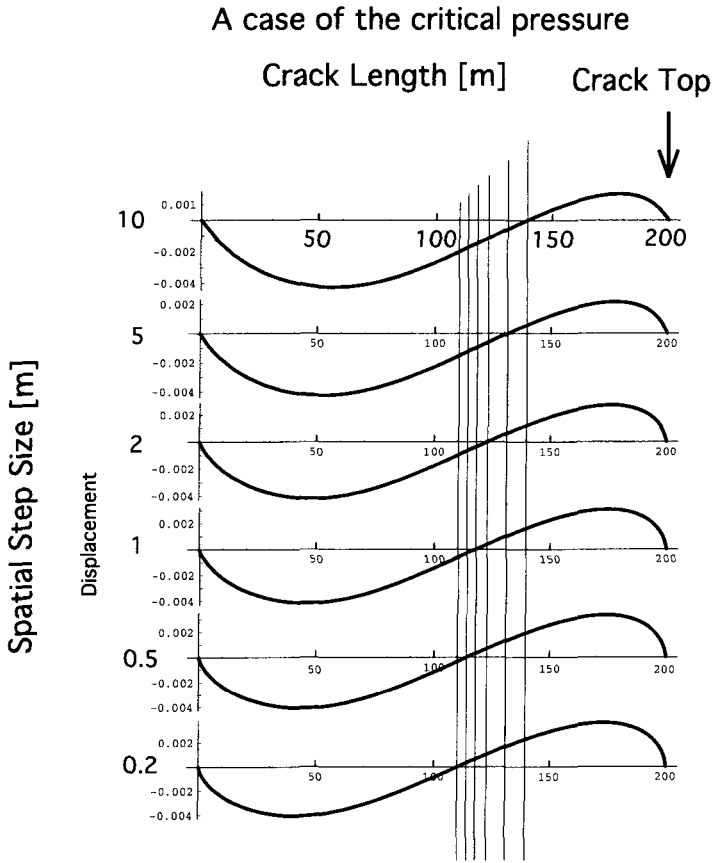

Fig. 2. Convergence test. Sinusoidal curves indicate displacements integrated with assigned step sizes. Theoretically, the cross point of the displacement from positive to negative must be at the center of the crack (at 100 m point).

viscosity is Pa·s. The crack length is mainly 200 m and the length of 300 m is only for comparison. The assigned viscosity is the lower end of possible values for magma or much lower. This means that the time constant for deformation in natural situations must be much longer than the calculated one. As pointed out in the end on the last section, how long it is may be deduced by comparing the possible viscosities and the fix one.

We calculated three pressure cases, just the critical pressure, and the lower and the higher than that pressure. The critical pressure is given by (6) with the equal sign and means that, under this pressure, a crack having a given length takes the critical configuration, i.e., Weertman's Tadpole. The aspect ratio of

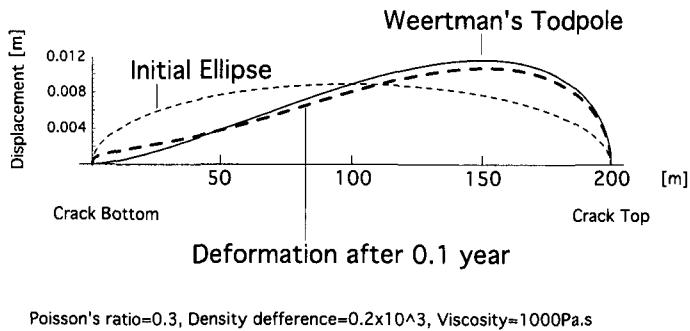

Fig. 3. Weertman's (solid line) and numerically integrated (bold broken line) cross sections of a crack under the critical pressure. A uniform pressure case (thin dotted line) is also given for comparison.

a crack opened by the critical pressure without gravity is about $1/10,000$. For the 200 m crack, the thickness is only 1cm which is extremely narrow for a fluid to flow through.

Fig. 3 shows the half cross sections of the crack under critical pressure p_c . In the figure the initial shape (an ellipse) is given by a thin broken line, Weertman's tadpole a solid thin line, the calculated shape after 0.1 year a bold broken line. Theoretically the tadpole is the final shape attained after infinite time. From the figure, we observe that after 0.1 year, overall deformation makes good progress to the final shape but at the bottom end of the crack deformation has not progressed.

The process of deformation may be visualized by plotting them in 3-D figures. Fig. 4 shows the deformation, cross section, relaxation pattern, and driving force as a function of time t and vertical coordinate z . The deformation in the figure is the displacement of the crack face measured from the initial ellipse. The driving forces nearly reached to zero in the upper part of the crack but did not in the lower part. This is caused by the flow law; the narrower the channel is, the slower the flow becomes.

Fig. 5 is the case of pressure of $p_c - 8 \times 10^4 \text{Pa}$, a lower pressure case than the critical. This also includes the displacement. Weertman's final form has an imaginary crack configuration in the lower part of the crack. The bold broken line shows calculated cross section after 2 years. Only upper most part gains the fluid mass and becomes thick and the remaining lower part still keeps open. It is clear that the crack never take Weertman's tadpole shape but takes a tadpole shape having a longer tail. The tadpole never grow to a frog, so to speak. We call this a younger tadpole.

Displacement 200m - critical crack

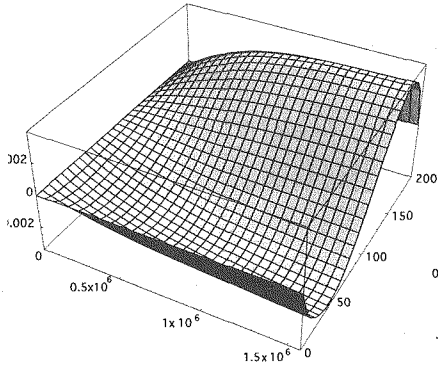

Relaxation Pattern

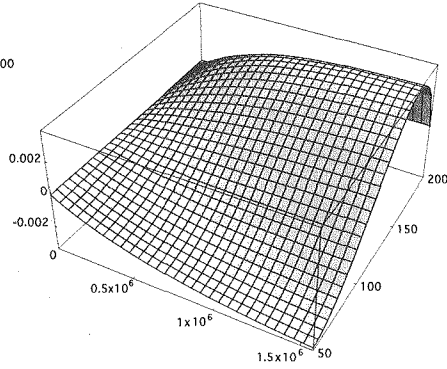

Cross Section

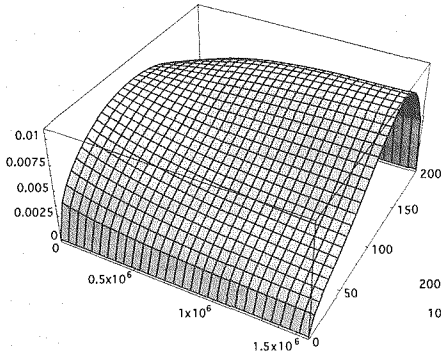

Driving Force

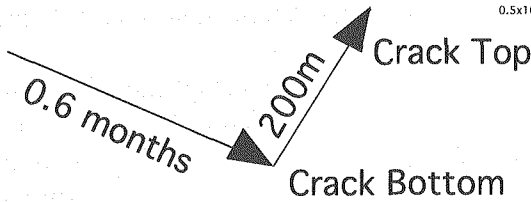
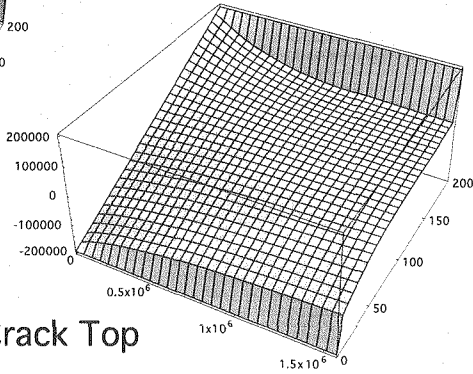

Fig. 4. Deformation process for the case given in Fig. 4.

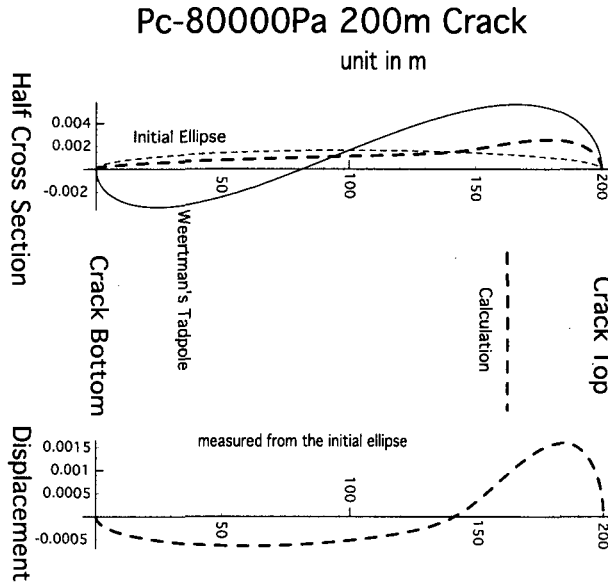

Fig. 5. Cross section and displacement for a low pressure case. Thin short broken line gives the initial ellipse, bold broken line the calculated after 0.1 year, and solid line the Weertman's tadpole.

As in the critical pressure case, we plot the variations in Fig. 6. From the relaxation pattern, we observe the time constant is about 2 years, though we would not claim the value being precise (we do not need precise values for the present purpose). We can see from the figure that, to agree with the fact that the crack keeps open in lower part, the driving force would not reduce to zero.

For a higher pressure case than the critical, the deformation is relatively small and the time constant is also small. Fig. 7 shows a case of pressure ten times larger than the critical one. The final form given by Weertman's theory and numerically calculated one after about 1 hour are the same within the resolution of the figure. The displacement is anti-symmetric almost perfectly. From the variations given in Fig. 8, we see that the deformation process reaches its final configuration quickly.

Finally, we give an example of a longer crack case for comparison with the results given above. Fig. 9 and 10 show the cross sections and displacement of a crack which has 300 m length and contains fluid of the same mass as the critical pressure case of 200 m crack. Because we are considering incompressible fluid, that the fluid masses are the same means the same crack volumes. The pressure is lower than the critical pressure for a crack having length of 300

$P=P_c-80000$ Pa case

Displacement

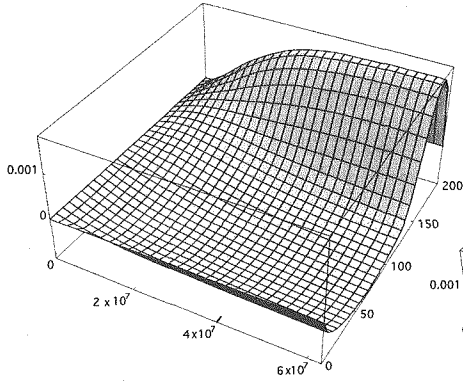

Relaxation Pattern

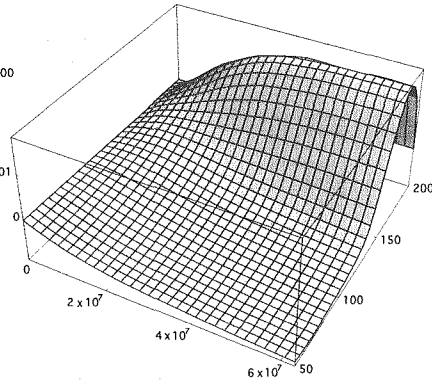

Cross Section

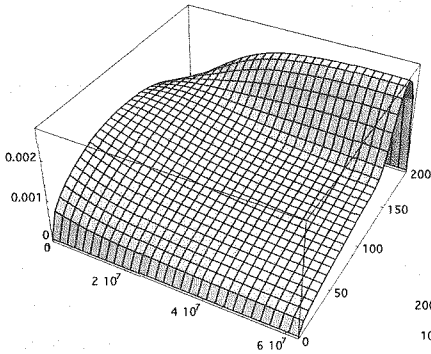

Driving Force
(Pressure)

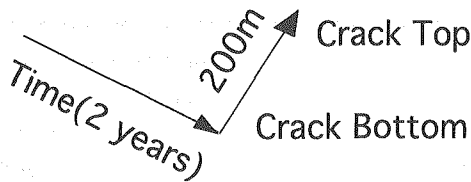
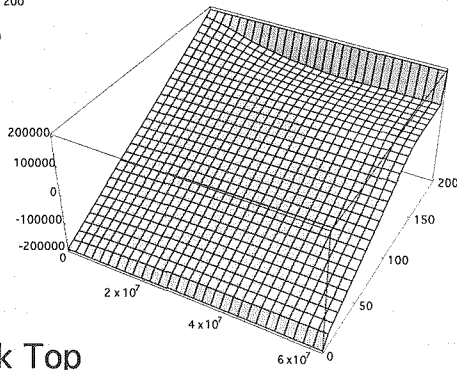

Fig. 6. Deformation process for the case given in Fig. 5.

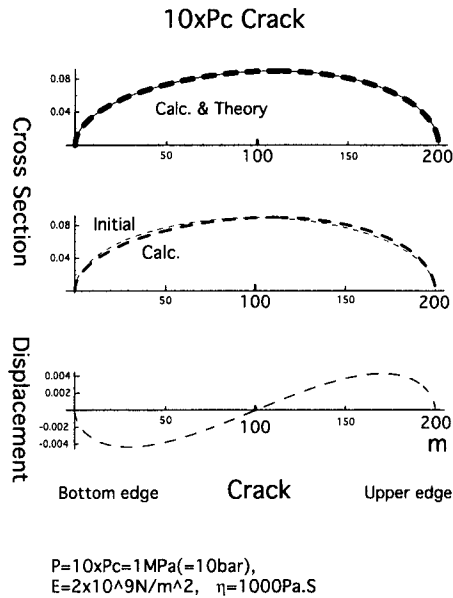

Fig. 7. Cross section and displacement for high pressure case. The convergence is quick. Numerical and analytical displacements are indiscernible.

m. It takes longer time to approach to a final form (a younger tadpole) than the critical case of 200 m crack (compare Fig. 4 with Fig. 10).

4. Discussion

In this section, we consider the implications of the results given above to volcanic activities; magma ascent to a reservoir and lava discharge from a reservoir. The first thing to be mentioned relates Weertman's prediction; when pressure is low, the crack tip at the bottom is closed by lithostatic pressure. We show this is not true for realistic setting.

When pressure opening a crack is sufficiently high, the crack shape is nearly an ellipse, so the effect of vertical lithostatic pressure gradient on the crack shape is negligible. The time constant to relax the crack shape to a final one is rather short. We call the time constant the deformation time constant. But as the pressure reduces, the lithostatic pressure gradient becomes considerable and the crack shape deviates from an ellipse and has a thin part which we call a tadpole tail. In the thin part of the crack, the velocity of fluid flow is reduced so that the crack shape never reaches to Weertman's tadpole except the case of

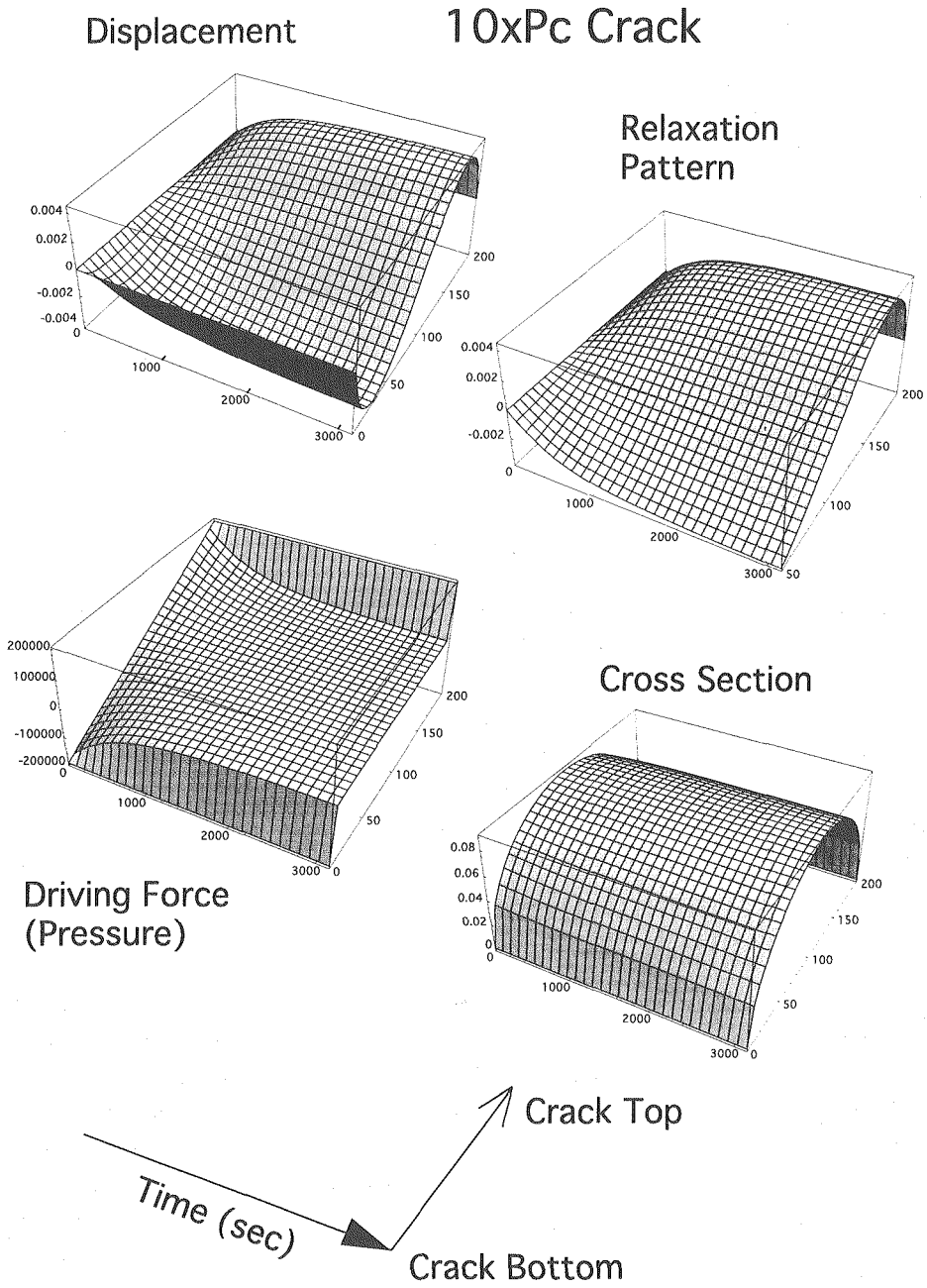

Fig. 8. Deformation process for the case given in Fig. 7

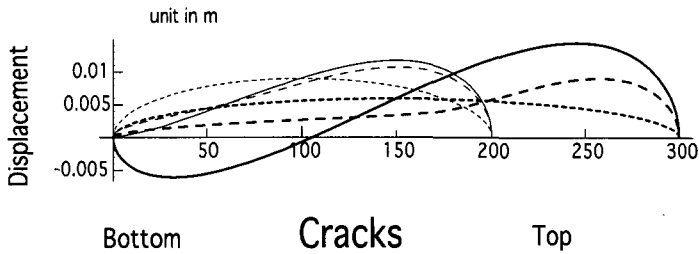

Fig. 9. Cross sections of the 300 m crack which has the same volume with a 200 m crack under the critical pressure. The displacements of the 200 m crack are also given for comparison.

an ideal fluid.

Even at the viscosity of $1,000 \text{ Pa}\cdot\text{s}$, the deformation time constant is the order of months for 200 m cracks. Because the time constant is proportional to the inverse to the viscosity, more realistic viscosity of the $1 \text{ MPa}\cdot\text{s}$ gives the constant the order of 100 years. As the pressure reduces further, the tail becomes longer and the crack shape within finite time duration becomes less resemble to Weertman's tadpole. This concludes that Weertman's prediction is not true. From this, it is clear that the magma ascent model given by Hujii (1979) is a complete fake.

If a crack extends keeping the fluid volume (mass) constant, the effective crack opening pressure is reduced because the critical pressure at this extended length is increased as given by equation (6). The extension, therefore, simply results in a thinner crack with a longer tail and in longer time constant as shown the case study for 200 m and 300 m cracks. Because the tail keeps fluid mass (i.e., never closes), the head (main body of the tadpole) becomes small. As the crack extends upward, the head becomes smaller and the velocity of fluid also is slowed.

This situation is considered to be just applicable to cases of volcanic activities in which eruption may occur or may not. In some cases, volcanic activities results in a small scale eruption. In other cases, only gas effusions are observed along with volcanic earthquakes. Such situations may controlled stochastically; one mechanism is the initial crack size at the rim of a magma reservoir. It is well known that crack size (length) is determined at random.

In a too long initial crack, lava from the reservoir move slowly and may be solidified. For a shorter initial crack, lava flow will quick and results in a stress concentration at the upper edge, which causes crack extension which may accompany an earthquake. If there is no magma supply subsequently, the

300m-crack having the same volume as a critical crack of 200m length

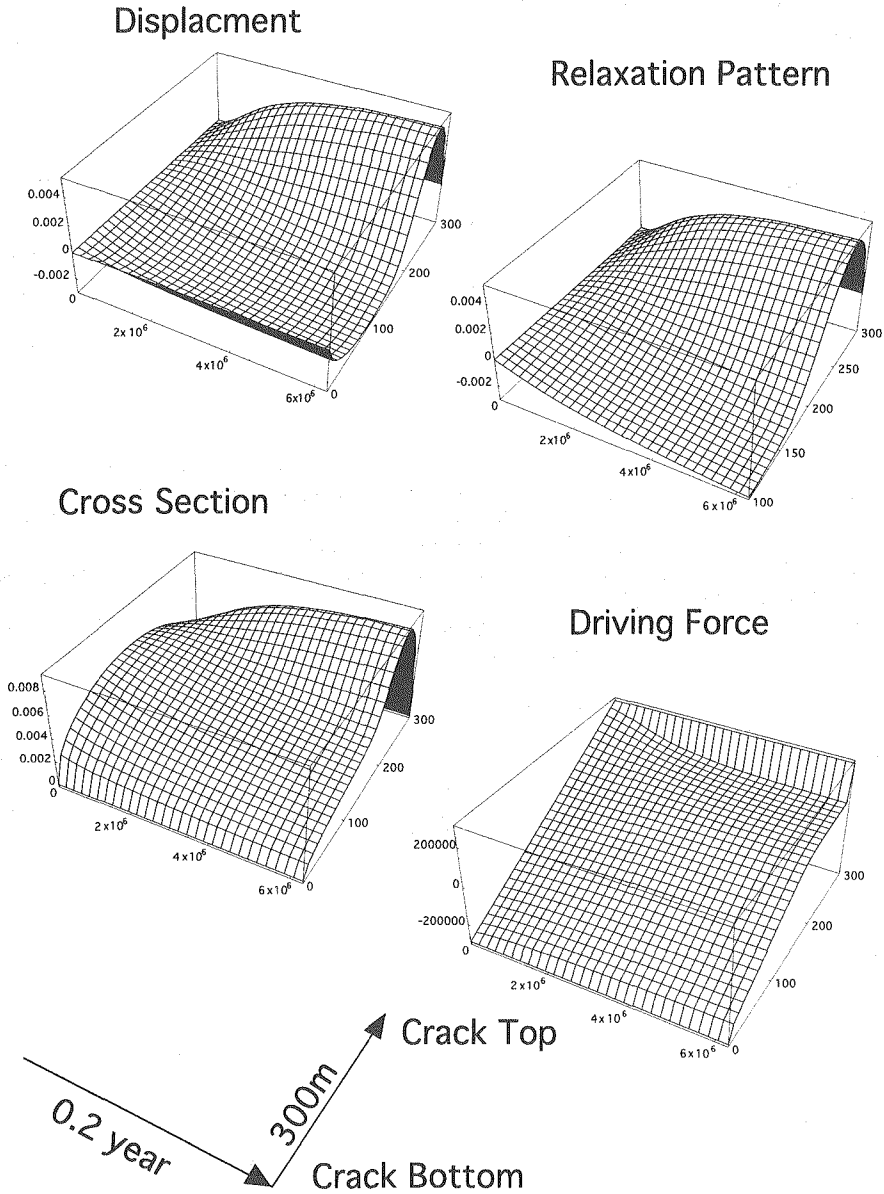

Fig. 10. Deformation process for the 300 m crack given in Fig. 10.

ascending lava quickly loses its inertia. Whether there is subsequent magma supply or not may also be determined stochastically. Present model gives semi-quantitative mechanism by which magma or lava once started from the reservoir to earth's surface comes to a halt virtually. This mechanism needs not solidification of the lava to stop.

5. Summary

We made a simplified analysis for crack deformation under inhomogenous pressure caused by gravity. The analysis shows that Weertman's tadpole is never attained and Hujii's magma ascent model is a complete fake. The analysis also gives a mechanism to halt a once ascending lava motion without solidification.

References

- Hujii, N., 1979. Magma ascent., 2-nd chapter in Chikyukagaku 7, volcano, Iwanami, 1979.
- Landau, L.D. and E.M. Lifshitz, 1987. Fluid Mechanics, Pergamon Press.
- Lister, J.R. and R.C. Kerr, 1991. Fluid-Mechanical models of crack propagation and thier application to magma transport on dykes. *J. Geophys. Res.*, **96**, 10049-10077.
- Me'riaux, C., and C. Jaupart, 1998. Dike propagation through an elastic plate. *J. Geophys. Res.*, **103**, 18295-18314.
- Spence, D.A. and D.L. Turcotte, 1990. Buoyancy-driven Magma Fracture : A mechanism for ascent through the lithosphere and the emplacement of diamonds. *J. Geophys. Res.*, **95**, 5133-5139.
- Sneddon, I.N. and M. Lowengrub, 1969. Crack Problems in the Classical Theory of Elasticity, John Wiley & Sons.
- Weertman, J., 1971a. Theory of water-filled crevasses in glaciers applied to vertical magma transport beneath oceanic ridges. *J. Geophys. Res.*, **76**, 1171-1183.
- Weertman, J., 1971b. Velocity at which liquid-filled cracks move in the earth's crust or in glaciers. *J. Geophys. Res.*, **76**, 8544-8553.