



HOKKAIDO UNIVERSITY

Title	A REVISION OF THE JAPANESE EUMENIDAE (HYMENOPTERA, VESPOIDEA)
Author(s)	Yamane, Seiki
Citation	Insecta matsumurana. New series : journal of the Faculty of Agriculture Hokkaido University, series entomology., 43, 1-189
Issue Date	1990-08
Doc URL	https://hdl.handle.net/2115/9855
Type	departmental bulletin paper
File Information	43_p1-189.pdf



A REVISION OF THE JAPANESE EUMENIDAE
(HYMENOPTERA, VESPOIDEA)

By SEIKI YAMANE

Abstract

Yamane, Sk. 1990. A revision of the Japanese Eumenidae (Hymenoptera, Vespoidea). *Ins. matsum. n. s.* 43: 1-189, 7 tabs., 366 figs.

The Japanese forms of Eumenidae are revised, and 54 species (77 forms in total) are recorded. The following five forms are described as new to science: *Pararrhynchium oceanicum* (Ogasawara Is.), *P. o. miyanoi* (Ogasawara Islands), *Symmorphus carinatus* (Shikoku), *S. iwatai* (Honshû), and *S. tsushmanus* (Tsushima Is.). New synonyms are: (*Stenodynerus rufomaculatus kikaiensis* Sk. Yamane) = *S. rufomaculatus*, (*S. yambara* Sk. Yamane et Gusenleitner) = *S. kusigematii*, (*Rhynchium haemorrhoidale samurai* Giordani Soika) = *R. quinquecinctum fukaii*, (*Anterhynchium flavomarginatum luctuosum* Giordani Soika) = *A. f. hanedai*, (*Ancistrocerus yamane* Giordani Soika) = *A. oiventris*, and (*Eumenes samurai rufescens* Giordani Soika) = *E. micado*. *Ancistrocerus parietinus* is newly recorded from Japan and numerous new localities are presented for the known species. The original description of *Euodynerus bicingulatus* Giordani Soika well agrees with small specimens of male *Anterhynchium flavomarginatum micado*. The former is possibly a synonym of the latter.

The eumenid fauna of Japan is characterized by many Palearctic, some Oriental and some endemic elements. But it lacks some of the genera widely distributed in the Palearctic region such as *Pseudepipona*, *Antepipona*, etc. On Sado-ga-shima and other islands located near the Japanese mainlands, the fauna is rather poor, with no endemic forms. Although the fauna is much poorer, the Izu Islands harbor one endemic form at subspecies level, *Stenodynerus tokyanus flavoscutellatus*. Of the 13 eumenid forms so far known from the Tsushima Islands, at least one is no doubt a Korean element (*Eumenes punctatus*), and two are apparently endemic (*Anterhynchium flavomarginatum tsushimorum* and *Symmorphus tsushmanus*). Two of the five species known to occur on the Ogasawara Islands are supposed to be native. Both are endemic and very peculiar in morphology and color pattern, and are each differentiated into two subspecies occurring in the Haha-jima and Chichi-jima group. The Ryûkyû Eumenidae are composed of Palearctic, wide-ranging, endemic and Oriental elements. The Northern Ryukyus are dominated by Palearctic and wide-ranging elements, the Central Ryukyus by wide-ranging and endemic elements, and the Southern Ryukyus by Oriental and wide-ranging elements. The largest gap in species composition is found between Amami-ôshima and Yaku-shima. Subspecies differentiation and regional convergence in color pattern among unrelated species are most remarkable in the Ryûkyû Islands.

Author's address. Department of Biology, Faculty of Science, Kagoshima University, Kagoshima, 890 Japan.

Contents

I. Introduction	3
Acknowledgements	4
II. Materials and survey areas	5
III. Family Eumenidae (Potter wasps)	11
1. Taxonomy	11
2. Biology	13
3. Eumenids as natural enemies of pests	14
IV. Characters and their conditions	15
V. Taxonomy of the Japanese Eumenidae	20
Key to the Japanese genera of Eumenidae	20
Genus <i>Discoelius</i> Latreille	22
Genus <i>Stenodynerus</i> Saussure	25
Genus <i>Allodynerus</i> Blüthgen	41
Genus <i>Euodynerus</i> Dalla Torre	46
Genus <i>Rhynchium</i> Spinola	63
Genus <i>Anterhynchium</i> Saussure	69
Genus <i>Okinawepipona</i> Sk. Yamane	83
Genus <i>Pararrhynchium</i> Saussure	87
Genus <i>Orancistrocerus</i> Vecht	95
Genus <i>Ancistrocerus</i> Wesmael	98
Genus <i>Symmorphus</i> Wesmael	113
Genus " <i>Pachymenes</i> " Saussure	135
Genus <i>Oreumenes</i> Bequaert	137
Genus <i>Eumenes</i> Latreille	140
Genus <i>Delta</i> Saussure	154
Genus <i>Pseumenes</i> Giordani Soika	159
Genus <i>Pseudozumia</i> Saussure	162
VI. Distribution pattern of the Eumenidae in some insular regions	164
1. Sado-ga-shima	165
2. Izu Islands	166
3. Tsushima Islands	167
4. Ogasawara Islands	168
5. Ryūkyū Islands	169
References	177
Appendix	185
Index	186

I. INTRODUCTION

The Eumenidae are a large diplopterous family containing 177 extant genera (Carpenter, 1986) and more than 2000 species in the world. They are all predators, hunting lepidopterous or coleopterous larvae for their young (Iwata, 1971). They are principally solitary wasps, even when gathering around suitable nesting sites. Some species of the genus *Zethus* and a few other genera are known to be communal nesters, though it is not certain whether they co-operate in provisioning. In still others, the mother wasp cares for her young and progressively provisions larval cells with prey. In addition, in the eumenids, in general, oviposition takes place prior to provisioning. All this shows that the Eumenidae represent an incipient stage in the evolution of sociality, and they have been paid increasing attention by insect sociologists.

Another important aspect in their biology is a potential role in controlling agricultural and forest pests. Although at present we have only a few experiences in managing them as useful predators (Takeshima, 1971; Lee, 1984), some eumenids may be involved in the integrated control of leaf-eating insect pests such as microlepidopterous larvae.

Undoubtedly an essential step toward a comprehensive understanding of biology and behavior of eumenid wasps is to establish a sound classification system of them. The Japanese Eumenidae were first studied taxonomically by European entomologists such as Smith (1852, 1873), Pérez (1905), Schulthess (1908, 1934), Cameron (1911) and others. By 1931 Matsumura had recorded eleven species from Japan including the Ryukyus. In 1930s, an important progress was made by Yasumatsu who studied material collected by Iwata in the course of his behavioral studies of eumenids as well as material in the collection of the Entomological Laboratory, Kyushu University. His treatments of species were, however, often erroneous, chiefly because he did not examine type specimens deposited in European institutes.

Since 1940s up to now, A. Giordani Soika of Italy has continued to study Japanese eumenids on the basis of specimens sent from Japan. He has compared them with abundant material gathered from all over the world and including type specimens. However, his studies on Japanese Eumenidae have exclusively been based upon dead material from restricted localities, so that he has sometimes failed in detecting sibling species and in recognizing subspecies. Further, he has not revised the Japanese Eumenidae as a whole.

The main purpose of the present study is to revise the eumenid fauna of Japan as completely as possible, based upon all the efforts previously made by many authors and upon my own study initiated in the early 1970s when I was at the Entomological Institute, Hokkaido University as a postgraduate student. Revisions of some groups including many new forms have already been published by me in co-operation with Mr. T. Tano and others. In the present paper I will enumerate 54 species, of which four are new to science. In order to facilitate future biological study, a summary of nesting behavior is given for each species whenever information is available. This is based mainly on Iwata's observations, but partly also on unpublished data collected by me or several other hymenopterists. Because the scientific names adopted by Iwata in his papers are to be critically revised, I have examined the Iwata collection preserved at Kobe University to determine the correct names of the wasps studied by him.

Geographical distribution is discussed with special emphasis on small islands. Above all, the Ryûkyû Archipelago is very interesting because of its geographical position

(between the Kyûshû mainland and Taiwan) and a large number of islands included. Analyses are made regarding the relative abundance of Oriental and Palearctic elements, area-species relation, competitive exclusion among species with similar nesting habits, and regional convergence in color pattern among non-related species on some islands.

Acknowledgements. I wish to express my cordial thanks to Prof. Sadao Takagi (Hokkaido Univ.), Prof. Toshio Nakashima (Hokkaido Univ.), Prof. Takehiko Nakane (Chiba-shi), Prof. Mitsuru Hotta (Kagoshima Univ.) and Prof. Shôichi F. Sakagami (Hokkaido Univ.) for their kind guidance and constant encouragements. Prof. S. Takagi, Prof. Hans Mori (Hokkaido Univ.) and Dr. Tosio Kumata kindly read through earlier drafts of the manuscript.

My hearty thanks should also be expressed to Dr. Masaaki Suwa (Hokkaido Univ.), Prof. Setsuya Momoi (Kobe Univ.), Dr. Tikhiko Naito (Kobe Univ.), Dr. Yasuo Maeta (Shimane Univ.), Prof. Yoshihiro Hirashima (Kyushu Univ.), Dr. Osamu Tadauchi (Kyushu Univ.), Dr. Shuichi Ikudome (Kagoshima Women's Junior College) and Prof. Seiji Azuma (Univ. Ryukyus) for permitting me to study valuable eumenid collections in their care and their helpful suggestions.

My thanks are extended to Dr. A. Giordani Soika (Museo Civico Storia Nat., Venezia), Prof. J. van der Vecht (Putten, Netherlands), Dr. J. Gusenleitner (Linz), Dr. N. V. Kurzenko (Institute of Biology and Pedology, Vladivostok) and Dr. J. M. Carpenter (Harvard Univ.) who provided me with valuable specimens for comparison and useful suggestions. Dr. Giordani Soika, in particular, kindly determined *Ancistrocerus* specimens for me.

The following entomologists much helped me in providing valuable materials, useful information and suggestions: Shigeyuki Aoki (Rissho Univ.), Kintarô Baba (Niigata-ken), Toyokazu Fujisawa, Haruo Fukuda (Kagoshima Pref. Mus.), Katsuo Goukon (Tohoku Gakuin Univ.), Yoshito Haneda (Fukui-ken), Shirô Higashi (Kagoshima Univ.), Tôru Inaoka (Asahigawa-shi), Ryôsuke Ishikawa (Tokyo Metropolitan Univ.), Hideo Itami (Shibata-shi), Yosiaki Itô (Nagoya Univ.), Kazuaki Kamijo (Hokkaido Forest Exp. Sta.), Teiji Kifune (Fukuoka Univ.), Jun-ichi Kojima (Ibaraki Univ.), Utako Kurosu (Tokyo Nôkô Univ.), Kanetosi Kusigemati (Kagoshima Univ.), Yoshihisa Kusui (Toyonaka-shi), Shun'ichi Makino (Hokkaido Univ.), Taiji Moriyama (Kagoshima-shi), Tadao Murota (Fukui-ken), Hirohiko Nagase (Kamakura-shi), Akira Nagatomi (Kagoshima Univ.), Kôji Nakamine (Kagoshima-shi), Yasuhiro Nakatani (Nara-ken), Junichi Nakayama (Sapporo-shi), Toshiaki Nambu (Saitama-ken), Masahiro Ôhara (Hokkaido Univ.), Ryohichi Ohgushi (Kanazawa Univ.), Masayuki Ônuma (Jôetsu-shi), Isao Ôtsuka (Kumamoto-shi), Akio Seino (Shibata-shi), Hirohisa Suda (Sakura-shi), Tsukasa Sunose (Urawa Gakuin High School), Yasushi Takai (Seki-shi), Yoshisuke Takeshima (Aomori-ken), Hideo Takahashi (Hachijô-jima), Tadashi Tano (Fukui-ken), Mieko Tatsuno (Yokohama-shi), Mamoru Terayama (Tôhô Women's Senior High School), Kiyonori Tomiyama (Tokyo Metropolitan Univ.), Katsuji Tsuneki (Mishima-shi), Shôji Watahiki, Hirofumi Watanabe (Kagoshima Univ.), Masateru Yamada (Aomori-ken), Kazuki Yamamuro (Tôkyô-to), Sôichi Yamane (Ibaraki Univ.), Seiei Yamauchi (Okinawa-ken) and Junichi Yukawa (Kagoshima Univ.).

Last but not least I thank Dr. Nobumitsu Kawakubo (Kagoshima Univ.) for his kind help in editing the final draft of the manuscript.

II. MATERIALS AND SURVEY AREAS

The present study is mainly based upon my collection now at the Department of Biology, Faculty of Science, Kagoshima University. The main part of the collection will finally be deposited in the collection of the Entomological Institute, Faculty of Agriculture, Hokkaido University. I have examined many valuable specimens preserved in the following collections: the Iwata collection in the Entomological Laboratory, Faculty of Agriculture, Kobe University, the Tano collection (Fukui-ken), the Ikudome collection, Kagoshima Women's Junior College, the collection of the Entomological Institute, Hokkaido University, and the collections of the Entomological Laboratory, Faculty of Agriculture, Kyushu University, and University of the Ryukyus.

The names of some collectors are abbreviated as follows: AN (A. Nagatomi), HI (H. Itami), KB (K. Baba), KT (K. Tomiyama), SI (S. Ikudome), SKY (Seiki Yamane), SY (Sôichi Yamane), TM (T. Murota), TN (T. Nambu), TT (T. Tano), YH (Y. Haneda), YM (Y. Maeta).

The present study covers the regions mentioned below. Honshû, Shikoku and Kyûshû together are called Japan proper, and these three islands and Hokkaidô together the Japanese mainlands (Figs. 1,2). The Japanese suffix -jima, -shima or -tô usually but not always means an island or islet. The suffixes -shotô, -guntô and -rettô, which are applied to archipelagos and island groups, are not used in this paper: for example, "Yaeyama-shotô" is constantly replaced by the Yaeyama Islands or the Yaeyama group. Other suffixes used are -ken, -to and -fu, all for prefectures.

1. *Hokkaidô* (= Ezo, Yezo). 78,073 km² in area. Sapporo and its vicinity have most intensively been surveyed. In other parts, especially northern and eastern parts, the eumenid fauna is still only poorly known.

2. *Islands close to Hokkaidô*. Munakata and S. Yamane (1970) studied vespid wasps of Okushiri-tô (143 km²), and Munakata (1987) recorded two eumenid species from the island. Other islands remain almost wholly unsurveyed. I have examined two species of *Ancistrocerus* from Rebun-tô (83 km²) located close to Wakkanai, the northernmost city in Japan.

3. *Honshû*. The largest island of Japan, 227,414 km² in area. Some entomologists, including non-professional, have accumulated eumenid collections in the following regions: Aomori-ken (Yamada, 1983), Miyagi-ken (Goukon, 1983a,b), Niigata-ken (K. Baba, A. Seino; see Yamane, 1982b), Chiba-ken (Suda, 1979), Saitama-ken (Nambu, 1978), Ibaraki-ken (Hisamatsu et al., 1986), Nagano-ken (Y. Maeta), Fukui-ken (Haneda et al., 1985), Kansai District (K. Iwata; Sato, 1963a,b, 1964), and Shimane-ken (Y. Maeta). They reported local faunas in journals or have sent me representative specimens.

4. *Sado-ga-shima and Awa-shima* (Niigata-ken). These islands in the Japan Sea were surveyed by members of the Essa Entomological Society, especially by Dr. K. Baba and Mr. A. Seino. The eumenid fauna of Sado-ga-shima (857 km²) is relatively well known (Yamane, 1982b), whereas at present no information is available for Awa-shima (9.1 km²).

5. *Izu Islands* (Tôkyô-to). This island group is located south of the Kantô District between 34°45'N and 29°25'N in the Pacific Ocean, and consists of some ten islets, of which Izu-ôshima is the largest (90.99 km²) (Fig. 3B). There are brief papers reporting insect faunas of these islands, but no complete list of aculeates is available. I have examined some eumenid specimens through the courtesy of Prof. Y. Hirashima and Mr. H. Takahashi.

6. *Nanatsu-jima Islands* (Ishikawa-ken). Located in the Japan Sea just north of the Noto

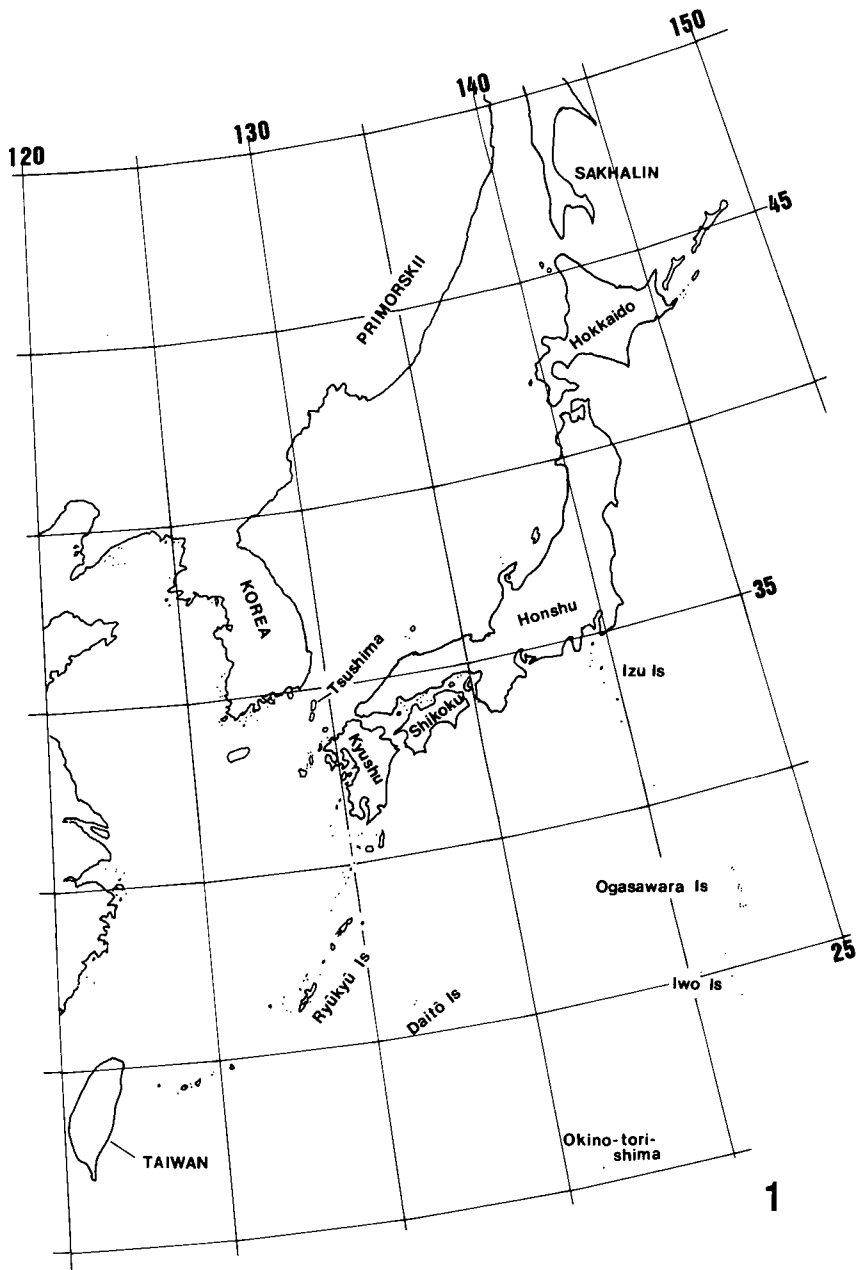

Fig. 1. Japan and adjacent regions.

Peninsula. The largest islet (Hegura-jima) is 1.03 km² in area, and all the other islets of the Nanatsu-jima group are less than 0.15 km². The wasp fauna of these islands was studied by Ohgushi and Tokumoto (1986). I have examined the material used by them.

7. *Oki Islands* (Shimane-ken). This island group lies to the north of the Shimane Peninsula in the Japan Sea, and comprises four main islands (13.64-244.31 km²) and many minute ones. I have examined a few eumenid specimens preserved in the collection of Shimane University through the courtesy of Dr. Y. Maeta.

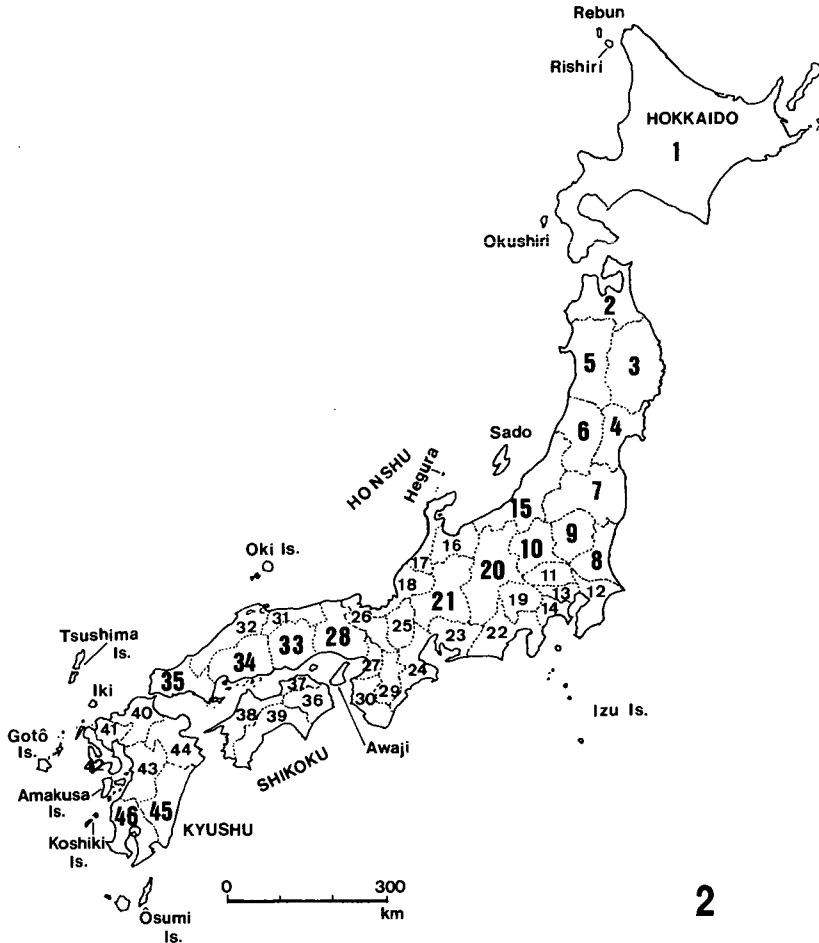

Fig. 2. Japanese mainlands and some associated islands. 1, Hokkaidô; 2, Aomori-ken; 3, Iwate-ken; 4, Miyagi-ken; 5, Akita-ken; 6, Yamagata-ken; 7, Fukushima-ken; 8, Ibaraki-ken; 9, Tochigi-ken; 10, Gumma-ken; 11, Saitama-ken; 12, Chiba-ken; 13, Tôkyô-to; 14, Kanagawa-ken; 15, Niigata-ken; 16, Toyama-ken; 17, Ishikawa-ken; 18, Fukui-ken; 19, Yamanashi-ken; 20, Nagano-ken; 21, Gifu-ken; 22, Shizuoka-ken; 23, Aichi-ken; 24, Mie-ken; 25, Shiga-ken; 26, Kyôto-fu; 27, Ôsaka-fu; 28, Hyôgo-ken; 29, Nara-ken; 30, Wakayama-ken; 31, Tottori-ken; 32, Shimane-ken; 33, Okayama-ken; 34, Hiroshima-ken; 35, Yamaguchi-ken; 36, Tokushima-ken; 37, Kagawa-ken; 38, Ehime-ken; 39, Kôchi-ken; 40, Fukuoka-ken; 41, Saga-ken; 42, Nagasaki-ken; 43, Kumamoto-ken; 44, Ôita-ken; 45, Miyazaki-ken; 46, Kagoshima-ken.

8. *Other islands close to Honshū*. Most of these islands remain unsurveyed for the eumenid fauna. Iwata's collection (Kobe University) contains some specimens from Awajishima (593 km²) located between Honshū and Shikoku. Okada (1981) recorded two species of Eumenidae in the southern parts of this island. Yuki (1936) listed five eumenid species from Iwai-jima (7.5 km²), an island in the Setonaikai Sea, where lie numerous islands.

9. *Shikoku*. 18,256 km² in area. I have examined many specimens collected by Mr. Y. Sugihara and Dr. S. Ikudome mainly in Kōchi-ken. Their materials may well represent the eumenid fauna of this island (Ikudome & Yamane, 1983). None of the islets located near Shikoku has yet been surveyed for eumenids.

10. *Kyūshū*. 36,554 km² in area. The following regions have been more or less intensively surveyed: Fukuoka-ken (K. Yasumatsu), Nagasaki-ken (R. Ohgushi), Kumamoto-ken (Ôtsuka, 1984), and Kagoshima-ken (Nagase, 1981, 1982).

11. *Tsushima Islands* (Nagasaki-ken). This interesting island group, located between Korea and Kyūshū, has been paid special attention by biogeographers. Collections have been made mainly on two large islands (Kami-agata, 253 km²; Shimo-agata, 445 km²), and most of the numerous minute ones remain unsurveyed. Shirōzu and Miyata (1976) compiled a list of insects recorded. Through the courtesy of Dr. Y. Miyatake I could examine the eumenid specimens mainly collected by the late Mr. Isamu Hiura and preserved in the collection of the Osaka City Museum of Natural History. Mr. A. Seino and Mr. K. Nakamine provided me with some interesting additional materials.

12. *Gotō Islands* (Nagasaki-ken). This island group lies in the west of northern

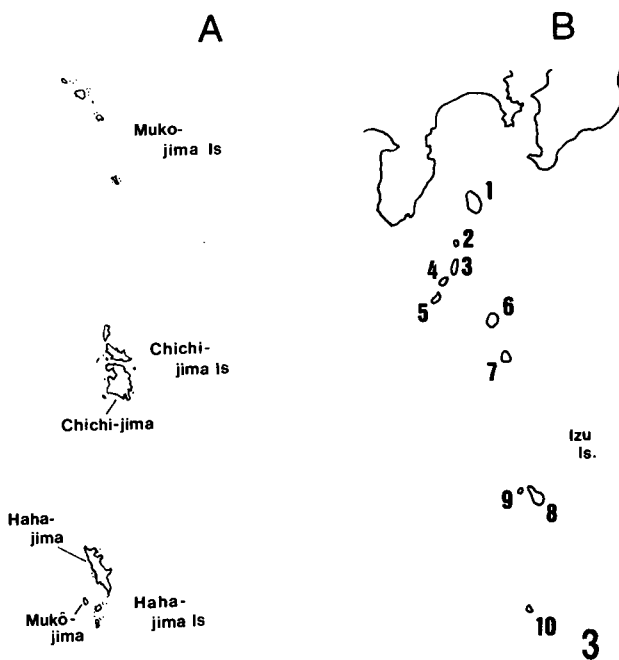

Fig. 3. Ogasawara (Bonin) Islands (A) and Izu Islands (B). 1, Izu-ōshima; 2, To-shima; 3, Nii-jima; 4, Shikine-jima; 5, Kōzu-jima; 6, Miyake-jima; 7, Mikura-jima; 8, Hachijō-jima; 9, Hachijō-kojima; 10, Ao-ga-shima.

Kyūshū, and comprises numerous islands. Ejima et al. (1981) recorded four species of Eumenidae. Mr. J. Nakayama sent me some specimens collected by him. However, most of the islands of this archipelago remain unsurveyed.

13. *Other Islands close to Kyūshū*. Miyata et al. (1977) recorded four eumenid species from Oki-no-shima (Fukuoka-ken) located in the Genkai-nada and at 77 km from Fukuoka-shi. There are numerous islands belonging to Nagasaki-ken, most of which have not been surveyed for the eumenid fauna. I have examined only a few specimens from the Amakusa Islands (Kumamoto-ken), the Naga-shima Islands (Kagoshima-ken), the Koshiki-jima Islands (Kagoshima-ken), and Akune-ōshima (Kagoshima-ken). No information is available about the eumenid fauna of the islets close to Ōita-ken and Miyazaki-ken.

14. *Ryūkyū Islands* (Kagoshima-ken & Okinawa-ken). There are more than 200 islands between the Kyūshū mainland and Taiwan (Fig. 4; most of the small islets are omitted). These islands, including the Daitō and Senkaku groups, are called the Nansei Islands (Nansei-shotō; South-western Islands). The Ryūkyū Islands here defined are those islands that lie between Kyūshū and Taiwan, excluding the Daitō and Senkaku Islands. Synonyms are the Ryukyus, the Ryūkyū-rettō, the Ryūkyū Archipelago and the Ryūkyū Curve. In older literature Ryūkyū was often spelled as "Liukiu", "Loochoo", or "Riukiu". This long archipelago (ca. 1200 km from north to south) comprises many island groups and subgroups for which various nomenclatorial systems have been applied. In this paper I use a slightly modified version of the system proposed by Mezaki (1980, 1983). Island groups and main islands belonging to them are listed below (for island areas, see Discussions on geographical distribution):

A. *Northern Ryukyus* (Kagoshima-ken)

Uji Islands: Ie-jima (= Iye-jima), Mukai-jima

Kusagaki Islands: Kami-no-shima, Shimo-no-shima

Mi-shima Islands (= Kuchi-no-mishima Is.): Take-shima, Iō-jima (= Iwo-jima, Kikai-ga-shima), Kuro-shima

Ōsumi Islands: Tane-ga-shima, Mage-shima, Yaku-shima, Kuchinoerabu-jima

Northern islets of Tokara Islands (Linshoten Is.): Kuchi-no-shima, Naka-no-shima, Gaja-jima, Taira-jima, Suwanose-jima, Akuseki-jima

B. *Central Ryukyus*

Southern islets of Tokara Islands (Kagoshima-ken): Takara-jima, Kodakara-jima

Amami Islands (Kagoshima-ken): Amami-ōshima (= Ōshima), Kikai-jima, Kakeroma-jima, Uke-shima, Yoro-shima, Tokuno-shima, Okinoerabu-jima (= Okierabu-jima), Yoron-tō (Yoron-jima)

Okinawa Islands (Okinawa-ken): Iheya-jima, Izena-jima, Okinawa-jima (= Okinawa-hontō), Kouri-jima, Yagaji-jima, Sezoko-jima (= Sesoko-jima), Yokatsu group (Ike-shima, Miyagi-jima, Yabuchi-jima, Hamahiga-jima, Tsuken-jima, Henza-jima), Kudaka-jima, Kerama group (Mae-shima, Tokashiki-jima, Zamami-jima, Aka-shima, Kuba-jima), Aguni-jima, Kume-jima

C. *Southern Ryukyus* (= Saki-shima Islands) (Okinawa-ken)

Miyako Islands: Miyako-jima, Ikema-jima, Kurima-jima, Irabu-jima, Shimoji-jima

Tarama Islands: Tarama-jima, Minna-jima

Yaeyama Islands (= Yayeyama Is.): Ishigaki-jima, Taketomi-jima, Kuro-shima, Kayama-jima, Kohama-jima (= Kobama-jima), Iriomote-jima, Yubu-jima, Hatoma-jima, Uchibanare-jima, Sotobanare-jima, Hateruma-jima, Yonaguni-jima (= Yonakuni-jima)

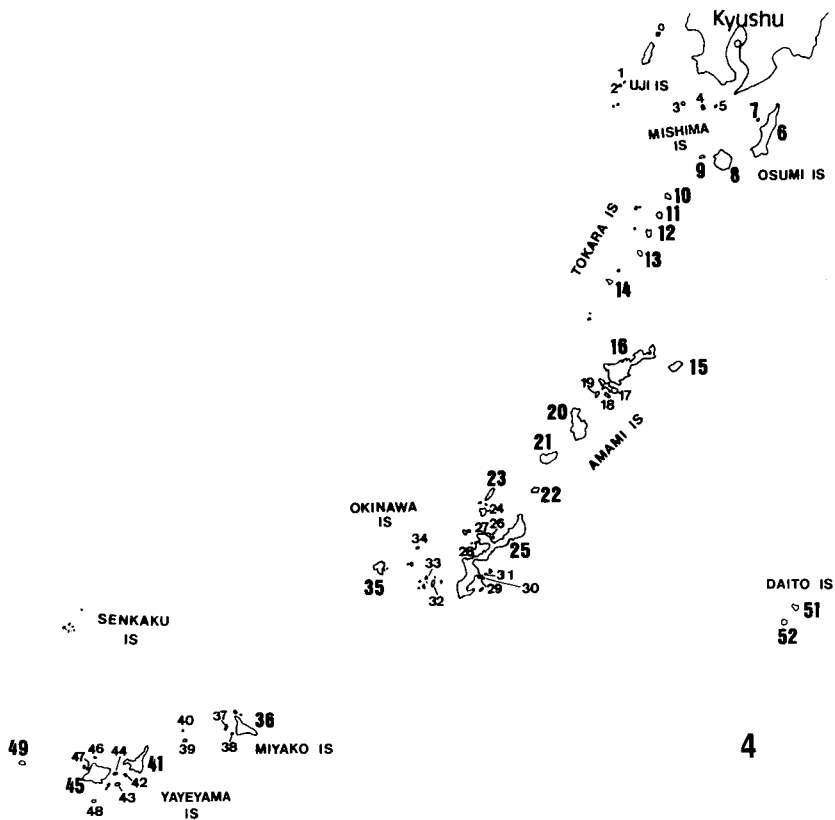

Fig. 4. Nansei Islands, comprising Ryūkyū Is., Daitō Is. and Senkaku Is. Most of the small islets are omitted. 1, Ie-jima; 2, Mukai-jima; 3, Kuro-shima; 4, Iō-jima; 5, Take-shima; 6, Tane-ga-shima; 7, Mage-shima; 8, Yaku-shima; 9, Kuchinoerabu-jima; 10, Kuchi-no-shima; 11, Naka-no-shima; 12, Suwanose-jima; 13, Akuseki-jima; 14, Takara-jima; 15, Kikai-jima; 16, Amami-ōshima; 17, Kakeroma-jima; 18, Uke-shima; 19, Yoro-shima; 20, Tokuno-shima; 21, Okinoerabu-jima; 22, Yoron-tō; 23, Iheya-jima; 24, Izena-jima; 25, Okinawa-jima; 26, Kouri-jima; 27, Yagaji-jima; 28, Sezoko-jima; 29, Yabuchi-jima; 30, Hamahiga-jima; 31, Miyagi-jima; 32, Tokashiki-jima; 33, Zamami-jima; 34, Aguni-jima; 35, Kume-jima; 36, Miyako-jima; 37, Irabu-jima; 38, Kurima-jima; 39, Tarama-jima; 40, Minna-jima; 41, Ishigaki-jima; 42, Taketomi-jima; 43, Kuro-shima; 44, Kohama-jima; 45, Iriomote-jima; 46, Hatoma-jima; 47, Uchibanare-jima; 48, Hateruma-jima; 49, Yonaguni-jima.

Intensive collections of insects have been made by Prof. S. Azuma and Mr. M. Kinjo of the University of the Ryukyus, but their efforts have been restricted to a small number of relatively large islands in Okinawa-ken. Recently, more than 50 islands have been surveyed for the aculeate fauna by me and some other biologists (e.g., S. Ikudome, C. Nozaka, T. Murota, K. Tomiyama, K. Nakamine, and Y. Kusui). Literature on the vespoid fauna of the Ryukyus will be cited in Distribution pattern. The following islands remain almost wholly unsurveyed: uninhabited islets of the Tokara group such as Gaja-jima,

Kogaja-jima and Yokoate-jima, islets around Kakeroma-jima (Amami group) such as Sukomobanare-jima and Eniyabanare-jima, many of the islets of the Okinawa group, and some islets in the Southern Ryukyus such as Ôgami-jima (Miyako group), Aragusuku group, and Nakanougan-jima (Yaeyama group).

15. *Senkaku Islands* (Okinawa-ken). This island group is located to the north of the Yaeyama group and consists of four islets (0.30-3.82 km²) and some rocks. Takara (1954) and Ikehara and Shimojana (1971) reported the terrestrial animal fauna of this island group, but their lists include no vespoid species.

16. *Daitô Islands* (= Oagari Is.) (Okinawa-ken). The Daitô group comprises the following isolated islands: Kitadaitô-jima (= Kitaoagari-jima, North Borodino I., 12.58 km²), Minamidaitô-jima (= Minamioagari-jima, South Borodino I., 30.59 km²), and Okidaitô-jima (= Okioagari-jima, Rasa I., 1.19 km²). It is separated from the islands of the Ryukyus by the Ryûkyû Trench (maximum depth: 7481 m) (Hanzawa, 1935). I have examined eumenid specimens collected by Dr. S. Ikudome on Kita- and Minamidaitô-jima in 1987.

17. *Ogasawara Islands* (= Bonin Is.) (Tôkyô-to). The Ogasawara group is volcanic in origin (oceanic islands), and comprises three subgroups (Fig. 3A) and three isolated islets. Aculeate fauna has been studied on a few larger islets (Chichi-jima, 23.9 km², & Haha-jima, 21.2 km²). Nakane (1970) listed the insects known at that time, including three eumenid species. I have examined some eumenids collected by several entomologists on these two islets.

III. FAMILY EUMENIDAE (POTTER WASPS)

1. Taxonomy

The Vespoidea are often called Diploptera because of the longitudinal folding of their fore wings at rest, though this characteristic is absent in some groups and is not regarded as part of the ground-plan of the Vespoidea (Carpenter, 1982). The outstanding autapomorphies are the elongate 1st discoidal cell (discal cell in Carpenter, 1982) which is at least the equal of submedian cell, spined parameres of male genitalia, and oviposition prior to provisioning (Carpenter, 1982).

The classification system proposed by Richards (1962) for the superfamily Vespoidea has long been accepted by most of vespidologists. He recognized three subfamilies in the family Eumenidae, viz., Raphiglossinae, Discoeliinae, and Eumeninae. Among them the unnaturalness of the Discoeliinae (= Zethinae of Carpenter) was previously recognized to some extent by Bohart and Stange (1965), and Carpenter (1982) conclusively showed the paraphyly of the group. According to Carpenter the Raphiglossinae perhaps form a monophyletic group, but do not merit taxonomic recognition, since a group composed of the Eumeninae and Zethinae and lacking the Raphiglossinae is unnatural. He recognized only one family (Vespidae) in the Vespoidea, and reduced the traditional Eumenidae to a subfamily (Eumeninae) comprising the traditional Raphiglossinae, Zethinae, and Eumeninae. His taxon Eumeninae is characterized by the following derived character conditions:

Mandible : clypeus ratio 0.78-2.00; occipital carina forked, with a branch running to the mandibular base and one running toward the hypostoma (either branch, and usually the hypostomal, may be secondarily lost); parategula present; hind coxa with dorsal

carina; claws bifid; basal ring of male genitalia short, encompassing bases of parameres; volsella with digitus, a broad pincerlike lobe; cuspis being a reduced scalelike lobe attached mesally to parameres; larval labrum as wide as clypeus and narrowed where these join, dorsally bisinuate and ventrally bilobed.

I agree with Carpenter in his view that at present no formal taxonomic recognition should be made at suprageneric levels, because there has been made no detailed phylogenetic analysis of the genera. However, in this paper Richards' view is adopted and the eumenids are treated as a family, because I do not necessarily agree with the view held by Carpenter that the classification system should be isometric with the cladogram.

Among the Japanese Vespoidea, the Eumenidae are readily distinguished from the Vespidae (Japan is lacking in Masaridae) by the bifid claws, the presence of parategula (process of mesoscutum sensu Richards), and the long mandibles usually crossing each other.

Approximately 180 genera are currently recognized in the Eumenidae (Carpenter, 1986). No reliable figure is available for the number of world species of this large and diverse group. Bequaert (1918) presented the following figures for various zoogeographical regions: 349 species in the Palearctic, 225 in the Nearctic, 369 in the Ethiopian, 549 in the Oriental and Australian, 607 in the Neotropical regions. Vecht and Fischer (1972) recognized 702 Palearctic species in 56 genera; this figure is twice as big as that given by Bequaert (1918) for the same region. According to Krombein (1979) 266 species in 23 genera occur in the Nearctic region. Taylor et al. (1985) listed more than 300 described Australian species in 35 genera, many of them being endemic. Judging from these figures the number of the world species may amount to 2500-3500. In Japan 54 species are known to occur (this study).

Table 1. Chromosome numbers in Eumenidae*.

<i>Ancistrocerus japonicus</i>	Honshû, Jpn	n = 12
<i>Stenodynerus tokyanus</i> ¹⁾	ditto	n = 18
<i>Allodynerus mandschuricus</i> ²⁾	ditto	n = 8
<i>Euodynerus nipanicus</i> ³⁾	ditto	n = 5
<i>Euod. foraminatus</i>	Calif., USA	n = 8
<i>Rhynchium quinquecinctum</i> ⁴⁾	Iriomote I., Jpn	n = 15
	Amami I., Jpn	n = 15
<i>Anterhynchium flavomarginatum</i>	Honshû, Jpn	n = 6
<i>Orancistrocerus dreusenii</i>	ditto	n = 14
<i>Ancistrocerus adiabatatus</i>	Calif., USA	n = 6
<i>A. spilogaster</i>	ditto	n = 6
<i>A. simulator</i>	ditto	n = 7
<i>A. tuberculiceps</i>	ditto	n = 10
<i>Symmorphus apiciornatus</i> ⁵⁾	Honshû, Jpn	n = 4
<i>S. foveolatus</i> ⁶⁾	ditto	n = 5

* Cited from Goodpasture (1974) for the N. American species, and from Nakatani (1988) for the Japanese ones. In Nakatani, the species 1) - 6) in this list are inadequately referred to as: 1) *Stenodynerus* sp., 2) *Stenodynerus frauenfeldi*, 3) *Euodynerus notatus*, 4) *Rhynchium fukaii*, 5) *Symmorphus* sp., and 6) *S. captivus*.

Karyological studies were made for some Nearctic and Japanese species by Goodpasture (1974) and Nakatani (1988). Five out of the nine species studied by Nakatani were unidentified or misidentified; corrected names for them are given in Table 1.

2. Biology

The Eumenidae are solitary wasps with some exceptions, in which female's caring for the larvae (subsocial behavior) is observed. Among the subsocial species are *Synagris* spp. (Bequaert, 1918), *Calligaster cyanopterus* (Williams, 1919), *Antepipona tropicalis* (Iwata, 1971), *Orancistrocerus drewseni* (Iwata, 1972; Itino, 1980), *Pararrhynchium ornatum ornatum* (Iwata, 1938a, 1983, pp. 108-109), *Paraleptomenes mephitis* (Krombein, 1978), some species of *Zethus* (Bohart & Stange, 1965), and probably *Oreumenes decoratus* (Tsuneki, 1980). Progressive provisioning characterizes these subsocial species (Eickwort, 1981). The Japanese population of the subsocial *O. drewseni* is very probably parthenogenetic, since no males have been found in both field-captured adult and nest samples, while the Korean and Taiwanese populations are biparental.

The eumenids build their nests at least partially with mud or plastic materials from plants. Many of them use pre-existing hollow cavities for nests (tube-renters), some others build their nests (often mud pots) above ground not using pre-existing tubes or holes

Table 2. Nesting types in the Japanese Eumenidae. The Japanese fauna lacks burrowers.

Tube-renters	Mud-daubers
<i>Discoelius japonicus</i> **	<i>Orancistrocerus drewseni</i> *
<i>Stenodynerus frauenfeldi</i>	<i>Ancistrocerus japonicus</i> *
<i>Allodynerus delphinalis</i>	<i>A. melanocerus</i>
<i>A. mandschuricus</i>	<i>A. oviiventris</i> ***
<i>Euodynerus dantici</i>	<i>Eumenes rubronotatus</i>
<i>Euod. nipanicus</i>	<i>Oreumenes decoratus</i> *
<i>Euod. trilobus</i> ***	<i>Delta esuriens</i>
<i>Rhynchium quinquecinctum</i>	<i>Delta flavopictum</i> *
<i>Anterhynchium flavomarginatum</i>	
<i>Pararrhynchium ornatum</i>	
<i>Orancistrocerus drewseni</i> *	
<i>Ancistrocerus japonicus</i> *	Potter wasps
<i>A. trifasciatus</i>	<i>Eumenes fraterculus</i>
<i>A. parietinus</i> ***	<i>E. rubrofemoratus</i>
<i>A. nigricornis</i> ***	<i>E. micado</i>
<i>A. antilope</i> ***	<i>Oreumenes decoratus</i> *
<i>Symmorphus foveolatus</i>	<i>Delta flavopictum</i> *
<i>S. decens</i>	
<i>S. apiciornatus</i>	
<i>S. mutinensis</i>	
<i>S. cliens</i>	
<i>Pseumenes depressus</i> ***	
" <i>Pachymenes</i> " <i>yaeyamensis</i>	

* Species with two nesting types.

** Species constructing cell partitions made of plant leaves.

*** Observed in Taiwan, China, or Europe by various authors.

(mud-daubers and potter wasps), and still others, not represented in Japan, dig either in clayey ground or in walls (burrowers)(cf. Iwata, 1971; Spradbery, 1973) (Table 2). Mud-daubers construct their nests on stones or walls of houses; the nests are broadly attached to the substrates and not complete pots. The true potter wasps construct their pot nests on plant stems, etc. These two types are, however, sometimes not clearly distinguished. The burrowers often make a chimney at the exit of the burrows with mud paste. The nesting proceeds in the order: cell building - oviposition - hunting, with the only exception of the Oriental genus *Pseumenes* in which the hunting is said to precede oviposition (Piel, 1935). In general female wasps hunt larvae of various lepidopteran families for their larvae. Wasps of *Raphiglossa*, *Psiloglossa* and *Symmorphus* hunt for coleopteran larvae.

Biology of tube-nesting Eumenidae in the USA was intensively studied by Krombein (1967). Spradbery (1973) reviewed the natural history of eumenids, based mainly upon British species. The comparative behavior of the eumenid wasps is reviewed by Iwata (1942, 1971, 1982), Malyshev (1968), Evans and West-Eberhard (1970), and Kurzenko (1980).

3. Eumenids as natural enemies of pests

The members of the family Eumenidae are predatory wasps and provide their nests with caterpillars or other insect larvae. Therefore, they are at least potentially beneficial in agriculture and forestry. However, in most countries of the world, they have not positively been used as natural enemies of agricultural pests.

Some common Japanese species hunt for the mature larvae of leaf-rolling microlepidopterans of the families Tortricidae, Pyralidae and Gelechiidae. Among them *Anterhynchium flavomarginatum micado* and *Rhynchium quinquecinctum fukaii* prefer pyralid larvae, while *Euodynerus nipanicus* (*Odynerus quadrifasciatus* sensu Iwata) predaes chiefly on Tortricidae. Mr. Yoshisuke Takeshima, a devoted farmer in Aomori-ken (northern Honshû), set reed tubes for three eumenid species, *A. flavomarginatum*, *Euod. nipanicus* and *Discoelius japonicus*, that were commonly seen in his apple orchard where damage by tortricid larvae was serious. These tortricids (mainly *Adoxophyes orana*) not only feed on young leaves that are rolled by them, but often damage the surface of the fruit itself. Of the three eumenid species, *Euod. nipanicus* increased in number, and in 1970 the number of tortricid larvae transported to nests of this species was estimated at 92,700 in the orchard (ca. 1 hectare). The damage to the fruit was less extensive in the area provided with trap nests than in the control. Unfortunately, his method has not been developed thereafter, presumably because the management of wasps and timing of sprinkling insecticides are burdensome.

In China, vespine and polistine wasps have been used to control agricultural pests (caterpillars) (Lee, 1982, Lee et al., 1986). Lee et al. (1975) studied the biology of a subtropical eumenid, *Rhynchium quinquecinctum* (*R. brunneum*), that predaes on lepidopterous pests in cotton and rice fields. They stated that in Zhenghai County one female wasp captured 90-180 caterpillars per day. But the activity of this wasp did not necessarily cover the effective time for controlling insect pests. Since this eumenid is comparatively not vulnerable to pesticides, it is possible to use it together with the latter (Lee et al., 1984). However, in general, the effectiveness of eumenid wasps as indigenous biotic factors against pest insects is at present not accurately evaluated.

IV. CHARACTERS AND THEIR CONDITIONS

Numerous characters have been used in vespid taxonomy and systematics. Important characters are discussed in Bequaert (1918), Richards (1962) and others. Carpenter and Cumming (1985) made a character analysis of the Nearctic Eumenidae, and Nakamine (1987) discussed the polarity for characters with the Japanese species and genera of Eumenidae. In this paper no attempt will be made to determine the polarity (ancestral *vs.* derived). The characters of taxonomic importance used in this paper are listed below with their observed conditions (states). No detailed study has been made on the male genitalia. Here Yamane's (1982) and Nakamine's (1987) results are particularly consulted, and only Japanese genera and species are referred to.

Head

Mandibular shape. The mandibles are relatively short and not crossing each other (*Discoelius*, Fig. 20), or longer and decussate (other genera, e.g., Figs. 6, 337).

Cephalic fovea (Fig. 5, *cef*). There are often a pair of small pits (foveae) set in a slight depression (*da*) on the female vertex near its occipital margin. The condition of the depressed area and the distance between the pits vary according to genera and sometimes even between congeneric species. Sometimes the depressed area bears only one pit, and in several genera (*Discoelius*, *Pseumenes*, *Oreumenes*, *Eumenes*, *Delta*, and "*Pachymenes*") it bears no pits. The state of the cephalic foveae is discussed at length by Cumming and Leggett (1985).

Clypeal shape. Clypeus is higher than wide in many genera, while wider than high in others such as *Discoelius*, *Symmorphus* and *Allodynerus* (Figs. 20, 62). It is apically emarginate variously, and often more pronouncedly in the male.

Palpi. Maxillae and labium bear palpi. The number of segments is usually 6 in maxillary and 4 in labial palpi (Fig. 7), but reduced in some forms and most commonly to 5 and 3 (5 : 3 according to the palpal formula proposed by Carpenter & Cumming, 1985). Among the Japanese genera this condition is seen only in *Okinawepipona* (Fig. 8; Nakamine, 1987).

Terminal segment of male antenna. Usually the terminal (13th) segment of the male antenna is recurved to form a hook. Only in *Symmorphus* and *Oreumenes* it is of normal shape (but abnormal among the Eumenidae)(Figs. 236-245, 290). The size of the hook and modification of segments that receive the hook are of taxonomic importance.

Alitrunk (mesosoma: thorax + propodeum)

Pits and punctures on the anterior face of pronotum. The anterior vertical face of pronotum is generally smooth, shining, without hairs, but in some groups it has pits, punctures or striae. For example, in *Stenodynerus* the area has a pair of median pits in lower part, and some transverse striae just above the pits (Fig. 13). In "*Pachymenes*" the striae are deep (Fig. 14). Distinct punctures are found in lateral parts of the area in *Euodynerus*, "*Pachymenes*" and some species of *Stenodynerus*.

Pronotal carina (Figs. 9, 10). The presence of a pronotal carina constitutes part of the ground-plan of the Eumenidae (Carpenter & Cumming, 1985). The carina is generally complete, and often forms a translucent lamella. In *Delta flavopictum* it is wholly lost, and in some genera such as *Ancistrocerus* and *Stenodynerus* medially (dorsally) interrupted. It is not interrupted but reduced in height in the middle in *Okinawepipona*, *Euodynerus* and

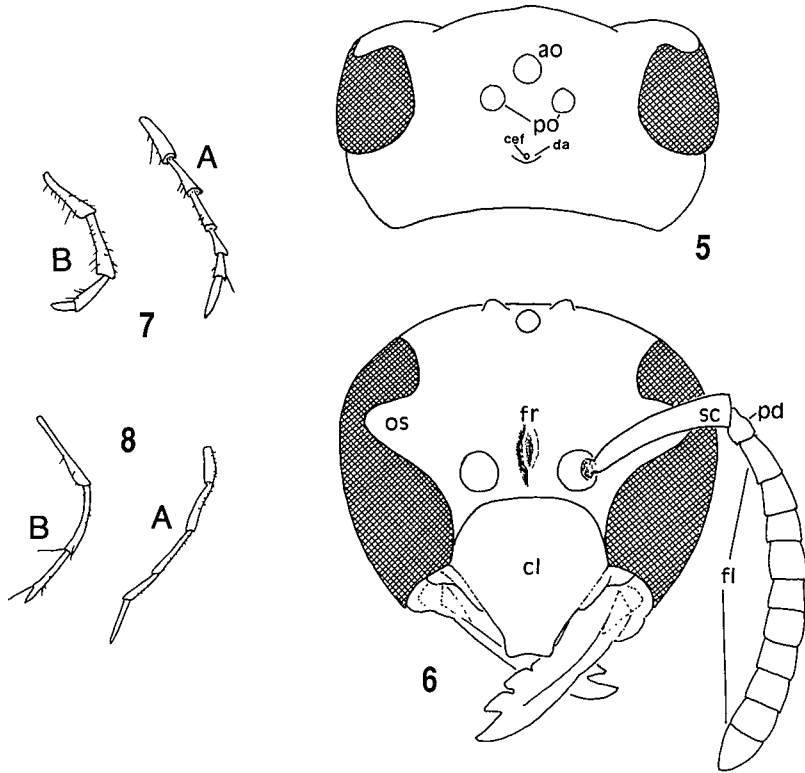

Figs. 5-8. Head of Eumenidae. 5,6, *Stenodynerus ogasawaraensis*. *ao*, anterior ocellus; *cef*, cephalic fovea; *cl*, clypeus; *da*, depression for fovea; *fl*, antennal flagellum; *fr*, frons; *os*, ocular sinus; *pd*, pedicel; *po*, posterior ocelli; *sc*, scape. 7, 8, maxillary (A) and labial (B) palps of *S. ogasawaraensis* (7) and *Okinawepipona kogimai* (8).

Allodynerus (Nakamine, 1987).

Pretegular carina (Fig. 10). The pronotal lobe (*pl*) is usually defined anteriorly by a distinct carina (*pc*). It is found in most Japanese genera, but absent in *Eumenes*.

Epicnemial carina (Fig. 10). This carina (*ec*), separating epicnemium (*ep*) from the rest of mesepisternum and commonly seen among eumenid genera, is absent in *Ancistrocerus*, *Pseumenes*, *Oreumenes*, *Eumenes*, *Delta*, and *Symmorphus foveolatus*.

Pleural and epipleural sutures (Fig. 10). Pleural suture (or sulcus, *ps*) divides the mesopleuron into an anterior mesepisternum and posterior mesepimeron (*me*). Epipleural suture (*es*) (= ? dorsal mesepisternal groove of Richards, 1973) divides the mesepisternum into dorsal (*dms*) and ventral mesepisternum (*vms*). These sutures vary in condition, from a simple narrow furrow to a rather wide one with many transverse carinae in it. They are evanescent in "*Pachymenes*".

Notaulices (Fig. 9). These (*nt*) are a pair of furrows running on the mesoscutum (*msc*) from near its posterior margin forward. Carpenter and Cumming (1985) states that this character seems to be useful only at the specific level. Among Japanese genera, notaulices are well developed in *Discoelius* and *Symmorphus*, and incomplete (seen only in posterior part) in *Pseudozumia*, *Orancistrocerus* and *Pararrhynchium*. They may be called "prescutal"

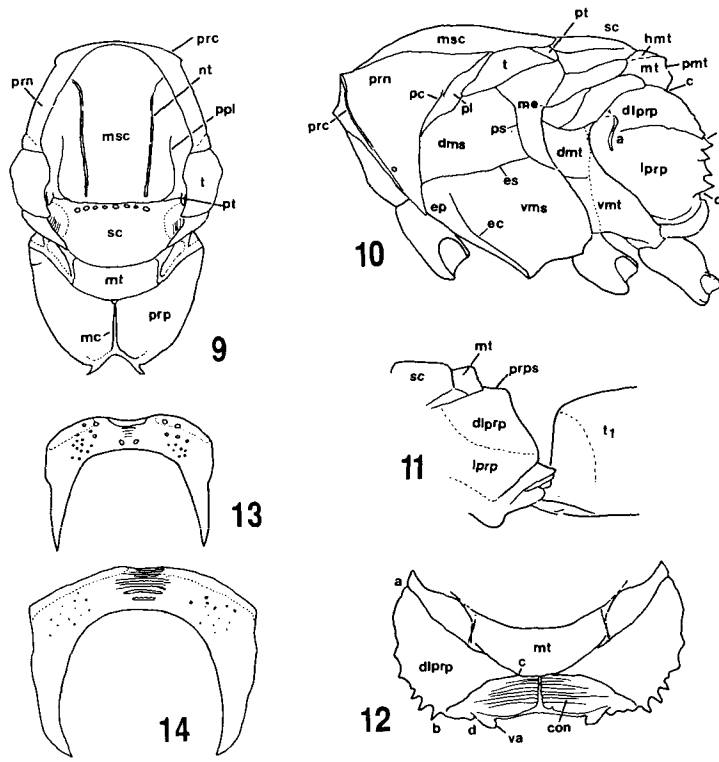

Figs. 9-14. Alitrunk of Eumenidae. 9, *Discoelius japonicus* (♀), from above (after Nakamine, 1987); 10, *Rhynchium marginellum*, profile (after Bequaert, 1918); 11, *Stenodynerus chinensis*, profile (original); 12, Posterior portion of alitrunk of *Rhynchium aestuans*, from above (after Bequaert, 1918); 13, 14, anterior vertical face of pronotum in *Stenodynerus frauenfeldi* (13) (after Yamane, 1979) and "*Pachymenes*" *yayeyamensis* (14) (after Nakamine, 1987).

con, propodeal concavity; *dlprp*, dorsolateral part of propodeum; *dms*, dorsal mesepisternum; *dmt*, dorsal metapleuron; *ec*, epicnemial carina; *ep*, epicnemium; *es*, epipleural suture; *hmt*, horizontal part of metanotum; *lprp*, lateral portion of propodeum; *mc*, median carina; *me*, mesepimeron; *msc*, mesoscutum; *mt*, metanotum; *nt*, notaulix; *pc*, pretegular carina; *pl*, pronotal lobe; *pmt*, posterior face of metanotum; *ppl*, parapsidal line; *prc*, pronotal carina; *prn*, pronotum; *prp*, propodeum; *prps*, propodeal shelf; *ps*, pleural suture; *pt*, parategula; *sc*, scutellum; *t*, tegula; *va*, propodeal valvula; *vms*, ventral mesepisternum; *vmt*, ventral metapleuron. a-b, lateral ridge; b-c superior ridge; b-d, inferior ridge.

grooves when in the latter condition.

Parapsidal lines (Fig. 9). Most eumenids have a second pair of mesoscutual marks, the parapsidal lines (*ppl*), lateral to the notaulices and extending anteriorly from the posterior margin of mesoscutum (Gauld & Bolton, 1988). These lines are often called parapsidal sulci or furrows, though on some occasions they are not furrows but carinae.

Tegula and parategula (= posttegula, mesoscutal hook) (Figs. 9, 10). Tegula (*t*) is variable in shape and length. In some groups its posterior lobe exceeds the posterior end of parategula (*pt*). The phylogenetic significance of the shape and development of tegula

is unknown, though this character is useful in recognizing the Japanese genera.

Metanotum (Figs. 9, 10). In some genera (*Rhynchium*, *Anterhynchium*, *Euodynerus*), the posterior vertical face (*pmt*) is demarcated from dorsal horizontal part (*hmt*) by an angled edge which is sometimes dentate or spinose (Fig. 79). Metanotum may be depressed medially (lateral parts projecting) in *Pararrhynchium* and *Rhynchium*, or flat in most of the other genera.

Propodeal concavity (Figs. 11, 12). Propodeum (morphologically first abdominal segment) may have a median concavity (propodeal concavity; *con*) on posterior face. There may be a narrow but distinct, horizontal part (called "propodeal shelf" (*prps*) by Carpenter & Cumming, 1985) between metanotum and the concavity (e.g., some species of *Stenodynerus*, and *Symmorphus*). The concavity, sometimes not distinctly concave but rather flat, is divided by a median longitudinal furrow or a carina (the carina is often running in the furrow). The conditions of the furrow and carina considerably vary. *Eumenes* and *Delta* are completely lacking in the carina.

Ridges on propodeum (Figs. 10, 12). The posterior face of propodeum is more or less angled on the lateral border, sometimes forming a ridge or carina; the upper and lower

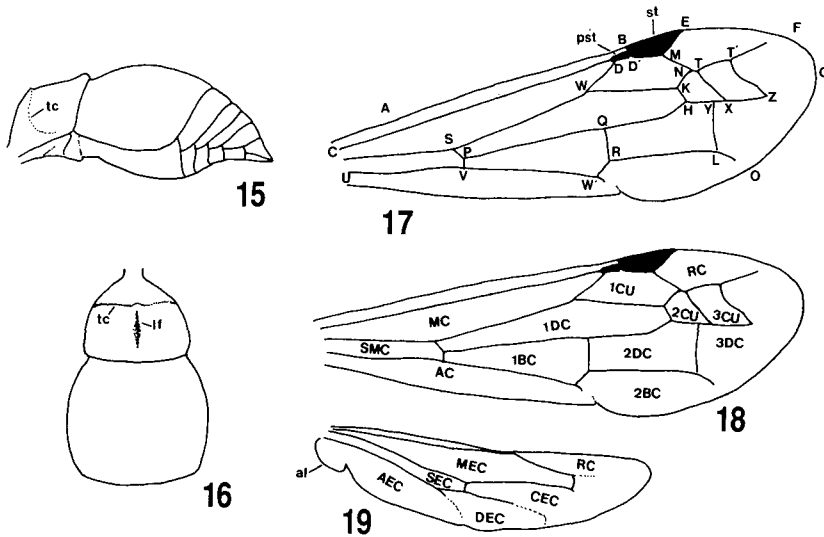

Figs. 15, 16. Gaster of *Symmorphus captivus* (after Nakamine, 1987). *lf*, longitudinal furrow on tergite 2; *tc*, transverse carina.

Figs. 17-19. Wings of *Stenodynerus frauenfeldi*. Systems for veins and cells follow those by Das and Gupta (1989).

Forewing veins. AB, costa; CD, subcosta; EFG, metacarpus; WKHYXZ, cubitus; MNTT'F, radius; MN, abscissa 1 of radius; NT, abscissa 2; T'T', abscissa 3; T'F, abscissa 4; PQRW, discoideus; RLO, subdiscoideus; CS, medius; UV, submedius; VW, brachius; BME, stiga; SWD, basal vein; KN, intercubitus 1; XT, intercubitus 2; ZT', intercubitus 3; QH, recurrent vein 1; YL, recurrent vein 2; PV, nervulus; QRW, postnervulus.

Forewing cells. MC, median; RC, radial; 1CU, 1st cubital; 2CU, 2nd cubital; 3CU, 3rd cubital; SMC, submedian; 1DC, 1st discoidal; 2DC, 2nd discoidal; 3DC, 3rd discoidal; 1BC, 1st branchial; 2BC, 2nd branchial; AC, anal; *pst*, parastigma; *st*, stigma.

Hindwing cells. MEC, mediellan; RC, radiellan; SEC, submediellan; CEC, cubitellan; AEC, anellan; DEC, discoidellan; *al*, anal lobe.

part of the ridge are called the superior (b-c) and inferior ridge (b-d), respectively. The ridge may be toothed or spined. Well-developed ridges are called the propodeal crest, which may bear distinct processes (upper teeth) (Figs. 78, 80; a) just behind the metanotum or propodeal shelf. A ridge extending from the upper end of inferior ridge to the anterolateral corner of propodeum is called lateral ridge (a-b) (Bequaert, 1918).

Apical part of propodeum. Each lateral half of the posterior face of propodeum may be pointed, truncated or deeply emarginate at apex. The apical part bears a long spine in "*Pachymenes*" (Fig. 287).

Mid-tibial spurs. Among the Japanese genera, *Discoelius* has two apical spurs on each mid tibia (Fig. 25), while all the others have only one.

Gaster (metasoma)

In this paper gastral tergites and sternites are often called simply tergites and sternites. Thus, "tergite 1" corresponds to abdominal tergite 2.

Shape of gastral segment 1. Petiolate condition occurs in *Discoelius*, *Oreumenes*, *Eumenes*, *Delta* and *Pseumenes* (eg., Figs. 23, 291, 340). Segment 1 is longer than wide in some *Symmorphus*, and 2/3 as wide as segment 2 in "*Pachymenes*" (Fig. 287). In all the other Japanese genera, it is as wide as segment 2 or only slightly narrower than the latter (usually more than 4/5 as wide as the latter).

Transverse carina on tergite 1 (Figs. 15, 16). The carina (*tc*), separating the anterior vertical face from posterior horizontal part of tergite 1, occurs in *Symmorphus*, *Orancistrocerus*, *Pararrhynchium*, and *Ancistrocerus*, but is dorsally or in the middle interrupted or evanescent in *Orancistrocerus* and *Pararrhynchium*. A much reduced condition is observed in *Okinawepipona* in which the tergite bears a short carina on the lateral face (Giordani Soika, 1986; Nakamine, 1987; Yamane, 1987).

Longitudinal furrow on tergite 1 (Fig. 16). The furrow (*lf*) is rather wide and deep in *Symmorphus*. It is slitlike and situated only apically in *Pseumenes*. Many other genera have the horizontal part of the tergite 1 more or less depressed, but in *Rhynchium*, *Anterhynchium* and *Euodynerus* no trace of furrow or depression is found. There is a transverse depression anterior to the thickened apical margin in *Discoelius*.

Apical margin of tergite 1. Condition of this part is quite variable, but is divided into two principal types (Nakamine, 1987). Apical margin may be strongly thickened into a cordlike formation (*Discoelius*, *Eumenes*, *Oreumenes*)(tergite apically duplicate) or thickened but less cordlike (*Symmorphus*, "*Pachymenes*", *Allodynerus*), while in other genera (e.g., *Orancistrocerus*, *Pararrhynchium*, *Rhynchium*, *Anterhynchium*, *Euodynerus*) it is in the same plane as the disc of the tergite.

A narrow lamellate area occurs caudally on this tergite in some genera (*Discoelius*, *Eumenes*, *Symmorphus*, *Euodynerus*, *Stenodynerus*). In the last genus this area is apically dentate. A translucent area also occurs in *Rhynchium* and *Anterhynchium*.

Fore wing

Wing venation is rather stable among the Japanese Eumenidae. The condition in parastigma, 2nd recurrent vein and postnervulus may vary among genera.

Parastigma. Parastigma (*pst*) is usually half or less as long as stigma (=pterostigma: *st*). In *Oreumenes*, *Delta*, *Pseudozumia*, *Rhynchium* and *Anterhynchium* it is much longer, often as long as stigma. In *Pseumenes depressus* parastigma is somewhat long.

Color pattern

Color pattern is especially useful in separating subspecies (geographical races). In the Ryūkyū Islands some eumenids have several geographical races (color forms). Distinct regional convergence in color pattern is seen on the Yaeyama group and Okinawa group among species involving those of other families. Color pattern is also important at the specific level. For example, two very closely related species of *Allodynerus* are nearly constantly discriminated from each other solely by the color pattern.

In general the male wasps are more abundantly marked with light colors, and xanthic forms tend to occur more often in the southern part of a given distribution range. But exceptions to the latter rule are not rare, especially in insular regions. For example, a remarkably melanic form of *Anterhynchium flavomarginatum* inhabits Tsushima situated between Kyūshū and Korea. Forms occurring on Okinawa-jima are usually darker in maculation than those on Amami-ōshima situated northerly.

V. TAXONOMY OF THE JAPANESE EUMENIDAE

Key to the Japanese genera of Eumenidae (applicable to the Japanese forms only)

This key is chiefly based upon Yamane (1982a) and Giordani Soika (1978). Useful information can also be drawn from Kurzenko (1978), who studied the USSR genera of Eumenidae.

1. Mid tibia apically with two spurs. Mandibles short, medially not crossing each other. Gastral segment 1 slender, petiolate. Mesoscutum with developed notaulices. Tergite 1 with neither transverse carina nor longitudinal furrow. [Hokkaidō - Kyūshū, N. & C. Ryukyus] *Discoelius*
- Mid tibia with only one apical spur. 2
2. Tergite 1 with both a longitudinal furrow on the posterior horizontal part and a transverse carina between the anterior vertical face and horizontal part. Gastral segment 1 more or less narrowed, sometimes longer than wide. Notaulices on mesoscutum generally developed. Tergites 2-6(7) usually almost impunctate, shining. [Hokkaidō - Kyūshū] *Symmorphus*
- Tergite 1 without longitudinal furrow; at most the corresponding part slightly impressed. Gaster of variable shape. 3
3. Gastral segment 1 slender, distinctly petiolate. 4
- Gastral segment 1 stumpy, always wider than long, more than half as wide as segment 2. 9
4. Mesoscutum with distinct prescutal grooves. Mesepisternum with epicnemial carina. [S. Ryukyus] *Pseudozumia*
- Prescutal grooves and epicnemial carina absent. 5
5. Propodeum with several pairs of carinae obliquely running downward from the mid-line. Mesoscutum, scutellum, metanotum without conspicuous punctures. [S. Ryukyus] *Pseumenes*
- Propodeum without obliquely running carinae. Mesoscutum, scutellum, metanotum densely punctate. 6
6. Tergite 2 posteriorly with a well-defined lamellate area. Alitrunk subglobular. Tergite 1

- usually densely punctate, posteriorly more or less thickened. 7
- Tergite 2 without lamella. Tergite 1 without distinct punctuation, posteriorly not thickened. 8
7. Female clypeus apically truncate. Lateral part of propodeum rather clearly demarcated from posterior (dorsal) face. Terminal segment of male antenna very small, not recurved. [Hokkaidô - Kyûshû, N. and S. Ryukyus] *Oreumenes*
- Female clypeus apically more or less emarginate. Propodeum round on each side, without an edge between lateral and posterior face. Terminal segment of male antenna forming a recurved hook. [Hokkaidô - Kyûshû, N. Ryukyus] *Eumenes*
8. Tergite 1 longer, much longer than alitrunk. Male terminal sternite without longitudinal furrow. Metapleuron and lateral part of propodeum almost impunctate, shining. Body markings vivid yellow. [C. & S. Ryukyus] *Delta (Phi auct.)*
- Tergite 1 shorter, only slightly longer than alitrunk. Male terminal sternite with a longitudinal furrow. Propodeum laterally with punctures, not shining. Body with yellow and rufous markings. [C. & S. Ryukyus] *Delta*
9. Gastral segment 1 rather slender (but not distinctly petiolate), two-thirds as wide as segment 2. Tergite 2 with a pair of yellow spots. Mesopleuron with the epipleural suture quite evanescent. [C. & S. Ryukyus] "*Pachymenes*"
- Gastral segment 1 wider, usually more than four-fifths as wide as segment 2. Tergite 2 only rarely with a pair of yellow spots (*Stenodynerus kusigematii pachymenoides* often has such spots). 10
10. Tergite 1 with a transverse carina (sometimes medially obscure) between the anterior vertical face and posterior horizontal part. 11
- Tergite 1 without transverse carina (in *Okinawepipona* and some species of *Stenodynerus* the carina absent, but the anterior face rather sharply demarcated from the dorsal part). 13
11. Parastigma of fore wing more than half as long as stigma. Posterior half of mesoscutum and scutellum longitudinally and coarsely rugose rather than punctate. Propodeal crest not developed. Female clypeus wider than high, apically widely truncate. Thorax entirely black. The male is not found in the Japanese population. [Honshû - Kyûshû, N. Ryukyus] *Orancistrocerus*
- Parastigma half or less as long as stigma. Mesoscutum and scutellum punctate rather than rugose. Propodeal crest often developed. 12
12. Lateral face of propodeum strongly reticulate. Upper processes of propodeal crest pointed, close to each other. Female clypeus higher than wide, widely and shallowly emarginate at apex. Transverse carina on tergite 1 rather obscure in *P. ishigakiense*. [Honshû -Kyûshû, Ryukyus] *Pararrhynchium*
- Lateral face of propodeum striate, not distinctly punctate. Upper processes of crest, if any, blunt apically, widely separated from each other. Female clypeus wider than high, narrowly truncate or emarginate. [Hokkaidô - Kyûshû, N. Ryukyus]. *Ancistrocerus*
13. Parastigma of fore wing much more than half as long as stigma, sometimes even as long as stigma. Posterior end of tegula not reaching that of parategula. Tergite 1 without lamella posteriorly. 14
- Parastigma half or less as long as stigma. Posterior end of tegula reaching or extending beyond that of parategula. 15
14. Scutellum and posterior part of mesoscutum finely and sparsely punctate, slightly shining. Metanotum depressed medially (very weakly in the Japanese forms) and

- bluntly projecting laterally. [Honshû - Kyûshû; Ryukyus]*Rhynchium*
- Scutellum and posterior part of mesoscutum strongly and densely punctate, dull. Metanotum not projecting laterally. Propodeal crest well developed, with a pair of upper processes. Tergites 3-6 basally with many very large punctures (visible only when the segments are unusually extended). [Hokkaidô - Kyûshû, Ryukyus, Ogasawara]
.....*Anterhynchium*
 - 15. Pronotal carina often interrupted medially (dorsally). Pronotum with a pair of pits in the lower part of anterior vertical face, and sometimes with transverse striae above the pits. Tegula wide. Gastral segment 1 distinctly narrower than segment 2. Body relatively slender. [Hokkaidô - Kyûshû; Ryukyus; Ogasawara] *Stenodynerus*
 - Pronotal carina not interrupted medially. Pronotum without pits and striae on the vertical face. 16
 - 16. Tergites 1-5 each with a dark small spots in the brownish or yellowish apical band. Propodeum without crest. Male antennal hook very small. Basal part of sternite 2 with 14-18 strong, longitudinal carinae. [C. Ryukyus] *Okinawepipona*
 - Tergites 1-5 without such dark spots. 17
 - 17. Tergite 1 with a posterior lamellate area. Pronotum with punctures on the lateral parts of anterior vertical face. Clypeus (♀ ♂) higher than wide, only rarely as high as wide or slightly wider than high. Posterior end of tegula reaching or extending beyond that of parategula. Propodeum often with a pair of upper processes. [Hokkaidô - Kyûshû; Ryukyus; Ogasawara] *Euodynerus*
 - Tergite 1 without posterior lamellate area. Pronotum without punctures on anterior vertical face. Clypeus (♀ ♂) much wider than high; male clypeus deeply incised apically. Posterior end of tegula produced beyond that of parategula. Propodeum without upper processes. [Hokkaidô, Honshû] *Allodynerus*

Genus *Discoelius* Latreille

Discoelius Latreille, 1809, Gen. Crust. Ins. 4: 140 (subgenus of *Eumenes* Latreille)(type species: *Vespa zonalis* Panzer, 1801, monotypic).

Tritodiscoelius Dalla Torre, 1904, Gen. Ins. 19: 18 (division of *Discoelius*)(type species: *Vespa zonalis* Panzer, 1801, designated by Bequaert and Ruiz, 1942).

Japanese name: Futasuji-suzubachi Zoku.

Latreille's genus *Discoelius* was characterized by Saussure (1852) as follows. "Labium moderately long, large; labial palp 4-segmented; segment 1 slightly widened apically. Maxillary palp 6-segmented; segments 1-3 long (3>2>1), and the rest shorter; galea rather short. Mandible obliquely truncate apically, wider at apex than at base. Antenna long, club-shaped, inserted at the middle of the head. Head slightly concave posteriorly; the sides of head not entirely occupied by the eyes; ocular sinus deep. Thorax long. Propodeal groove well defined. Gaster with petiole (1st segment) which is strongly widened in the middle then becomes oval; segment 2 bell-shaped, longer than wide. Fore leg with very long, curved femur and much shorter tibia".

Saussure recognized three species groups (divisions I-III) in the genus, and Dalla Torre (1904) named them *Protodiscoelius* (New World), *Deuterodiscoelius* (Tasmania), and *Tritodiscoelius* (Palearctic). The last division, to which the Asian forms belong, was

characterized by Saussure as follows: "Galea short; maxillary palp shorter than the basal part of maxilla, rather thick. Petiole short, campanulate in the midst, strongly swollen dorsally and rimmed posteriorly. Cubital cell 2 with distinct border to radial sector (*offrant un bord radial sensible*)".

Later, Bequaert and Ruiz (1942) (after Carpenter, 1986) raised Dalla Torre's divisions to genera, and *Tritodiscoelius* was synonymized with *Discoelius*. Only one species (*D. japonicus*) is known to occur in Japan in spite of the fact that three other species have been recorded from the Far East (Yasumatsu, 1934; Vecht and Fischer, 1972), *D. manchurianus* Yasumatsu from South Manchuria, *D. zonalis* (Panzer) from Ussuri and Sakhalin, and *D. esakii* Yasumatsu from Taiwan.

Discoelius japonicus Pérez

(Figs. 20-26)

Discoelius japonicus Pérez, 1905, Bull. Mus. Hist. Nat. Paris 1905(2): 85 (♀)(type loc.: Japon central); Yasumatsu, 1930, Mushi, 3(1): 35; Yano, 1932, Icon. Ins. Jpn. p. 312; Ishikawa, 1965, Icon. Ins. Jpn. Col. Nat. Ed. 3: 292, pl. 146, fig. 15.

Japanese name: Futasuji-suzubachi.

Diagnosis. Good descriptions were given for both the sexes by Yasumatsu (1930, 1934). Body length (h+th+t1+2): 12.0-15.0 mm in ♀, 7.5-12.0 mm in ♂. Fore wing length: 9.5-14.0 mm in ♀, 7.5-9.5 mm in ♂. In the female, the lamella of gastral tergite 2 is usually developed and slightly reflex, but in the specimens from Hokkaidō and Fukushima-ken (Honshū) it is often very narrow and not reflex at all. Yellow and orange body markings are relatively stable throughout the distribution range. In the specimens from Hokkaidō, however, these markings are generally reduced; sometimes clypeus is almost wholly black and a spot just above the antennal socket is often lost.

The male is readily distinguished from the female by the following points as well as by usual sexual characters: posterior face of propodeum more strongly rugoso-reticulate and rather shining; punctuation on the sides of tergite 1 stronger; tergite 3 as well as 2 with a developed lamella posteriorly that is distinctly reflex; yellow markings on mandible and clypeus much larger, while antennal scape entirely blackish, and supra-antennal spot always lost.

Material examined. Hokkaidō: 1♀, Izumi, Niikappu, 3 viii 1974 (T. Sunose), 1♀, Hakken-zan, Sapporo, 13 vii 1975 (H. Taoka), 1♀, Shintoku, 16 vii 1977 (M. Kiuchi), 1♀, Toyotaki, Sapporo, 28 viii 1977 (SKY), 1♀, Muine-yama, Sapporo, 9 viii 1978 (K. Kawamura), 1♀, Nukabira, 19 vii 1979 (SKY), 1♀, Kamui, Asahigawa, 19 vii 1979 (T. Inaoka), 1♀, Heiwa-no-taki, Sapporo, 3 viii 1979 (K. Kawamura).

Honshū: *Yamagata-ken* - 1♀, Nan'yō-shi, 11 vii 1976 (HI), 1♀, Oguni, 1 viii 1976 (HI), 2♂♂, Nan'yō-shi, 13 vii 1978 (HI), 2♀♀, 11-26 vii 1981 (HI), 1♂, Tamagawa, Oguni, 24 vi 1981 (KB); *Fukushima-ken* - 1♀, Yunohana, Aizu, 21 vi 1977 (HI), 1♀, same loc., 9 vi 1978 (HI), 1♀, same loc., 23 vii 1978 (HI), 1♀, Mishima, 24 vi 1980 (HI), 2♀♀, Tadami, 25 vi 1980 (HI), 2♀♀, Yunohana, Aizu, 27 vii 1980 (HI); *Miyagi-ken* - 1♀, Rifu, 8 vi 1980 (K. Goukon); *Niigata-ken* - 1♀, Asahi-mura, 21 ix 1965 (KB), 9♀♀, Maki, 30 v - 3 vi 1973 (reared by YM), 1♀, Shidai-hama, 10 vii 1974 (HI), 1♀, Murakami, 21 vi 1976 (T. Sunose), 1♀, Nagaoka, 10 vii 1976 (SKY), 1♀, Kakuda-san, 8 vii 1976 (SKY), 1♀, Senami, 29 ix 1979 (KB), 1♂, same loc., 5 ix 1981 (KB), 3♀♀, Sato, Suibara, 12-13 x 1981 (A. Seino); *Tochigi-ken* - 1♀, Utsunomiya, 22 viii 1970 (T. Hasegawa); *Gumma-ken* - 2♂♂, Hotaka-san, 8 viii 1976 (HI); *Shizuoka-ken* - 1♀, Hirano, Shizuoka, 18 ix 1977 (T. Hattori); *Nagano-ken* - 1♀, Ōmachi, 5 vi 1982 (W. Miyata).

Kyūshū: *Kagoshima-ken* - 1♀, Kagoshima-shi, 8 vi 1984 (S. Higashi).

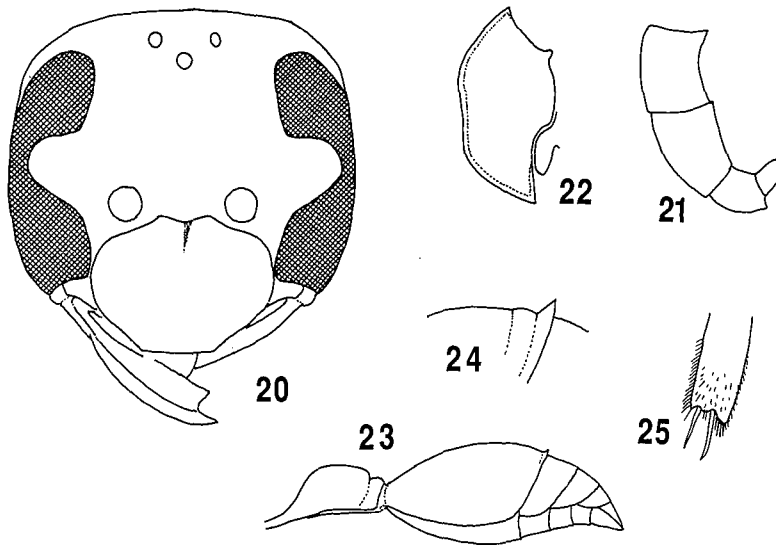

Figs. 20-25. *Discoelius japonicus*. 20, head in front (♀); 21, terminal segments of male antenna; 22, tegula and parategula; 23, gaster in profile (♀); 24, apical margin of gastral tergite 2 in profile (♂); 25, apex of mid tibia (♀).

Distribution. Hokkaidô; Honshû; Shikoku; Kyûshû; Ôsumi Is. (Tane-ga-shima; Yakushima); Amami Is. (Amami-ôshima). Korea (Kim, 1970); China (Lee, 1985).

Taxonomic notes. This species is easily distinguished from all other Japanese eumenids by having two apical spurs on the mid tibia. It disagrees with the diagnosis given by Saussure (1852) for Div. III of *Discoelius* in that maxillary palp is longer than the basal part of maxilla and rather slender.

Biology. Masuda (1937) and Tsuneki (1970) gave detailed accounts of nesting biology of *D. japonicus* in Japan. This species is unique among the Japanese Eumenidae in utilizing plant leaf pieces as walls partitioning the nest into cells. According to Masuda, nests are made in bamboo and reed tubes set up as trap nests, or, under natural conditions, in tunnels in dead tree twigs bored by coleopterous larvae and in broken stems of herbs. The female wasp first applies pellets of mesophyll mixed with her saliva as an adhesive to a suitable part in the tube, then collects and carries a leaf piece into it and attaches it to the applied adhesive. Subsequent leaf pieces are used one by one to complete a wall. In total an average of 4.1 leaf pieces (range: 1-12) are needed for each wall. Wasps collect material from broad-leaved trees such as *Rosa* spp. and *Prunus avium*. A nest consists of 4-11 cells, of which 30-83 % are "empty" cells in which 2-9 leaf pieces are usually carried. These cells seem to prevent brood cells from parasitism. An egg is hung in a cell from the ceiling by a thread of approximately 1 mm long, then 2-10 (mean: 5.4) caterpillars of the moth families Pyralidae and Tortricidae are carried in. The full-grown larva of wasp measures on average 12.3 mm in the male and 14.5 mm in the female. The cocoon is pale brown in color and cylindrical in shape. Although Yasumatsu (1930) mentions that male wasp must be quite rare (his material contained no male), Masuda's (1937) data shows an approximately 1:1 sex ratio in at least collected nests that produced adult wasps. This species is considered to be trivoltine in Yamanashi-ken, Honshû (Masuda, 1937).

Parasitoids: *Chrysis* (*Hexachrysis*) *zetterstedii*, *C. daphne*, *C. ignita* (Hymenoptera, Chrysididae)(Baba, 1937; Tsuneki, 1973), *Melittobia acasta* (Hymenoptera, Eulophidae) (Maeta & Yamane, 1974, referred to as *M. japonica*; Maeta, 1985), a bee fly (Diptera, Bombyliidae)(Masuda, 1937), *Amobia signata* (Diptera, Sarcophagidae) and *Macrosiagon* sp. (Coleoptera, Rhipiphoridae)(Yamane & Maeta, unpubl.).

Genus *Stenodynerus* Saussure

Stenodynerus Saussure, 1863, Mém. Soc. Phys. Hist. Nat. Genev. 17: 228 (as division of subgenus *Odynerus* of genus *Odynerus* Latreille)(type species: *Odynerus chinensis* Saussure, 1863, designated by Bohart, 1939); Vecht, 1966, Entomol. Berichten, 26: 163 (as genus); Carpenter, 1986, Psyche, 93: 85 (as genus).

Nannodynerus Blüthgen, 1938, Konowia, 16: 281 (as subgenus of "*Euodynerus* Blüthgen")(type species: *Lionotus teutonicus* Blüthgen, 1937, original designation).

Japanese name: Chibi-dorobachi Zoku.

The wasps of this genus have a small and rather slender body, not exceeding 10 mm

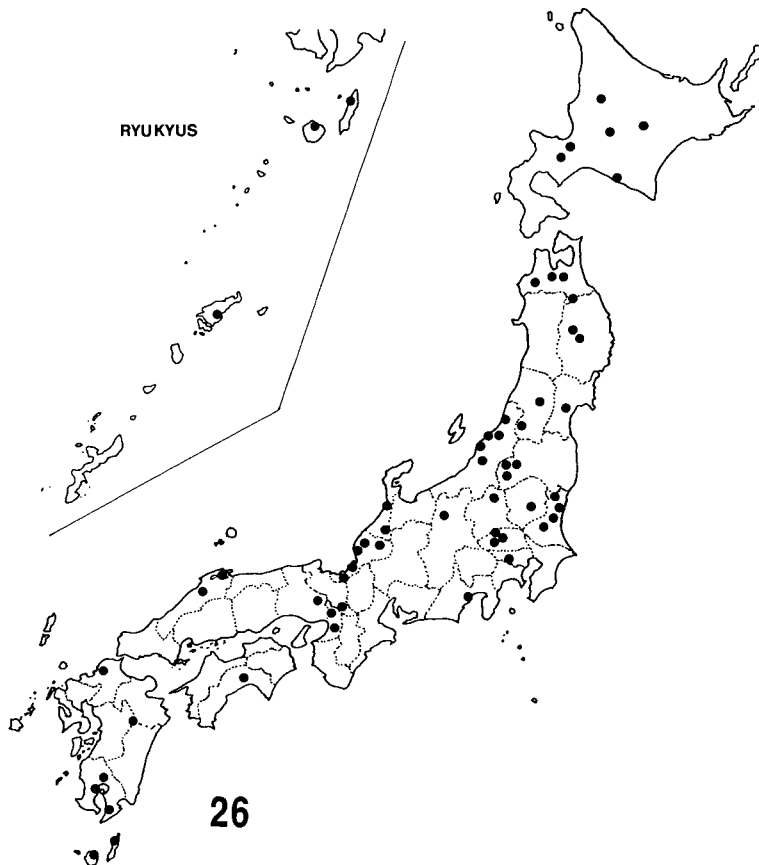

Fig. 26. Distribution of *Discoelius japonicus*.

in total length in at least Japanese species. Gastral tergite 1 is distinctly narrower than tergite 2, but not petiolate. Anterior vertical face of pronotum with a pair of pits in its lower portion, and sometimes with transverse striae above the pits (Fig. 13). Cephalic foveae are usually very small and inconspicuous, located just in front of a slightly curved carina (Figs. 29-31). In *frauenfeldi*, *rufomaculatus*, *chinensis* and *clypeopictus* the foveae are very close to each other and sometimes connected (Figs. 29, 30). In *ogasawaraensis* they are quite inconspicuous, usually not distinguished from nearby punctures. In *tokyanus* and *kusigematii* (Fig. 31) they are apart from each other as usual with many eumenids. Maculation of tegula and parategula is often useful to distinguish between the species (Figs. 48-57).

The genus is mainly Holarctic in distribution, with fewer species in Neotropical and Oriental regions. Australia lacks this genus (Taylor et al., 1985). The Palearctic species were revised by Gusenleitner (1981), and 34 species were enumerated in five tentative species groups. In Japan eight species occur and are tentatively divided into four species groups (Yamane & Tano, 1987). Structural characteristics for the Japanese species are given in Gusenleitner (1981) and Yamane and Gusenleitner (1982), and are accordingly not repeated here.

Key to the Japanese species of *Stenodynerus*

1. Lateral sides of propodeum only finely punctate, not reticulate. Clypeus not distinctly emarginate apically (♀). Gastral tergites 1 and 2 rufous, with yellow apical bands.
..... *S. ogasawaraensis* Yam. et Gusnl.
- Lateral sides of propodeum coarsely punctate or reticulate at least partly. Clypeus more or less emarginate apically (♀). Tergite 2 always black, with a yellow or rufous apical band. 2
2. Propodeum without horizontal space (propodeal shelf) behind metanotum. Anterior vertical face of tergite 1 clearly demarcated from the posterior horizontal part, almost impunctate, and shining (in the male this demarcation is less distinct, and the vertical face often punctate). Anterior vertical face of pronotum without transverse striae. 3
- Propodeum with a narrow but distinct shelf. Tergite 1 with round border between anterior vertical face and posterior horizontal part; the former strongly punctate in its upper portion. Anterior vertical face of pronotum with transverse striae in its upper part. 4
3. Clypeus distinctly wider than high (♀). Anterior vertical face of pronotum coarsely punctate. Posterior horizontal part of pronotum and mesoscutum with large punctures that are larger than interspaces. *S. tokyanus* (Kost.)
- Clypeus as wide as long, or at most only slightly wider than long (♀). Anterior vertical face of pronotum with much finer and sparser punctation. Posterior horizontal part of pronotum and mesoscutum with smaller punctures that are often as large as or smaller than interspaces. *S. kusigematii* Yam. et Gusnl.
4. Occipital carina bent at the level of clypeal base, forming a distinct angle there. Pronotal carina distinct dorsally, forming a narrow transparent lamella, interrupted only in the middle. 5
- Occipital carina more smoothly curved, without distinct angle. Pronotal carina less

- developed, dorsally not forming a lamella. 6
5. Gastral tergite 1 largely rufous or orange. Propodeum without upper teeth behind metanotum. Tergite 2 superficially punctate. *S. rufomaculatus* Yam. et Gusnl.
- Tergite 1 black, with a yellow apical band. Propodeum often with distinct teeth behind metanotum. Tergite 2 coarsely punctate; punctures only slightly smaller than those on tergite 1. *S. frauenfeldi* (Sauss.)
6. Tibiae of all legs yellow (♀). Clypeus with fine, sparse, superficial punctation (♀). Terminal segment of male antenna large, seen from below, wide and parallel-sided; its apical half yellow; segment 11 ventrally slightly concave to receive the terminal segment. Innerorbit with a yellow stripe in its lower part (♂). Tegula marked with yellow on anterior and posterior parts. *S. clypeopictus* (Kost.)
- Mid and hind tibiae brown or black (♀). Clypeus with deep and dense punctures (♀). Terminal segment of male antenna much more slender, narrowed toward apex, wholly blackish; ventral face of segment 11 not concave. Innerorbit without yellow stripe (♂). Tegula usually blackish brown, only rarely with a small spot on its anterior part. *S. chinensis* (Sauss.)

Frauenfeldi group

Stenodynerus frauenfeldi (Saussure)

(Figs. 27, 29, 32, 39, 43, 46-48)

Odynerus (Lionotus) frauenfeldi Saussure, 1867, *Reise der Novara*, Zool. 2(1) Hym. p. 15 (♀) (type loc.: Shanghai, China); Yasumatsu, 1935, *Kontyû*, 9: 225-227 (part).

Odynerus (Hoplomerus) nigriclypeatus Sonan, 1930, *Trans. Nat. Hist. Soc. Formosa*, 20: 356 (♀) (type loc.: Kagoshima, Kyûshû).

Odynerus apiciornatus: Yano, 1932, *Icon. Ins. Jpn.* 1st ed. p. 309, fig. 600 (misidentification).

Stenodynerus frauenfeldi: Ishikawa, 1965, *Icon. Ins. Jpn. Col. Nat. Ed.* 3: 297, pl. 149, fig. 7; Gusenleitner, 1981, *Polsk. Pismo Entomol.* 51: 287-289; Yamane and Gusenleitner, 1982, *Rep. Fac. Sci. Kagoshima Univ.* 15: 113 (in key), 116-118.

Japanese names: Kiobi-chibi-dorobachi (Chibi-dorobachi; Hime-futaobi-dorobachi).

Diagnosis. Body length (h+th+t1+2): 7.0-8.5 mm in ♀, 5.5-6.5 mm in ♂. Fore wing length: 6.5-7.0 mm in ♀, 5.0-6.0 mm in ♂.

Female. Black, with the following parts yellow: a basal markings on clypeus (clypeus usually wholly black), a round frontal spot, a basal marking on mandible (sometimes lost), a minute spot on temple, a pair of markings on pronotum anteriorly, tegula extensively, parategula, a spot on dorsal mesepisternum, metanotum largely, a pair of spots on propodeum dorsolaterally, regular apical bands on gastral tergites 1 and 2, posterolateral corners of sternite 2 (the sternite sometimes with a complete apical band), anterior face of fore tibia.

Male. More extensively marked with yellow as follows: clypeus wholly, mandible largely, frontal spot, antennal scape below, small spot on temple, an anterior band on pronotum (laterally narrower than in ♀), anterior faces of all tibiae, those of mid and hind coxae (often reduced). Other markings on alitrunk and gaster as in ♀ (sternite 2 almost always with an apical band).

Material examined. Hokkaidô: 1♂2♀♀, Sapporo, 5 vii 1954 (K. Kamijo), 1♀, Esashi, 9 ix 1958 (T.

Kumata, 2 ♂♂, Toyotaki, Sapporo, 29 viii 1979 (SKY), 1 ♀, Misumai, Sapporo, 6 viii 1980 (S. Makino).

Honshū: *Iwate-ken* - 1 ♀, Kuriyagawa, Morioka, 23 vi 1964 (YM), 2 ♀♀, Jōhōji, 21 viii 1982 (HI), 3 ♂♂ 2 ♀♀, Kanegasaki, 2 viii 1987 (SKY); *Fukushima-ken* - 1 ♂, Yunohana, 21 vi 1977 (HI); *Niigata-ken* - 2 ♀♀, Muroya, Mikawa, 1 ix 1977 (HI), 6 ♂♂ 1 ♀, Sato, Suibara, 15 vii 1979 (A. Seino), 1 ♀, Senami, 2 vii 1983 (KB), 1 ♂, Shibata, 3 ix 1979 (HI), 1 ♂, Ishizumi, Asahi, 27 ix 1984 (KB); *Ibaraki-ken* - 2 ♂♂, Tsuchiura, 29 viii 1976 (SKY); *Nagano-ken* - 1 ♂ 1 ♀, Minamiminowa, Ina, 6-8 vi 1962 (YM), 7 ♂♂ 3 ♀♀, Habiro, Ina, 31 vii 1962 (YM), 2 ♀♀, Saku, 27-28 vii 1973 (YM), 1 ♀, Todo, Otari, 26 viii 1982 (KB); *Yamanashi-ken* - 1 ♂ 1 ♀, Wada-tōge, Kōfu, 24 vii 1965 (K. Iwata); *Ishikawa-ken* - 1 ♀, Kaga, Haku-san, 17 vii 1953 (K. Nohara); *Fukui-ken* - 1 ♀, Ōno, 10 vii 1971 (YH), 1 ♂, same loc., 15 ix 1971 (YH); *Gifu-ken* - 1 ♀, Horado, 7 viii 1982 (Y. Takai); *Aichi-ken* - 1 ♂, Irako, Atsumi Pen. 6 viii 1977 (Y. Takai); *Wakayama-ken* - 1 ♀, Kiitanabe, 4 viii 1965 (K. Iwata); *Hyōgo-ken* - 1 ♂, Sasayama, Tamba, 24 vi 1950 (K. Iwata); *Shimane-ken* - 1 ♀, Oba, Matsue, 10 vii 1986 (N. Sugiura).

Nanatsu-jima Is. (Ishikawa-ken): *Hegura-jima* - 2 ♂♂, 26 v 1983 (R. Ohgushi); *Ōshima* - 4 ♂♂ 1 ♀, 11 vi 1983 (R. Ohgushi).

Izu Is. (Tōkyō-to): *Hachijō-jima* - 2 ♂♂, Okagou - Fuji, 26 v 1964 (Y. Hirashima & M. Shiga), 1 ♂, Kamogawa, Mitsune, 12 vii 1987 (H. Takahashi), 1 ♀, Okagou - Eigou, 16 viii 1987 (H. Takahashi); *Ao-ga-shima* - 1 ♀, Yasundogou, 8 vii 1987 (H. Takahashi).

Shikoku: *Kōchi-ken* - 1 ♀, Monobe, Nankoku, 2 v 1974 (SI), 1 ♀, Okoyama, Nankoku, 2 vii 1975 (SI); *Kagawa-ken* - 4 ♂♂, Miki, 23 vii 1963 (K. Iwata); *Ehime-ken* - 1 ♂, Matsuyama, 10 viii 1969 (HI); *Tokushima-ken* - 1 ♀, Tsudayama, 22 viii 1964 (H. Iwasaki).

Kyūshū: *Fukuoka-ken* - 1 ♀, Shingū, Fukuoka-shi, 9 x 1983 (AN), 1 ♀, Ushirogōchi, Kurogi, 27 vii 1983 (Y. Takai); *Nagasaki-ken* - 1 ♂, Haraguchi, Ōmura, 18 vi 1966 (R. Ohgushi), 1 ♀, same loc., 24 viii 1966 (R. Ohgushi); *Kumamoto-ken* - 2 ♂♂, Kagami, 5 v 1982 (M. Maeda), 5 ♂♂ 2 ♀♀, same loc., 31 v 1982 (M. Maeda); *Kagoshima-ken* - 4 ♂♂ 1 ♀, Ichiki, 11 vi 1984 (AN), 5 ♂♂ 3 ♀♀, Jingū, Kirishima, 3 vii 1981 (SKY), 1 ♀, Shiroyama, Kagoshima-shi, 16 x 1980 (SI), 2 ♀♀, same loc., 30 vii 1981 (SKY), 5 ♂♂ 2 ♀♀, Kōrimoto, Kagoshima-shi, 6-7 viii 1981 (SKY), 2 ♂♂, Ibusuki - Kiire, 13 x 1963 (H. Tanaka), 1 ♂, Izashiki, Sata, 3 viii 1963 (A. Tanaka).

Tsushima Is. (Nagasaki-ken): *Kami-agata* - 1 ♂, Nii, Toyotama-son, 20 viii 1968 (I. Hiura); *Shimo-agata* - 1 ♂, Izuhara, 27 vii 1986 (K. Nakamine).

Gotō Is. (Nagasaki-ken): *Aka-shima* - 1 ♂ 1 ♀, 17 viii 1976 (J. Nakayama).

N. Ryukyus: *Ie-jima* (Uji Is.) - 1 ♂, 11 v 1985 (H. Fukuda); *Tane-ga-shima* - 2 ♂♂ 1 ♀, Kaminaka, 11-12 vii 1983 (SKY), 2 ♂♂ 2 ♀♀, Hamada, 11 vii 1983 (SKY), 3 ♂♂ 1 ♀, same loc., 1-2 viii 1984 (SKY); *Mage-shima* - 3 ♂♂, 22 vii 1984 (S. Watahiki); *Yaku-shima* - 3 ♂♂ 1 ♀, Miyanoura, 8-11 viii 1981 (SKY), 5 ♂♂, Shitogo, 10 viii 1981 (SKY), 1 ♂, Ambō, 11 v 1981 (SKY), 1 ♀, Kurio, 4 x 1981 (Y. Takai); *Kuchinoerabu-jima* - 1 ♀, Hommura, 15 vi 1989 (H. Watanabe).

C. Ryukyus: *Amami-ōshima* - 1 ♂, Naze, 20 vi 1987 (SKY), 6 ♂♂ 1 ♀, Setouchi, 22 vi 1987 (SKY), 2 ♂♂ 1 ♀, Shinokawa, 23 vi 1987 (SKY).

Distribution. Hokkaidō; Honshū; Nanatsu-jima Is. (Ōshima; Hegura-jima); Izu Is. (Hachijō-jima; Hachijō-kojima; Ao-ga-shima); Shikoku; Kyūshū; Tsushima Is. (Kami-agata; Shimo-agata); Gotō Is. (Aka-shima); Ōsumi Is. (Ie-jima; Tane-ga-shima; Mage-shima; Yaku-shima; Kuchinoerabu-jima); Amami Is. (Amami-ōshima); Ogasawara Is. (introduced?). China. Yasumatsu (1935d) recorded "*Odynerus frauenfeldi*" from Sado-ga-shima.

Taxonomic notes. Three species (*frauenfeldi*, *chinensis* and *tokyanus*) might have been confused in Japan under the name *Odynerus frauenfeldi* or *Stenodynerus frauenfeldi* (e.g., Yasumatsu, 1935b). Further, the description of the female of *Odynerus apiciornatus* by Yano (1932) well agrees with *Stenodynerus frauenfeldi*.

In a few female specimens from Kyūshū and the N. and C. Ryukyus, the scutellum and mid tibia are marked with yellow. But the color pattern is rather stable throughout the distribution range in Japan.

Yamane and Gusenleitner (1982) pointed out that abscissa 4 of radius is as long as or slightly longer than abscissa 3 in *S. frauenfeldi*, but distinctly longer than the latter in *S. rufomaculatus*. But, in some specimens (especially males) of *frauenfeldi*, abscissa 4 is much

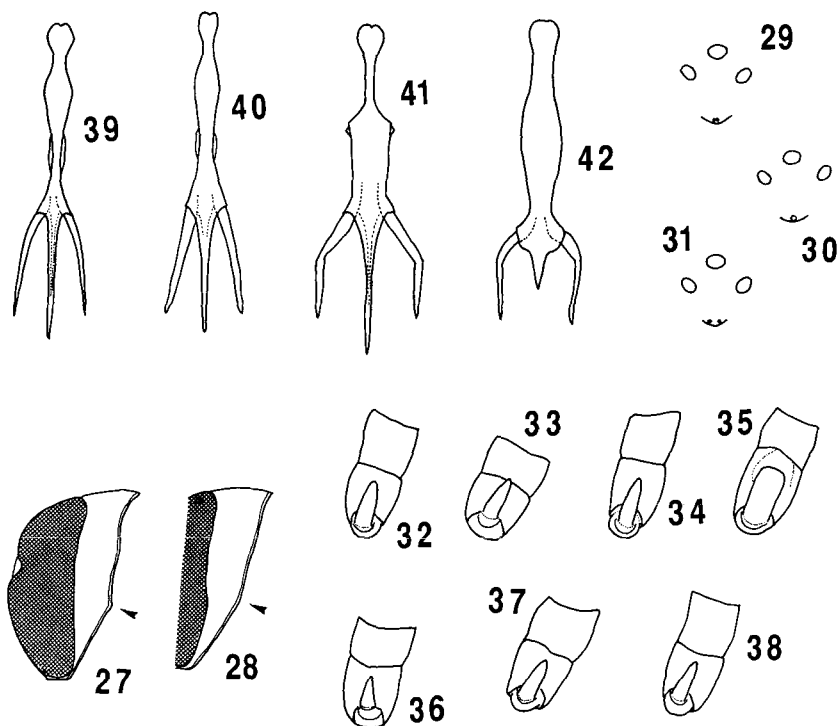

Figs. 27-42. Various characters in the Japanese *Stenodynerus*. 27, 28, head in profile of *frauenfeldi* (27) and *chinensis* (28), showing the condition of occipital carina; 29-31, ocellar region (♀) of *frauenfeldi* (29), *rufomaculatus* (30), *kusigematii* (31); 32-38, terminal segments of male antenna (from below) in *frauenfeldi* (32), *rufomaculatus* (33), *chinensis* (34), *clypeopictus* (35), *tokyanus* (36), *kusigematii* (37), *ogasawaraensis* (38); 39-42, penis of male genitalia in *frauenfeldi* (39), *rufomaculatus* (40), *chinensis* (41), *clypeopictus* (42).

longer than 3, and in the female specimens of *rufomaculatus* from Yoron-tô abscissa 4 is often as long as 3. In some males of *frauenfeldi* abscissa 2 is almost lacking.

Biology. As mentioned above, in Japan two or three species have been confused under the name *frauenfeldi* even by taxonomists. The biology of Japanese *Stenodynerus* has been studied mainly by Iwata (1938b, 1980a) and Tsuneki (1961, 1969). The material used by Iwata (1938b) was identified by Yasumatsu, who erroneously believed that only one species of this genus occurred in Japan. When I examined Iwata's collection at Kobe University, I found that specimens of three *Stenodynerus* species (*frauenfeldi*, *chinensis* and *tokyanus*) and *Allodynerus mandschuricus* were placed together under the head identification label "*Stenodynerus frauenfeldi*". Although the photo of a nesting female in Iwata (1982) is never of *S. frauenfeldi* (it is probably of *S. tokyanus* or even of *A. mandschuricus*), the figure drawn by him (Iwata, 1980a, p. 39) is correctly a female of *S. frauenfeldi*. The female illustrated by Tsuneki (1961) is also no doubt *S. frauenfeldi*. The following description may include information about the biology of two or three species.

Nests are constructed in pre-existing hollow tubes (3-4 mm in diam.), such as the pith hollow of reed cane and the stems of bamboo-grass and flax. As these plants were formerly utilized as blinds, fences and roofs, *Stenodynerus* females were abundant around

houses in rural regions. The nest consists of two or three brood cells (maximum: 6), and usually two long empty cells, one in the back and the other in front. Cells are partitioned with mud. Thirteen to 76 leaf-mining microlepidopterous larvae of the families Lyonetiidae, Gracillariidae and Gelechiidae (4-5 mm long) are stored in each brood cell. Hunting habits and prey species are given in Iwata (1963, 1980a). The egg is laid before hunting, but Tsuneki (1969) suspected that the female wasp carried one or two prey caterpillars into a cell prior to oviposition (behavior of the female within nest was not observed). The color vision and figure discriminating capacity was intensively studied by Tsuneki (1961).

Parasite: *Pseudoxenos minor* (Strepsiptera, Stylopidae) (Kifune & Maeta, 1987). Parasitoids: a phorid fly (Diptera) mainly attacking prey ?, and *Chrysis viridula* (Hymenoptera, Chrysididae).

Stenodynerus rufomaculatus Sk. Yamane et Gusenleitner
(Figs. 30, 33, 40, 47, 49)

Stenodynerus rufomaculatus Yamane and Gusenleitner, 1982, Rep. Fac. Sci. Kagoshima Univ. 15: 118-119, figs. 4, 8 (♀ ♂) (type loc.: Okinawa-jima).

Stenodynerus rufomaculatus kikaiensis: Yamane and Tano, 1987. Trans. Shikoku Entomol. Soc. 18: 328 (♀ ♂) (type loc.: Kikai-jima, Amami Is). **Syn. nov.**

Japanese name: Akaobi-chibi-dorobachi.

Diagnosis. Body length (h+th+t1+2): 6.5-7.0 mm in ♀, 5.5-7.0 mm in ♂. Fore wing length: 6.0-6.5 mm in ♀, 4.5-6.0 mm in ♂. Structurally similar to the preceding species, but differs from the latter in the following points: abscissa 4 of radial vein of fore wing usually distinctly longer than abscissa 3 (♀ ♂), propodeum without distinct processes behind metanotum (♀ ♂), clypeus as wide as high (♂).

In coloration, this species is easily distinguished by orange gastral markings. Orange are: a large markings on propodeum (in ♂ often reduced or lost), posterior horizontal part of gastral tergite 1 extensively, sternite 1, a wide apical band on tergite 2, a narrower band on sternite 2. Pair of large markings on pronotum yellow, often tinged with orange. The following parts are yellow: clypeus largely (in ♀ often black in peripheral and lower parts; in ♂ wholly yellow), frontal spot, mandible largely (♂; in ♀ black with apical half ferruginous), antennal scape below (♂), small spot on temple, tegula except for central part and margins, parategula, a spot on dorsal mesepisternum (often lost in ♂), metanotum, anterior face of fore tibia (♀), anterior face of mid coxa (♂), apical part of fore and mid femora (♂), tibiae of all legs extensively (♂).

Material examined. C. Ryukyus: *Kikai-jima* - 5 ♂ ♂ 1 ♀, Nakazato, 26-27 viii 1984 (S. Watahiki), 6 ♂ ♂, same loc., 18 x 1987 (SI); *Kakeroma-jima* - 1 ♀, Nishiamuro, 28 ix 1987 (SKY); *Okinoerabu-jima* - 1 ♂, Kimidome, 9 viii 1967 (T. Murota), 1 ♂, Shinjō - Tamina, 14 vii 1984 (Y. Takai); *Yoron-tō* - 3 ♂ ♂ 3 ♀ ♀, Maenohama, 4 vi 1989 (SKY); *Okinawa-jima* - 1 ♂, Oku, Kunigami, 4 viii 1982 (YH).

Distribution. Amami Is. (Kikai-jima; Kakeroma-jima; Okinoerabu-jima; Yoron-tō); Okinawa Is. (Okinawa-jima; Kume-jima).

Taxonomic notes. Yamane and Tano (1987) regarded the population of Kikai-jima as a subspecies (*kikaiensis*), but the present material shows that the supposed difference is not constant. Up to the present this species has not been collected on Amami-ōshima, where the closely related *S. frauenfeldi* is relatively common.

Biology. On Yoron-tô many female wasps were seen flying around limestones along the coast, but nesting biology is not yet known.

Parasite: *Pseudoxenos* sp. (new record).

Stenodynerus chinensis simillimus Sk. Yamane et Gusenleitner

(Figs. 28, 34, 41, 44, 47, 50-52)

Odynerus (Lionotus) chinensis Saussure: Schulthess, 1934, Arb. Morph. Taxon. Entomol. 1: 91.

Odynerus (Lionotus) frauenfeldi: Yasumatsu, 1935, Kontyû, 9: 225-227 (part).

Stenodynerus chinensis simillimus Yamane and Gusenleitner, 1982, Rep. Fac. Sci. Kagoshima Univ. 15: 119-121, fig. 14 (♀ ♂) (type loc.: Morioka, Honshû).

Japanese name: Kataguro-chibi-dorobachi.

Diagnosis. Body length (h+th+t1+2): 7.0-8.5 mm in ♀, 5.5-6.5 mm in ♂. Fore wing length: 6.5-7.0 mm in ♀, 5.0-6.0 mm in ♂.

Female. Black, with the following parts yellow: round frontal spot, a stripe on mandibular base, minute spot on temple, a stripe on antennal scape below, a pair of markings on pronotum anteriorly (often reduced or lost), parategula, metanotum anteriorly, apical bands on gastral tergites 1 and 2 and sternite 2, anterior face of fore tibia. Clypeus usually wholly black, but rarely with yellow spots in upper portion. Tegula wholly blackish brown, only rarely with a yellow marking anteriorly.

Male. Similar to the female, but differs as follows: clypeus and mandible almost wholly yellow, pronotal and metanotal markings much more reduced, anterior face of mid coxa, tibiae of all legs extensively yellow, tarsi also marked with yellow.

Material examined. Hokkaidô: 1 ♀, Jôzankei, 24 vi 1951 (K. Kamijo), 1 ♀, Bibai, 15 viii 1976 (A. Seino), 1 ♀, same loc., 3 x 1976 (K. Kamijo), 1 ♀, Toyotaki, Sapporo, 26 viii 1979 (SKY).

Honshû: *Aomori-ken* - 2 ♀ ♀, Yunokawa, Shimokita, 23 vii 1965 (T. Naito); *Iwate-ken* - 1 ♀, Kuriyagawa, Morioka, 5 ix 1968 (YM), 1 ♂ 1 ♀, Jôhôji, 21 viii 1982 (HI), 2 ♂ ♂ 1 ♀, Kanegasaki, 2-3 viii 1987 (SKY), 1 ♀, Ôshuku, Shizukuishi, 7 viii 1987 (SKY); *Yamagata-ken* - 1 ♂, Chôjuga-hara, Oguni, 22 vi 1979 (HI); *Miyagi-ken* - 1 ♀, Rifu, 14 ix 1980 (K. Goukon); *Niigata-ken* - 1 ♀, Nagaoka, 11 vii 1976 (S. Higuma), 1 ♀, Shibata, 28 viii 1976 (HI), 1 ♀, Muroya, Mikawa, 21 viii 1977 (HI), 1 ♀, Shidai-hama, 23 ix 1980 (HI), 2 ♂ ♂ 3 ♀ ♀, Senami, 5-18 vi 1983 (KB), 1 ♂, Kurokawa, 7 ix 1984 (KB), 1 ♀, Sarusawa, Asahi, 29 ix 1984 (KB); *Ibaraki-ken* - 1 ♀, Mt. Mamizo, 31 viii 1975 (SY), 1 ♀, Tsuchiura, 9 viii 1987 (SKY); *Chiba-ken* - 1 ♂, Abiko, 10 v 1975 (SY); *Nagano-ken* - 1 ♂, Minamiminowa, Ina, 6 vi 1982 (YM); *Gifu-ken* - 1 ♀, Oyama, Seki, 2 x 1977 (Y. Takai); *Fukui-ken* - 1 ♀, Ôno, 30 v 1973 (YH); *Ôsaka-fu* - 1 ♀, Kimi-tôge, 15 vi 1975; *Kyôto-fu* - 1 ♂, Shingoji, Takao, 27 vii 1965 (M. Iwata); *Shimane-ken* - 1 ♀, Mt. Sambe, 28 viii 1982 (YM), 1 ♀, Mt. Hoshigami, 28 viii 1985 (M. Goubara).

Shikoku: *Kôchi-ken* - 1 ♀, Uranouchi, 17 viii 1933 (Y. Sugihara), 1 ♂, Monobe, Nankoku, 18 iv 1975 (SI), 2 ♂ ♂, Godaisan, Kôchi-shi, 7 v 1955 (SI); *Ehime-ken* - 1 ♂, Matsuyama, 10 viii 1969 (HI); *Tokushima-ken* - 1 ♀, Tsudayama, Tokushima-shi, 28 vii 1964 (H. Iwasaki).

Kyûshû: *Nagasaki-ken* - 1 ♀, Haraguchi, Ômura, 27 viii 1966 (R. Ohgushi), 1 ♀, same loc., 7 ix 1966 (R. Ohgushi); *Kagoshima-ken* - 1 ♂, Iriki, 6 ix 1984 (AN), 1 ♀, Kurino, 18 v 1986 (K. Nakamine), 1 ♂, Shiroyama, Kagoshima-shi, 30 vii 1981 (SKY), 1 ♂, Kôrimoto, Kagoshima-shi, 17 viii 1981 (SKY), 2 ♂ ♂, Kanoya, 8-15 ix 1981 (SI), 1 ♀, Sata, 10 vi 1979 (H. Nagase), 2 ♂ ♂, Ônakano, Sata, 10 x 1978 (H. Nagase), 3 ♂ ♂, Sata, 3-4 v 1988 (SKY).

Tsushima Is. (Nagasaki-ken): *Kami-agata* - 1 ♀, Sasuna, 17 ix 1977 (Tominaga), 4 ♂ ♂, Ôboshi-yama, 24 vii 1979 (A. Seino); *Shimo-agata* - 2 ♂ ♂, Izuhara, 27 vii 1986 (K. Nakamine).

Naga-shima Is. (Kagoshima-ken): *Naga-shima* - 3 ♂ ♂ 1 ♀, Shoura, 27 viii 1984 (SKY).

Koshiki-jima Is. (Kagoshima-ken): *Kamikoshiki-jima* - 1 ♀, 6 ix 1984 (M. Maegata).

N. Ryukyus: *Take-shima* - 1 ♀, 3-5 vi 1982 (KT); *Iô-jima* - 1 ♂, 1-3 vi 1982 (SKY), 2 ♂ ♂, 19-22 v 1983 (SKY); *Kuro-shima* - 40 ♂ ♂ 15 ♀ ♀, Ôsato, 31 viii - 5 ix 1981 (SKY); *Tane-ga-shima* - 1 ♂, Hamada, 11 vii 1983

(SKY), 2 ♂♂, Kaminaka, 11 vii 1983 (SKY), 1 ♂, Kamome, 5 viii 1986 (M. Tatsuno); *Yaku-shima* - 1 ♀, Koseta, 30 x 1972 (K. Kusigemati), 8 ♂♂ 10 ♀♀, Miyanoura, 8-11 viii 1981 (SKY), 21 ♂♂ 2 ♀♀, Shitogo, 10 viii 1981 (SKY), 1 ♀, Onoaida, 9 viii 1981 (SKY).

Distribution. Hokkaidô; Honshû; Shikoku; Kyûshû; Tsushima Is. (Kami-agata; Shimo-agata); Naga-shima Is. (Naga-shima); Koshiki-jima Is. (Kamikoshiki-jima); Ôsumi Is. (Take-shima; Iô-jima; Kuro-shima; Tane-ga-shima; Yaku-shima). Other subspecies are known from northern China and Taiwan (Gusenleitner, 1981).

Biology. The female wasp hunts for tortricid larvae (Yukinari, pers. comm.). See also under *S. frauenfeldi*.

Parasite: *Pseudoxenos minor*.

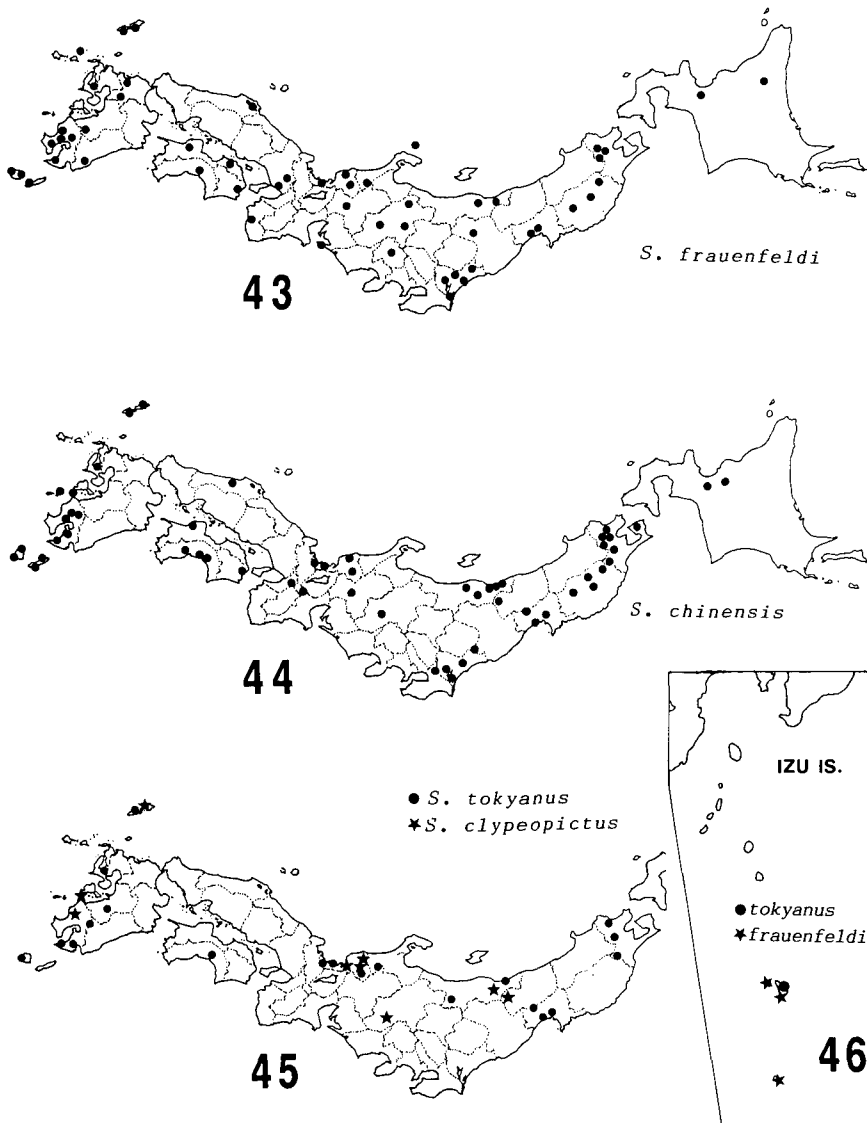

Figs. 43-46. Distribution of *Stenodynerus* species on the Japanese mainlands and Izu Islands.

Ogasawaraensis group

Stenodynerus ogasawaraensis Sk. Yamane et Gusenleitner
(Figs. 5-7, 38, 54)

Stenodynerus ogasawaraensis Yamane and Gusenleitner, 1982, Rep. Fac. Sci. Kagoshima Univ. (Earth Sci. Biol.) 15: 126-127 (♀ ♂)(type loc.: Chichi-jima, Ogasawara Is.).

Japanese name: Ogasawara-chibi-dorobachi.

Diagnosis. Body length (h+th+t1+2): 7.0-7.5 mm in ♀, 5.0-5.5 mm in ♂. Fore wing length: 6.5-7.0 mm in ♀, 5.0 mm in ♂. This species is easily distinguished from the Japanese congeners by the female clypeus not distinctly emarginate apically, very faint pits on the anterior vertical face of pronotum, superficial punctation on mesopleuron and propodeum laterally, and peculiar color pattern.

This species is endemic to the Ogasawara (Bonin) Islands, and at present two color forms are known from Chichi-jima and Haha-jima. The phylogenetic position of this species is not clear, but in structure this species has some character conditions shared by the *frauenfeldi* group as follows: pronotal carina weak but clearly visible over whole length except in the middle, propodeal shelf short but present, and anterior vertical face of gastral tergite 1 not demarcated from the posterior horizontal portion. In this respect the following female specimen from Chichi-jima (Ômura, 16 v 1972, Y. Kusui leg.) is very

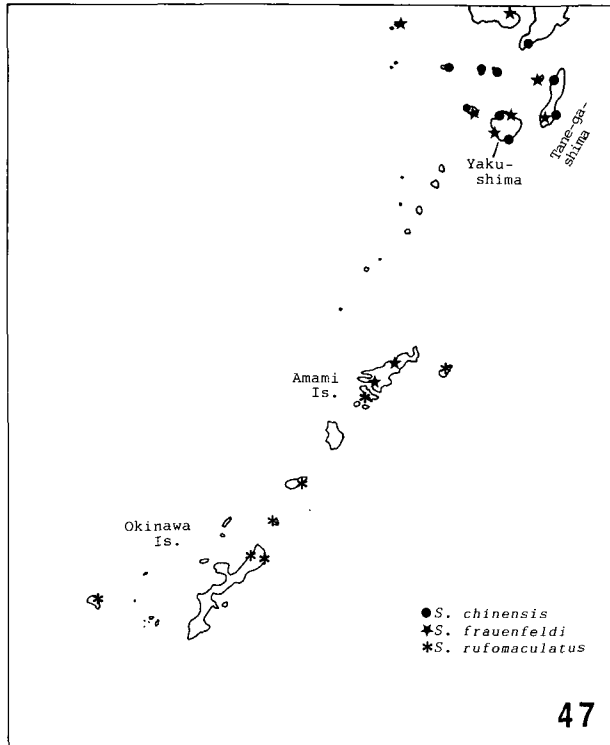

Fig. 47. Distribution of *Stenodynerus* species in the N. and C. Ryukyus.

interesting, because it retains some character conditions that are seen in *S. frauenfeldi* as follows: punctation on mesosoma especially on mesopleuron rather coarse, clypeus apically emarginate, anterior vertical face of pronotum with weak but discernible transverse striae in its upper portion, occipital carina with a distinct angle at some distance from mandible; color pattern as in the typical nominate form of *S. ogasawaraensis*. I consider this individual to represent an extreme variation of *ogasawaraensis* approaching *frauenfeldi* in phenotype.

Nesting biology is not known.

Stenodynerus ogasawaraensis ogasawaraensis Sk. Yamane et Gusenleitner

Diagnosis. Female. Black; the following parts yellow: clypeus (sometimes with a blackish marking at apex), a small basal marking on mandible, minute spot on temple, antennal scape below (yellow often reduced or replaced by reddish brown), pronotum largely, tegula largely, parategula, dorsal mesepisternum wholly, a longitudinal marking on ventral mesepisternum (often reduced), a pair of very large markings on propodeum, narrow apical band on gastral tergite 1, wider apical bands on tergite 2 and sternite 2, coxae of all legs, femora of all legs (hind femur with extensive black area), tibiae of all legs. Yellow apical bands on tergites 1, 2 and sternite 2 sometimes obscure. Mandible largely brownish, slightly tinged with yellow. Gastral segments 1 and 2 wholly rufous except for yellow apical bands. Tarsi of all legs blackish brown.

Male. Very similar to the female in coloration, differing therefrom as follows: clypeus wholly yellow, mandible yellow except for teeth, antennal scape below extensively yellow, yellow marking on ventral mesepisternum absent, lower half of lateral part of propodeum rufous, gastral tergite 3 with a narrow yellow apical band.

Material examined. Ogasawara Is. (Tôkyô-to): *Chichi-jima* - 1 ♀, Ômura, 16 v 1972 (Y. Kusui), 1 ♀, Tsutsuji-yama, 2 vi 1972 (Y. Kusui), 1 ♀, same loc., 12 vii 1972 (Y. Kusui), 1 ♂1 ♀, 17 viii 1972 (YH)(including the holotype female), 1 ♀, 9 vi 1974 (T. Nakane), 3 ♀ ♀, Chûô-san, 9-13 viii 1983 (TN); *Haha-jima* - 1 ♀, 13-26 viii 1980 (H. Kurahashi).

Distribution. Ogasawara (Bonin) Is. (*Chichi-jima*; *Haha-jima*).

Stenodynerus ogasawaraensis rufoornatus Sk. Yamane

Stenodynerus ogasawaraensis rufoornatus: Yamane and Tano, 1987, Trans. Shikoku Entomol. Soc. 18: 332 (♀ ♂)(type loc.: *Haha-jima*, Ogasawara Is.).

Diagnosis. Female. In structure and coloration similar to the nominotypical subspecies, but much more melanic especially in alitrunk and legs: clypeus black below, yellow spot on mandible much reduced, yellow pronotal band less extensive, pronotal tubercle black, yellow marking on scutellum much reduced, yellow markings on fore and mid femora less developed, hind femur and tibia wholly blackish brown.

Male. Similar to the female, with the following differences: clypeus wholly yellow, scutellum without yellow marking, tegula divided by a wide blackish bar into upper and lower portions, legs more extensively marked with yellow.

Material examined. Ogasawara Is. (Tôkyô-to): *Haha-jima* - 1 ♂, Nagahama, 11 viii 1983 (TN) (holotype), 1 ♂1 ♀, Kitakoo, 11 viii 1983 (TN); *Mukô-jima* - 1 ♂, 23 v 1973 (Y. Kusui).

Distribution. Ogasawara (Bonin) Is. (Haha-jima; Mukô-jima).

Taxonomic notes. This form, restricted to the Haha-jima group, is not distinguished in structure from the nominotypical form and may represent a geographical race or subspecies. However, as already stated, one female of the nominotypical form was captured from Haha-jima. If the occurrence of the nominotypical form on the island is not accidental, the relationship of the two forms may be open to criticism.

Clypeopictus group

Stenodynerus clypeopictus (Kostylev)

(Figs. 35, 42, 45, 53)

Odynerus japonicus Matsumura, 1926, Ins. Matsum. 1: 37, pl. 3, fig. 12 (nec. 11) (♂) (homonym of *Odynerus japonicus* Schulthess, 1908)(type loc.: Nago, Okinawa-jima).

Odynerus clypeopictus Kostylev, 1940, Bull. Soc. Nat. Moscou, Sect. Biol. (N.S.), 49: 28 (♀)(type loc.: Semiretchie, Kazakh, USSR).

Stenodynerus chinensis: Vecht and Fischer, 1972, Hym. Cat. (nov. ed.), p. 65 (from Okinawa); Gusenleitner, 1981, Polsk. Pismo Entomol. 51: 289-291 (from Okinawa).

Stenodynerus clypeopictus: Yamane and Gusenleitner, 1982, Rep. Fac. Sci. Kagoshima Univ. (Earth Sci. Biol.), 15: 121-122, fig. 16.

Japanese name: Futokagi-chibi-dorobachi.

Diagnosis. Body length (h+th+t1+2): 7.0-7.5 mm in ♀, 5.0-6.0 mm in ♂. Fore wing length: 5.5-6.0 mm in ♀, 4.0-5.0 mm in ♂. The female of this species is similar to that of *S. frauenfeldi* in structure and coloration, but in the former the punctation on clypeus and gastral tergites is much finer and the legs are more richly marked with yellow than in the latter. The male is very distinctive in the last antennal segment (hook) not tapering apically; antennal segment 11 ventrally slightly concave to receive the hook (Fig. 35).

Female. Black, with the following parts yellow: apical 1/3 to 1/2 of clypeus, frontal spot, minute spot on temple, a triangular marking on mandibular base, antennal scape below (sometimes reduced to lines), a pair of spots on pronotum anteriorly, outer margin of tegula, dorsal mesepisternum largely, metanotum largely, narrow apical bands on tergites 1 and 2, and also on sternite 2, apical part of fore (and sometimes also mid) femur, tibiae of all legs extensively.

Male. Yellow markings on alitrunk and gaster as in ♀. Head and legs with yellow as follows: clypeus largely, labrum wholly, frontal spot, minute spot on temple, a line on each innerorbit, mandible largely, antennal scape below, anterior face of mid (often also fore and hind) coxa, apical parts of all femora, tibiae and tarsi of all legs (apical parts of tarsi including tarsal claws often brownish). Apical half of antennal hook yellowish or ferruginous.

Material examined. Hokkaidô: 2 ♂♂, Momiji-yama, Ishikari, 5 viii 1968 (TN).

Honshû: *Yamagata-ken* - 1 ♂, Nukumi, Oguni, 28 ix 1980 (HI); *Niigata-ken* - 3 ♂♂, Fukushima-gata, Toyoura, 14 ix 1980 (HI); *Nagano-ken* - 1 ♂, Minamiminowa, Ina, 29 v 1963 (YM); *Fukui-ken* - 1 ♀, Ôno, 15 ix 1971 (YH), 1 ♂, same loc., 23 vii 1973 (YH).

Kyûshû: *Kagoshima-ken* - 1 ♀, Higashi-ichiki, 23 ix 1978 (SI).

Tsushima Is. (Nagasaki-ken): *Kami-agata* - 1 ♂, Nii, Toyotama-son, 20 viii 1968 (I. Hiura).

Naga-shima (Kagoshima-ken): 1 ♀, Shoura, 27 viii 1984 (SKY).

C. Ryukyus: *Okinawa-jima* - 2 ♂♂, viii 1905 (Kuroiwa)(type series of *Odynerus japonicus* Matsumura), 1

♂, Naha, 29 v 1984 (SKY), 1 ♂, same loc., 12 iv 1985 (SKY).

Distribution. Hokkaidô; Honshû; Kyûshû; Tsushima Is. (Kami-agata); Naga-shima; Okinawa Is. (Okinawa-jima). Palearctic.

Taxonomic notes. I have compared the Japanese specimens with one male and one female from France (sent by Dr. J. Gusenleitner). There are no remarkable difference in color pattern between them. In the male specimens from Okinawa-jima the yellow markings on pronotum are slightly larger and the anterior faces of fore and hind coxae are more often marked with yellow than in those from the Japanese mainlands. However, all these specimens cannot be divided into distinct forms. It seems that this species is little variable in basic color pattern throughout its wide geographical range.

Biology. No information is available both in Japan and Europe.

Tokyanus group

Stenodynerus tokyanus (Kostylev)

(Figs. 36, 45, 46, 55-57)

Odynerus (*Nannodynerus*) *tokyanus* Kostylev, 1940, Bull. Soc. Nat. Moscou, Sect. Biol. (N.S.), 49 (5/6): 28 (♀)(type loc.: Tôkyô, Honshû).

Stenodynerus tokyanus: Vecht and Fischer, 1972, Hym. Cat. (nov. ed.), 8: 69; Gusenleitner, 1981, Polsk. Pismo Entomol. 51: 291-294, fig. 67.

Japanese name: Munaguro-chibi-dorabachi.

Diagnosis. Body length (h+th+t1+2): 7.0-8.5 mm in ♀, 6.5-7.5 mm in ♂. Fore wing length: 7.0-8.0 mm in ♀, 6.0-7.0 mm in ♂. This species is easily distinguished from the congeners inhabiting the Japanese mainlands by the larger body, almost complete lack of propodeal shelf, and well demarcated anterior vertical face of gastral tergite 1. The anterior face of tergite has only a few scattered punctures and a vertical keel that is somewhat obscure in ♂. Male antennal segments 8-11 very thick; segments 12 and 13 (hook) small; hook rather sharply pointed at apex (Fig. 36).

This species has a close relative, *S. kusigematii*, in the Ryukyus, but none out of Japan. Gusenleitner (1981) placed *S. tokyanus* under "Gruppenzugehörigkeit nicht geklärt". In Japan two geographical races are recognized.

Nesting biology is not known.

Stenodynerus tokyanus tokyanus (Kostylev)

(Figs. 45, 55)

Stenodynerus tokyanus tokyanus: Yamane and Gusenleitner, 1982, Rep. Fac. Sci. Kagoshima Univ. (Earth Sci. Biol.), 15: 122-123, fig. 10.

Japanese name: Munaguro-chibi-dorobachi.

Diagnosis. Female. Black, with the following parts yellow: frontal spot, antennal scape below (tinged with red), minute spot on temple, a pair of spots or lines on pronotum anteriorly (often lost), parategula (often ferruginous), a large spot on dorsal mesepisternum, metanotum (often wholly black), apical bands on gastral tergites 1, 2 and

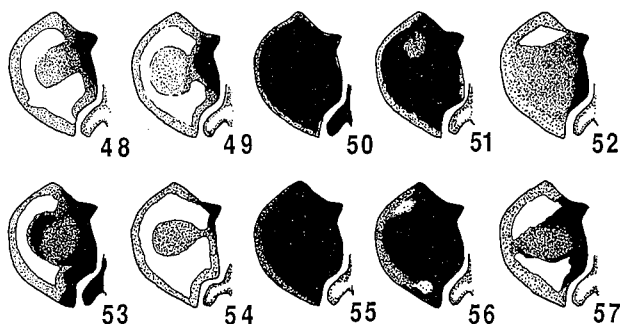

Figs. 48-57. Color pattern of tegula and parategula in the Japanese *Stenodynerus*. 48, *frauenfeldi*; 49, *rufomaculatus*; 50-52, *chinensis similimus*; 53, *clypeopictus*; 54, *ogasawaraensis*; 55, 56, *tokyanus tokyanus*; 57, *t. flavoscutellatus*.

sternite 2, anterior face of fore tibia. Apical 4 or 5 antennal segments below and apical 2/3 of mandible ferruginous. Tegula dark ferruginous. Legs largely blackish brown.

Male. In addition to the yellow markings seen in ♀, the following parts yellow: clypeus largely, mesal portion of mandible largely, anterior faces of mid and hind coxae (sometimes wholly black), anterior face of mid tibia.

Material examined. Honshū: *Miyagi-ken* - 1 ♀, Rifu, 8 x 1980 (K. Goukon); *Niigata-ken* - 2 ♀ ♀, Mikunitōge, 6 ix 1981 (KB), 2 ♀ ♀, Senami, 1-11 x 1984 (KB); *Ishikawa-ken* - 1 ♀, Mt. Haku, Chūgū Spa, 17 viii 1973 (I. Togashi); *Fukui-ken* - 1 ♀, Nakajima, Ōno, 24 vii 1956 (YH), 1 ♀, Asahi, Ōno, 10 viii 1957 (YH), 1 ♂, same loc., 20 vi 1963 (YH), 1 ♀, Shimojime, Ōno, 12 ix 1963 (YH), 1 ♀, Asahi, Ōno, 4 viii 1966 (YH).

Shikoku: *Kōchi-ken* - 1 ♀, Engyōji, Kōchi-shi, 19 ix 1933 (Y. Sugihara), 1 ♂, Kōchi, 23 v 1935 (K. Oike).

Kyūshū: *Nagasaki-ken* - 1 ♀, Haraguchi, Ōmura, 1 x 1967 (R. Ohgushi); *Kagoshima-ken* - 1 ♂, Takachiho-mine, Kirishima, 31 vii 1972 (K. Kusigemati).

Tsushima Is.: *Shimo-agata* - 1 ♀, Shira-dake, 22 vii 1978 (K. Tani).

N. Ryukyus: *Yaku-shima* - 1 ♀, Kurio - Ōko, 5 x 1981 (Y. Takai).

Distribution. Honshū; Shikoku; Kyūshū; Tsushima Is. (Shimo-agata); Ōsumi Is. (Yaku-shima).

Stenodynerus tokyanus flavoscutellatus Sk. Yamane et Gusenleitner
(Figs. 46, 57)

Stenodynerus tokyanus flavoscutellatus Yamane and Gusenleitner, 1982, Rep. Fac. Sci. Kagoshima Univ. (Earth Sci. Biol.), 15: 123 (♀ ♂)(type loc.: Hachijō-jima, Izu Is.).

Japanese name: Hachijō-chibi-dorobachi.

Diagnosis. Female. Black; the following parts yellow or orange yellow: a basal band on clypeus, frontal spot, spot on temple, antennal scape below, a wide band on pronotum anteriorly, anterior and posterior marking on tegula, parategula, dorsal mesepisternum largely, a small spot on ventral mesepisternum (often lost), a pair of large spots on scutellum, metanotum largely, inferior ridge of propodeum, a rather wide apical band on gastral tergite 1 (the band with an anterior prong on each side), a slightly narrower apical band on tergite 2, a still narrower band on sternite 2, lines on fore and mid femora apically, outer faces of all tibiae extensively. Mandible dark ferruginous. 2-3 terminal

segments of antenna ferruginous below.

Male. Very similar to the female in coloration. Head more extensively marked with yellow as follows: clypeus largely, mesal portion of mandible, a short line and a minute spot along the inner margin of eye below. Scutellum almost wholly black.

Material examined. Izu Is. (Tôkyô-to): *Hachijô-jima* - 1 ♀, Okagou - Fuji, 26 v 1964 (Y. Hirashima & M. Shiga)(holotype), 1 ♂, Kamogawa, 27 v 1964 (Y. Hirashima & M. Shiga), 1 ♀, Mitsune - Kantoyama, 30 v 1964 (Y. Hirashima & M. Shiga), 2 ♀ ♀, Mitsune - Eigou, 24-30 viii 1987 (H. Takahashi).

Distribution. Izu Is. (Hachijô-jima).

Stenodynerus kusigematii Sk. Yamane et Gusenleitner

(Figs. 31, 37, 58-61)

Stenodynerus kusigematii Sk. Yamane and Gusenleitner, 1982, Rep. Fac. Sci. Kagoshima Univ. (Earth Sci. Biol.) 15: 123-125 (♀)(type loc.: Okinawa-jima); Yamane and Tano, 1987, Trans. Shikoku Entomol. Soc. 18: 329-332, figs. 1-4.

Stenodynerus yambarah Yamane and Gusenleitner, 1982, Rep. Fac. Sci. Kagoshima Univ. (Earth Sci. Biol.) 15: 125-126 (♂) (type loc.: Okinawa-jima). *Syn. nov.*

Japanese name: Minami-chibi-dorobachi.

Diagnosis. Body length (h+th+t1+2): 7.0-7.5 mm in ♀, 6.0-6.5 mm in ♂. Fore wing length: 6.0-7.0 mm in ♀, 5.5-6.5 mm in ♂. Structurally this species is distinguished from the closely related *S. tokyanus* in the following points: clypeus nearly as wide as high, punctation on the vertical face of pronotum much finer and sparser than in *tokyanus*, punctures on the posterior horizontal part of pronotum and mesoscutum smaller and often as large as or smaller than interspaces, abscissa 4 of fore wing much longer than abscissa 5. In coloration all the subspecies so far known of this species are much more richly marked with yellow or orange yellow.

This species is at present known only from the Central and Southern Ryukyus, comprising several subspecies. It is not common on any island. Ishigaki-jima and Iriomote-jima seem to lack it.

Biology is not known in any subspecies.

Key to the subspecies of *Stenodynerus kusigematii* (♀)

1. Gastral tergite 2 laterally with a pair of yellow spots. Ocular sinus extensively yellow. Yonaguni-jima. subsp. *pachymenoides* Tano
- Gastral tergite 2 without such spots. Ocular sinus at most with a yellow spot. 2
2. Gastral sternites 1 and 2 extensively rufous. Tokuno-shima. subsp. *rufiventris* Yam.
- Gastral sternites 1 and 2 black. 3
3. Clypeus black in lower 2/3. Ocular sinus without yellow spot. Scutellum and propodeum without yellow markings. Amami-ôshima. subsp. *tsunekii* Tano
- Clypeus at most with a blackish bar in lower portion. Ocular sinus often with a small yellow spot. Scutellum almost wholly yellow. Propodeum laterally with a pair of large markings. Okinawa-jima. subsp. *kusigematii* Yam. et Gusnlt.

Stenodynerus kusigematii tsunekii Tano
(Fig. 58)

Stenodynerus kusigematii tsunekii: Yamane and Tano, 1987, Trans. Shikoku Entomol. Soc. 18: 329-330, fig. 1 (♀)(type loc.: Amami-ôshima).

Diagnosis. Female. Black, the following parts yellow or orange yellow: clypeus in upper 1/3, frontal spot, spot on temple, a line at mandibular base along mesal margin, antennal scape below, a pair of large markings on pronotum anteriorly, tegula largely, parategula, a large spot on dorsal mesepisternum, metanotum wholly, relatively wide band on gastral tergite 1 (laterally dilated), slightly narrower apical band on tergite 2, still narrower apical band on sternite 2, femora of all legs except in basal parts, tibiae of all legs. Apical 3 segments of antenna below rufous. Apical half of mandible dark ferruginous. Tarsi of all legs brownish.

Male unknown.

Material examined. C. Ryukyus: Amami-ôshima - 1 ♀, 26 vi 1961 (K. Tsuneki) (holotype).

Distribution. Amami Is. (Amami-ôshima).

Stenodynerus kusigematii rufiventris Sk. Yamane
(Fig. 59)

Stenodynerus kusigematii rufiventris: Yamane and Tano, 1987, Trans. Shikoku Entomol. Soc. 18: 330, fig. 2 (♀)(type loc.: Tokuno-shima, Amami Is).

Diagnosis. Female. Black, with yellow and rufous markings. Yellow are: clypeus (with a brown stripe in its lower portion), a wedge-shaped marking on frons, spot on temple, mandible largely (tinged with brown), antennal scape below, a pair of large markings on pronotum anteriorly, tegula largely, parategula, dorsal mesepisternum wholly, metanotum nearly wholly, a pair of large markings on propodeum laterally, wide apical band on gastral tergite 1, slightly narrower apical band on tergite 2, still narrower and sinuated apical band on sternite 2, anterior face of mid coxa, fore and mid femora, tibiae of all legs. Several apical segments of antenna below ferruginous. Horizontal portion of tergite 1 except in the middle, sternites 1 and 2 rufous. Trochanters and tarsi of all legs brownish.

Male unknown.

Material examined. C. Ryukyus: Tokuno-shima - 1 ♀, Kametsu, 13 vii 1983 (T. Moriyama) (holotype).

Distribution. Amami Is. (Tokuno-shima).

Stenodynerus kusigematii subsp. ?

Stenodynerus kusigematii subsp.: Yamane and Tano, 1987, Trans. Shikoku Entomol. Soc. 18: 330.

Diagnosis. Male. Black; the following parts orange yellow or yellow: clypeus wholly (yellow), mandible (yellow) except for apex (ferruginous) and basal marking (black), antennal scape except for apical 1/3 of upper face black, frontal spot, small spot on temple, wide anterior band on pronotum (medially narrowed), dorsal mesepisternum largely, tegula, parategula, a transverse marking on scutellum, metanotum wholly, very

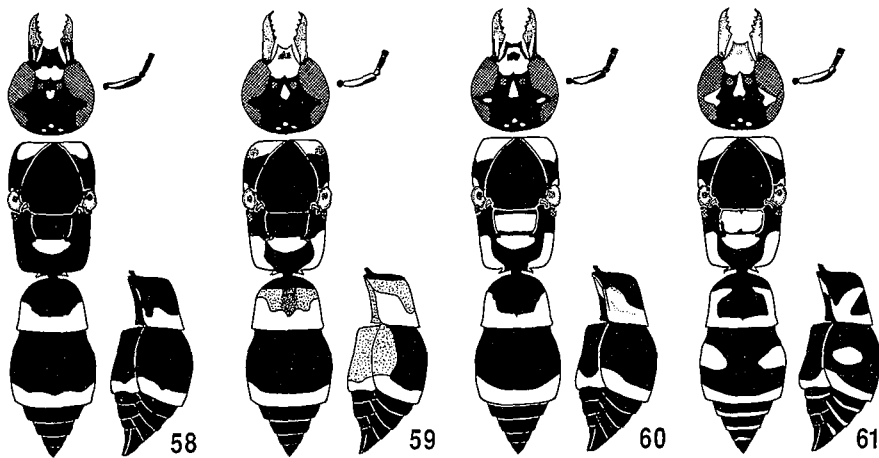

Figs. 58-61. Body color pattern in the four subspecies of *Stenodynerus kusigematii* (after Yamane & Tano, 1987). 58, ssp. *tsunekii* (Amami-oshima); 59, ssp. *rufiventris* (Tokuno-shima); 60, ssp. *kusigematii* (Okinawa-jima); 61, ssp. *pachymenoides* (Yonaguni-jima).

wide apical band on gastral tergite 1, apical bands on tergite 2 and sternite 2, fore and mid legs except for coxae, apical 1/3 of hind femur, hind tibia and tarsus wholly. Terminal segments of antenna below ferruginous.

Female unknown.

Material examined. C. Ryukyus: Okinoerabu-jima - 1 ♂, Oyama, 21 iii 1964 (T. Iida).

Stenodynerus kusigematii kusigematii Sk. Yamane et Gusenleitner
(Fig. 60)

Stenodynerus yambarah Yamane and Gusenleitner, 1982 [see under *S. kusigematii*].

Japanese name: Minami-chibi-dorobachi.

Diagnosis. Female. Black, with the following parts yellow or lemon yellow: clypeus (sometimes with a transverse black marking), wedge-shaped frontal marking, a relatively large spot on temple, a minute spot on ocular sinus (often lost), mandible except for apical part (brownish) and basal triangular marking (black), antennal scape except for apical 2/3 of its upper face, wide pronotal band medially narrowed, tegula largely, parategula, dorsal mesepisternum wholly, scutellum and metanotum almost wholly, a pair of large markings on propodeum laterally, wide apical band on tergite 1 (laterally much dilated), apical band on tergite 2 (laterally slightly dilated), an incomplete apical band on tergite 3, sternite 1 except medially, narrow apical band on sternite 2 (medially widened), an incomplete apical band on sternite 3, anterior face of mid coxa, fore and mid femora, tibiae of all legs. Apical 3 segments of antenna below dark orange. Tarsi of all legs blackish.

Male. The original description of the male of *S. yambarah* is reproduced below. Black, with the following parts yellow: clypeus wholly, mandible largely, frontal marking (in one specimen, produced below), minute spot on temple, antennal scape below, wide band on

pronotum anteriorly, a marking on dorsal mesepisternum, tegula posteriorly, parategula, metanotum wholly, apical bands on gastral tergites 1, 2 and sternite 2, incomplete band on sternite 3 (in one specimen also on 4), anterior face of mid coxa, tibiae of all legs.

Material examined. C. Ryukyus: *Okinawa-jima* - 2 ♂♂, Hedo, Kunigami, 5 iv 1979 (K. Ohara) (including the holotype of *S. yamabara*), 1 ♀, Benoki, Kunigami, 7 iv 1979 (K. Kusigemati) (holotype), 1 ♀, Oku, Kunigami, 5 viii 1982 (YH), 1 ♀, Hentona, 1 vi 1983 (AN), 1 ♀, Yona, 2 vi 1983 (AN), 1 ♀, Hentona, 5 x 1987 (AN).

Distribution. Okinawa Is. (northern parts of Okinawa-jima).

Stenodynerus kusigematii pachymenoides Tano
(Fig. 61)

Stenodynerus kusigematii pachymenoides: Yamane and Tano, 1987, Trans. Shikoku Entomol. Soc. 18: 330-332, fig. 4 (♀♂) (type loc.: Yonaguni-jima, Yaeyama Is.).

Diagnosis. Female. In structure similar to the nominotypical subspecies, but the anterior vertical face of pronotum virtually with no punctures except for the pair of pits near neck.

Black (ground color of gastral tergites tinged with brown), with the following parts vivid yellow: clypeus wholly, mandible largely, frontal marking produced so as to reach upper margin of clypeus, ocular sinus, a long stripe behind eye, antennal scape below, wide pronotal band medially narrowed, dorsal mesepisternum largely, a small spot or spots on ventral mesepisternum, tegula except for center and margins, parategula, scutellum and metanotum nearly wholly, a pair of large markings on propodeum dorsolaterally, apical bands on gastral tergites 1-4 (that on tergite 1 with an anterior prong on each side), a pair of spots on tergite 2, sinuated apical bands on sternites 2 and 3 (4), a pair of spots on sternite 2, anterior face of fore and mid coxae, apical 2/3 of fore and mid femora, tibiae of all legs (partly brownish). Antenna ferruginous below.

Male. Very similar to the female. The two specimens examined lack the small yellow spot(s) on ventral mesepisternum, and yellow spots on sternite 2.

Material examined. S. Ryukyus: *Yonaguni-jima* - 2 ♂♂ 1 ♀, Kubura, 24 vii 1984 (C. Nozaka), 2 ♀♀, Urabu, 10 viii 1985 (TM) (including holotype).

Distribution. Yaeyama Is. (Yonaguni-jima).

Genus *Allodynerus* Blüthgen

Allodynerus Blüthgen, 1938, Konowia 16 (1937): 280 (as subgenus of "*Euodynerus* Blüthgen") (type species: *Odynerus floricola* Saussure, 1853, original designation); 1938, Dt. Ent. Zeitschr. 1938: 452, 458 (as genus); 1953, Zool. Anz. 150: 50 (as genus); 1961, Faltenwespen Mitteleuropas, p. 69 (as genus, in key).

Japanese name: Kita-dorobachi Zoku.

The wasps of this genus are medium-sized, measuring 8-12 mm in total length. Head and thorax bears golden pubescence. Clypeus is wider than high. The depression for cephalic fovea (♀) is large, kidney-shaped and posteriorly with a single fovea. Antennal hook (♂) is developed, reaching the apex or middle of segment 10 (Figs. 64, 65). Thorax is relatively short; whole mesoscutum and scutellum are punctate. Tegula is narrow and

long, with its posterior lobe well developed, extending beyond the posterior end of parategula (Figs. 66, 67). Posterior face of hind coxa possesses a keel which is obtuse in profile. Propodeum has no shelf; superior carina of propodeum is only weakly developed or almost absent. Gastral segment 1 is narrower than 2, tergite 1 being wider than long and without transverse carina.

Only two species occur in Japan (Giordani Soika, 1986; Yamane & Tano, 1987), while seven other species have been known from the Palearctic region (Vecht & Fischer, 1972).

Allodynerus delphinalis delphinalis (Giraud)
(Figs. 62-64, 66, 68-70, 72)

Odynerus (Leionotus) delphinalis Giraud, 1866, Ann. Soc. Ent. Fr. (4)6: 464 (♀)(type loc.: Grenoble, France).

Allodynerus delphinalis delphinalis: Blüthgen, 1953, Zool. Anz. 150: 53-54; 1961, Faltenwespen Mitteleuropas, pp. 126-132; Yamane & Tano, 1987, Trans. Shikoku Entomol. Soc. 18: 342-343, figs. 10, 11.

Allodynerus sp.: Yamane, 1982, Trans. Essa Entomol. Soc. 53: 5; Hisamatsu et al. 1986, Bull. Fac. Educ. Ibaraki Univ. (Nat. Sci.) 35: 59-60, figs. 17, 29, 48, 60, 80.

Japanese names: Atoboshi-kita-dorobachi (Kita-dorobachi).

Diagnosis. Female. Body length (h+th+t1+2): 7.0-10.0 mm. Fore wing length: 7.5-9.0 mm. Head distinctly wider than high ($W/H = 1.17$), densely punctate. Hairs on head distinctly longer than those on thorax. Clypeus much wider than high, triangular, anteriorly weakly emarginate (Fig. 62). Interantennal keel distinct. Ocellar triangle flat; distance between posterior ocelli only slightly longer than ocello-ocular distance. Depression for cephalic fovea large, wider than distance between posterior ocelli, with a transverse carina just behind the fovea. Hairs on antennal scape microscopic. Thorax densely punctate; anteroventral portion of mesepisternum partly impunctate; upper metapleuron striate. Superior ridge of propodeum weak, but distinct edge present; propodeal groove with a vertical carina; sides of propodeum only weakly reticulate in upper portion. Gastral segments 3-6 much narrower than segment 2. Gastral tergites 1-3 densely punctate; punctuation stronger on tergite 1 than on 2; apical margin of tergite 2 rarely slightly reflexed, often weakly denticulate; preapical depression on tergite 2 weak (Fig. 68). Gastral sternite 1 reticulate; basal area of sternite 2 with ca. 15 vertical carinae; punctuation on this sternite similar to that on tergite 2; last tergite and sternite almost impunctate.

Black. Yellow are: clypeus with a median black marking, a transverse frontal marking, a stripe on inner orbit just above clypeus, a stripe behind eye, basal half of mandible largely, scape below, an anterior pronotal band, a spot on dorsal mesepisternum, an irregular marking on scutellum (often lost), metanotum wholly, tegula with a central semi-transparent part, a large marking on each side of dorsal face of propodeum, an apical bands on gastral tergites 1-5 (band on tergite 2 widest), apical spot on tergite 6, an apical band on sternite 2, apical fourth to third of femora of all legs, tibiae and tarsi of all legs nearly wholly (slightly tinged with brown). Antennal flagellum below ferruginous.

Male. Body length (h+th+t1+2): 6.0-7.5 mm. Fore wing length: 6.5-7.5 mm. Very similar to the female in punctuation and sculpture. Clypeus more deeply emarginate anteriorly (Fig. 63). Distance between posterior ocelli distinctly longer than ocello-ocular distance. Inner faces of antennal segments 10 and 11 with a concavity to receive recurved

segments 12 and 13. Marked with yellow more extensively than in the female. Clypeus and mandible almost wholly yellow. Yellow stripe on inner orbit longer, extending into ocular sinus. Mid coxa wholly yellow. Mesopleuron, metanotum, propodeum and last tergite, however, almost always lacking yellow markings.

Material examined. Hokkaidô: 1 ♂, Abashiri, 2 ix 1954 (K. Kamijo).

Honshû: *Iwate-ken* - 1 ♂, Kuriyagawa, Morioka, 23 vi 1969 (YM), 1 ♂, same loc., 24 vi 1973 (YM), 2 ♂ ♂, Ôshuku, Shizukuishi, 7 viii 1987 (SKY); *Fukushima-ken* - 1 ♀, Bantai-san, Aizu, 4 viii 1927 (S. Matsumura); *Niigata-ken* - 2 ♀ ♀, Shidai-hama, 9 vii 1970 (HI), 1 ♀, Nagaoka, 9 vii 1976 (SKY); *Saitama-ken* - 1 ♂, Kodama, 25 vii 1964 (TN), 1 ♀, same loc., 10 viii 1969 (TN); *Gumma-ken* - 1 ♂, Buson-sanroku, 21 vii 1974 (HI); *Ibaraki-ken* - 1 ♂ 1 ♀, Tsuchiura, 29 viii 1974 (SKY); *Nagano-ken* - 1 ♂, Minamiminowa, Ina, 22 v 1962 (H. Fujii), 1 ♂, same loc., 29 vii 1962 (YM), 2 ♂ ♂, Saku, 28 vii 1974 (YM); *Fukui-ken* - 1 ♂, Ôno, 3 x 1964 (YH); *Ishikawa-ken* - 1 ♂, Komaiko, 4 vii 1976 (H. Kurokawa); *Shimane-ken* - 1 ♂, Nishikawatsu, Matsue, 15 viii 1985 (M. Goubara).

Distribution. Hokkaidô; Honshû. Palearctic.

Taxonomic notes. This species is easily distinguished from all the other species of the Japanese Eumenidae by the possession of both the black oval marking on clypeus and the yellow round marking on tergite 6 in the female (Fig. 69). Although Blüthgen (1961) points out that body markings in European populations greatly vary among specimens, the color

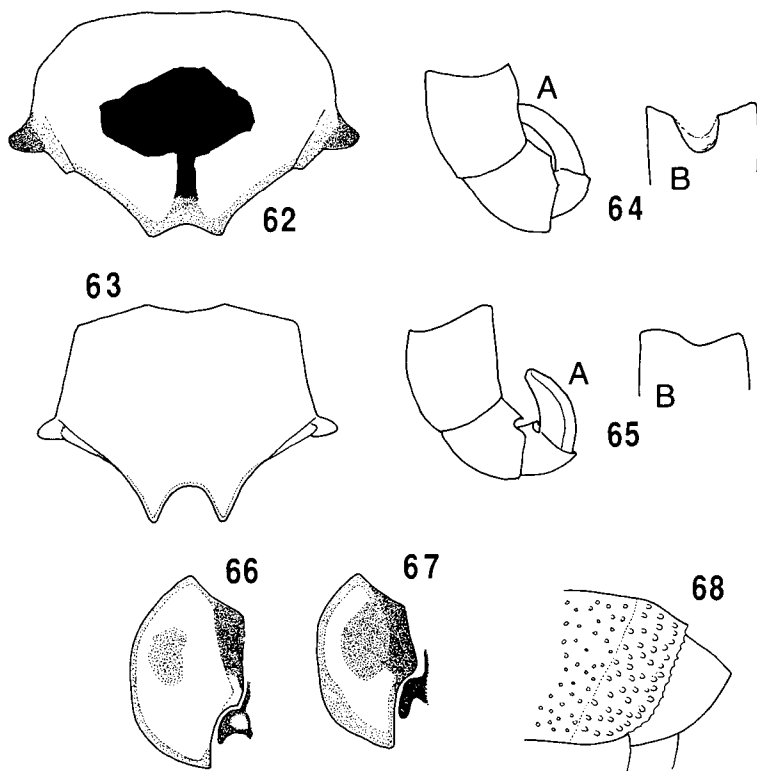

Figs. 62-68. Morphological characters in the Japanese *Allodynerus*. 62-64, 66, 68, *A. delphinalis*; 65, 67, *A. manschuricus*. 62, clypeus (♀); 63, ditto (♂); 64, 65, terminal segments of male antenna (A, profile; B, segment 10 from below); 66, 67, tegula and parategula; 68, apical part of gastral tergite 2 (♀).

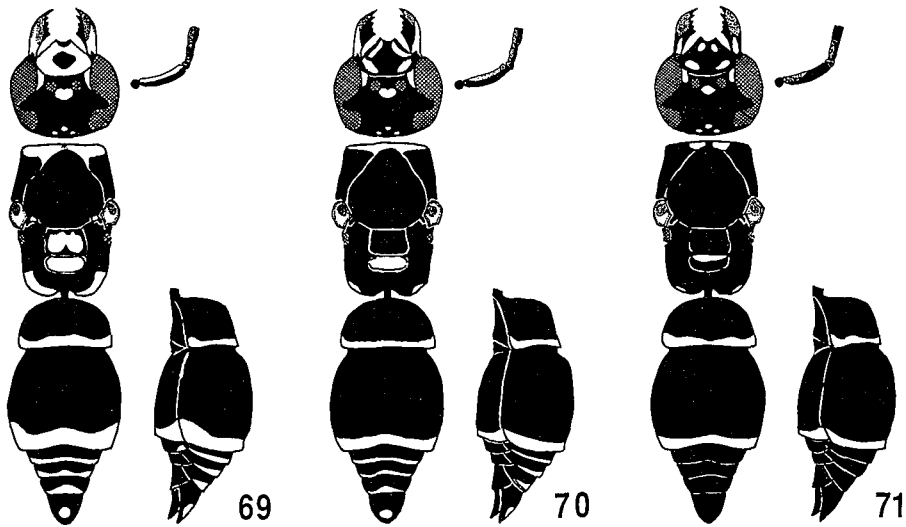

Figs. 69-71. Color pattern of the two Japanese species of *Allodynerus* (after Yamane & Tano, 1987).
69, *A. delphinalis*; 70, melanic individual of *delphinalis*; 71, *A. mandshuricus*.

pattern in the Japanese population is generally stable. However, in a rather melanic female at hand the black clypeal marking is very large, widely connected with black basal and apical margins (Fig. 70).

Biology. The nesting biology in Europe was studied by Enslin (1922). The following description of the nesting behavior of this species is based upon unpublished data amassed by Dr. K. Goukon at Rifu, Miyagi-ken, northern Honshū, during June/July, 1987. This species nests in dead stems of *Miscanthus sinensis* growing in open lands. A few nests were also found from stems of a bramble, *Rubus palmatus* var. *coptophyllus*, the upper portion of which had been cut away in order to induce the small carpenter bee *Ceratina flavipes* to nest. The female wasps most probably take over abandoned nests of *C. flavipes*, but they may excavate by themselves the pith to enlarge the cell. The total number of brood cells constructed in each tube nest varied from 1 to 5 (mean, 2.7; n=12). The first (innermost) cells always contained a female young. A vestibular (empty) cell was constructed in 7 of the 12 completed nests observed. Although the prey were not identified even at family level, larvae of some microlepidopterous species were no doubt involved. It is estimated that 4-8 caterpillars were provisioned for a male-producing cell and 9-15 for a female-producing cell. In two nests the mother wasp was found in her incomplected brood cell together with her medium-sized larva. This suggests the occurrence of progressive provisioning in this species. At least two generations were recognized in 1987.

Parasitoids: *Melittobia* sp. (Hymenoptera, Eulophidae) and two species of parasitic flies.

Allodynerus mandschuricus Blüthgen
(Figs. 65, 67, 71, 72)

Allodynerus mandschuricus Blüthgen, 1953, Zool. Anz. 150 (♀) (type loc.: "Charbin", China): 57-58; Giordani-Soika, 1970, Boll. Soc. Entomol. Ital. 102: 150-151 (♂); 1986, Boll. Mus. Civ. St. Nat. Venez. 35 (1984): 132; Yamane and Tano, 1987, Trans. Shikoku Entomol. Soc. 18: 343-344.

Japanese name: Ajia-kita-dorobachi.

Diagnosis. Femele. Body length (h+th+t1+2): 8.5-9.0 mm. Fore wing length: 7.0-7.5 mm. This species differs from *A. delphinalis* in the following points. Head more round, only slightly wider than high ($W/H = 1.08$). Clypeus slightly longer than in *delphinalis*. Distance between the posterior ocelli longer than that between posterior ocellus and eye. Hairs on antennal scape relatively long. Sides of propodeum distinctly reticulate in upper portion; superior ridge absent. Punctuation on gastral tergites 1 and 2 stronger than in *delphinalis*. Gastral tergite 2 slightly reflexed but with smooth margin apically; preapical

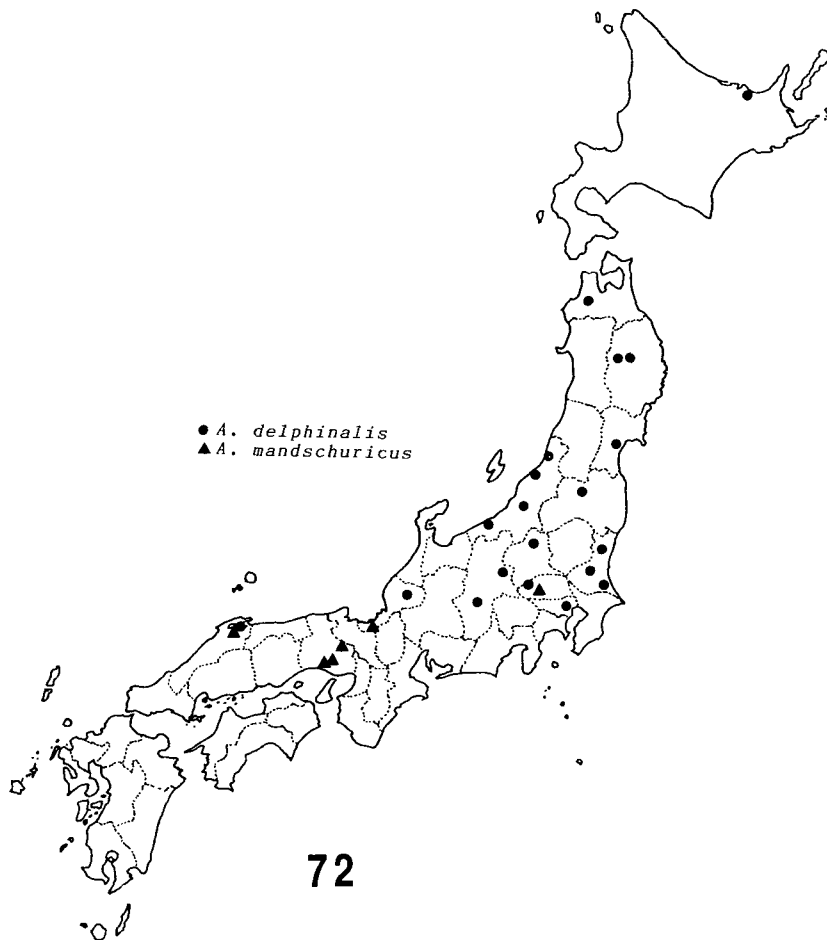

Fig. 72. Distribution of *Allodynerus* species in Japan.

depression distinct.

Black, marked with yellow as follows: two to four spots on clypeus, a very small frontal spot, a short line along inner margin of eye below, a stripe on mandibular base, a short basal line on antennal scape below, a small spot behind each eye, a pair of small triangular markings anteriorly on pronotum, tegula except for margins and basal brown part, a transverse marking on metanotum (sometimes lost), apical part of propodeum in both sides, a medially narrowed apical band on gastral tergite 1, a regular apical band on tergite 2, a laterally dilated apical band on gastral sternite 2. Antennal flagellum below slightly tinged with red. Legs largely blackish; anterior face of fore tibia orange yellow; tarsi of all legs brownish.

Male. Body length (h+th+t1+2): ca. 7.5 mm. Fore wing length: ca. 6.5 mm. Clypeus more deeply emarginate than in the female; but the emargination shallower than in the male of *A. delphinalis*; punctuation on clypeus much stronger than in *delphinalis*. Antennal hook shorter than in *A. delphinalis*; its apex hardly reaching the apex of segment 10 which is only weakly concave at apex (Fig. 65).

Black, with the following parts yellow: clypeus nearly wholly, labrum, mandible except for periphery, stripe on antennal scape below, stripe on temple, short band on pronotum anteriorly (medially interrupted), a pair of small markings on scutellum, a very small marking on propodeum posteriorly, narrow bands on tergites 1 and 2, and sternite 2, a small spot on anterior face of mid coxa, markings on anterior faces of fore and mid tibiae. Antennal flagellum wholly blackish. Tarsi of all legs blackish brown.

Material examined. Honshû: *Fukui-ken* - 2♀♀, Mt. Tokin, 23-24 vii 1974 (TM); *Saitama-ken* - 1♀, Ogano, 7 vi 1970 (TN); *Hyôgo-ken* - 1♀, Sasayama, Tamba, 25 v 1952 (K. Nohara), 1♀, same loc., 1 x 1961 (K. Okamoto), 1♀, same loc., 18 vi 1962 (K. Okamoto), 1♀, same loc., 29 ix 1965 (K. Okamoto), 1♀, Miki, 9 viii 1967 (K. Iwata), 1♂1♀, Takasago, 1987 reared from a nest (Y. Nakatani); *Shimane-ken* - 1♀, Kawatsu, Matsue, 17 viii 1985 (N. Sugiura).

Distribution. Central and western Honshû. Korea (Giordani Soika, 1970); Manchuria.

Taxonomic notes. This rare species is in structure very similar to the preceding species. The presence of relatively long hairs on antennal scape (in at least basal part) may be the most reliable characteristic (in *delphinalis* microscopically pubescent). In coloration, however, this species is very distinctive by its predominantly melanic body. Yellow markings are much reduced: scutellum and mesopleuron never marked with yellow in the female; gastral tergites 3-6 wholly black; legs largely blackish.

Biology. This species nests in bamboo tubes small in inner diameter (Nakatani, 1988). One female specimen from Sasayama, Hyôgo-ken, was placed under the identification label "*Stenodynerus frauenfeldi*", and the female from Miki, Hyôgo-ken, under "*Ancistrocerus japonicus*", both in the collection of the Entomological Laboratory, Kobe University. These arrangements may have been made by Dr. K. Iwata, but it seems that his published observations on the biology of *S. frauenfeldi* and *A. japonicus* do not include *Allodynerus mandschuricus*.

Genus *Euodynerus* Dalla Torre

Euodynerus Dalla Torre, 1904, Gen. Ins. 19: 38 (name for *Odynerus*, subgenus *Leionotus*, III^e Division, Sect. II, Saussure, 1853, Et. Fam. Vesp. 1: 177)(type species: *Vespa dantici* Rossi, 1790); Vecht & Fischer, 1972, Hym. Cat. (n. ed.) 8: 87 (as genus); Giordani Soika, 1978, Soc. Venez. Sc. Nat.-Lavori-, 3: 40 (as genus, in key).

Japanese name: Mikado-dorobachi Zoku.

Medium-sized wasps. Clypeus is variable in shape, apically truncated or shallowly emarginate (Figs. 85-88). Anterior vertical face of pronotum has no transverse striae but punctures laterally. Transverse pronotal carina is complete. Posterior pronotal lobe and pretegular carina are well developed. Tegula is posteriorly produced as a triangular process; posterior end of parategula does not extend beyond the posterior end of tegula. Mesoscutum and scutellum are extensively punctate, without prescutal furrows. Metanotum is not bidentate. Propodeum often bears upper spines just behind metanotum (Fig. 78). Gastral segment 1 is, seen from above, wider than long, usually more than 4/5 as wide as segment 2. Tergite 1 is lacking in both longitudinal groove and transverse carina, posteriorly not swollen, and with an apical semitransparent (lamellate) area. According to Blüthgen (1938b), the Palearctic species of this genus have the gastral tergite 2 not provided with such an apical semitransparent part, but *Euod. nipanicus* is exceptional in this respect (Figs. 98-100).

This genus comprises ca. 60 species in five subgenera in the Palearctic region (Vecht & Fischer, 1972). In Japan four species have been recorded (Yamane & Tano, 1987). Giordani Soika (1986) added one species, *Euod. bicingulatus*, from Hokkaidô and Tôkyô (?), but his description best agrees with smaller specimens of male *Anterhynchium flavomarginatum micado* as will be discussed below.

Key to the Japanese species of the genus *Euodynerus*

1. Vertex with distinct tubercles in ocellar region (one situated just behind anterior ocellus and apically bifid; the others inside posterior ocelli). Posterolateral angles of propodeum inconspicuous, not forming spines. *Euod. trilobus* (Fab.)
- Vertex without tubercles in ocellar region. Posterolateral angles of propodeum projecting as upper spines behind metanotum. 2
2. Clypeus higher than wide, with many vertical carinae and a few punctures, apically truncate (♀). Posterior vertical face of metanotum shining below, coarsely denticulate in uppermost part. Propodeum as seen from above only slightly narrowed toward posterior margin. Metanotum wholly black. *Euod. dantici* (Rossi)
- Clypeus as wide as or slightly wider than long, with relatively dense punctures over the whole disc, without vertical carinae, distinctly emarginate at apex (♀). Posterior vertical face of metanotum not very shining below, finely denticulate in uppermost part. Propodeum as seen from above distinctly narrowed toward posterior margin. Metanotum marked with yellow. 3
3. Gastral sternite 2 basally with a longitudinal groove. Gastral tergite 2 usually with an apical semitransparent part which is more conspicuous in ♂. In profile head and mesoscutum bearing short, erect and uniform hairs as in a brush; hairs on head longer than those on thorax. Clypeus as long as or slightly higher than wide (♀ ♂). Gaster without long hairs. *Euod. nipanicus* (Schult.)
- Gastral sternite 2 basally without distinct groove. Gastral tergite 2 without apical lamella. In profile head and mesoscutum bearing longer, disheveled hairs that are uniform in length. Clypeus wider than high (♀ ♂). Gaster partly with long hairs. *Euod. quadrifasciatus* (Fab.)

Euodynerus (Euodynerus) dantici (Rossi)
(Figs. 76, 79, 80, 88, 90, 101, 102, 108, 110B)

Vespa dantici Rossi, 1790, Fauna Etrusca, 2: 89, pl. 16, fig. 6 (♀)(type loc.: Italia).

Euodynerus dantici: Vecht and Fischer, 1972, Hym. Cat. (n. ed.), 8: 88-89.

Japanese name: Kabaobi-dorobachi.

Diagnosis. Body length (h+th+t1+2): 10.5-11.5 mm in ♀, and 7.5-10.0 mm in ♂. Fore wing length: 9.5-12.0 mm in ♀, and 8.5-10.0 mm in ♂. Structure as in the key.

This species was originally described from Italy, and is widely distributed from Europe to eastern Asia. Anywhere in Japan it is less common than *Euod. nipanicus*, and inhabits a smaller number of islands than does the latter. The northern part of the Ryukyus (Osumi Is.; Mi-shima Is.; Tokara Is.) and possibly Sado-ga-shima, Tsushima Is., Shikoku and Amami-ōshima lack the former (Figs. 108, 110B). In the Central and Southern Ryukyus, this species is more common than in Japan proper, and small islands such as Uke-shima (Amami Is.) and Hateruma-jima (Yaeyama Is.) are often inhabited by it (Fig. 110B). In this region the species is variable in color pattern, but the variation is transitional from islet to islet so that the species cannot be divided into distinct geographical races

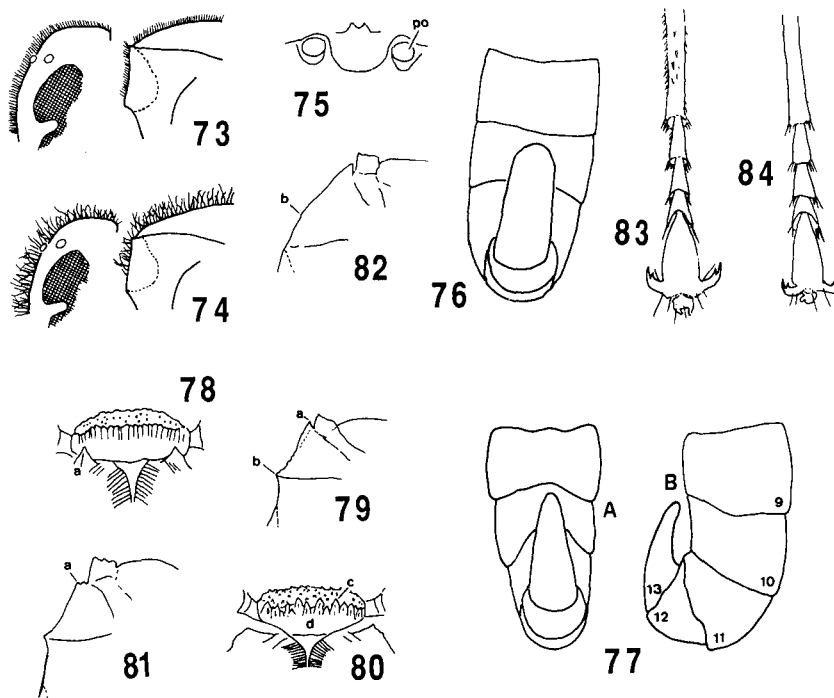

Figs. 73-84. Morphological characters in the Japanese *Euodynerus*. 73, 74, Pubescence of head and thorax in *nipanicus* (73) and *quadrifasciatus* (74); 75, ocellar region in *trilobus*; 76, 77, terminal segments of male antenna in *dantici* (76) and *nipanicus* (77A, B); 78-82, metanotum and propodeum (78, 80, posterior view; 79, 81, 82, profile) in *nipanicus* (78, 79), *dantici* (80, 81) and *trilobus* (82) (after Yamane, 1979); 83, 84, mid tarsus (♂) of *notatus* (European species) (83) and *nipanicus* (84) (after Giordani Soika, 1986).

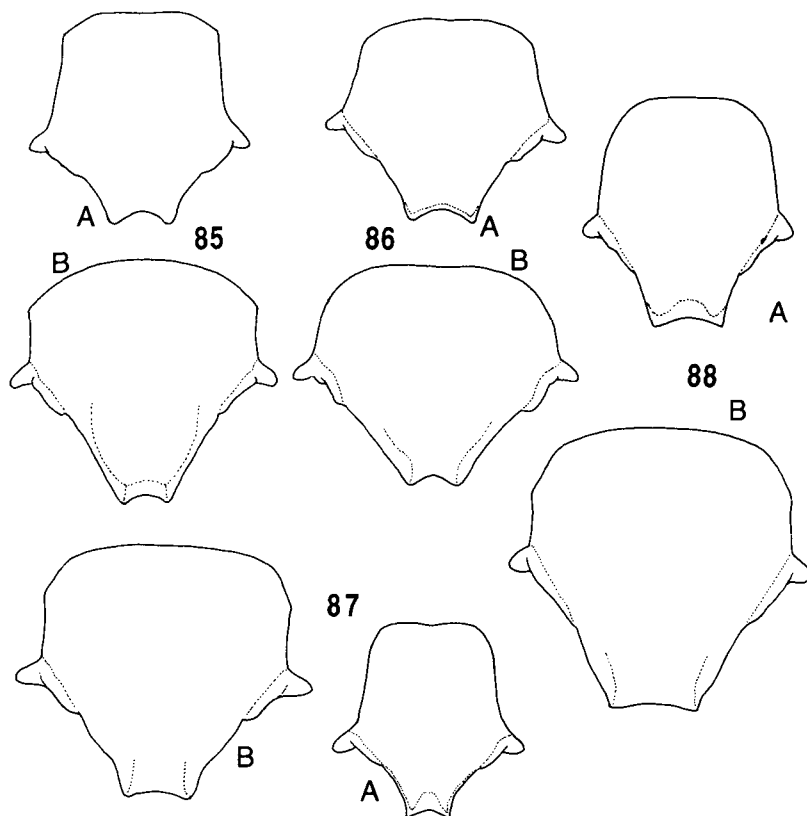

Figs. 85-88. Clypeus of the four Japanese species of *Euodynerus*. 85, *nipanicus*; 86, *quadrifasciatus*; 87, *trilobus*; 88, *dantici*. A, ♂; B, ♀.

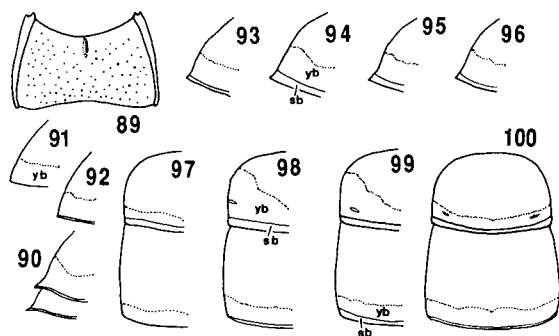

Figs. 89-100. Gastral characters in the Japanese *Euodynerus* (after Yamane, 1979). 89, gastral sternite 2 of *nipanicus*, showing the basal furrow; 90-96, apical part of gastral tergite 2 (profile) in *dantici* (90), *quadrifasciatus* (91), *nipanicus flavicornis* (92, 93), *n. nipanicus* from Honshu - Kyūshū (94, 95), *n. nipanicus* from Hokkaidō (96); 97-100, first two tergites (from above) in *quadrifasciatus* (97), *nipanicus flavicornis* (98), *n. nipanicus* from Honshū - Kyūshū (99), *n. nipanicus* from Hokkaidō (100).

(Yamane & Tano, 1987). I have recognized two principal subspecies in Japan, i.e., *Euod. d. violaceipennis* (Japan proper) and *Euod. d. nigrescens* (C. and S. Ryukyus) (Figs. 101, 102). The subspecies of eastern Asia were discussed at length by Giordani Soika (1986). This species is widely distributed in the Palearctic region, and comprises more than ten subspecies.

Key to the subspecies of *Euod. dantici* occurring in eastern Asia

1. Mesopleuron usually without yellow spot. Northern part of the Far East. subsp. *violaceipennis* (G.S.)
- Mesopleuron always with a yellow spot under wing base. 2
2. Gastral tergites 1-3 in ♀ (also 4 in ♂) each with a yellow or orange yellow apical band. Transbaikal. subsp. *brachytomus* (Kost.).
- Gastral tergites 1-4 in ♀ (also 5 in ♂) each with a yellow apical band. C. and S. Ryukyus, Taiwan. subsp. *nigrescens* (Gusnl.).

Euodynerus dantici violaceipennis Giordani Soika
(Figs. 101, 108)

Euodynerus dantici violaceipennis Giordani Soika, 1973, Boll. Mus. Civ. Stor. Nat. Venez. 24: 114 (♀ ♂) (type loc.: "Canton", China).

Odynerus dantici: Yasumatsu, 1950, Icon. Ins. Jpn. 2nd ed. p. 1455, fig. 4199; Ishikawa, 1965, Icon. Ins. Jpn. Col. Nat. Ed. 3: 297, pl. 149, fig. 4.

Euodynerus dantici brachytomus: Vecht and Fischer, 1972, Hym. Cat. (n. ed.) 8: 88; Yamane, 1979, New Entomol. 28: 8-9, figs. 3, 6, 9, 11; Yamane and Tano, 1987, Trans. Shikoku Entomol. Soc. 18: 333-334.

Japanese name: Kabaobi-dorobachi.

Diagnosis. Female. Black, marked with yellow or orange yellow as follows: clypeus above (the mark with a triangular incision apically in the middle), a frontal spot extending to the upper margin of clypeus, a narrow line in ocular sinus below, a stripe behind each eye, a small basal spot on mandible, antennal scape below, a medially narrowed anterior band on pronotum, tegula with margins and center brown, parategula, a pair of spots on scutellum (often lost), a very small spot under wing base (usually lost), a small spot on posterolateral face of propodeum (sometimes lost), dorsal and lateral parts of gastral tergite 1 except for median basal black area, a medially dilated apical band on tergite 2 (this tergite sometimes with lateral yellow markings which are often fused with the wide apical band), a narrow apical band on tergite 3 (sometimes also on 4), posterolateral corners of sternite 2, all legs except for coxae and the major part of femora. Mandible ferruginous.

Male. Body marking paler than in the female, especially on head and thorax. Markings on sinus of eye and mandible slightly larger than in the female. Tergite 4 always with an apical band. Posterolateral corners of sternite 3 also marked with yellow. Legs extensively yellow.

Material examined. Honshû: *Iwate-ken* - 1 ♀, Ôshuku, Shizukuishi, 7 viii 1987 (SKY); *Miyagi-ken* - 1 ♀, Okunikkawa, 19 viii 1974 (K. Goukon), 2 ♂ ♂, Rifu, 6-13 vii 1980 (K. Goukon); *Nagano-ken* - 1 ♀, Ina, 14 ix 1961 (YM); *Kyôto-fu* - 1 ♀, Kurama, 6 viii 1980 (K. Goukon); *Hyôgo-ken* - 1 ♂ 1 ♀, Sasayama, Tamba, 31 vii 1965

(K. Iwata); Ōsaka-fu— 1 ♀, Ikeda, 4 vii 1947 (K. Iwata); Shimane-ken - 1 ♀, Kawatsu, Matsue, 12 vii 1986 (N. Sugiura); 1 ♂, Matsue, 19 vii 1988 (SKY).

Kyūshū: Fukuoka-ken - 1 ♂, Karumachi, 5 vii 1958 (YM); Kagoshima-ken - 1 ♀, Kushikino, 14 viii 1978 (H. Nagase); 2 ♂ 1 ♀, Taguchi, Kirishima, 3 vii 1981 (SKY), 1 ♀, Kagoshima-shi, 7 viii 1981 (SKY).

Distribution. Honshū; Awaji-shima; Kyūshū. Korea; China.

Biology. Iwata (1938b) observed the nesting biology of this form in Honshū. The female wasp nests in reed tubes used for mats and blinds, and prefers slender tubes (6-7 mm in inner diam.). The number of cells constructed per tube nest ranged from 1 to 9 (n=15, m=4). In every nest an empty cell was seen at the entrance. Nineteen to 50 caterpillars (Tortricidae ?) were stored in larval cells. Judging from the collection data this form may be univoltine.

Euodynerus dantici nigrescens Gusenleitner
(Figs. 102, 110B)

Euodynerus dantici nigrescens Gusenleitner, 1979, Nachrichtbl. Bayer. Entomol. 28: 62 (♀ ♂)(type loc.: Shihmen, N. Taiwan); Tano et al. 1985, Hym. Comm. 23: 31; Giordani Soika, 1986, Boll. Mus. Civ. Stor. Nat. Venez. 35: 133-134.

Euodynerus dantici violaceipennis: Yamane and Tano, 1987, Trans. Shikoku Entomol. Soc. 18: 334-335.

Japanese name: Minami-kabaobi-dorobachi.

Diagnosis. Female. Black, more richly marked with yellow or orange yellow than in the preceding subspecies as follows: clypeus wholly (rarely with a black apical mark), basal marking on mandible, frontal marking extending to the upper margin of clypeus,

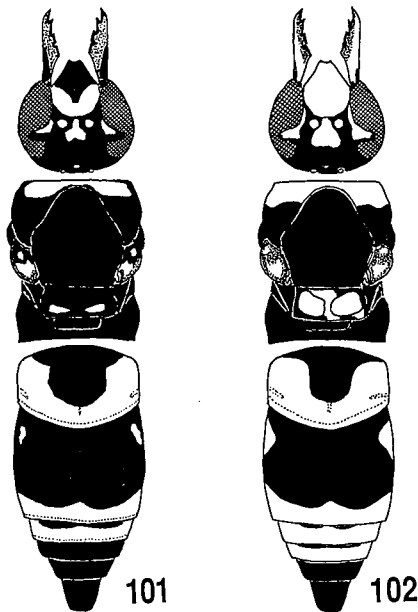

Figs. 101, 102. Body color pattern of *Euodynerus dantici violaceipennis* (101) and *Euod. d. nigrescens* (102).

ocular sinus largely, antennal scape below, relatively long stripe behind each eye, wide pronotal band medially narrowed, spot under wing base (always present), tegula except for margins and center, parategula, a pair of large spots on scutellum (never lost), dorsolateral face of propodeum almost wholly. Gastral color pattern as in the subspecies *violaceipennis*, but lateral projections of yellow apical band on tergite 2 always present, tergite 4 almost always with a yellow apical band, and sternite 3 marked with yellow posterolaterally. Coloration of legs as in the subspecies *violaceipennis*, but hind coxa sometimes yellow anteriorly. Mandible sometimes extensively yellowish.

Male. Very similar in coloration to the female, but body markings much paler and sometimes sulphur yellow. Mandible and legs more extensively, and clypeus always wholly yellow. Tergite 5 with apical band, and sternite 4 marked with yellow posterolaterally.

I have examined a paratype female of this form from Taiwan (sent by Dr. J. Gusenleitner) and many males and females from Taiwan in my collection. No important difference has been found between the populations of the Ryukyus and Taiwan.

Material examined. C. Ryukyus: *Uke-shima* - 4 ♂♂, 12 viii 1987 (M. Tatsuno); *Tokuno-shima* - 1 ♀, Katoku, 7 ix 1983 (T. Moriyama), 1 ♀, Kametoku, 13 vii 1984 (SKY); *Okinoerabu-jima* - 2 ♂♂, Tokutoki, 4 viii 1972 (TN), 1 ♀, China, 19 v 1981 (Kukidome & Koya); 1 ♀, Shinjō - Tamina, 14 vii 1981 (Y. Takai), 1 ♂2 ♀♀, Wadomari, 15 vii 1984 (SKY); *Yoron-tō* - 1 ♂, 4 vi 1985 (SKY), 2 ♂♂, Chabana, 6 viii 1972 (TN); *Okinawa-jima* - 1 ♀, Naha, 9 viii 1972 (TN), 1 ♀, Tanodake, 26 viii 1979 (H. Nagase), 1 ♀, Hentona, 4 vii 1981 (AN), 1 ♂, same loc., 3 vi 1983 (AN), 1 ♂, same loc., 27 vii 1987 (SKY); *Izena-jima* - 1 ♂, Nakada, 25 vii 1967 (T. Kifune); *Kouri-jima* - 1 ♀, 18 x 1988 (Y. Kusui); *Miyagi-jima* - 1 ♂, 31 vii 1971 (T. Kifune).

S. Ryukyus: *Miyako-jima* - 3 ♂♂, Sunayama, 2-4 viii 1984 (CN); *Ishigaki-jima* - 1 ♂, Kabira, 4 vi 1983 (YH), 1 ♂, Kabira, 29 vii 1984 (CN), 1 ♂, Shinkawa, 19 vi 1986 (SI), 1 ♂, Kabira, 21 vi 1986 (SI), 7 ♂♂, Omotodake, 8 vii 1988 (K. Nakamine); *Taketomi-jima* - 2 ♂♂1 ♀, 8 vii 1988 (K. Nakamine); *Hateruma-jima* - 14 ♂♂, 30 vi - 1 vii 1988 (SKY).

Distribution. Amami Is. (*Uke-shima*; *Tokuno-shima*; *Okinoerabu-jima*; *Yoron-tō*); Okinawa Is. (*Izena-jima*; *Okinawa-jima*; *Kouri-jima*; *Yagaji-jima*; *Miyagi-jima*; *Kume-jima*); Miyako Is. (*Miyako-jima*); Yaeyama Is. (*Ishigaki-jima*; *Taketomi-jima*; *Hateruma-jima*). Taiwan.

Euodynerus (Pareuodynerus) nipanicus (Schulthess)
(Figs. 73, 77, 78, 80, 84, 85, 89, 92-100, 103-106, 107, 110A)

Lionotus tomentosus var. *nipanicus* Schulthess, 1908, Mitt. Schweiz. Entomol. Ges. 11: 287-288 (♂)(type loc.: Japan).

Euodynerus (Pareuodynerus) notatus: Yamane and Tano, 1987, Trans. Shikoku Entomol. Soc. 18: 335-336.

Euodynerus (Pareuodynerus) notatus notatus: Vecht and Fischer, 1972, Hym. Cat. (n. ed.), 8: 95-96 (from Japan).

Euodynerus (Pareuodynerus) nipanicus: Giordani Soika, 1986, Boll. Mus. Civ. Stor. Nat. Venez. 35: 135-138.

Japanese name: Mikado-dorobachi.

Diagnosis. Body length (h+th+t1+2): 7.5-11.0 mm in ♀, 6.5-10.5 mm in ♂. Fore wing length: 9.5-10.5 mm in ♀, 7.5-9.0 mm in ♂. Structure as in the key.

This species (*nipanicus*) has been treated by Japanese authors (e.g., Matsumura, 1911; Yasumatsu, 1952) as *Odynerus micado* Kirsch or *O. quadrifasciatus* (Fabricius)(both agreeing in the Japanese name applied, Mikado-dorobachi). But, as pointed out by Yamane (1979) the form here is no doubt a close relative of *Euod. notatus*, and Yamane and Tano (1987) considered it to be a Japanese subspecies of the latter, which is Palearctic in distribution.

On the other hand, Giordani Soika (1986) separated it specifically from *notatus*, and applied the name *nipanicus* to it. He enumerated the following differences: (1) in *nipanicus* the punctation, especially on gaster, stronger and denser, (2) gastral tergite 2 more or less strongly reflexed at apex to form a lamella, which is more developed in the male than in the female, (3) sternite 2 basally more convexed (these three are useful to distinguish this species from *notatus* and *quadrifasciatus*), (4) terminal segment of mid tarsus of the male much more slender than in *notatus* (Figs. 83, 84), (5) in both sexes, temple less developed and seen from above shorter than the eye width, (6) digitus of male genitalia narrower, elongate, more widely round at apex than in *notatus*. Giordani Soika's view that the form is a distinct species is here adopted.

The species may widely occur in eastern Asia except in the tropics. At least some of the previous records of *Euod. notatus* from the Far East may be referable to *nipanicus* (Giordani Soika, 1986).

My comparison of *nipanicus* from the Japanese mainlands with "*Odynerus flavolineatus*" from the Ryukyus (Matsumura, 1911) has revealed that these are geographical races of the same species. I recognize three subspecies in Japan, one from the mainlands and the other two from the Ryukyus. The Hokkaidô population of *nipanicus nipanicus*, referred to as *Euod. notatus pubescens* by Yamane and Tano (1987), slightly differs in structure and color pattern from the form inhabiting Honshû, Shikoku and Kyûshû. However, in this paper both the forms are tentatively treated under the same subspecies, because the subspecies name to be applied to the Hokkaidô form may be fixed only after comparing the Japanese forms with those from Sakhalin and eastern Siberia.

Key to the Japanese subspecies of *Euodynerus nipanicus*

1. Clypeus usually wholly black, rarely yellow at base (♀). Scutellum often lacking yellow markings (♀ ♂). Dorsolateral face of propodeum and gastral sternite 2 rarely with large spots (♀ ♂). Legs largely black or brownish subsp. *nipanicus* (Schult.)
 - Clypeus largely yellow, often laterally or apically with black markings (♀). Scutellum always with yellow markings (♀ ♂). Dorsolateral face of propodeum always and gastral sternite 2 sometimes with large yellow spots (♀ ♂). Legs extensively marked with yellow (♀). 2
2. Upper tooth of superior ridge of propodeum always yellow; this yellow part is united with a large yellow marking, which spreads over the dorsolateral face of propodeum (♀ ♂). Clypeus often with lateral black or brownish markings (♀). .. subsp. *flavicornis* Yam.
 - Upper tooth of superior ridge of propodeum usually black; when yellow it is separated from the yellow marking of propodeum (♀ ♂). Clypeus sometimes with black or brownish markings apically and less often laterally (♀). subsp. *ryukyuensis* Tano

Euodynerus nipanicus nipanicus (Schulthess) (Figs. 94-96, 99, 103, 104, 107, 110A)

Odynerus micado Kirsch: Matsumura, 1911, Thous. Ins. Jpn. Suppl. 3: 682, pl. 39, fig. 14 (subgenus *Leionotus*); 1930, Ill. Thous. Ins. Jpn. 2: 13-14, pl. 2, fig. 14; Yano, 1932, Icon. Ins. Jpn. 1st ed. p. 308.

Odynerus micado Kriechb.: Matsumura, 1931. 6000 Ill. Ins. Jpn.-Emp. p. 16, no. 78.

Odynerus (Lionotus) flaviclypeatus Sonan, 1930, Trans. Nat. Hist. Soc. Formosa, 20: 355 (♂)(type loc.: Kagoshima, Kyūshū).

Rhynchium satsumanus (!) Sonan, 1930, Trans. Nat. Hist. Soc. Formosa, 20: 356 (♀)(type loc.: Kagoshima, Kyūshū).

Odynerus nigripes: Yasumatsu, 1935, Kontyū, 9: 223-225.

Odynerus quadrifasciatus: Yasumatsu, 1950, Icon. Ins. Jpn. 2nd ed. p. 1456, fig. 4202; Ishikawa, 1965, Icon. Ins. Jpn. Col. Nat. Ed. 3: 297, pl. 149, fig. 3.

Euodynerus notatus ssp. 2, 3: Yamane, 1979, New Entomol. 28: 10-11, figs. 18-20, 23, 24 (in key).

Euodynerus notatus nipanicus: Yamane and Tano, 1987, Trans. Shikoku Entomol. Soc. 18: 337-338, fig. 7.

Euodynerus notatus pubescens: Yamane and Tano, 1987, Trans. Shikoku Entomol. Soc. 18: 337, fig. 6.

Japanese name: Mikado-dorobachi.

Diagnosis. Female. Black, with the following parts yellow: a basal marking on clypeus (usually absent), an interantennal spot, basal triangular marking on mandible, small spot on temple, a medially narrowed band on the horizontal part of pronotum anteriorly, tegula and parategula largely, a spot on dorsal mesepisternum, irregular marking(s) on scutellum (often lost), metanotum largely, irregular marking(s) on dorsolateral face of propodeum (often lost), propodeal valve, apical bands on gastral tergites 1-3 (sometimes also 4), a medially widely interrupted apical band on sternite 2. Legs blackish brown; mid and hind tibiae often irregularly marked with yellow.

Male. More extensively marked with yellow. Clypeus almost wholly, antennal scape below, anterior face of mid and hind coxae, apical 1/3 - 2/3 of all femora below, outer faces of all tibiae yellow. Gastral tergites 1-5 usually with apical bands; sternite 2 with a pair of irregular yellow markings and a complete apical band; posterolateral corners of sternite 3 often with yellow spots. All the tarsi more or less yellowish.

In the specimens from Hokkaidō, apical lamella of tergite 2 less developed (Fig. 100); in the male the lamella not strongly reflexed (Fig. 96). Yellow markings less extensive: clypeus, mesepisternum, scutellum and propodeum almost always without yellow markings (Fig. 103), and apical band on sternite 2 of the male often medially interrupted.

The description of the "female" of *Odynerus micado* by Matsumura (1911, 1931) well

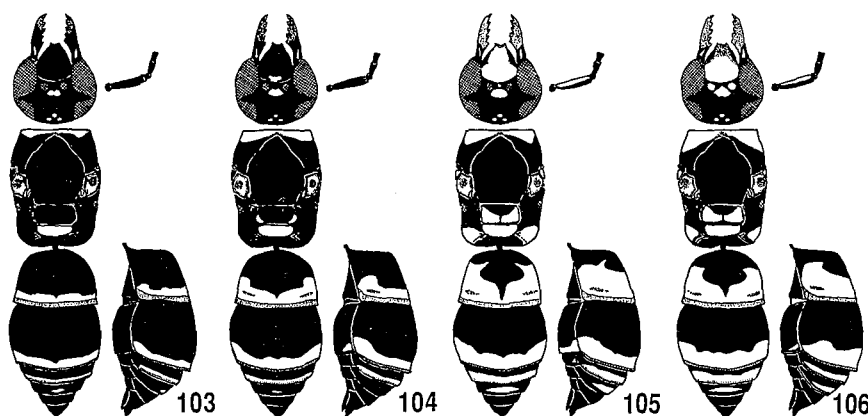

Figs. 103-106. Body color pattern of *Euodynerus nipanicus* (after Yamane & Tano, 1987). 103, ssp. *nipanicus* from Hokkaidō; 104, ssp. *nipanicus* from Honshū - Kyūshū; 105, ssp. *flavicornis*; 106, ssp. *ryukyuensis*.

agrees with the male sex.

Material examined. Hokkaidô: 1 ♂, Sapporo, 25 viii 1935 (Y. Sugihara), 2 ♂♂, same loc., 4-10 vii 1954 (K. Kamijo), 1 ♀, same loc., 14 vii 1955 (K. Kamijo), 1 ♀, Miyanomori, Sapporo, 5 vii 1961 (SKY), 1 ♀, Obihiro, 3 viii 1975 (M. Usui), 1 ♀, Sapporo, 9 viii 1976 (T. Sunose).

Honshû: *Iwate-ken* - 1 ♀, Kuriyagawa, Morioka, 16 vi 1964 (YM), 1 ♀, same loc., 25 viii 1968 (YM), 2 ♂♂ 1 ♀, Jôhôji, 21 viii 1962 (HI); *Fukushima-ken* - 1 ♀, Yunohana, 27 vii 1980 (HI); *Niigata-ken* - 1 ♂ 2 ♀♀, Nagaoka, 22-23 viii 1951 (Yamazaki), 1 ♂ 1 ♀, same loc., 29 viii 1952 (Yamazaki), 1 ♂, Fukushima-gata, 10 ix 1977 (HI), 1 ♀, same loc., 9 ix 1979 (HI), 1 ♂, Shidaijima, 20 viii 1977 (HI), 1 ♀, same loc., 11 ix 1981 (HI), 2 ♂♂, Shibata, 21 ix 1978 (HI), 1 ♂, Kami-ishikawa, Shibata, 12 viii 1979 (HI), 1 ♂, Senami, 31 v 1983 (KB), 1 ♂, same loc., 13 vi 1984 (KB), 1 ♀, same loc. 25, ix 1984 (KB); *Nagano-ken* - 1 ♂ 1 ♀, Habiro, Ina, 1 ix 1961 (YM), 1 ♂, Minamiminowa, Ina, 25 v 1962 (YM), 4 ♂♂, same loc., 8-17 vi 1962 (YM), 1 ♂, Niiyama, Ina, 24 vii 1962 (YM), 2 ♂♂, Habiro, Ina, 27-31 vii 1962 (YM), 2 ♂♂ 1 ♀, same loc., 4-10 viii 1962 (YM), 4 ♂♂, same loc., 17-31 viii 1962 (YM), 2 ♂♂ 1 ♀, 1-12 ix 1962 (YM); *Ishikawa-ken* - 1 ♂, Nakashima, 26 vii 1948 (I. Togashi); *Aichi-ken* - 1 ♀, Irako, Atsumi Pen. 6 viii 1977 (Y. Takai); *Kyôto-fu* - 1 ♂, Saga, 27 v 1955 (K. Iwata), 1 ♀, Goshô, 18 vii 1955 (K. Iwata); *Wakayama-ken* - 4 ♂♂, Kiitanabe, 4 viii 1965 (K. Iwata); *Hyôgo-ken* - 2 ♀♀, Sasayama, Tamba, 17 x 1952 (K. Iwata); *Shimane-ken* - 1 ♂, Mt. Makuragi, 31 v 1983 (YM), 1 ♂, Nishikawatsu, Matsue, 22 vii 1985 (M. Goubara).

Oki Is. (Shimane-ken): *Nishino-shima* - 1 ♀, Urago, 11 v 1982 (YM).

Shikoku: *Kôchi-ken* - 1 ♂, Monobe, Nankoku, 2 v 1974 (SI), 1 ♀, same loc., 23 vi 1975 (SI); *Kagawa-ken* - 1 ♂ 1 ♀, Oiwaigaike, 26 vii 1964 (K. Iwata).

Kyûshû: *Fukuoka-ken* - 1 ♂, Harumachi, Fukuoka-shi, 5 vii 1958 (YM), 1 ♂, Hakozaiki, Fukuoka-shi, 14 ix 1958 (YM), 2 ♂♂ 1 ♀, same loc., 5-23 vii 1959 (YM), 1 ♂ 1 ♀, Wajiro, Kasuya, 15 ix 1959 (YM); *Nagasaki-ken* - 1 ♂, Haraguchi, Ômura, 16 viii 1967 (R. Ohgushi), 1 ♀, same loc., 27 viii 1967 (R. Ohgushi); *Kagoshima-ken* - 10 ♂♂, Kôrimoto, Kagoshima-shi, 6-7 viii 1981 (SKY), 1 ♂, same loc., 26 viii 1981 (SKY), 1 ♂, Meiwa, Kagoshima-shi, 15 viii 1981 (SKY), 2 ♂♂, Shiroyama, Kagoshima-shi, 30 vii 1981 (SKY), 1 ♂, Ichiki, 8 v 1984 (AN), 3 ♂♂, Kanoya, 30 viii - 8 ix 1981 (SI), 1 ♂, Sata, 10 vi 1979 (H. Nagase), 1 ♂, Ônakano, Sata, 10 x 1978 (H. Nagase), 1 ♀, Makurazaki, 8 ix 1984 (AN).

Tsushima Is. (Nagasaki-ken): *Kami-agata* - 1 ♂, Nii, Toyotama-son, 19 viii 1968 (I. Hiura).

Island close to Kagoshima-ken-hondo: *Akune-ôshima* - 1 ♂, 5 viii 1983 (SKY).

N. Ryukyus: *Tane-ga-shima* - 1 ♂, Hamada, 11 vii 1983 (SKY), 3 ♂♂, Kaminaka, 12 vii 1983 (SKY), 1 ♀, Hamada, 2 viii 1984 (SKY), 1 ♂, Ikeno, 21 vii 1984 (S. Watahiki), 1 ♀, Kamome, 5 viii 1986 (M. Tatsuno); *Mage-shima* - 4 ♂♂, 22 vii 1984 (S. Watahiki); *Yaku-shima* - 1 ♂, Miyanoura, 10 v 1981 (SKY), 11 ♂♂ 2 ♀♀, same loc., 8-10 viii 1981 (SKY), 1 ♀, Onoaida, 9 viii 1981 (SKY), 1 ♂, Ambô, 11 v 1981 (SKY), 2 ♂♂, Shitogo, 10 viii 1981 (SKY), 4 ♂♂, Miyanoura, 26-28 v 1982 (SI), 1 ♀, Onoaida, 29 vi 1982 (SI), 1 ♂, same loc., 27 vii 1982 (SI), 2 ♂♂, Issô, 30 vii 1988 (SKY); *Kuchinoerabu-jima* - 1 ♂, 16-17 v 1982 (SKY), 1 ♀, Hommura, 18 v 1989 (H. Watanabe).

Distribution. Hokkaidô; Honshû; Iwai-jima; Oki Is. (Nishino-shima); Shikoku; Kyûshû; Tsushima Is. (Kami-agata; Shimo-agata); Amakusa Is. (Shimo-jima); Akune-ôshima; Ôsumi Is. (Tane-ga-shima; Mage-shima; Yaku-shima; Kuchinoerabu-jima); Ogasawara Is. (introduced?).

Biology. Iwata (1938b, 1979) intensively studied the biology of this form (referred to as *Odynerus nigripes*). This wasp is bivoltine and a tube-renter, usually nesting in bamboo or reed tubes placed horizontally above the ground. Nests are also made in tubes lying on the ground, those placed vertically, small holes in the stone, deserted mud cells of *Eumenes fraterculus* on stones and of *Scelifron madraspatanum*, and empty cocoons of *Monema flavescens* (Lepidoptera, Heterogeneidae). The number of brood cells constructed per nest ranged from 1 to 8 (n=50, m=4 [26%]). Empty cells are often constructed between brood cells as well as at the entrance, and are usually smaller than the brood cells in length. The wasp sometimes arranges the brood and empty cells alternately. This behavior is exceptional among the Japanese Eumenidae. The cell partitions are made of mud, and not water-proofed, measuring 1 to 3 mm in thickness. The outermost wall is much thicker (5-

10 mm thick) and water-proofed. The female wasp hunts larvae of Microlepidoptera, especially of Tortricidae. This species is used to control leaf-eating pests (Tortricidae) of apple trees (Takeshima, 1971; Iwata, 1979; see Chapter 1). The female does not guard her nest, and quickly provisions and closes cells one after another.

Parasite: *Pseudoxenos iwatai* (Strepsiptera, Stylopidae). Parasitoids: a phorid, a tachinid (Diptera), *Chrysis ignita*, *C. viridula*(?) (Hymenoptera, Chrysididae), *Macrosiagon nasuta* (Coleoptera, Rhipiphoridae), and *Argyrotaea distigma*.

Euodynerus nipanicus flavicornis Sk. Yamane
(Figs. 92, 93, 98, 105, 110A)

Odynerus flavolineatus Smith: Matsumura, 1911, Thous. Ins. Jpn. Suppl. 3: 111, no. 681, pl. 39, fig. 13; Matsumura and Uchida, Ins. Matsum. 1: 36; Kuroiwa, 1926, Trans. Nat. Hist. Soc. Formosa, 16: 140; Matsumura, 1930, Ill. Thous. Ins. Jpn. 2: 13, pl.2, fig. 13; 1931, 6000 Ill. Ins. Jpn.-Emp. p. 16, no. 77. (Misidentification.)

Euodynerus notatus flavicornis: Yamane & Tano, 1987, Trans. Shikoku Entomol. Soc. 18: 339, fig. 8 (♀ ♂) (type loc.: Okinawa-jima).

Japanese name: Kisuji-dorobachi.

Diagnosis. Very distinctive in coloration from the nominotypical subspecies of Japan proper. Apical lamellate area of gastral tergite 2 in the male very narrow (Figs. 92, 93).

Female. Black, marked with yellow as follows: clypeus largely, frontal marking, a stripe at the base of mandible, antennal scape below, stripe behind each eye, wide pronotal band medially narrowed, pronotal tubercle partly, tegula except for margins and central brown spot, parategula, metanotum including posterior vertical face above, spot under wing base, dorsolateral face of propodeum usually wholly, a very wide band on gastral tergite 1 laterally much dilated, a wide, laterally dilated apical band on tergite 2, narrow apical bands on tergites 3 and 4, posterolateral corners of gastral sternite 2 (sternite 2 often with a yellow, narrow apical band), mid and hind coxae partly, apical 1/3 to 1/2 of all femora, tibiae of all legs. Clypeus often with lateral black areas, and rarely with a black or brown mark apically. Mandible brownish. Superior ridge of propodeum (especially upper tooth) yellow or orange yellow; the upper tooth involved in the large yellow marking on propodeal dorsum. Yellow of femora and tibiae tinged with brown; tarsi dark brown.

Male. Similar to the female, more extensively marked with yellow. Clypeus entirely yellow; frontal yellow mark often with a projection which reaches the upper margin of clypeus; legs largely yellow.

Material examined. C. Ryukyus: *Kikai-jima* - 1 ♀, viii 1959 (E. Nitta), 1 ♂1 ♀, 5 viii 1961 (H. Tanaka), 1 ♂1 ♀, 26-27 viii 1984 (S. Watahiki); *Amami-ôshima* - 1 ♀, 20 viii 1943 (H107), 1 ♂1 ♀, Shimmura, Sumiyô, 11 vii 1981 (YH), 1 ♂, Gusuku, 4 v 1981 (T. Fujisawa), 2 ♂ ♂3 ♀ ♀, Koniya, 22 vi 1987 (SKY), 1 ♂, Sumiyô, 22 vi 1987 (SKY), 1 ♂, Nishinakama, 25 vii 1987 (AN), 1 ♂, Koniya, 14 viii 1987 (M. Tatsuno), 2 ♀ ♀, Koniya, 20 x 1987 (SI); *Kakeroma-jima* - 1 ♂, Osai, 27 ix 1987 (SKY), 4 ♂ ♂1 ♀, Nishiamuro, 28 ix 1987 (SKY); *Uke-shima* - 2 ♂ ♂3 ♀ ♀, 12 viii 1987 (M. Tatsuno); *Okinoerabu-jima* - 1 ♀, 17 vii 1984 (M. Maegata); *Yoron-tô* - 1 ♀, 6 vi 1985 (SKY); *Izena-jima* - 1 ♂, Nakada, 25 vi 1967 (T. Kifune); *Okinawa-jima* - 1 ♂, Hyakuna, 1 vii 1981 (AN), 7 ♂ ♂1 ♀, Hentona, 1-6 vi 1983 (AN), 1 ♀, same loc., 27 vii 1987 (SKY); *Sezoko-jima* - 1 ♂, 28 v - 1 vi 1982 (Y. Ikimori & Y. Ôhira); *Tokashiki-jima* - 1 ♀, 11 x 1988 (SKY); *Miyagi-jima* - 1 ♂, 31 vii 1971 (T. Kifune).

Distribution. Amami Is. (Kikai-jima; Amami-ôshima, Kakeroma-jima; Uke-shima; Tokuno-shima; Okinoerabu-jima; Yoron-tô; Okinawa Is. (Izena-jima; Okinawa-jima;

Sezoko-jima; Yagaji-jima; Miyagi-jima; Tokashiki-jima; Kume-jima).

Biology. No information is available.

Euodynerus nipanicus ryukyuensis Tano

(Figs. 106, 110A)

Odynerus flavolineatus: Matsumura, 1911, Thous. Ins. Jpn. Suppl. 3: 111, no. 681, pl. 39, fig. 13; Matsumura and Uchida, Ins. Matsum. 1: 36; Matsumura, 1931, 6000 Ill. Ins. Jpn.-Emp. p. 16, no. 77.

Euodynerus notatus ryukyuensis: Yamane and Tano, 1987, Trans. Shikoku Entomol. Soc. 18: 339-340, fig. 9 (♀ ♂)(type loc.: Ishigaki-jima, Yaeyama Is.).

Japanese name: Yaeyama-mikado-dorobachi.

Diagnosis. Female. Similar to the subspecies *flavicornis*, but distinguished from the latter by the following points: apical portion of clypeus more often marked with brown (lateral parts also often marked with black as in *flavicornis*), interocular area above with a small yellow spot close to each eye, frontal marking often with a narrow projection which reaches the upper margin of clypeus, yellow marking of dorsolateral face of propodeum less developed and not involving the upper tooth of superior ridge (Fig. 106).

Male. Lacking interocular spots. Distinguished from the preceding subspecies by the less developed yellow marking on the dorsolateral face of propodeum.

Material examined. S. Ryukyus: *Miyako-jima* - 5 ♂ ♂1 ♀, Ueji, 28 ix 1988 (SI); *Tarama-jima* - 1 ♀, 18 vii 1987 (SKY), 3 ♂ ♂1 ♀ ♀, 29 vi 1988 (SKY); *Ishigaki-jima* - 2 ♂ ♂1 ♀, Shinkawa, 19 vi 1986 (SI), 1 ♀, Kabira, 22 vii 1987 (SKY), 1 ♀, Shiraho, 26 vi 1987 (SKY), 5 ♂ ♂1 ♀, Omoto-dake, 8 vii 1988 (K. Nakamine); *Kohama-jima* - 1 ♀, 25 vii 1987 (SKY); *Iriomote-jima* - 2 ♀ ♀, Toyohara, 30 vii 1983 (AN), 1 ♂, Ôtomi, 29 vii 1983 (AN), 1 ♂1 ♀, Ôhara, 30 vii 1983 (AN), 1 ♀, same loc., 25 vii 1983 (A. Matsumoto), 4 ♂ ♂, 17-18 viii 1983 (S.F. Sakagami & YM), 1 ♂, Ôtomi, 25 vii 1985 (AN), 1 ♂, Uehara, 2 vii 1988 (SKY), 1 ♂1 ♀, Ôhara, 20 vi 1988 (K. Nakamine); *Hateruma-jima* - 1 ♂1 ♀, 1 vii 1988 (SKY); *Yonaguni-jima* - 9 ♂ ♂3 ♀ ♀, Sonai, 5 vii 1988 (SKY).

Distribution. Miyako Is. (Miyako-jima); Tarama Is. (Tarama-jima); Yaeyama Is. (Ishigaki-jima; Kohama-jima; Iriomote-jima; Hateruma-jima; Yonaguni-jima).

Biology. On Tarama-jima (June 30 1988) I observed some female wasps nesting in bamboo tubes placed horizontally as supports for melon vines at about 1.5 m above ground.

Euodynerus (Pareuodynerus) quadrifasciatus (Fabricius)

(Figs. 74, 86, 91, 109)

Vespa quadrifasciata Fabricius, 1793, Entomol. Syst. 2: 266 (♂)(type loc.: Denmark).

Odynerus (Lionotus) tomentosus Thomson, 1870, Opusc. Entomol. 2: 86.

?*Odynerus (Lionotus) quadrifasciatus* Herr.-Schaff.: Schulthess, 1934, Arb. Morph. Taxon. Entomol. 1: 75 (in key).

Japanese name: Nise-mikado-dorobachi.

Diagnosis. Body length (h+th+t1+2): 8.5-10.0 mm in ♀, 6.0-7.5 mm in ♂. Fore wing length: 8.5-10.0 mm in ♀, ca. 9 mm in ♂. Structural characters as in the key.

This species has long been confused with *Euod. nipanicus* (= *Euod. notatus* sensu Yamane & Tano, 1987) under the Japanese name "Mikado-dorobachi". Two subspecies are known in Japan, and both are relatively rare.

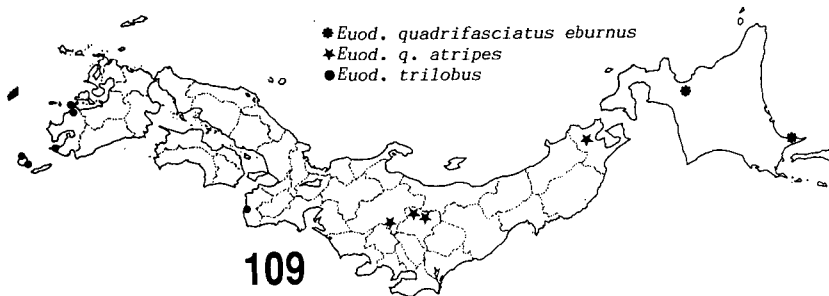
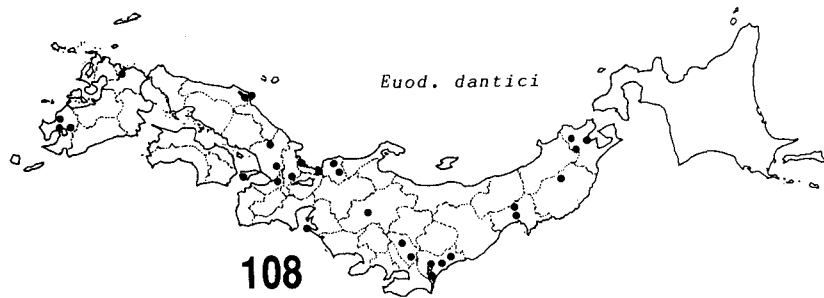
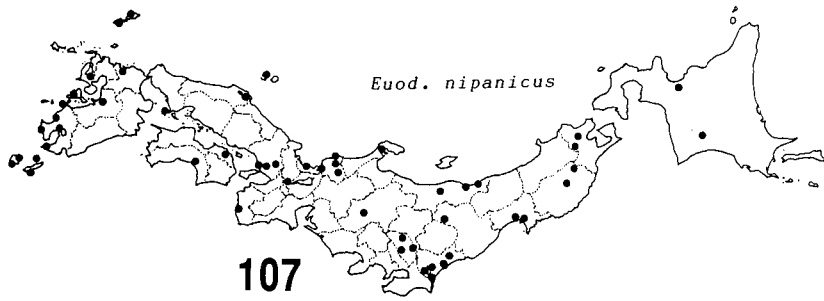

Figs. 107-109. Distribution of the four *Euodynerus* species on the Japanese mainlands.

Information about the nesting biology of this species in Japan is not available. According to Nielsen (1932) and Blüthgen (1961), in northern Europe, the species nests in pre-existing burrows in wood. Brood cells are provisioned with larvae of tortricid moths.

Euodynerus quadrifasciatus eburnus Sk. Yamane
(Fig. 109)

Euodynerus quadrifasciatus subsp.: Yamane, 1979, *New Entomol.* 28: 10 (in key), figs 5, 15, 21.

Euodynerus quadrifasciatus eburnus: Yamane and Tano, 1987, *Trans. Shikoku Entomol. Soc.* 18: 340-341 (♀ ♂)(type loc.: Sapporo, Hokkaidō).

Diagnosis. Female. Black, marked with ivory-white and pale yellow as follows: frontal mark, a small spot on mandibular base, small spot behind each eye, narrow pronotal band interrupted medially, anterior and posterior spots on tegula, dorsal face of metanotum, narrow regular bands on gastral tergites 1-4, posterolateral corners of gastral sternite 2. Antenna and legs almost wholly black; tarsi tinged with reddish brown.

Male. Very similar to the female. In addition to the markings mentioned for the female, the following parts are ivory-white or pale yellow: clypeus wholly, antennal scape below, mandible largely, an apical band on tergite 5, posterolateral corners of sternite 3, anterior faces of mid and hind coxae and mid femur, and outer faces of all tibiae.

This form differs from the nominotypical subspecies by the tegula and metanotum always marked with pale color, and the almost wholly black legs as well as ivory-white body markings.

Material examined. Hokkaidô: 1 ♂, Toyotaki, Sapporo, 2 vii 1972 (SKY), 1 ♀, same loc., 2 vii 1980 (S. Makino) (holotype), 1 ♂, Iwaobetsu, Shiretoko, 10 vii 1975 (T. Matsumura).

Distribution. Hokkaidô.

Euodynerus quadrifasciatus atripes Giordani Soika
(Fig. 109)

Euodynerus quadrifasciatus atripes Giordani Soika, 1976, Ann. Hist.-Nat. Mus. Nat. Hung. 68: 292 (♀) (type loc.: Ryang-gang, N. Korea); Yamane and Tano, 1987, Trans. Shikoku Entomol. Soc. 18: 341 (from Japan proper).

Diagnosis. Female. Much as in the preceding subspecies except that body markings are yellow or orange yellow. Other minor differences are: pronotal band in each side posteriorly dilated (in *eburnus* posterior margin straight); anterior spot on tegula usually much smaller than posterior one, sometimes even lost.

Male. Distinguished from the preceding subspecies by the darker coloration and the following variations: scutellum sometimes with a pair of small yellow spots, sternite 2 rarely with a yellow apical band in addition to lateral markings.

Material examined. Honshû: Aomori-ken - 1 ♂, Hirosaki, 5 vi 1983 (M. Yamada); Gumma-ken - 1 ♂, Onioshidashi, Tsumagoi, 19 vii 1967 (T. & H. Suda); Nagano-ken - 1 ♀, Mt. Yatsugatake, Chino, 3 vii 1963 (YM).

Distribution. Central and northern Honshû. Korea.

Taxonomic notes. This form was originally described by Giordani Soika (1976) based upon a single female from Korea, but his description was so brief that the present treatment of the Japanese population should remain tentative.

Euodynerus (Pareuodynerus) bicingulatus Giordani Soika

Euodynerus (Pareuodynerus) bicingulatus Giordani Soika, 1986, Boll. Mus. Civ. Stor. Nat. Venez. 35: 138-139, fig. 41 (♂)(type loc.: Tokyo (?)).

Diagnosis. Giordani Soika's original description will be reproduced here (translation by me).

[Male. Similar to *E. notatus* (Jur.), from which the present species is distinguished by the following characters: Antenna much longer; segments 5-11 all longer than wide.

Temple less developed, seen from above much shorter than the superior lobe of eye. Pronotal carina not angulate on the dorsolateral parts. Parategula well developed, long, finger-shaped; its apex extending beyond the apex of tegula. Superior carina of propodeum less developed; instead, lateral carina much more developed than in *notatus*, forming a large black lamella which, connected with the inferior carina, forms a robust denticle that is flattened triangle in shape. Tergite 2 not reflexed at apex. Sternite 2 convex at base, slightly convex posteriorly, without median longitudinal furrow at base.

Punctuation on the first two tergites coarse and dense, with interspaces in average smaller than punctures; near the apex of tergite 2 punctures denser but not larger. On tergites 3-4 and 5 punctuation densest, considerably coarser than on tergite 2. Tergite 6 with punctures of the same size but rather sparse. Sternite 2 laterally with large and dense punctures; punctures much smaller and sparser in the middle.

Black, with the tegula and legs reddish brown or blackish brown. Yellow are: clypeus, antennal scape below, a rhombic frontal marking, a narrow line on temple, pronotal band medially narrowed, a marking on mesepisternum, a line on tegula, parategula, small irregular spots on scutellum, a very narrow line on metanotum, apices of femora, markings on fore and mid tibiae, apical band on tergite 1 that is narrow and regular, apical band on tergite 2 that is regular and slightly wider, markings at posterolateral corners of sternite 2. Wings diffusely brownish.

Body length (to the posterior margin of tergite 2): 11 mm.

Female unknown.]

Distribution. Hokkaidô (?); Honshû (Tôkyô)(?).

Taxonomic notes. I have never seen any *Euodynerus* specimen that agrees with Giordani Soika's description of *Euod. bicingulatus*. On the other hand, small male specimens of *Anterhynchium flavomarginatum micado* well agree with his description, with minor disagreements in the condition of punctuation. In this paper I include this "species" in this genus tentatively, but not in the key to the Japanese species.

Euodynerus trilobus (Fabricius)

(Figs. 75, 87, 109, 110C)

Vespa triloba Fabricius, 1787, Mant. Ins. 1: 290 (type loc.: China (?)).

Odynerus trilobus: Schulthess, 1934, Arb. Morph. Taxon. Entomol. 1: 74 (in key); Sonan, 1938b, Trans. Nat. Hist. Soc. Formosa, 28: 79-80; Yasumatsu, 1950, Icon. Ins. Jpn. 2nd. ed. p. 1456, fig. 4200.

Odynerus emma Sonan, 1929, Trans. Nat. Hist. Soc. Formosa, 19: 535 (♂)(type loc.: Penghu I. (= Hôkô-tô), Taiwan).

Euodynerus trilobus: Vecht and Fischer, 1972, Hym. Cat. (n. ed.), 8: 101; Yamane and Tano, 1987, Trans. Shikoku Entomol. Soc. 18: 341-342.

Japanese names: Jûji-dorobachi (Emma-hime-dorobachi; Emma-dorobachi).

Diagnosis. Body length (h+th+t1+2): 7.5-10.5 mm in ♀, 6.5-8.0 mm in ♂. Fore wing length: 9.5-10.0 mm in ♀, 6.5-9.0 mm in ♂. Structural characters as in the key.

Female. Black, marked with yellow or orange yellow as follows: a basal bar on clypeus, frontal spot, small spot behind each eye, a small marking on mandibular base, antennal scape below, a relatively wide band (medially interrupted) anteriorly on pronotum, tegula except for margins and central spot, parategula, a relatively large spot under wing base, scutellum partly (seen only in the specimens from Yaeyama Is.), dorsal

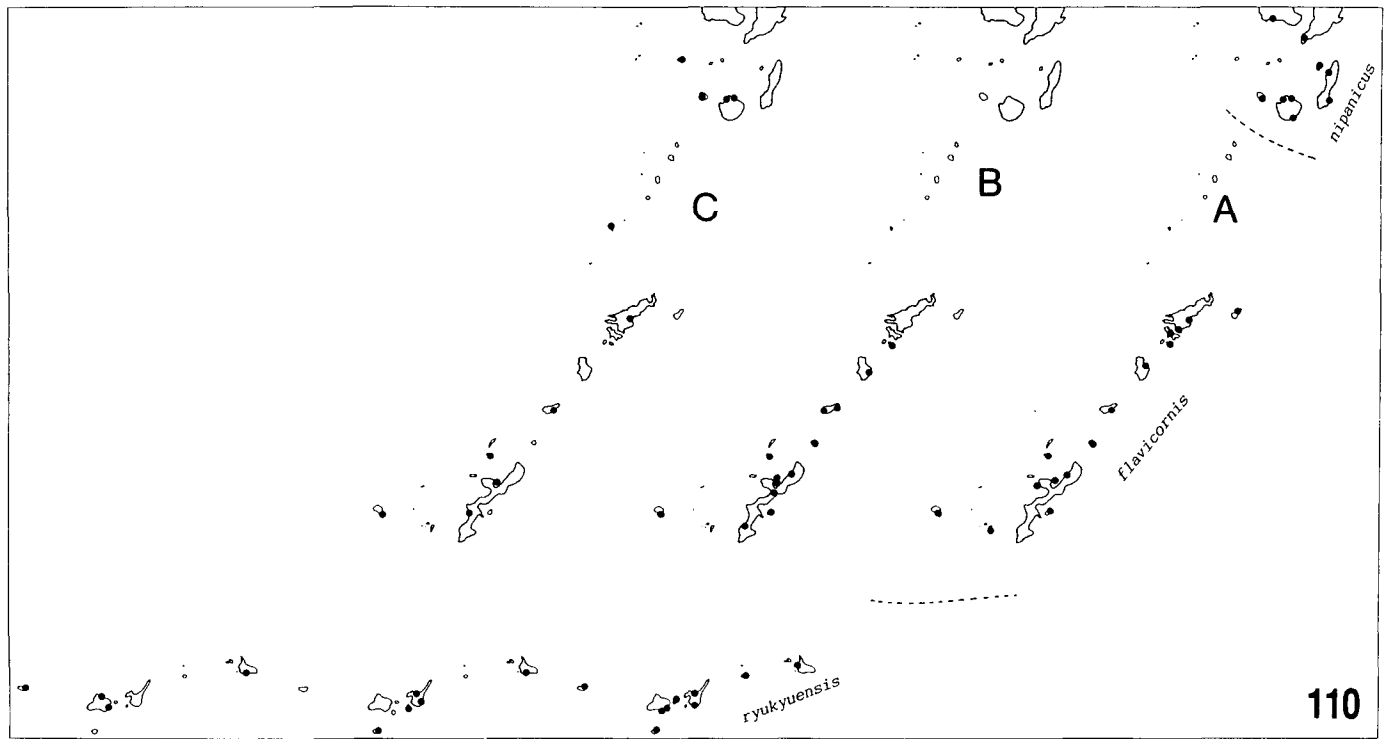

Figs. 110. Distribution of *Euodynerus nipanicus* (A; three subspecies), *Euod. dantici* (B) and *Euod. trilobus* (C) in the Ryukyus.

face of metanotum, dorsolateral face of propodeum partly, laterally dilated band on gastral tergite 1 (the band in the middle slightly incised), slightly sinuated apical bands on tergites 2-5, posterolateral corners of gastral sternites 2-4, apical portion of mid and/or hind femora apically, anterior face of mid coxa (often lost).

Male. Differs from the female as follows: clypeus and mandible entirely yellow; frontal spot connected with clypeus by interantennal yellow mark; ocular sinus sometimes with a yellow stripe in inferior part, gastral tergite 2 with isolated yellow spots laterally; apical band on tergite 2 laterally widened; tergite 6 often with a yellow apical band; sternite 2 with yellow lateral markings which are very large; sternite 2 with a narrow, yellow apical band; sternites 3-5 with posterolateral corners yellow; anterior faces of all legs almost wholly, fore and mid femora below, outer faces of tarsi largely yellow (other parts of legs brownish).

Material examined. Honshû: *Wakayama-ken* - 3 ♂♂, Kôzanji, Tanabe, 4 viii 1965 (K. Iwata).

Island close to Kagoshima-ken-hondo: *Akune-ôshima* - 6 ♂♂, 5 viii 1983 (SKY).

N. Ryukyus: *Kuro-shima* - 1 ♀, Ôsato, 4 ix 1981 (SKY); *Yaku-shima* - 2 ♂♂, Koseta, 17 vii 1972 (K. Kusigemati), 5 ♂♂, Shitogo, 10 viii 1981 (SKY).

C. Ryukyus: *Takara-jima* - 3 ♂♂ 3 ♀♀, 16-19 vii 1964 (A. Tanaka), 3 ♂♂, 29-30 v 1982 (KT), 5 ♂♂, 29 vii 1986 (SI), 1 ♂, 16 viii 1988 (SKY); *Yoron-tô* - 2 ♂♂ 1 ♀, 4-6 vi 1985 (SKY); *Izena-jima* - 1 ♀, Nakada, 1 viii 1967 (T. Kifune); *Okinawa-jima* - 1 ♀, Toyogusuku, 4 viii 1976 (S. Yamauchi);

S. Ryukyus: *Ishigaki-jima* - 1 ♂, 19 iv 1981 (T. Fujisawa); *Iriomote-jima* 1 ♂, Ôhara, 15 v 1981 (AN), 1 ♀, Toyohara, 20 v 1981 (AN), 1 ♂, Ôtomi, 25 vii 1985 (AN), 1 ♀, Toyohara, 26 vii 1985 (AN), 1 ♀, Funaura, 22 vi 1986 (SI), 1 ♀, Uehara, 2 vii 1988 (SKY); *Yonaguni-jima* - 1 ♂, 22-24 vii 1983 (H. Kodama), 2 ♂♂, Sonai, 5 vii 1988 (SKY).

Daitô Is.: *Kitadaitô-jima* - 18 ♂♂ 6 ♀♀, 19 viii 1987 (SI); *Minamidaitô-jima* - 2 ♂♂ 1 ♀, 20 viii 1987 (SI).

Distribution. Honshû; Shikoku(?); Kyûshû; Akune-ôshima; Ôsumi Is. (Kuro-shima; Yaku-shima); Tokara Is. (Takara-jima); Amami Is. (Amami-ôshima; Okinoerabu-jima; Yoron-tô); Okinawa Is. (Izena-jima; Okinawa-jima; Yagaji-jima; Kume-jima); Miyako Is. (Miyako-jima); Yaeyama Is. (Ishigaki-jima; Iriomote-jima; Yonaguni-jima); Daitô Is. (Kitadaitô-jima; Minamidaitô-jima). Taiwan; continental China; Africa.

Taxonomic notes. Although widely distributed in the Palearctic region and northern part of the Oriental region, this species has not been divided into geographical races (Vecht & Fischer, 1972). In at least Japan, the color pattern is relatively stable throughout its range. The slight geographical variation is set off by intrapopulation one. This species is widely distributed in the southern parts of Japan, but seems to be very rare in Honshû and Shikoku.

Biology. Most of the known localities in Japan are restricted to the coast (cf. Nagase, 1981). Iwata (1939b) observed females flying around driftwood thrown up on the eastern shore of southern Taiwan (referred to as *Pseudoepipona trilobus*). Wasps were nesting close to each other in burrows (3-5 cm deep, 6 mm in diam.) dug in the wood. Two or three brood cells and an empty cell were constructed in each burrow. Cell partition was made of red clay mixed with sand, 0.5-1 mm in thickness, and very fragile; it is hardened by cocoon lining. Prey: larvae of Tortricidae(?).

Parasitoid: *Hexachrysis* sp. (Hymenoptera, Chrysididae).

Genus *Ryhynchium* Spinola

Rygchium Spinola, 1806, Ins. Ligur. 1: 84 (type species: *Rygchium europaeum* Spinola, 1806 (= *Vespa oculata* Fabricius, 1781)); Saussure, 1852, Et. Fam. Vesp. 1: 101.

Rhynchium: Vecht, 1963, Zool. Verh. 60: 109.

Japanese names: Ô-dorobachi Zoku (Fukai-dorobachi Zoku).

This genus is an Old World group, comprising relatively large-sized species mainly distributed in Middle East and Africa. A brief diagnosis is given in the key to the Japanese genera. Vecht (1963) mentioned that in the wasps of this genus the scutellum and posterior part of mesoscutum are smooth and at most finely and sparsely punctate. In the Japanese populations of *R. quinquecinctum* (especially of the mainlands), these parts are often distinctly punctate. This fact and his misunderstanding of Vecht's (1963) paper led Sato (1963) to conclude that the single Japanese species is a member of *Anterhynchium*.

Two other forms, very closely related to *quinquecinctum* (Fabricius, 1787), are known from eastern Asia. *R. brunneum* (Fabricius, 1793) was described from Bengal, and has often been considered to be a synonym or a geographical race of *quinquecinctum*. However, Giordani Soika (1986) and Gusenleitner (1988) treated both forms as separate species. Giordani Soika stated, "la descrizione del *quinquecinctum* corrisponde bene a molti esemplari della China, mentre gli esemplari a me noti dell'India, Burma e Tonchino hanno la colorazione del *brunneum*". On the other hand, these two forms have sometimes been treated as synonyms or subspecies of *R. haemorrhoidale* (Fabricius, 1775) (e.g., Dalla Torre, 1904), but at least *quinquecinctum* is specifically separated from *haemorrhoidale* as follows:

Scutellum and posterior part of mesoscutum finely and sparsely punctate (♀ ♂).

Clypeus with fine white hairs only (♂). Narrow longitudinal depression just adjacent to the outer side of each posterior ocellus distinct (♀ ♂). *R. quinquecinctum* (Fab.)

Scutellum in anterior 2/3 and posterior part of mesoscutum almost impunctate (♀ ♂).

Clypeus with dark bristles in addition to fine hairs (♂). Longitudinal depression near each posterior ocellus obscure or absent (♀ ♂). *R. haemorrhoidale* (Fab.)

Rhynchium quinquecinctum (Fabricius)

(Figs. 111-117, 147)

Vespa quinquecincta Fabricius, 1787, Mant. Ins. 1: 288 (type loc.: China (?)).

Rhynchium haemorrhoidale var. *quinquecinctum*: Dalla Torre, 1894, Cat. Hym. 9: 45; 1904, Gen. Ins. 19: 34; Liu, 1936, Peking Nat. Hist. Bull. 11: 109-110; Sonan, 1937, Trans. Nat. Hist. Soc. Formosa, 27: 107-109.

Rhynchium quinquecinctum: Yamane and Tano, 1983, Mem. Kagoshima Univ. Res. Center S. Pac. 4: 122-123; Lee, 1985, Econ. Ins. Fauna China, 30: 142-143, pl. 9, fig. 14.

Japanese names: Fukai-ô-dorobachi (Fukai-dorobachi).

Diagnosis. Female. Body length (h+th+t1+2): 12.5-17.0 mm. Fore wing length: 13.0-15.5 mm. Head subcircular, moderately punctate on vertex and gena, and strongly punctate on frons above supraclypeal area that is almost impunctate. Supraclypeal area with a distinct interantennal vertical keel, which is distichous above. Clypeus pyriform, moderately punctate, with the apex narrowly truncate (Fig. 111); spaces between punctures forming vertical carinae in the middle of the disc. Ocellar region with a narrow longitudinal depression just adjacent to the outer side of each posterior ocellus.

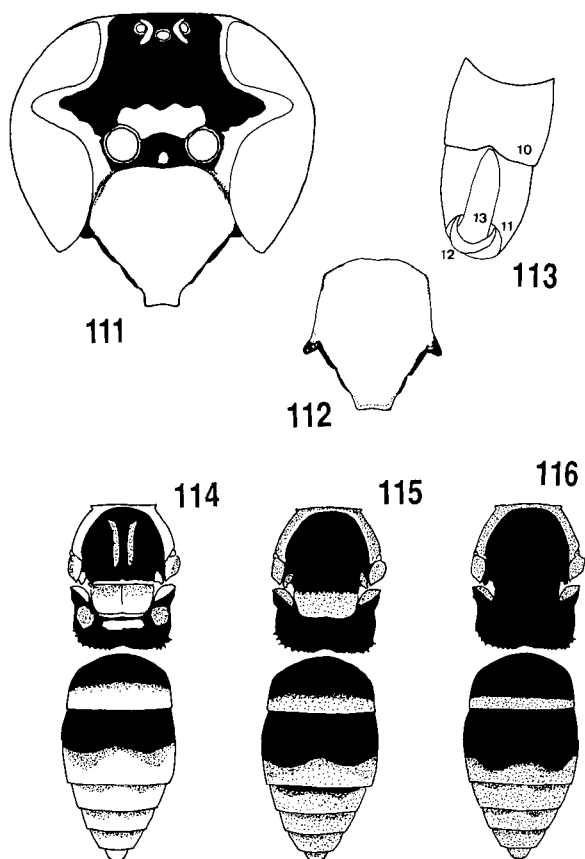

Figs. 111-116. *Rhynchium quinquecinctum*. 111, female head (frontal view); 112, male clypeus; 113, terminal segments of male antenna (from below); 114-116, body color pattern in ssp. *nambu* (114), ssp. *murotai* (115), ssp. *fukaii* (116).

Depression for the cephalic foveae large, distinct, with dense hairs and a longitudinal median keel, and posteriorly well defined by an elevated rim. Anterior vertical face of pronotum smooth, shining; posterior horizontal part and lower lateral part densely punctate; a distinct depression just anteriorly to the posterior pronotal lobe. Mesoscutum strongly and densely punctate in anterior 2/3, finely and sparsely punctate in posterior 1/3; scutellum finely and sparsely punctate. Mesopleuron more coarsely punctate, somewhat reticulate except for epicnemium, which is almost impunctate and well demarcated by epicnemial carina. Metanotum very densely punctate, medially weakly depressed, with blunt lateral projections; posterior vertical face almost impunctate in lower 2/3, dull. Metapleuron transversely striate in upper 1/4 and lower 1/2. Propodeum without a shelf, with spined inferior ridges; dorsal face reticulate; lateral face striate; concavity with a Y-shaped median carina, a triangular area just below metanotum and many striae, and shining. Gastral segments punctate much more finely than alitrunk. Gastral sternite 1 strongly punctate and transversely carinate; sternite 2 distinctly

punctate.

Male. Body length (h+th+t1+2): 9.5-14.5 mm. Fore wing length: 10.0-12.0 mm. Similar to the female. Clypeus much higher than wide, very superficially punctate, with short fine hairs, shallowly emarginate at apex (Fig. 112). Antennal segment 12 very small; the apex of antennal hook (seg. 13) reaching the apex of segment 10 (Fig. 113). Mid femur distinctly emarginate at base.

The population of the Japanese mainlands has often been dealt with as a distinct species, *R. fukaii* Cameron, by authors (e.g., Vecht & Fischer, 1972), but I have concluded that all the Japanese forms are geographical races of *R. quinquecinctum* (Yamane & Tano, 1983).

Key to the Japanese forms of *Rhynchium quinquecinctum*

1. Alitrunk marked with yellow. Apical bands on gastral tergites yellow or orange yellow, not tinged with brown. Metanotum constantly marked with yellow. subsp. *nambuui* Yam.
- Alitrunk marked with dark orange yellow to ferruginous. Apical bands on gastral tergites dark orange yellow, sometimes tinged with brown. Metanotum very often almost wholly black. 2
2. Scutellum usually dark orange yellow in posterior 1/2 - 2/3. In the male the tibiae of all legs with yellow markings on outer faces (outer face of fore tibia often extensively yellow); hind tibia not blackish. subsp. *murotai* Tano
- Scutellar markings much reduced, often lost. Male tibiae usually not marked with yellow; hind tibia often wholly blackish. subsp. *fukaii* Cam.

Rhynchium quinquecinctum fukaii Cameron (Figs. 116, 117)

Rhynchium fukaii Cameron, 1911, Entomologist, 44: 287 (♂) (type loc.: Japan); Yano, 1932, Icon. Ins. Jpn. p. 307; Yasumatsu, 1938, Ins. Jpn. Ill. Icon. Col. Nat. Dep. p. 359; Giordani Soika, 1976, Ann. Hist.-Nat. Mus. Nat. Hung. 68: 292.

Rhynchium haemorrhoidale F.: Matsumura, 1911, Thous. Ins. Jpn. Suppl. 3: 112, no. 684, pl. 39, fig. 16; 1930, Ill. Thous. Ins. Jpn. 2: 14-15, pl. 2, fig. 16 (part); 1931, 6000 Ill. Ins. Jpn.-Emp. p. 16, no. 80.

Odynerus (Rhynchium) haemorrhoidalis var. *fukaii*: Giordani Soika, 1941, Boll. Soc. Venez. Stor. Nat. 2: 261.

Rhygchium haemorrhoidale fukaii: Yano, 1950, Icon. Ins. Jpn. 2nd ed. p. 1455; Ishikawa, 1965, Icon. Ins. Jpn. Col. Nat. Ed. 3: 297, pl. 149, fig. 5 (*Rhynchium*).

Rhynchium haemorrhoidale (F.) ssp. *samurayi* Giordani Soika, 1973, Boll. Mus. Civ. Venez. 24: 119-120 (♀) (type loc.: Tôkyô, Honshû). **Syn. nov.**

Japanese names: Fukai-ô-dorobachi (*Fukai-dorobachi*).

Diagnosis. Female. Black, with yellow and (dark) orange yellow markings. Yellow are clypeus (centrally darker), a line on inner orbit below, a transverse marking on frons and antennal scape below. Other markings are darker, sometimes reddish or brownish: a line on inner orbit above and genal band (complete) connected with it, a pair of curved lines in ocellar region, a transverse marking across vertex (interrupted medially at cephalic

foveae), upper portion of the anterior vertical face of pronotum, posterior horizontal part of pronotum largely, a large spot under wing base, tegula posteriorly, posttegula, scutellum posteriorly (usually lost), irregular markings on metanotum (reddish, often lost), irregular markings on propodeum (reddish), a narrow apical band on gastral tergite 1, wider ones on tergites 2-6, narrow and medially widely interrupted apical bands on sternites 2-4, sternite 5 largely. Antenna except for scape below, mandible largely, apical 2/3 of fore femur, fore tibia, fore tarsus, mid femur in apical 1/2 below are dark orange or rufous.

Male. Similar to the female, but differs in the following points: clypeus wholly lemon yellow; mandible often with a yellow triangular marking; mid and hind tarsi sometimes marked with reddish brown.

Material examined. Honshû: Niigata-ken - 1 ♀, "Echigo", 16 vii 1935 (Nohira), 1 ♀, "Echigo", 3 viii 1940, 1 ♂, "Echigo", 10 ix 1940 (Nohira), 1 ♀, Nagaoka, 26 viii 1951 (Yamazaki), 2 ♀ ♀, Niigata-shi, 27 viii 1963 (YM); Ibaraki-ken - 1 ♀, Tsuchiura, 9 viii 1987 (SKY); Nagano-ken - 1 ♂, Nagano-shi, 15 vii 1968 (T. Kitamura); Wakayama-ken - 2 ♂ ♂, Kôzanji, Kiitanabe, 4 viii 1965 (K. Iwata); Hyôgo-ken - 2 ♂ ♂, Sasayama, Tamba, 30 vii 1964 (K. Iwata); Okayama-ken - 1 ♂, Ukai-gawa, 25 viii 1960 (K. Iwata); Shimane-ken - 1 ♂, Kawatsu, Matsue, 6 viii 1985 (N. Sugiura).

Shikoku: Kôchi-ken - 1 ♂, Monobe, Nankoku, 9 vii 1975 (SI).

Kyûshû: Nagasaki-ken - 1 ♀, Haraguchi, Ômura, 18 vii 1967 (R. Ohgushi); Kagoshima-ken - 1 ♂, Ônejime, Sata, 3 ix 1978 (H. Nagase), 2 ♂ ♂, Kôrimoto, Kagoshima-shi, 6-7 viii 1981 (SKY), 1 ♂, same loc., 26 viii 1981 (SKY).

Distribution. Honshû; Awaji-shima; Shikoku; Kyûshû. Korea (Giordani Soika, 1973); E. Siberia and N. China (Kurzenko, 1984b).

Biology. Nesting biology of this form was studied in Ôsaka-fu, Honshû, by Iwata (1938b, 1980c). Nests are made in bamboo and reed tubes. One to seven (usually 1-3) brood cells are constructed per nest, together with 1-5 empty cells. Nesting proceeds quickly, two or three cells being completed in a day. Entrance plug is rough, not water-resistant. Caterpillars of Pyralidae (more than 2 cm long) are most preferred, and those of Tortricidae are only occasionally hunted. A cell is provisioned with three to ten (usually 6-7) caterpillars.

Parasite: *Pseudoxenos iwatai* (Strepsiptera, Stylopidae). Parasitoids: *Amobia distorta* (Diptera, Sarcophagidae), and a phorid (Diptera).

Rhynchium quinquecinctum murotai Tano (Figs. 115, 147)

Rhynchium fukaii: Yano, 1932, Icon. Ins. Jpn. p. 307; Yasumatsu, 1938, Ins. Jpn. Ill. Icon. Col. Nat. Dep. p. 359.

Rhynchium haemorrhoidale: Matsumura, 1911, Thous. Ins. Jpn. Suppl. 3: 112, pl. 39, fig. 16; Matsumura and Uchida, 1926, Ins. Matsum. 1: 37; 1930, Ill. Thous. Ins. Jpn. 2: 14-15, pl. 2, fig. 16; 1931, 6000 Ill. Ins. Jpn.-Emp. p. 16, no. 80.

Rhynchium quinquecinctum murotai: Yamane and Tano, 1983, Mem. Kagoshima Univ. Res. Center S. Pac. 4: 124, fig. 12 (♀ ♂) (type loc.: Amami-ôshima); Giordani Soika, 1986, Boll. Mus. Civ. Stor. Nat. Venez. 35: 72-73.

Japanese names: Murota-ô-dorobachi (Murota-dorobachi).

Diagnosis. Similar to the preceding subspecies. Scutellum always marked with dark orange or reddish brown, while metanotum only rarely with markings of these colors. In

the male, tibiae and tarsi of all legs testaceous or rufous; tibiae very often extensively yellowish on outer faces.

Material examined. N. Ryukyus: *Naka-no-shima* - 1 ♀, 16 viii 1943 (H100).

C. Ryukyus: *Takara-jima* - 2 ♂♂, 16 viii 1988 (SKY); *Kikai-jima* - 1 ♂1♀, 18 x 1987 (SI); *Amami-ôshima* - 1 ♀, Santarô Pass, 23 vii 1967 (TM), 1 ♂, Sumiyô, 29 vii 1973 (K. Sakamoto), 1 ♂1♀, Sumiyô, 11-13 vii 1981 (YH), 2 ♂♂, Koniya, 22 vi 1987 (SKY), 1 ♀, Nishinakama, 25 vii 1987 (AN), 2 ♂♂, Uttabaru, Kasari, 17-18 x 1987 (SI), 2 ♂♂1♀, Shimmura, Sumiyô, 20-21 x 1987 (SI); *Kakeroma-jima* - 1 ♀, 23 ix 1984 (AN), 1 ♀, Shadon, 24 ix 1984 (AN), 1 ♂1♀, Kanyû, 25 ix 1984 (AN), 4 ♂♂4♀, Osai, 26-27 ix 1987 (SKY), 1 ♀, Nishiamuro, 28 ix 1987 (SKY); *Yoro-shima* - 1 ♂, 13 viii 1987 (M. Tatsuno); *Uke-shima* - 2 ♀♀, 12 viii 1987 (M. Tatsuno); *Tokuno-*

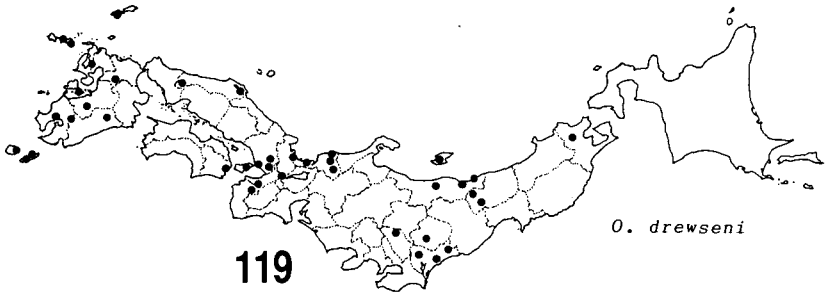
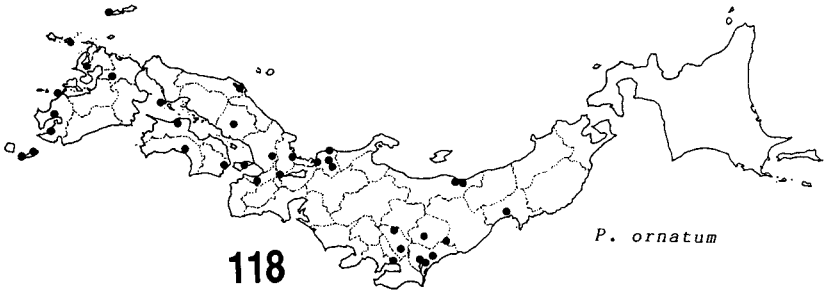
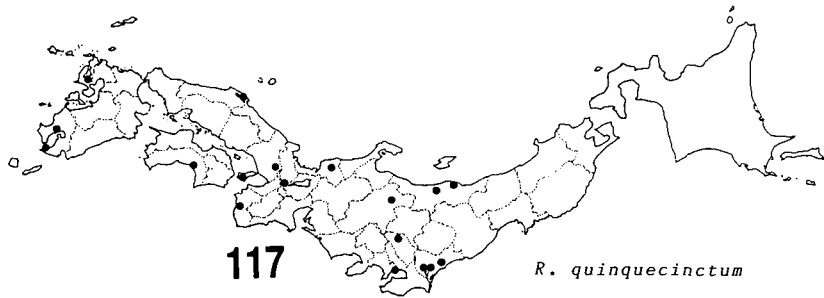

Figs. 117-119. Distribution of *Rhynchium quinquecinctum*, *Pararrhynchium ornatum*, and *Orancistrocerus drewseni* on the Japanese mainlands.

shima - 1 ♂, Kametsu, 13 vii 1980 (Y. Takai), 1 ♀, Miikyô-dake, 6 ix 1983 (M. Ôhara), 1 ♂, Kametoku, 13 vii 1984 (SKY); *Okinawa-jima* - 3 ♂ ♂8 ♀ ♀, "Okinawa" (Sakaguchi), 3 ♂ ♂3 ♀ ♀, "Okinawa", 1923 (Sakaguchi), 2 ♂ ♂, Sashiki, 1 viii 1976 (S. Yamauchi), 1 ♂, Toyogusuku, 4 viii 1976 (S. Yamauchi), 1 ♂ ♂3 ♀ ♀, Naha, 29 ix 1977 (SY), 2 ♂ ♂1 ♀, Kudaken, 30 ix 1977 (SY); 4 ♂ ♂1 ♀, Nakagusuku, 3 x 1977 (SY), 1 ♂, Ogimi, 26 viii 1979 (H. Nagase), 1 ♂, Hyakuna, 1 vii 1981 (AN), 3 ♂ ♂, Hentona, 1-5 vi 1983 (AN), 1 ♂, Sate, 5 vi 1983 (AN), 3 ♂ ♂2 ♀ ♀, Yona, 18 vii 1984 (SKY), 3 ♂ ♂, Hentona, 27-28 vii 1987 (SKY), 1 ♀, Yona, 6 x 1987 (AN), 1 ♀, Nago, 3 x 1987 (AN); *Kouri-jima* - 2 ♂ ♂5 ♀ ♀, 18 x 1988 (Y. Kusui); *Hamahiga-jima* - 3 ♂ ♂, 22 x 1988 (Y. Kusui); *Sezoko-jima* - 1 ♀, 28 v - 1 vi 1982 (Y. Ikimori & Y. Ôhira); *Tokashiki-jima* - 6 ♂ ♂3 ♀ ♀, 11 x 1988 (SKY).

Distribution. Tokara Is. (Naka-no-shima; Takara-jima); Amami Is. (Kikai-jima; Amami-ôshima; Kakeroma-jima; Yoro-shima; Uke-shima; Tokuno-shima; Okinoerabu-jima; Yoron-tô); Okinawa Is. (Okinawa-jima; Kouri-jima; Yagaji-jima; Sezoko-jima; Hamahiga-jima; Tokashiki-jima; Kume-jima).

Biology. Kinjo (in Azuma et al. 1987, p. 188) mentioned nesting sites of this species in the Ryukyus (see below).

Parasite: *Pseudoxenos iwatai* (Maeta, 1980; Kifune & Yamane, 1985).

Rhynchium quinquecinctum nambui Sk. Yamane (Figs. 114, 147)

Rhynchium fukaii: Yano, 1932, Icon. Ins. Jpn. p. 307; Yasumatsu, 1938, Ins. Jpn. Ill. Icon. Col. Nat. Dep. p. 359.

Rhynchium haemorrhoidale: Matsumura, 1911, Thous. Ins. Jpn. Suppl. 3: 112, pl. 39, fig. 16; Matsumura and Uchida, 1926, Ins. Matsum. 1: 37; Matsumura, 1931, 6000 Ill. Ins. Jpn.-Emp. p. 16, no. 80.

Rhynchium quinquecinctum nambui: Yamane and Tano, 1983, Mem. Kagoshima Univ. Res. Center S. Pac. 4: 123 (♀ ♂)(type loc.: Iriomote-jima, Yaeyama Is.).

Anterhynchium flavomarginatum umenoi: Kinjo, 1987, in S. Azuma ed., Field Guide-book to the Insects of Okinawa, 3: 188 (misidentification).

Japanese names: Nambu-ô-dorobachi (Nambu-dorobachi).

Diagnosis. The pattern of body markings is similar to that of the subspecies *murotai*, but the markings are much paler, especially on head and thorax. Female mandible usually with a basal yellow marking. Scutellum and metanotum constantly marked with yellow. Propodeum often with orange or reddish brown markings.

Material examined. S. Ryukyus: *Miyako-jima* - 2 ♀ ♀, Hirara, 18 vii 1987 (SKY), 1 ♀, Hirara, 28 vi 1988 (SKY); *Irabu-jima* - 1 ♂, Sarahama, 28 iv 1981 (T. Fujisawa); *Tarama-jima* - 2 ♂ ♂1 ♀, 19-20 vii 1987 (SKY), 1 ♂, 28 vi 1988 (SKY); *Minna-jima* - 2 ♂ ♂, 29 vi 1988 (SKY); *Ishigaki-jima* - 1 ♂, vii 1922 (S. Hirayama), 1 ♀, viii 1922 (S. Hirayama), 1 ♀, 11 vii 1973 (H. Takizawa), 2 ♂ ♂, Ishigaki-shi, 25 iii - 1 iv 1973 (J. Nakayama), 2 ♀ ♀, same loc., 10 x 1977 (SY), 1 ♀, Yonehara, 16 iv 1981 (KB), 2 ♂ ♂1 ♀, Ishigaki-shi, 18 iv 1981 (T. Fujisawa), 1 ♂ ♂1 ♀, Ibaruma, 14 x 1987 (AN), 2 ♂ ♂, Omoto-dake, 3 vii 1988 (K. Nakamine), 3 ♂ ♂, Banna-dake, 3-8 vii 1988 (K. Nakamine), 1 ♂, Banna-dake, 4 vii 1988 (SKY); *Taketomi-jima* - 5 ♂ ♂, 8 vii 1988 (K. Nakamine); *Kuroshima* - 2 ♂ ♂, 23 vii 1987 (SKY); *Iriomote-jima* - 2 ♂ ♂, 17 iv 1962 (G. Kuno), 1 ♀, Komi, 11 viii 1972 (TN), 1 ♂ ♂1 ♀, Funaura, 5-9 x 1977 (SY), 1 ♀, Urauchigawa, 6 x 1977 (SY), 1 ♂, 16 iv 1978 (K. Ôhara), 2 ♂ ♂, Sonai, 20 iv 1981 (T. Fujisawa), 2 ♂ ♂, Ôtomi, 17 v 1981 (AN), 1 ♀, Ôhara, 24 v 1981 (AN), 2 ♀ ♀, Ôhara, 7 viii 1981 (AN), 1 ♀, Ôtomi, 28 iv 1982 (AN), 1 ♀, Ôhara, 28 iv 1982 (AN), 2 ♂ ♂, Toyohara, 29 iv 1982 (AN), 2 ♂ ♂, Ôtomi, 29 vii 1983 (AN), 1 ♀, Komi, 31 vii 1983 (AN), 1 ♀, Toyohara, 26 vii 1985 (AN), 1 ♀, Ôtomi, 27 vii 1985 (AN), 3 ♂ ♂, Amitori, 30 vii - 1 viii 1985 (AN), 2 ♂ ♂, Ôhara, 20 vi 1988 (K. Nakamine), 1 ♀, Uehara, 2 vii 1988 (SKY); *Uchibanare-jima* - 2 ♀ ♀, 3-4 viii 1988 (Y. Fujii); *Hateruma-jima* - 10 ♂ ♂1 ♀, 1-2 vii 1988 (SKY), 2 ♀ ♀, Naishi, 2 x 1988 (SI); *Yonaguni-jima* - 1 ♀, Hikawa, 26 viii 1978 (TN), 1 ♂, Sonai, 5 vii 1988 (SKY).

Distribution. Miyako Is. (Miyako-jima; Irabu-jima); Tarama Is. (Tarama-jima; Minna-jima); Yaeyama Is. (Ishigaki-jima; Taketomi-jima; Kuro-shima; Iriomote-jima; Uchibanare-

jima; Hatoma-jima; Hateruma-jima; Yonaguni-jima).

Biology. Kinjo (in Azuma, 1987) states that in the Ryukyus this species nests in hollowed plant stems, abandoned mud nests of other wasps or tunnels dug in plant material (referred to as *Anterhynchium flavomarginatum*).

Parasite: *Pseudoxenos iwatai* (Maeta, 1980; Kifune & Yamane, 1985).

Genus *Anterhynchium* Saussure

Anterhynchium Saussure, 1863, Mem. Soc. Phys. Hist. Nat. Geneve, 17: 205 (name for *Rygmium* or *Rhynchium*, I Division of Saussure, 1852, 1855)(type species: *Rygmium synagroides* Saussure, 1852, designated by Vecht, 1963); Vecht, 1963, Zool. Verh., 60: 58 (in key), 73, 74; Vecht and Fischer, 1971, Hym. Cat. (nov. ed.), 8: 105.

Japanese name: Futaobi-dorobachi Zoku.

A good diagnosis for this genus was given by Vecht (1963), who divided it into three subgenera, *Dirhynchium* Vecht, *Anterhynchium* Saussure, and *Epidynerus* Giordani Soika. The two Japanese species (*flavomarginatum* and *melanopterum*) belong to *Dirhynchium*, which is characterized by the dense transverse striation on the narrow basal part of gastral sternite 1 and very coarse punctation on the basal part of gastral tergites 3 to 5 (the latter condition can be seen when the gaster is unusually extended). In northeastern Asia three very closely related species are known to occur, for which a key will be given below.

Key to the species of *Anterhynchium* in northeastern Asia

1. Depression bearing cephalic foveae obscure (♀). Aedeagal shaft only slightly narrower than aedeagal tip (♂). Clypeus wider than high (♀). Scutellum and metanotum almost always without orange markings (♀ ♂). *A. melanopterum* Yam.
- Cephalic foveae situated in a large, posteriorly well defined depression (♀). Aedeagal shaft much thinner (♂). Shape of clypeus variable. Scutellum and/or metanotum often marked with yellow or orange. 2
2. Clypeus nearly as wide as high (♀); its apical emargination rather wide and deep, and lateral teeth divergent (♀ ♂). *A. flavopunctatum* (Sm.)
- Clypeus higher than wide (♀); its apical emargination narrower and shallower (♀ ♂). *A. flavomarginatum* (Sm.)

Anterhynchium flavomarginatum (Smith)

(Figs. 120, 122, 124, 126-142, 144-146)

Rhynchium flavo-marginatum Smith, 1852, Trans. Entomol. Soc. Lond. (2): 35 (♂)(type loc.: China).

Odynerus nigrifrons Smith, 1857, Cat. Hym. Brit. Mus. 5: 62 (♀)(type loc.: N. China).

Anterhynchium flavomarginatum: Vecht, 1963, Zool. Verh. 60: 79; Yamane and Tano, 1983, Mem. Kagoshima Univ. Res. Center S. Pac., 4: 124, 125.

Japanese name: Ô-futaobi-dorabachi.

Diagnosis. Body length (h+th+t1+2) 12.5 mm in ♀, 9.0-12.5 mm in ♂. Fore wing

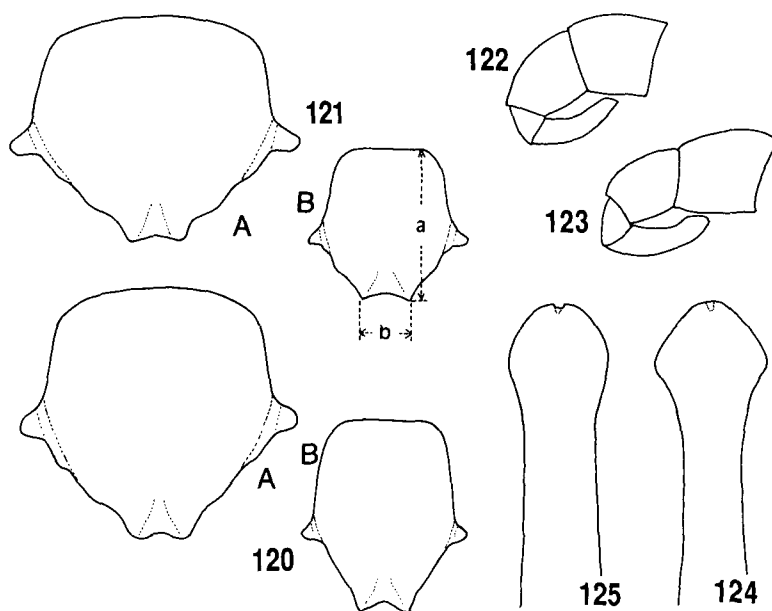

Figs. 120-125. Morphological characters in the Japanese *Anterhynchium* (after Yamane, 1981). 120, 122, 124, *A. flavomarginatum*; 121, 123, 125, *A. melanopterum*. 120, 121, clypeus (A, ♀; B, ♂); 122, 123, segments 10-13 of male antenna (original); 124, 125, apical part of penis.

length 12.0-14.5 mm in ♀, 8.5-11.5 mm in ♂. This is a polytypic species comprising 13 subspecies and widely distributed in southern and eastern Asia. Up to now eight subspecies have been described and recorded from Japan (Yamane, 1981; Yamane & Tano, 1983). Most of them, known from the Ryūkyū islands, have a more or less wide range of variation in color pattern. Although in some cases the subspecies may be recognized only statistically, this treatment is useful in discussing the faunal relations among islands.

The ground color of this species is black, sometimes partly replaced with brown or reddish brown. Body markings vary from sulphur yellow through yellow and orange yellow to reddish brown in color. Generally the markings on the head and alitrunk are paler than those on the gaster. Main markings are explained below to facilitate the description of the geographical races.

1. Clypeus: ground color much reduced in ♀ and almost lost in ♂; in ♀ the black portions will be called *black clypeal markings* for convenience (in *tsushimarium* only basal part pale yellow); the black markings (sometimes replaced with brown) are generally developed in *hanedai*, *amamense* and *insulicola*, much reduced in *umeno* and *procella*, but vary in development even in a single population.

2. Mandibular stripe: only seen in ♂ of *umeno*.

3. Frontal marking: situated just above the antennal insertion, rarely connected with the supraclypeal marking, when the latter is present.

4. Supraclypeal marking: usually very small and often lost.

5. Stripe on each ocular sinus along the lower inner margin of eye: always present in

♂ except in *tsushimarum*, but variable in size; in ♀ only seen in *umeno*.

6. Stripe on antennal scape below: seen in all the forms, and variable in color.

7. Genal band (*umeno*), genal stripe or spot (other forms): usually upper genal stripe alone is seen; lower spot is seen only in ♀ of *procella*.

8. Pronotal marking: large and variable in size.

9. Pair of median stripes on mesoscutum: sometimes weakly developed, but usually absent.

10. Lateral stripe on mesoscutum along the base of each tegula: usually undeveloped, most strongly developed in ♀ of *micado* and *procella*.

11. Marking on tegula: variable in shape.

12. Parategula: usually wholly yellow, in a few forms the yellow extending forward as the lateral stripe of mesoscutum.

13. Mesopleural spot under each wing base: usually present, but often lost in ♀ of *hanedai*.

14. Marking on scutellum: always seen, sometimes divided into two.

15. Stripe on metanotum (postscutellum).

16. Propodeal spots: variable in size and shape, and completely lost in some forms.

17. Apical bands on gastral tergites 1-5 (or 1-6 in ♂): bands on first two tergites are always complete except in *tsushimarum* in which bands are nearly wholly lost, but those on the subsequent tergites may be replaced with brown or dark reddish brown, or lost.

18. Spots on sternite 2 (also 3 in ♂), and apical bands on sternites 3-5 (or -6 in ♂): these markings are usually replaced with brown or lost.

19. Lateral spots on male mid and hind coxae: in some forms completely lost; other parts of legs in ♂ are also marked with yellow, but their position and size are highly variable even in a single population.

Key to the Japanese subspecies of *A. flavomarginatum*

1. Body almost entirely black. Yellowish color confined to the basal half of clypeus (clypeus entirely yellow in ♂), and to frontal spot (in a few specimens pronotum and gaster with minute pale markings). Wings blackish. Tsushima. subsp. *tsushimarum* (Yasum.)
- Body marked with yellow or orange; at least gastral tergites 1 and 2 with the complete apical bands. 2
2. Ocular sinus with yellow stripe (♀). Mandible with yellow stripe (♂). Antennal scape almost entirely yellow (♂). Genal band developed (♀ ♂). Yaeyama Is. subsp. *umeno* (Yasum.)
- Ocular sinus without yellow stripe (♀). Mandible without yellow stripe (♂). Antennal scape brownish or blackish above (♂). Gena with upper stripe (♀ ♂). 3
3. Antennal flagellum brownish or ferruginous even on upper face (especially in ♀; darker in ♂). Mesopleural spot often lost (♀). Propodeum without yellow markings (♀; ♂ often with such markings). Body markings darker, partly brownish (♀; somewhat paler in ♂). Okinawa Is. subsp. *hanedai* Tano
- Antennal flagellum black above (♀ ♂). Mesopleural spot present (♀). Propodeum often with yellow markings dorsolaterally (♀ ♂). Body markings yellow or orange yellow (♀; paler in ♂). 4

4. Only tergites 1 and 2 with distinct yellow apical bands; other tergites completely black or with dark or blackish brown bands which are inconspicuous (♀ ♂). Last tergite and sternite almost entirely black (♀). Antennal pedicel usually black above (♂). Hokkaidô, Honshû, Awaji-shima, Shikoku, Kyûshû, etc. subsp. *micado* (Kirsch)
- Apical bands on gastral tergites 3-5 (or -6 in ♂) also yellow or orange yellow; (orange) yellow sometimes replaced with brown or reddish brown, but the bands usually clearly discernible (♀ ♂). Last tergite and sternite sometimes ferruginous, at least partly (♀). Antennal pedicel often ferruginous above (♂). 5
5. Markings on head and thorax sulphur yellow (♀ ♂). Yellow bands on tergites usually complete (♀ ♂); that on tergite 1 distinctly widened laterally, often with lateral prongs anteriorly (♀ ♂). Akuseki-jima; Takara-jima. subsp. *sulphreum* Yam.
- Markings on head and thorax yellow or orange yellow (at most pale yellow in ♂). Apical bands on tergites 3-5 (-6 in ♂) often brownish or ferruginous (♀ ♂). 6
6. Last tergite almost entirely ferruginous (♀). Orange yellow apical bands on tergites 3-5 usually complete (♀). Antennal pedicel above usually black (♂). Mid and hind coxae usually without yellow lateral spots (♂). Kuchi-no-shima; Naka-no-shima; Suwanose-jima. subsp. *insulicola* Yam.
- Last tergite black, at least partly (♀). Apical bands on tergites 3-5 often replaced with brown or reddish brown (♀). Antennal pedicel above often ferruginous (♂). Mid and hind coxae often with yellow lateral spots (♂). 7
7. Yellow apical bands on tergite 1 wider, widened laterally, often with lateral prongs anteriorly (♀ ♂). Gena without lower yellow spot (♀). Yellow lateral stripes on mesoscutum much reduced or lost (♀ ♂). Black clypeal markings often developed (♀). Amami-ôshima, Okinoerabu-jima, etc. subsp. *amamense* Tano
- Yellow apical band on tergite 1 narrower, narrowed laterally (♀ ♂). Gena often with lower yellow or orange spot in addition to the upper stripe (♀; not seen in ♂). Mesoscutum with lateral yellow stripes (usually in ♀, sometimes in ♂). Black clypeal markings much reduced (♀). Mi-shima Is.; Uji Is. subsp. *procella* Yam.

Anterhynchium flavomarginatum micado (Kirsch)

(Figs. 133, 142, 144, 145, 148)

Rhynchium ardens Smith, 1873, Trans. R. Entomol. Soc. Lond. 1873: 196 (♀)(type loc.: Nagasaki, Kyûshû)(primary homonym of *Rh. ardens* Walker, 1871).

Odynerus (Leionotus) micado Kirsch, 1878, Mitt. Zool. Mus. Dresden, 3: 380 (♀)(type loc.: Japan).

Rhygchium (!) *micado*: Yasumatsu, 1950, Icon. Ins. Jpn. (2nd ed.), p. 1455, fig. 4197.

Rhynchium japonicum Dalla Torre, 1894, Cat. Hym. 9: 46 (new name for *Rh. ardens* Smith); Yano, 1932, Icon. Ins. Jpn. (1st ed.), p. 306, fig. 594; Yasumatsu, 1938, Ins. Jpn. Ill. Icon. Col. Nat. Dep., p. 360, pl. 161, fig. 631-632.

Rhynchium mandarineum Sauss.: Matsumura, 1911, Thous. Ins. Jpn. Supple 3, p. 113, no. 685 (*mandarinum* !); 1930, Ill. Thous. Ins. Jpn. 2: 15, pl. 2, fig. 17; 1931, 6000 Ill. Ins. Jpn. p. 16, no. 81.

Rhynchium varipes Pérez, 1905, Bull. Mus. Hist. Nat. Paris, 11: 25, 85 (♀)(type loc.: Yokohama, Honshû).

Anterhynchium flavomarginatum micado: Vecht, 1963, Zool. Verh. 60: 77 (in key), 80; Ishikawa, 1965, Icon. Ins. Jpn. Col. Nat. Ed. 3: 297, pl. 149, fig. 6; Yamane, 1981, Trans. Shikoku Entomol. Soc. 15: 225 (in key); Yamane and Tano, 1983, Mem. Kagoshima Univ. Res. Center S. Pac., 4: 126 (in key), 131, figs. 21, 30.

Japanese names: Ô-futaobi-dorobachi (Futo-futaobi-dorobachi).

Diagnosis Female. Body markings are yellow or orange yellow. Yellowish are: clypeus

with the apical margin brown and the lateral and lower margins narrowly black, frontal spot, stripe behind eye, antennal scape below, dorsal part of pronotum except posterior 1/3, median stripes on mesoscutum (rarely), parategula, lateral stripes on mesoscutum (rarely complete), anterior and inner margins of tegula, scutellum largely, mesopleural spot, metanotum largely, irregular marking(s) on each side of dorsal part of propodeum, apical bands on gastral tergites 1 and 2 (rarely also on tergite 3), marking on each postero-lateral corner of sternite 2. Apical margins of tergites 3-5 usually black or dark ferruginous; only very rarely tergite 3 with a yellowish apical band. Antenna black; scape above and flagellum below brownish. Mandible ferruginous. All the legs ferruginous to dark brown. Wings brownish hyaline.

Male. Very similar to the female in coloration, but differs from the latter in the following details: clypeus without black rims; ocular sinus usually with a short yellow stripe; yellow markings on scutellum and metanotum often reduced to a varying extent (completely lost in one specimen from Kagoshima); outer faces of fore and mid femora and tibiae with yellow apical spots (these spots sometimes very large, and in such cases femur and tibia of hind leg also extensively yellowish).

Material examined. Honshû: *Yamagata-ken* - 1 ♀, Nan'yô-shi, 20 vii 1980; *Niigata-ken* - 1 ♂, Senami, 30 vi 1979 (KB), 2 ♂ ♂, same loc., 20 vi 1981 (KB), 11 ♂ ♂ 4 ♀ ♀, same loc., 16-23 vii 1981 (KB), 2 ♂ ♂, same loc., 28 viii 1981 (KB), 1 ♂ 5 ♀ ♀, same loc., 3-11 ix 1981 (KB), 1 ♀, same loc., 25 vii 1983 (KB), 1 ♂, same loc., 30 vi 1984 (KB), 1 ♀, same loc., 26 ix 1984 (KB), 1 ♂, Kurokawa, 27 vii 1979 (KB), 1 ♀, same loc., 25 ix 1981 (KB), 1 ♀, same loc., 18 x 1984 (KB), 1 ♀, Shibata, 12 viii 1979 (HI), 3 ♂ ♂, Suibara, 30 v - 3 vi 1978 (A. Seino), 1 ♀, Nagaoka, 29 viii 1952 (H. Kozaki); *Nagano-ken* - 1 ♂, Habiro, Ina, 14 viii 1962 (YM), 1 ♂, Amori, Nagano-shi, 24 viii 1979 (T. Fujisawa); *Tochigi-ken* - 1 ♀, Shimozuke, Ôtawara, 10 viii 1949 (Usuba); *Chiba-ken* - 1 ♂ 1 ♀, Yokoto, 3 ix 1981 (J. Tsukahara), 1 ♀, Shirako, Ôami, 31 vii 1983 (M. Ôhara); *Saitama-ken* - 1 ♂ 1 ♀, Ageo, 31 vii 1980 (T. Sunose), 4 ♂ ♂, same loc., 23 vii 1983 (T. Sunose); *Ibaraki-ken* - 2 ♂ ♂, Tsuchiura, 29 viii 1976 (SKY); *Gifu-ken* - 1 ♂, Hongô-chô, Seki, 19 viii 1976 (Y. Takai), 1 ♂ 1 ♀, same loc., 31 vii - 5 viii 1982 (Y. Takai), 1 ♂, Horado, 7 viii 1982 (Y. Takai); *Wakayama-ken* - 3 ♀ ♀, Koza, 25 ix 1974 (S. Takagi); *Kyôto-fu* - 3 ♀ ♀, Gosho, 12 vii 1955 (K. Iwata); *Hyôgo-ken* - 1 ♀, Sasayama, Tamba, 31 vii 1953 (K. Iwata), 17 ♂ ♂, same loc., 2-6 vi 1964 (H. Katayama), 1 ♂, same loc., 5 vii 1967 (K. Iwata), 1 ♀, same loc., 19 x 1966 (H. Katayama); *Awaji-shima* - 3 ♀ ♀, 18-19 viii 1954 (T. Mori); *Ôsaka-fu* - 1 ♂, Iwawaki, Kawachi, 6 vi 1964 (H. Katayama); *Shimane-ken* - 1 ♂, Mt. Dake, Matsue, 15 vii 1985 (N. Sugiura), 1 ♀, Mt. Makuragi, 28 viii 1985 (M. Goubara).

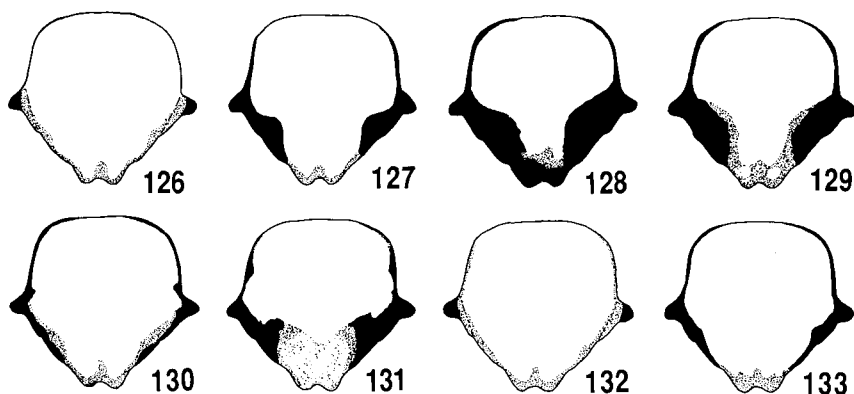

Figs. 126-133. Color pattern of female clypeus in the Ryûkyû subspecies of *Anterhynchium flavomarginatum* (after Yamane & Tano, 1983). 126, ssp. *umenoii*; 127, 128, ssp. *hanedai*; 129, ssp. *amamense*; 130, ssp. *sulphreum*; 131, ssp. *insulicola*; 132, ssp. *procella*; 133, ssp. *micado*.

Shikoku: *Kôchi-ken* - 1 ♂, Asakura, Kôchi-shi, 5 vi 1974 (SI), 1 ♀, Okoyama, Nankoku, 17 ix 1976 (SI); *Kagawa-ken* - 1 ♀, Yashima, 14 viii 1976 (KB).

Kyûshû: *Fukuoka-ken* - 2 ♀ ♀, Kurogi, 27-28 vii 1983 (Y. Takai); *Kumamoto-ken* - 1 ♂, Kagami, 31 v 1982 (M. Maeda), 1 ♀, same loc., 17 vii 1982 (M. Maeda), 1 ♀, same loc., 30 vii 1982 (M. Maeda); *Nagasaki-ken* - 1 ♀, Haraguchi, Ômura, 17 ix 1967 (R. Ohgushi); *Ôita-ken* - 1 ♂, Saeki, 23 vii 1954 (K. Iwata); *Miyazaki-ken* - 1 ♀, Omata, 15 vii 1954 (K. Nohara), 1 ♂, Uchiiumi, 20 vii 1954 (K. Yoshida), 1 ♀, Maruno, 21 vii 1954 (S. Kawamura); *Kagoshima-ken* - 7 ♂ ♂ 1 ♀, Taguchi, Kirishima, 3 vii 1981 (SKY), 1 ♀, Jingû, Kirishima, 23 vii 1981 (SKY), 1 ♂, Shiroyama, Kagoshima-shi, 5 vi 1981 (K. Sakamoto), 15 ♂ ♂ 5 ♀ ♀, same loc., 4-10 vii 1981 (SKY), 4 ♂ ♂ 2 ♀ ♀, same loc., 30 vii 1981 (SKY), 1 ♀, same loc., 6 ix 1982 (SKY), 23 ♂ ♂ 4 ♀ ♀, Kôrimoto, Kagoshima-shi, 4-7 viii 1981 (SKY), 1 ♀, same loc., 13 vii 1981 (M. Maeda), 5 ♂ ♂ 1 ♀, same loc., 17 viii 1981 (SKY), 4 ♂ ♂ 1 ♀, same loc., 22-26 viii 1981 (SKY), 7 ♂ ♂ 2 ♀ ♀, Meiwa, Kagoshima-shi, 15 viii 1981 (SKY), 2 ♀ ♀, Sakamoto, Kagoshima-shi, 20-24 ix 1981 (S. Higashi), 1 ♀, same loc., viii 1982 (S. Higashi), 1 ♀, Kekura, Kagoshima-shi, 20 ix 1981 (SKY), 1 ♀, nr Yamakawa, 6 viii 1984 (M. Maegata), 1 ♀, Kaimon-dake, 26 viii 1986 (SKY), 1 ♀, Takakuma (800 m alt.), 31 vii 1983 (KT), 2 ♂ ♂ 2 ♀ ♀, Kôyama, 24 v 1979 (emerged from a nest; H. Nagase), 1 ♂, Sata-chô, 10 vi 1979 (H. Nagase).

Gotô Is. (Nagasaki-ken): *Aka-shima* - 2 ♀ ♀, 17 viii 1976 (J. Nakayama).

Islands close to Kagoshima-ken-hondo: *Naga-shima* - 2 ♂ ♂, Shoura, 27 viii 1984 (SKY); *Take-shima* - 3 ♂ ♂, 28 viii 1984 (SKY); *Kamikoshiki-jima* - 2 ♀ ♀, Sato, 5-6 ix 1984 (M. Maegata); *Shimokoshiki-jima* - 5 ♂ ♂, Kashima, 5 viii 1986 (SI).

N. Ryukyus: *Tane-ga-shima* - 1 ♀, Ikeno, 21 vii 1984 (S. Watahiki), 1 ♀, Urata, 24 vii 1984 (S. Watahiki), 1 ♀, Hamada, 2 viii 1984 (SKY), 1 ♀, Kamome, 5 viii 1986 (M. Tatsuno); *Mage-shima* - 1 ♂, 22 vii 1984 (S. Watahiki); *Yaku-shima* - 1 ♀, Kurio, 2 xi 1975 (F. Komai), 4 ♂ ♂ 4 ♀ ♀, Miyanouura, 8-11 viii 1981 (SKY), 1 ♂, same loc., 28 vi 1982 (SI), 1 ♀, same loc., 24 viii 1982 (SI), 2 ♂ ♂ 1 ♀, Kusugawa, 9 viii 1981 (SKY), 1 ♂ 1 ♀, Onoaida, 27-29 vii 1982 (SI); *Kuchinoerabu-jima* - 2 ♀ ♀, Hommura, 20 vii 1989 (SKY).

Distribution. Hokkaidô (S. & C. part, Endou, 1977); Honshû; Sado-ga-shima; Awaji-shima; Izu Is. (To-shima); Shikoku; Kyûshû; Gotô Is. (Aka-shima); Chikuzen-okino-shima; Naga-shima Is. (Naga-shima; Take-shima); Koshiki-jima Is. (Kami- & Shimo-koshiki-jima); Ôsumi Is. (Tane-ga-shima; Mage-shima; Yaku-shima; Kuchinoerabu-jima).

Taxonomic notes. According to Smith's description, *Rhynchium ardens* (= *Rh. japonicum* D.T.) has a yellow fascia on gastral tergite 3. Vecht (1963) mentioned that *japonicum* may therefore prove to be subspecifically different from *micado*. Since specimens with an apical band on tergite 3 do occur (though rarely) in the population of Kyûshû, I consider such specimens to represent variations within the subspecies *micado*. Vecht (1963) recorded a female of "typical" *micado* from Korea, but Korean specimens (subsp. *koreanum* Sk. Yamane) differs from *micado* by the darker mandible, much reduced pronotal markings, wholly black scutellum, etc. (Yamane, 1981). Many specimens collected on Yaku-shima are intermediates between the subspecies *micado* and *procella*, and a few are typical *procella*. Since Yaku-shima is connected with Kyûshû by liners, there may be some possibility that *micado*-type individuals have invaded from Kyûshû and mixed with indigenous individuals belonging to *procella*.

Biology. This form is one of the most common eumenid wasps in Japan. Its biology has been studied by Iwata (1938b, *Rhygchium japonicum*), Tsuneki (1970) and Itino (1986a, b). The female wasps construct their nests in bamboo and reed tubes, in tunnels in wood bored by coleopterans, and sometimes in old mud cells of other wasps such as *Oreumenes decoratus*, *Orancistrocerus drewseni* and *Scelifron madraspatanum* (Iwata, 1980c; Ônuma, 1989c). A nest comprises 1-9 brood and some empty cells (Iwata, 1938b). Itino (1986a) reported an average of 2.2 cells per nest (241 trap nests were examined) in Kyôto. One female may make several nests. The cells are separated with mud partitions and each cell is mass-provisioned with 3-21 (mean: ca. 8) larvae of Microlepidoptera (Pyrilidae and Tortricidae) as prey. Maternal care for young is generally not observed. Univoltine in

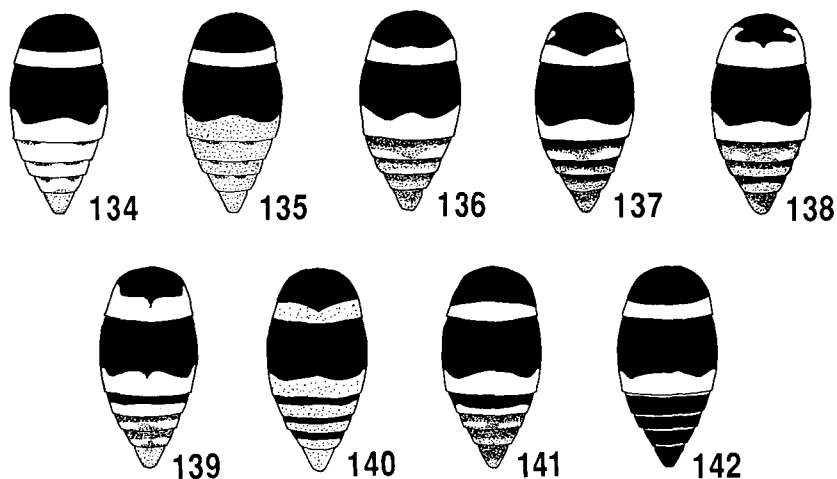

Figs. 134-142. Color pattern of female gaster in the Ryūkyū subspecies of *Anterhynchium flavomarginatum*. 134, ssp. *umenoi*; 135, ssp. *hanedai*; 136-138, ssp. *amamense*; 139, ssp. *sulphreum*; 140, ssp. *insulicola*; 141, ssp. *procella*; 142, ssp. *micado*.

Kyōto (Itino, 1986b), but the very long flying period (early June to mid-October) suggests the occurrence of two generations per year in at least southern parts of Japan.

Parasite: *Pseudoxenos iwatai* (Strepsiptera, Stylopidae). Parasitoids: *Macrosiagon nasuta* (Coleoptera, Rhipiphoridae), *Megaselia* sp. (Diptera, Phoridae), *Amobia distorta* (Dipt., Sarcophagidae), a chrysidid wasp, *Acroricnus ambulator*, *Campoplex* sp. (Hym., Ichneumonidae) (Itino, 1986a), *Nematopodius* sp. (Hym., Ichneumonidae), and *Melittobia acasta* (Hym., Eulophidae) (Yamane & Maeta, unpubl.).

Anterhynchium flavomarginatum tsushimarum (Yasumatsu)
(Fig. 144)

Rhynchium flavopunctatum Smith forma *tsushimarum* Yasumatsu, 1935, Mushi 8: 86 (♀) (type loc.: Shimo-agata, Tsushima Is.).

Anterhynchium (*Dirhynchium*) *flavomarginatum tsushimarum*: Vecht, 1963, Zool. Verh. 60: 77 (in key); Ishikawa, 1970, Mem. Nat. Sci. Mus. Tokyo 3: 269-271, pl. 22; Yamane, 1981, Trans. Shikoku Entomol. Soc. 15: 223-224 (in key).

Diagnosis. Female. Body almost wholly black. The following parts are yellow: large basal mark of clypeus, frontal spot, a pair of short lines on the horizontal part of pronotum anteriorly (often lost), medially widely interrupted apical bands on gastral tergites 1 and 2 (these bands are very narrow and often lost). Mandibles, antennal scape below, femora of all legs apically, tibiae and tarsi of all legs partly dark ferruginous. Mandibles and tibiae often wholly black. Wings blackish hyaline.

Male. Very similar to the female in coloration. Clypeus almost wholly and antennal scape below yellow. In one specimen the yellow pronotal marking and apical bands on tergites 1 and 2 are rather developed.

Material examined. Tsushima Is. (Nagasaki-ken): 1 ♀, Sumo, 9 x 1959 (YM); *Kami-agata* - 1 ♀, Uchiyama (140 m alt.), 1 ♂, Ōboshi-yama, 24 vii 1979 (A. Seino); *Shimo-agata* - 1 ♀, Kashi - Shiradake, 22 vii 1978 (K. Katsura), 1 ex, Izuhara, 11 viii 1978 (K. Haruyama), 2 ♂ ♂ 2 ♀ ♀, Tsutsu, 22-23 viii 1979 (I. Hiura).

Distribution. Tsushima Is. (Kami-agata; Shimo-agata).

Taxonomic notes. I have examined one female specimen collected in Hakozaiki, Fukuoka-shi, Kyūshū (19 vii 1959, Y. Murakami leg.; parasitized by a female *Pseudoxenos*), with a color pattern very similar to the present subspecies. In this specimen the mandibles are much paler in color, and the basal marking on the clypeus is very small. This wasp may have been introduced from Tsushima to Kyūshū as suggested by Ishikawa (1970).

Yasumatsu (1935a) mentioned that on the Tsushima islands there occurs also the typical form of *A. flavopunctatum* with a yellow fascia on two basal tergites of gaster each. I have not examined such specimens from Tsushima. The form mentioned by Yasumatsu seems most probably *A. melanopterum*, which is sympatric with *A. flavomarginatum tsushimarum*.

According to Ishikawa (1970) the Korean population of this species belongs to *A. f. micado*, which is widely distributed in the Japanese mainlands, but, in my view, it is a distinct subspecies closely related to the nominate subspecies occurring in China (Yamane, 1981).

Anterhynchium flavomarginatum procella Sk. Yamane
(Figs. 132, 141, 148)

Anterhynchium flavomarginatum procella: Yamane and Tano, 1983, Mem. Kagoshima Univ. Res. Center 5. Pac. 4: 131, figs. 20, 29 (♀ ♂)(type loc.: Kuro-shima, Osumi Is.).

Diagnosis. This subspecies is characterized by the following combination of character states. Black clypeal markings much reduced (♀); gena often with a lower yellow (or reddish) spot or line in addition to the upper one (♀); mesoscutum with a yellow stripe on each side along the whole length of the base of tegula (usually in ♀, sometimes in ♂); propodeum with yellow markings on the dorsolateral face (♀ ♂); yellow apical band on gastral tergite 1 narrow, laterally narrowed (♀ ♂); gastral tergites 3-5 usually with yellow apical bands which are sometimes replaced with reddish brown (♀ ♂); last tergite and sternite black (♀); antennal pedicel above often tinged with reddish brown (♂).

Material examined. N. Ryukyus: *Take-shima* - 28 ♀ ♀, 29-30 viii 1983 (KT); *Iō-jima* - 5 ♂ ♂ 2 ♀ ♀, 1-3 vi 1982 (SKY), 3 ♂ ♂, 7 viii 1982 (KT); *Kuro-shima* - 36 ♂ ♂ 32 ♀ ♀ (incl. holotype and paratypes), Ōsato, 30 viii - 5 ix 1981 (SKY); *Ie-jima* - 1 ♀, 6-9 x 1981 (SKY); *Mukai-jima* - 1 ♀, 9 x 1983 (M. Ōhara).

Distribution. Mi-shima Is. (Take-shima; Iō-jima; Kuro-shima); Uji Is. (Ie-jima; Mukai-jima).

Taxonomic notes. This form is closely allied to the subsp. *micado*. The lower genal spot (line) in the female is peculiar to this form, but is not seen in all the specimens. The gastral tergite 3 almost always possesses a yellow apical band (sometimes interrupted medially), but this band is also seen in *micado* though rarely. Many specimens collected on Yakushima are intermediates between these two forms as discussed above. Although one male and one female specimen collected on August 4 1916 from Tane-ga-shima are rather *procella*-typed (see Yamane & Tano, 1983), recently collected specimens all belong to the *micado* type (also see Ogata & Nagase, 1987).

The following specimens from the Ogasawara Is. are more or less *procella*-typed. All

of them have the gastral tergite 3 with a rather distinct apical band that is yellowish at least partly. One female from Chichi-jima has a trace of reddish lower genal line on each side. It is not known whether the Ogasawara population of this species is native or has recently been introduced.

Ogasawara (Bonin) Is.: *Chichi-jima* - 1 ♂, 1 ♀, 16-17 viii 1972 (YH), 2 ♀, Futago, 9 viii 1983 (TN); *Haha-jima* - 1 ♂, Kitakoo, 11 viii 1983 (TN), 1 ♀, Okikoo, 12 viii 1983 (TN).

Biology. Parasite: *Pseudoxenos iwatai* (Kifune & Yamane, 1985).

Anterhynchium flavomarginatum insulicola Sk. Yamane

(Figs. 131, 140, 148)

Anterhynchium flavomarginatum insulicola: Yamane and Tano, 1983, Mem. Kagoshima Univ. Rec. Center S. Pac. 4: 130, figs. 19, 28 (♀ ♂) (type loc.: Kuchi-no-shima, Tokara Is.).

Diagnosis. Similar to the subsp. *amamense* from Amami-ōshima and Okinoerabu-jima. Blackish and brownish markings on clypeus rather developed (♀). Antennal flagellum below blackish (♀); antennal pedicel above black (♂). Apical bands on gastral tergites 1-5 (6) usually orange yellow, rarely replaced with reddish brown (♀ ♂); the band on tergite 1 relatively narrow, not distinctly widened laterally (♀ ♂); last tergite and sternite ferruginous (♀). Mid and/or hind coxae wholly black (♂). In the population of Suwanose-jima, yellow propodeal markings well developed.

Material examined. N. Ryukyus: *Kuchi-no-shima* - 4 ♂ ♂ 3 ♀ ♀, 28 vii - 1 viii 1981 (KT), 39 ♂ ♂ 8 ♀ ♀ (incl. holotype and paratypes), 24-27 vi 1982 (KT); *Naka-no-shima* - 1 ♀, 21 viii 1943, 1 ♂ 8 ♀ ♀, Satomura, 13-19 vii 1982 (Y. Takai), 2 ♀ ♀, Funakura, 14 vii 1982 (Y. Takai); *Suwanose-jima* - 8 ♂ ♂ 9 ♀ ♀, 30 vii - 1 viii 1985 (SI).

Distribution. Tokara Is. (Kuchi-no-shima; Naka-no-shima; Suwanose-jima).

Biology. Parasite: *Pseudoxenos iwatai* (Kifune & Yamane, 1985).

Anterhynchium flavomarginatum sulphreum Sk. Yamane

(Figs. 130, 139, 148)

Anterhynchium flavomarginatum sulphreum: Yamane and Tano, 1983, Mem. Kagoshima Univ. Rec. Center S. Pac. 4: 129-130, figs. 18, 27 (♀ ♂) (type loc.: Akuseki-jima, Tokara Is.).

Diagnosis. This subspecies is unique in its sulphur yellow body markings, especially on head and thorax (apical bands on gastral tergites often slightly tinged with orange). The following character states are also useful in separating it from the other forms. Black clypeal markings moderately developed (♀); frons sometimes with a supraclypeal yellow spot (♂); antennal flagellum below often ferruginous (♀); yellow markings on scutellum, metanotum and dorsal face of propodeum well developed (♀ ♂); gastral tergites 1 and 2 with apical bands distinctly widened laterally (that on tergite 1 often with lateral prongs anteriorly) (♀ ♂); apical bands on tergites 3-5(6) usually not replaced with brown (♀ ♂).

Material examined. N. Ryukyus: *Akuseki-jima* - 12 ♂ ♂ 8 ♀ ♀ (incl. holotype and paratypes), 7-10 viii 1981 (KT), 3 ♀ ♀, 25 vii 1982 (M. Ōhara); 1 ♂ 5 ♀ ♀, 3-8 vii 1984 (KT), 6 ♂ ♂, 2 viii 1985 (SI), 7 ♀ ♀, 18-19 viii 1987 (T. Moriyama).

C. Ryukyus: *Takara-jima* - 1 ♀, 29 vii 1986 (SI).

Distribution. Tokara Is. (Akuseki-jima; Takara-jima).

Biology. Parasite: *Pseudoxenos iwatai* (Kifune & Yamane, 1985).

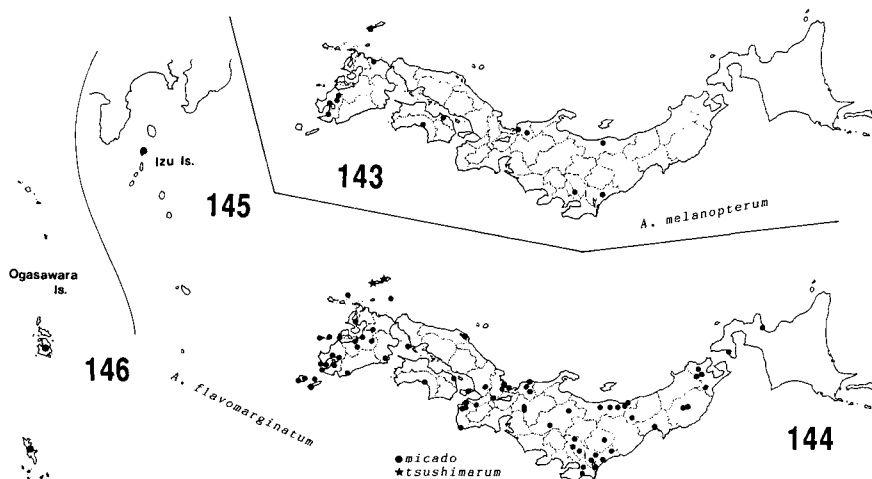

Figs. 143-146. Distribution of *Anterhynchium melanopterum* (143) and *A. flavomarginatum* (144-146; two subspecies) on the Japanese mainlands, Izu Islands and Ogasawara Islands.

Anterhynchium flavomarginatum amamense Tano
(Figs. 129, 136-138, 148)

Anterhynchium flavomarginatum amamense: Yamane and Tano, 1983, Mem. Kagoshima Univ. Rec. Center S. Pac. 4: 128-129, figs. 17, 24-26 (♀ ♂)(type loc.: Amami-ōshima).

Diagnosis. Female. Body markings are in pattern similar to those of the subspecies *hanedai*, but much paler in color. Black (brown) clypeal markings generally developed, but variable in size and shape. Antennal flagellum above entirely blackish, rarely tinged with reddish brown, but sometimes brownish below. Mesopleural spots never lost. Yellow markings on scutellum and metanotum rather developed. Propodeal spots always present, sometimes much developed. Yellow apical band on tergite 1 sometimes slightly widened laterally; that on tergite 2 usually distinctly widened laterally; last tergite and sternite usually blackish, at least partly. Yellow bands on tergites 3-5 very often replaced with reddish or dark brown. Legs ferruginous; femora usually blackish basally.

Male. Body markings paler than in the female. Similar to the male of the subspecies *hanedai*, but differs in the following points: body markings paler (yellow; only rarely orangish), antennal flagellum blackish (segments 7-9 below and last two segments wholly ferruginous), propodeum almost always with yellow spots, yellow band on tergite 1 much wider and often with anterior prongs on each side, apical bands on tergites 3-6 very often reduced or replaced with brown.

Material examined. C. Ryukyus: *Amami-ōshima* - 14 ♂♂ 4 ♀♀, Shimmura, 16 vii - 1 viii 1967 (TM), 1 ♂ 1 ♀, Gusuku, 21 vii 1967 (TM); 1 ♂, Santarō Pass, 23 vii 1967 (TM), 2 ♀♀, Kasari, 17-21 vii 1967 (TM), 1 ♀, Sato, 14 vii 1967 (TM), 1 ♀, Asani, 13 vii 1967 (TM), 1 ♀, Tomori, 16 vii 1967 (TM), 1 ♀, Uken, 28 vii 1972 (TN) (holotype), 1 ♂, Yuwan, 27 vii 1972 (TN), 1 ♀, Naze, 27 vii 1972 (TN), 1 ♂, Yuwan, 6 vii 1980 (H. Nagase), 1 ♂, Eboshi-dake, 6 vii 1980 (H. Nagase), 1 ♂ 4 ♀♀, Naze, 10-18 vii 1981 (YH), 1 ♂ 2 ♀♀, Kasari, 7 vii 1981 (YH), 1 ♂, Setouchi, 16 vii 1981 (YH), 1 ♀, Sumiyō, 13 vi 1981 (YH), 2 ♂♂, Akaogi, 30 vi 1984 (M. Ōhara), 1 ♂, Naze, 20 vi 1987 (SKY), 1 ♂, same loc., 10 vii 1987 (AN), 3 ♂♂, Sumiyō, 22 vi 1987 (SKY), 1 ♂ 1 ♀, Koniya,

22 vi 1987 (SKY), 1 ♀, Setouchi, 23 vi 1987 (M. Tatsuno), 3 ♀ ♀, Nishinakama, 25 vi 1987 (SKY), 1 ♂1 ♀, Naze, 14 vii 1988 (AN), 1 ♀, Nishinakama, 15 vii 1988 (AN); *Kakeroma-jima* - 2 ♀ ♀, 23-24 ix 1984 (AN); *Yoro-shima* - 2 ♂ ♂2 ♀ ♀, 13 viii 1987 (M. Tatsuno); *Tokuno-shima* - 2 ♂ ♂3 ♀ ♀, Kametoku, 13 vii 1984 (SKY); *Okinoerabu-jima* - 1 ♂, Tokutoki, 4 viii 1972 (TN), 1 ♀, Uchigusuku, 3 viii 1972 (TN), 2 ♀ ♀, China, 19 v 1981 (KT, Kukidome & Koya), 1 ♂1 ♀, Shinjō - Oyama, 15-16 vii 1981 (Y. Takai), 1 ♂2 ♀ ♀, 17-18 vii 1984 (M. Maegata).

Distribution. Amami Is. (Amami-ōshima; Kakeroma-jima; Yoro-shima; Tokuno-shima; Okinoerabu-jima). Kikai-jima seems to lack this species.

Taxonomic notes. The color pattern of the specimens from Okinoerabu-jima is rather variable. Although most of them fall into the range of variation seen on Amami-ōshima, the two females from China and the male from Shinjō - Oyama agree well with the subsp. *micado* in many details.

Biology. Parasite: *Pseudoxenos iwatai* from Amami-ōshima and Tokuno-shima.

Population of *Anterhynchium flavomarginatum* from Yoron-tō

Yoron-tō is a small flat island situated between Okinoerabu-jima and Okinawa-jima. All the specimens examined from this island, collected between 1983 and 1986, cannot be separated from *A. f. micado* occurring in the Japanese mainlands. Yellow apical bands are restricted to gastral tergites 1 and 2. Tergite 3 rarely possesses a rufous band, but usually tergites 3-6(7) are wholly black. It is possible, therefore, that the individuals from Yoron-tō and some from Okinoerabu-jima are descendants of immigrants from Kyūshū (subsp. *micado*), which invaded through human activities (Yamane & Tano, 1983).

Material examined. 1 ♂1 ♀, Chabana, 6 viii 1972 (TN), 1 ♀, 22 v 1983 (E. Matsui), 1 ♀, Gusuku, 22 v 1983 (M. Ōhara), 4 ♂ ♂9 ♀ ♀, 4-6 vi 1985 (SKY), 6 ♂ ♂5 ♀ ♀, 24-28 v 1986 (SKY).

Biology. In early June, 1985, a female wasp was observed nesting in a horizontal tunnel in a wooden pillar of a cabin in Akasaki.

Parasite: *Pseudoxenos iwatai* (new record for this island).

Anterhynchium flavomarginatum hanedai Tano

(Figs. 127, 128, 135, 148)

Anterhynchium flavomarginatum hanedai: Yamane and Tano, 1983, Mem. Kagoshima Univ. Rec. Center S. Pac. 4: 128, figs. 16, 23 (♀ ♂) (type loc.: Okinawa-jima); Giordani Soika, 1986, Boll. Mus. Civ. St. Nat. Venez. 35: 73.

Anterhynchium flavomarginatum luctuosum Giordani Soika, 1986, Boll. Mus. Civ. St. Nat. Venez. 35: 74 (♀) (type loc.: Sezoko-jima, Okinawa Is.). *Syn. nov.*

Rhynchium mandarineum Saussure: Matsumura and Uchida, 1926, Ins. Matsum. 1: 37-38.

Anterhynchium flavomarginatum umenoi: Yamane, 1981, Trans. Shikoku Entomol. Soc. 15: 224-225 (in key, part).

Japanese name: Okinawa-futaobi-dorobachi.

Diagnosis. Female. Body markings yellow, orange yellow and brown. Clypeus yellow, with lateral black or brown markings which are variable in size and shape. Frontal spot yellow, tinged with brown. Upper genal stripe very small and orange yellow. Depression for cephalic foveae on vertex with dense reddish brown pubescence. Antennal scape brownish above, yellowish below; flagellum blackish brown to reddish brown even on the upper face. Horizontal face of pronotum yellow (sometimes orangish or ferruginous); its lower and posterior portions black. Mesopleural spot yellow to

ferruginous, often lost. Scutellum and metanotum with orangish or ferruginous markings which are variable in size (often reduced). Propodeum always without yellowish markings. Apical bands on gastral tergites 1-5 usually dark orange yellow (those on tergites 3-5 rarely ferruginous). Last tergite light brown to ferruginous. Sternite 2 with an orange yellow apical band which is widely interrupted medially; subsequent sternites often with dark ferruginous, narrow, apical bands; last sternite ferruginous. Legs almost entirely ferruginous, but coxae, and sometimes trochanters and femora basally blackish; without yellow spots.

Male. Similar to the female in color pattern, but body markings paler. Antennal scape brown or blackish above, yellow below; flagellum ferruginous (sometimes much darker above); hook slightly yellowish. Propodeum sometimes with yellow spots. Orange yellow apical band on tergite 1 sometimes widened laterally, rarely with lateral prongs anteriorly; last tergite usually blackish. All the apical bands on tergites yellowish (not ferruginous). Sternites 2-6 with yellow or orange apical bands (often interrupted medially). Legs light brown to ferruginous, extensively marked with yellow.

Material examined. C. Ryukyus: *Okinawa-jima* - 1 ♂ 1 ♀, "Okinawa" (S. Sakaguchi), 1 ♂, "Okinawa", viii 1905 (Kuroiwa), 1 ♀, Shuri, 11 vii 1968 (S. Hashimoto); 1 ♂, Naha, 9 viii 1972 (TN), 4 ♂ 1 ♀, Nakagusuku, 3 x 1977 (SY), 1 ♂, Ogumi-son, 26 viii 1979 (H. Nagase), 1 ♂, Kunigami, 3-4 viii 1980 (KB), 1 ♂, Hyakuna, 1 vii 1981 (AN), 2 ♂ 1 ♀, Yona, 3 vii 1981 (AN), 2 ♂ 1 ♀, Hentona, 4 vii 1981 (AN), 1 ♀, Oku, 5 vii 1981 (AN), 12 ♂ 1 ♀ 5 ♀ ♀ (incl. holotype), Tôbaru, Kunigami, 3-9 vii 1982 (YH), 3 ♀ ♀, Yabu, Nago, 30 vi 1982 (YH), 1 ♀, Nagojôshi, 29 vi 1982 (YH), 4 ♂ 1 ♀, Okuma, Kunigami, 6-7 vii 1982 (YH), 1 ♂, Beshi, Motobu, 1 vii 1982 (YH), 1 ♂ 1 ♀, Yona, 2 vi 1983 (AN), 17 ♂ 1 ♀ 3 ♀ ♀, Hentona, 1-6 vi 1983 (AN), 1 ♂, Yona, 18 vii 1984 (SKY); *Sezoko-jima* - 3 ♀ ♀, 28 v - 1 vi 1982 (Y. Ikimori & Y. Ôhira); *Hamahiga-jima* - , 1 ♀, 22 x 1988 (Y. Kusui).

Distribution. Okinawa Is. (Okinawa-jima; Sezoko-jima; Hamahiga-jima; Kume-jima).

Taxonomic notes. This subspecies is characterized by the ferruginous flagellum (especially of the female), and the darkest body markings in the female among the Ryûkyû forms. However, there are a few specimens with lighter body markings and they are indistinguishable from the subsp. *amamense*. Tano (1987) mentioned that female specimens from Kume-jima often had a brownish marking on vertex posteriorly, and that in the male markings on scutellum and metanotum tended to be much reduced.

Biology. Parasite: *Pseudoxenos iwatai* from Okinawa-jima and Sezoko-jima (Maeta, 1980; Kifune & Yamane, 1985).

Anterhynchium flavomarginatum umenoi (Yasumatsu)

(Figs. 126, 134, 148)

Rhynchium umenoi Yasumatsu, 1933, Annot. Zool. Jpn. 14: 262-265, 271, fig. 3 (♀)(type loc.: Ishigaki-jima, Yaeyama Is.).

Anterhynchium flavomarginatum umenoi: Vecht, 1963, Zool. Verh. 60: 81; Yamane, 1981, Trans. Shikoku Entomol. Soc. 15: 224-225 (in key); Yamane and Tano, 1983, Mem. Kagoshima Univ. Res. Center S. Pac. 4: 126-128, figs. 14, 22.

Japanese name: Yaeyama-futaobi-dorobachi.

Diagnosis. Female. The specimens examined well agree with the original description by Yasumatsu (1933). Body markings are yellow, but sometimes orangish; the type specimen which was said to have orange yellow markings may represent an extreme variation. Pronotum is black in its posterior portion of the horizontal face. Mesoscutum sometimes possesses very faint median stripes. Propodeum almost always lacks yellow

markings.

Male. Yellow markings rich; the markings paler than in the female, and only rarely orangish. Mandible with a yellow stripe. Supraclypeal spot present, often connected with frontal mark. Antennal scape entirely yellow; pedicel brownish; flagellar segment 1 below and some of the terminal segments below ferruginous. Gena yellow except for posterior portion. Tegula yellow except for central ferruginous part. Apical bands on gastral tergites 1-6 rather wide (last tergite entirely brownish but sometimes apically yellowish); apical bands on sternites 2-6 narrow and yellow (last sternite light brown). Tergites 5 and 6, and sternites 5 and 6 sometimes brownish basally. Legs light brown, with yellow markings on femora and tibiae.

Material examined. S. Ryukyus: *Miyako-jima* - 1 ♀, Hirara, 28 vi 1988 (SKY); *Ishigaki-jima* - 2 ♂♂, Nagurahama, 31 vii 1969 (TT), 2 ♂♂, Takeda, 13 viii 1972 (TN), 1 ♀, Omoto-dake, 30 viii 1978 (K. Hara), 1 ♀, Yonehara, 28 viii 1978 (TN), 1 ♀, Banna-dake, 29 viii 1978 (TN), 3 ♂♂, Kabira, 22 vii 1987 (SKY), 1 ♂1 ♀ Shiraho, 26 vii 1987 (SKY), 1 ♀, Kabira, 20 v 1988 (K. Nakamine), 1 ♂, Omoto-dake, 11 vi 1988 (K. Nakamine), 7 ♂♂3 ♀♀, same loc., 3-8 vii 1988 (K. Nakamine), 5 ♂♂2 ♀♀, Banna-dake, 3-8 vii 1988 (K. Nakamine), 10 ♂♂2 ♀♀, same loc., 4 vii 1988 (SKY), 1 ♂, same loc., 3 x 1988 (SI); *Takekomi-jima* - 1 ♂, 25 vii 1987 (SKY), 1 ♂, 8 vii 1988 (K. Nakamine); *Kuro-shima* - 8 ♂♂1 ♀, 23-24 vii 1987 (SKY); *Kohama-jima* - 3 ♂♂1 ♀, 25 vii 1987 (SKY); *Iriomote-jima* - 6 ♂♂4 ♀♀, Funaura, 9 x 1977 (SY), 1 ♀, Hoshidate, 8 x 1977 (SY), 5 ♂♂6 ♀♀, Komi, 11-24 viii 1978 (TN), 2 ♀♀, Kanebire-taki, 23 viii 1978 (TN), 1 ♀, Funaura, 22 viii 1978 (TN), 1 ♀, Ôhara, 19 viii 1978 (TN), 1 ♂2 ♀♀, same loc., 20-24 v 1981 (AN), 2 ♂♂1 ♀, Toyohara, 20 v 1981 (AN), 1 ♂, Sonai, 20 iv 1981 (T. Fujisawa), 1 ♀, Ôhara, 2 v 1982 (AN), 1 ♂, Ôtomi, 29 vii 1983 (AN), 1 ♀, Ôhara, 29 vii

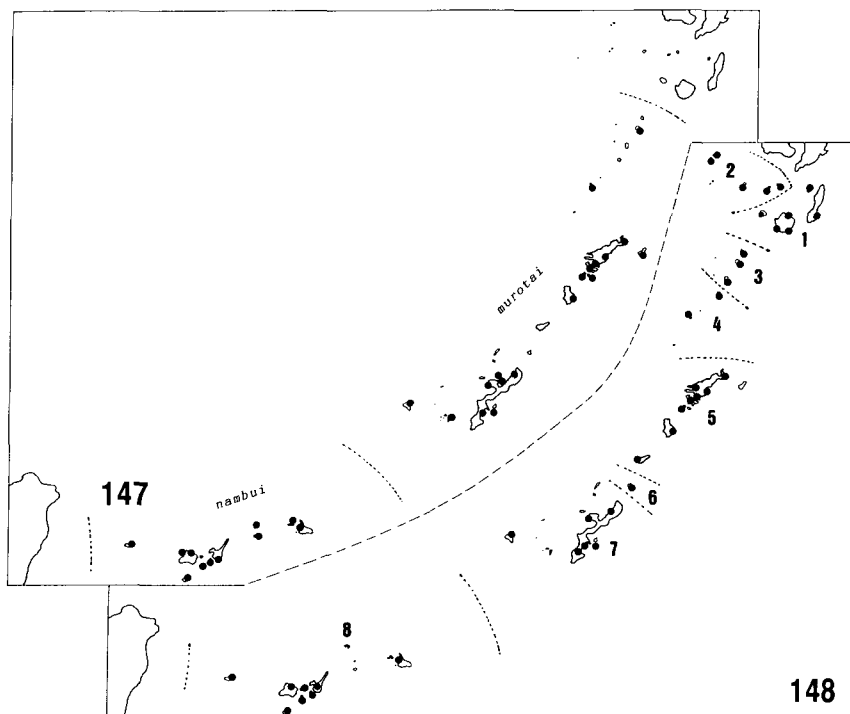

Figs. 147, 148. Distribution of *Rhynchium quinquecinctum* (147; two subspecies) and *Antherhynchium flavomarginatum* (148) in the Ryukyus. 1, ssp. *micado*; 2, ssp. *procella*; 3, ssp. *insulicola*; 4, ssp. *sulphreum*; 5, ssp. *amamense*; 6, population of Yoron-tô; 7, ssp. *hanedai*; 8, ssp. *umenoi*.

1983 (AN), 2 ♂♂, Toyohara, 30 vii 1983 (AN), 4 ♂♂3 ♀♀, Komi, 29-31 vii 1983 (AN), 2 ♂♂1 ♀, Ôtomi, 25 vii - 3 viii 1985 (AN), 3 ♀♀, Amitori, 30 vii - 1 viii 1985 (AN), 1 ♀, Toyohara, 26 vii 1985 (AN), 2 ♂♂1 ♀, same loc., 11 x 1987 (AN), 2 ♂♂, Ôhara, 13 x 1987 (AN), 1 ♂♂2 ♀♀, Komi, 3 vii 1988 (SKY), 1 ♂♂, Uehara, 2 vii 1988 (SKY), 1 ♀, Mihara, 4 xii 1988 (SKY); *Hateruma-jima* - 3 ♂♂♂, 1 vii 1988 (SKY); 1 ♂♂1 ♀, Naishi, 2 x 1988 (SI).

Distribution. Miyako Is. (Miyako-jima); Yaeyama Is. (Ishigaki-jima; Taketomi-jima; Kuro-shima; Kohama-jima; Iriomote-jima; Hatoma-jima; Hateruma-jima; Yonaguni-jima after Tano, 1985).

Taxonomic notes. The male of this form is readily separated from that of any other form of this species in Japan by the entirely yellow scape, well developed yellow genal band, and the yellow stripe on mandible. We could not find any remarkable difference in color pattern among the populations of the islands. However, the female specimen (parasitized by a female *Pseudoxenos*) from Miyako-jima is very peculiar in having antennae nearly wholly orange yellow, and the depression (in which lie the cephalic foveae) on vertex orange yellow. It is uncertain whether this color pattern is normal in the population of the island. Vecht (1963) mentioned that the Taiwanese form well agreed with Yasumatsu's description of this form, but in fact these two are not alike at all.

Biology. On December 4 1988, on Iriomote-jima, a female wasp was observed nesting in a bamboo tube that was used as part of a chair at a bus stop.

Parasite: *Pseudoxenos iwatai* from Miyako-jima (new record), Ishigaki-jima (new record), and Iriomote-jima (Kifune & Yamane, 1985).

Anterhynchium melanopterum Sk. Yamane
(Figs. 121, 123, 125, 143)

Anterhynchium melanopterum Yamane, 1981, Trans. Shikoku Entomol. Soc. 15: 221, 222, figs. 1, 3 (♀♂) (type loc.: Kagoshima, Kyûshû).

Japanese name: Haguro-futaobi-dorobachi.

Diagnosis. Female. Body length (h+th+t1+2): 12.5-16.0 mm. Head with strong and dense punctures that are somewhat reticulate. Hairy depression (with cephalic foveae) on the vertex obscure or almost invisible (the depression is distinct in *A. flavomarginatum*). Clypeus slightly wider than long, strongly punctate, only narrowly and shallowly emarginate at apex; apical teeth blunt. Keel between the antennae sharp. Hairs on frons and ocellar region not very uniform in length and shape. Thorax strongly and densely punctate or reticulate, with weak transverse striae on the anterolateral part of pronotum; anterior fourth of mesepisternum and lower half of dorsal metapleuron almost impunctate. Posterior edge of metanotum spinose. Propodeum with the posterior face distinctly striate; upper projections distinct and sharp behind the metanotum; posterolateral angles developed. Below metanotum a large triangular impunctate area, between the lateral halves of the posterior face of propodeum. Lateral sides of propodeum transversely striate, partly reticulate. Gastral tergites 1 and 2 finely and somewhat densely punctate; punctures on tergites 3-5 slightly larger than those on the preceding ones, especially near the apex. Narrow basal part of sternite 1 finely striate; posterior triangular part with rather coarse striation. Sternites 2-5 punctate as in tergites; last sternite nearly impunctate.

Black, with orange yellow markings. Orange yellow are: a large basal triangular

marking on clypeus, a transverse spot between antennae, scape below, a small spot behind each eye, a transverse band on pronotum anteriorly (medially interrupted), apical bands on gastral tergites 1 and 2. Tarsi of all legs somewhat brownish. Wings infuscated, darker than in *A. flavomarginatum micado* (blackish vs. brownish).

Male. Body length (h+th+t1+2): 9.5-10.5 mm. Similar to the female. Clypeus entirely yellow, longer than wide; clypeal ratio (a/b; Fig. 121): ca. 2.9 (in *flavomarginatum* 3.13-3.44); apex more widely emarginate than in the female. Hairs on head and thorax disheveled, long; those on clypeus much shorter. Aedeagus of male genitalia with a weak subapical constriction; shaft thicker than in *A. flavomarginatum*.

Material examined. Honshū: Niigata-ken - 1 ♀, Nagaoka, 9 vii 1976 (SKY); Tōkyō-to - 1 ♀, Akabane, 23 ix 1937 (N. Kumazawa).

Shikoku: Kōchi-ken - 1 ♀, Kōchi, 13 ix 1956 (J. Minamikawa), 2 ♂♂, Saigyōji, 2 viii 1959 (J. Minamikawa), 1 ♀, Godaisan, Kōchi-shi, 1 x 1975 (SI); Kagawa-ken - 1 ♂, Kotohira, 22 viii 1959 (J. Minamikawa).

Kyūshū: Fukuoka-ken - 1 ♀, Koshii, 29 ix 1959 (YM)(gaster lost), 1 ♀, Hakozaki, 7 vii 1959 (Y. Miyatake) (gaster lost); Miyazaki-ken - 1 ♀, Omata, 15 vii 1954 (K. Nohara); Kagoshima-ken - 1 ♀ (holotype), Kagoshima-shi, 14 ix 1980 (H. Nagase).

Tsushima Is. (Nagasaki-ken): 1 ♂, Sumo, 23 vii 1978 (K. Tani); Shimo-agata - 1 ♀, Tatsura-yama, 15 x 1979 (T. Kumata), 1 ♂, Izuhara, 27 vii 1986 (K. Nakamine).

Distribution. Honshū; Shikoku; Kyūshū; Tsushima Is.

Taxonomic notes. This species is closely related to *A. flavomarginatum*, but distinguished from the latter by the wider clypeus (♀ ♂), obscure depression for cephalic foveae on vertex (♀), and the thicker aedeagal shaft (♂). In color pattern this species is quite similar to *Orancistrocerus drewseni drewseni*, while easily distinguished from *A. flavomarginatum micado*, the latter two forms being widely sympatric with this species on the mainlands of Japan. Another unnamed subspecies of *A. melanopterum* occurs in northeastern China (I have examined some specimens deposited in the Zoological Museum, Leiden). One male specimen from Tsushima has an exceptionally short clypeus, condition being comparable to that in *A. flavopunctatum* of the continental Asia. I tentatively consider this condition to be included within the range of variation in *melanopterum*.

Biology. Nothing is known about the nesting behavior of this species.

Parasite: *Pseudoxenos iwatai* (Strepsiptera, Stylopidae) (new host record) from Akabane, Tōkyō.

Genus *Okinawepipona* Sk. Yamane

Okinawepipona Yamane, 1987, Mem. Kagoshima Univ. Res. Center S. Pac. 8: 52-53 (type species: *Anterhynchium (Epiodynerus) kogimai* Giordani Soika, monotypic).

Japanese name: Okinawa-dorobachi Zoku.

Diagnosis. Clypeus moderately convex, as high as wide, narrowly emarginate at apex in both sexes. Male mandible not deeply emarginate on inner side. Maxillary palp 5-segmented; labial palp 3-segmented (Fig. 8). Scutellum flat; metanotum medially not concave. Tegula not extending beyond the apex of parategula (Fig. 150). Propodeum without lateral crest. Anterior vertical face of gastral tergite 1 almost impunctate, clearly separable from the posterior horizontal part, but not by a carina; laterally the tergite

divided by a sharp carina into upper and lower part. Gastral segment 1 slightly narrower than segment 2. Tergites 1-5 each with a dark apical spot medially where the integument is weakly impressed. Narrow basal part of sternite 1 irregularly striate posteriorly, not shining. Basal part of sternite 2 with 14-18 strong, longitudinal carinae (Fig. 152). Parastigma of fore wing short, less than half as long as the stigma.

This genus was first mentioned in the key to the Japanese genera of Eumenidae by Yamane (1982)(referred to as "Okinawa-dorobachi-zoku"). Although there are few autapomorphies, the genus is distinguished from the related genera by the characteristics mentioned above, especially by the reduced numbers of segments of maxillary and labial palpi and short parastigma. In the latter condition, this genus is similar to *Pararrhynchium* rather than to *Anterhynchium*. Thus Giordani Soika's (1986) assignment of his new species *kogimai* to the subgenus *Epiodynerus* of the genus *Anterhynchium* is not supported.

Okinawepipona kogimai (Giordani Soika)
(Figs. 8, 149-162, 182)

Anterhynchium (*Epiodynerus*) *kogimai* Giordani Soika, 1986, Boll. Mus. Civ. Stor. Nat. Venez. 35: 74-76 (♀ ♂)(type loc.: Sezoko-jima, Okinawa Is.).

Okinawepipona kogimai: Yamane, 1987, Mem. Kagoshima Univ. Res. Center S. Pac. 8: 53-54, figs. 1-4.
Japanese name: Okinawa-dorobachi.

Diagnosis. Female. Body length (h+th+t1+2): 11.0-12.5 mm. Fore wing length: 11.0-12.0 mm. Head subcircular, densely punctate. Supraclypeal area with a vertical carina between the antennal sockets; above the carina interantennal region with a narrow vertical groove. Occipital carina complete, but dorsally somewhat weak. Ocellar triangle flat; distance between the posterior ocelli slightly longer than or as long as the distance between posterior ocellus and eye. Depression for cephalic foveae not conspicuous. Gena moderately developed, in profile narrower than the eye. Mandible pointed at apex; apical part often heavily worn; inner edge with four round teeth. Thorax somewhat elongate, densely punctate. Pronotal carina almost complete, only slightly interrupted dorsally. Anterior vertical part of pronotum virtually without punctures. Posterior 1/3 of mesoscutum and whole scutellum nearly flat. Dorsal mesepisternum below impunctate. Punctuation sparse on metapleuron. Metanotum slightly convex. Propodeum rather developed; basal triangular area with a median groove, at the lower end of which a median carina starts; dorsolateral face of propodeum with rugose punctuation; posterior face with striae; lateral face above with punctures and below with weak striae. Punctuation on gastral tergites much weaker than on thorax and propodeum except on the dorsal face of tergite 1 where the punctures are larger and dense but shallower than on thorax. Punctuation on gastral sternites 2-6 still finer than on corresponding tergites. Hind coxa with a distinct carina, which is elevated to form a triangular process (Fig. 151).

Male. Body length (t+th+t1+2): 9.0-10.0 mm. Fore wing length: 9.0-10.5 mm. Similar to the female. Apical emargination of clypeus deeper than in the female. Antennal segments 12 and 13 very small (Fig. 149).

This species is peculiar to the Central Ryukyus (subspecies *nagasei* & *kogimai*) and Taiwan (subsp. *taiwana*) (Figs. 153-162). No information is available regarding the nesting biology of this species.

Okinawepipona kogimai nagasei Sk. Yamane
(Figs. 153, 154, 158, 159, 182)

Okinawepipona kogimai nagasei Yamane, 1987, Mem. Kagoshima Univ. Res. Center S. Pac. 8: 54-55, figs. 5, 6, 10, 11 (♂ ♀) (type loc.: Amami-ōshima).

Diagnosis. Female. Black with yellow and orange yellow markings as follows: clypeus wholly (with brownish lower rim), mandible except for apex and inner teeth, frontal marking which is connected by a narrow line to the yellow of clypeus, a vertical line below anterior ocellus, a stripe along inner edge of eye from the upper margin of clypeus to the top of eye, gena along outer edge of eye, antennal scape below, posterior horizontal portion of pronotum extensively, a large spot under wing base, tegula (with a central spot and margins brownish), a pair of short lines on mesoscutum, a line on mesoscutum along the inner edge of tegula, parategula, scutellum and metanotum largely, apical bands on gastral tergites 1-5 (widest on tergite 2 and very narrow on tergites 3-5), an apical band on gastral sternite 2. Scape above and pedicel brown; flagellum blackish brown above and orange below. Legs testaceous; all the coxae black; basal 1/3 of fore and mid femora, and ventral face of hind femur dark.

Male. In coloration very similar to the female, but yellow marking along inner edge of eye not reaching the top of eye. Frons without yellow line just below anterior ocellus. Genal band reduced to a short line. Gastral tergites 6 and 7 wholly black. Legs yellow.

Material examined. C. Ryukyus: *Takara-jima* - 1 ♀, 2-11 viii 1985 (M. Kawana); *Amami-ōshima* - 2 ♀ ♀, Nishinakama, 25-26 vi 1961 (K. Tsuneki); 2 ♀ ♀, Gusuku, 1 vii 1961 (K. Tsuneki); 1 ♀, Akaogi, 7 vii 1961 (K. Tsuneki); 1 ♀, Kachiura, 3 vii 1961 (K. Tsuneki); 1 ♀, Santarō Pass, 23 vii 1967 (TM); 1 ♀, Shimmura, 1 viii 1969 (TM); 1 ♂ (holotype), Kasari, 20 v 1979 (H. Nagase), 1 ♂ 1 ♀, Yuwan-dake, 20 vi 1983 (K. Nichō), 2 ♀ ♀, Sumiyō, 22 vi 1987 (SKY), 1 ♂, Shinokawa, 23 vi 1987 (SKY).

Distribution. Tokara Is. (*Takara-jima*); Amami Is. (*Amami-ōshima*).

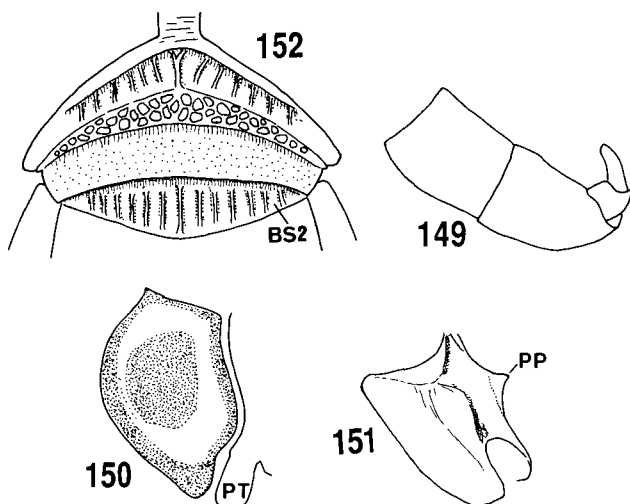

Figs. 149-152. *Okinawepipona kogimai* (after Yamane, 1987). 149, terminal segments of male antenna; 150, tegula and parategula (PT); 151, hind coxa, showing posterior process (PP); 152, gastral sternites 1 and 2 (BS2, basal part of sternite 2).

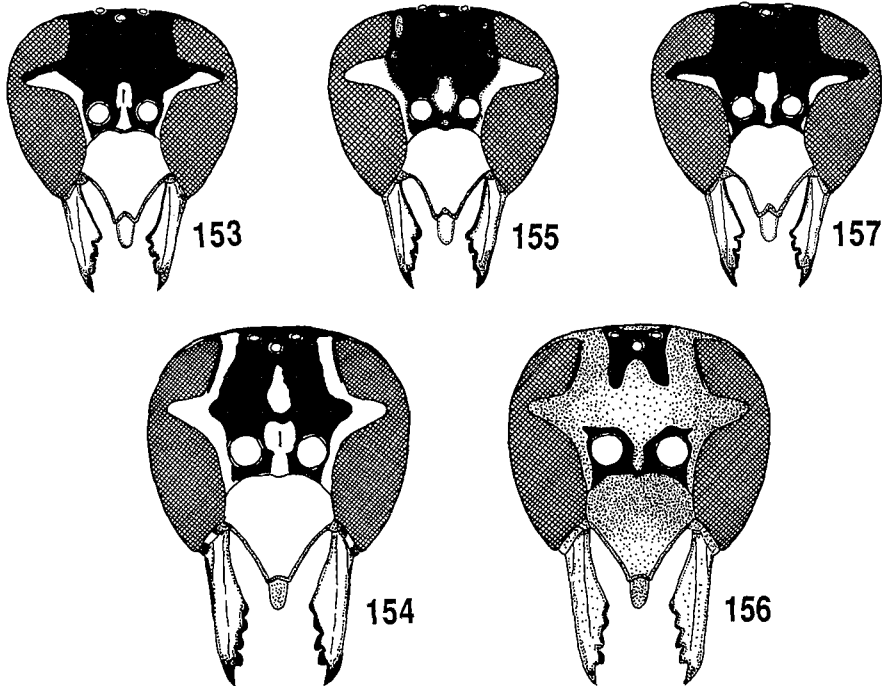

Figs. 153-157. Facial color pattern in the three subspecies of *Okinawepipona kogimai* (after Yamane, 1987). 153, subsp. *nagasei* ♂; 154, ditto ♀; 155, subsp. *kogimai* ♂; 156, ditto ♀; 157, subsp. *taiwana* ♂.

Okinawepipona kogimai kogimai (Giordani Soika)
(Figs. 155, 156, 160, 161, 182)

Okinawepipona kogimai kogimai: Yamane, 1987, Mem. Kagoshima Univ. Res. Center S. Pac. 8: 55-56, figs. 7, 8, 12, 13.

Diagnosis. Female. Similar to the preceding subspecies, but body markings much darker, especially on frons, vertex, thorax and gastral tergites 1 and 2. Head extensively orange or rufous; a narrow space around antennal sockets, a U-shaped area on vertex including ocellar region, and markings on gena posteriorly and temple black. Propodeum occasionally with reddish spots. Apical band on gastral tergite 2 wide; basal black area being less than 1/3 as wide as the total length of the tergite (in subsp. *nagasei* apical bands always less than half as wide as the length of the tergite). Fore and mid femora almost wholly testaceous.

Male. Orange and yellowish markings much less developed than in the female. Pattern of the body markings similar to that in the subsp. *nagasei* except that markings are much darker in this form.

Material examined. C. Ryukyus: *Okinawa-jima* - 1 ♀, Shuri, 6 vi 1970 (M. Kinjo); 1 ♂, 15 v 1973 (M. Kinjo); 1 ♂, Kudaken, 15 v 1973 (M. Kinjo); 1 ♀, Nago, 4-5 v 1976 (H. Takizawa); 1 ♀, Motobu, 29 v 1981 (K. Kojima); 2 ♀ ♀, Yona, 17 vii 1984 (SKY); *Sezoko-jima* - 1 ♀, 9 v 1982 (J. Kojima)(paratype), 1 ♀, 28 v - 1 vi 1982 (Y. Ikimori & Y. Ohira).

Distribution. Okinawa Is. (Okinawa-jima; Sezoko-jima).

Genus *Pararrhynchium* Saussure

Pararrhynchium Saussure, 1855, Et. Fam. Vesp. vol. 3, p. 173 (division of genus *Rhynchium* Spinola)(type species: *Rhynchium ornatum* Smith, 1852, monotypic); Dalla Torre, 1894, Cat. Hym. vol. 9, p. 42 (*Parrhynchium* !); Vecht, 1963, Zool. Verh. 60: 58 (in key), 94; Vecht and Fischer, 1972, Hym. Cat. pars 8, p. 107; Carpenter, 1986, Psyche 93: 79.

Prorrhynchium Saussure, 1855, Et. Fam. Vesp. vol. 3, p. 174 (division of genus *Rhynchium* Spinola)(type species: *Rhynchium smithii* Saussure, 1855, monotypic).

Japanese names: Kabafu-dorobachi Zoku (Kabafusuji-dorobachi Zoku).

This genus is characterized by the following characteristics (Vecht, 1963). Labrum of female with very short hairs, at most with a few longer hairs at its anterior margin. Apical margin of clypeus wide, more or less emarginate. Concavity of propodeum margined by a crest, which is incised dorsally in the middle, and is separated from the metanotum by a short horizontal area (propodeal shelf). Gastral tergite 1 with a transverse ridge separating the anterior vertical face from the posterior horizontal part. Parastigma short, distinctly less than half as long as the stigma. Cubital cell 3 separated from the apex of the radial cell by a long distance, much more than half the width of the latter cell.

Recurrent vein 2 of fore wing attaches to the cubital vein at the point relatively close to intercubital vein 2, and in the Japanese population of *P. ornatum* the former is very close to the latter or these two are even directly connected. These conditions disagree with Vecht's view that in this genus the recurrent vein 2 is never very close to intercubital vein. The females of all the Japanese species have a long, medially flattened clypeus which is widely truncate and shallowly emarginate at apex. *P. oceanicum*, described below as a new species, is unusual in that both the epicnemial carina and propodeal shelf are completely lost and body sculpture is very superficial.

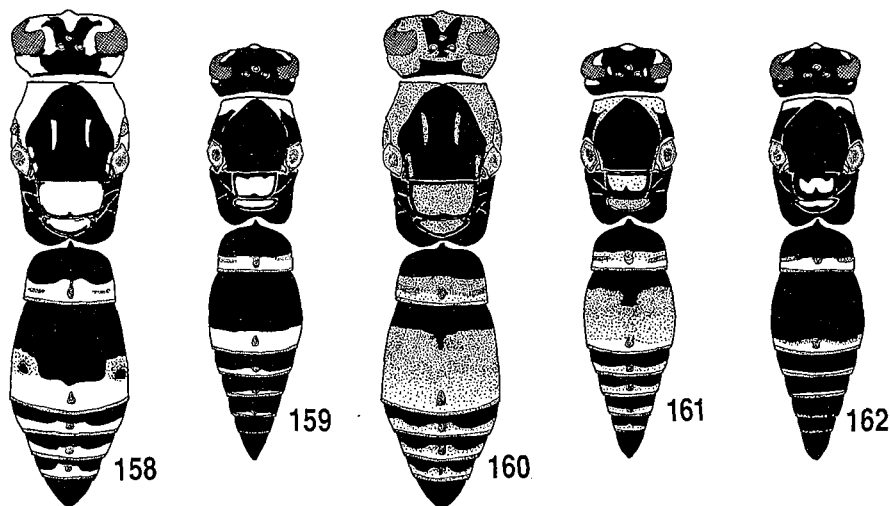

Figs. 158-162. Body color pattern in the three subspecies of *Okinawepipona kogimai* (after Yamane, 1987). 158, subsp. *nagasei* ♀; 159, ditto ♂; 160, subsp. *kogimai* ♀; 161, ditto ♂; 162, subsp. *taiwana* ♂.

Key to the Japanese species

1. Propodeum without shelf; crest undeveloped. Epicnemial carina absent. Male unknown. *P. oceanicum* sp. nov.
 - Propodeum with a distinct shelf between the crest and metanotum. Epicnemial carina present. 2
2. Body markings yellowish. Head and alitrunk extensively marked with yellow. Female clypeus with the apical margin lamellate. Occipital carina in profile somewhat strongly bent at 3/5 from the top of head. Metanotum without distinct longitudinal furrow. Basal lobe of aedeagus relatively thick, distinctly shorter than aedeagal apodeme; each lobe of ventral process of aedeagus not strongly curved. *P. ishigakiense* (Yasum.)
 - Body markings orange. Head and alitrunk almost wholly black or with a few markings. Apical margin of female clypeus not lamellate, black. Occipital carina in profile evenly arched so that the gena gradually narrowed below. Metanotum various. 3
3. Female clypeus above orange. Frontal spot present. Female antennal scape below orange. Flattened part of female clypeus less sharply defined, not shining, with sparse medium-sized punctures. Metanotum usually with a deep median furrow. Mesoscutum nearly as long as wide. Basal lobe of aedeagus slender, as long as or only slightly shorter than aedeagal apodeme; each lobe of the ventral process of aedeagus strongly curved. *P. ornatum ornatum* (Smith)
 - Female clypeus entirely black. Frontal spot absent or much reduced. Female antennal scape below ferruginous. Alitrunk entirely black. Gastral tergites 3-6 wholly black. Flattened part of clypeus well defined, shining, with sparse fine punctures. Median furrow of metanotum indistinct. Mesoscutum longer than wide (50:43). Male unknown. *P. tsunekii* Tano et Yam.

Pararrhynchium ishigakiense (Yasumatsu) (Figs. 163, 165, 168, 170, 173, 182)

Ancistrocerus ishigakiensis Yasumatsu, 1933, Annot. Zool. Jpn. 14: 260-262, 271, figs. 1, 2 (♀)(type loc.: Ishigaki-jima, Yaeyama Is.); 1935, Ibid. 15: 38, figs. 1B, C (♂).

Pararrhynchium ishigakiense: Yamane and Tano, 1983, Mem. Kagoshima Univ. Res. Center S. Pac. 4: 120, figs. 1, 3, 6, 9.

Japanese name: Ishigaki-kabafu-dorobachi.

Diagnosis. Female. Body length (h+th+t1+2): 11.5-12.0 mm. Fore wing length: 11.0-12.5 mm. Head nearly circular, strongly punctate. Cephalic foveae small, situated close to each other, the area being slightly elevated. Ocellar triangle flat. Gena, seen from above, slightly wider than eye. Interantennal keel distinct. Clypeus higher than wide, sparsely punctate, apically broadly truncate (emargination quite shallow); median flattened portion relatively well defined; apical margin lamellate (Fig. 165). Occipital carina in profile somewhat strongly bent at 3/5 from the top of head (Fig. 163). Pronotum very densely and strongly punctate, somewhat reticulate. Pretegular carina developed. Epicnemium with a row of large punctures along the anterior margin, with much smaller punctures near the sternopleural groove. Other parts of mesopleuron densely and strongly punctate. Mesoscutum strongly punctate, somewhat reticulate; prescutal grooves

not conspicuous. Scutellum punctate, with a narrow median groove; just in front of metanotum there is a wide transverse groove with many short carinae. Metanotum weakly punctate. Metapleuron and lateral side of propodeum punctate and often also striate; punctures much smaller than on propodeum. Dorsal face of propodeum strongly and densely punctate, somewhat reticulate; propodeal concavity much wider than high, dull, with obliquely running indistinct carinae; inferior median carina about half the height of concavity; superior carinae apically forming a pair of relatively sharp teeth behind metanotum (Fig. 170). Upper half of the anterior vertical face of gastral tergite 1 punctate, with a median longitudinal carina; transverse ridge not sharp. Gastral segment 1 distinctly narrower than segment 2. Gastral tergites finely punctate; tergite 2 lamellate apically; tergites 1-5 each with a preapical drop-shaped dark spot. Sternite 2 finely punctate; punctation on other sternites much weaker. Parastigma less than half the pterostigma.

Black, with the following parts yellow: clypeus wholly, a wide band along the inner margin of eye from clypeus beyond the upper margin of eye, a heart-shaped frontal mark, a rhombic marking above it, gena wholly, postgena, a triangle basal marking on mandible (other parts of mandible yellowish brown), antennal scape (pedicel and basal part of flagellar segment 1 orange), anterior vertical portion of pronotum above, dorsal part of pronotum largely, a U-shaped marking on mesoscutum, dorsal mesepisternum, a stripe on ventral mesepisternum (often lost in the populations of Iriomote-jima and Yonaguni-jima), tegula except for central and peripheral transparent parts, parategula (often wholly black), scutellum, metanotum, wide apical bands on tergites 1-5, a pair of large spots on tergite 2 which are laterally connected with the wide apical band, narrower apical bands on sternites 2-5. Segment 6 wholly yellow or ochereous, tinged with brown. All the legs extensively yellowish; mid and hind coxae and femora often brownish). Wings yellow-infumated.

Male. Body length (h+th+t1+2): 9.0-11.0 mm. Fore wing length: 7.5-9.5 mm. Very similar to the female in structure and coloration. Clypeus approximately as high as wide; apical emargination deeper than in the female; lateral angles sharp; median flattened area ill defined. Apex of antennal hook reaching the apical margin of segment 10 (Fig. 168). Area behind the ocelli less elevated and strongly punctate. Gena less developed, in profile much narrower than eye. Facial yellow markings much reduced, never connected with the yellow parts of inner orbits. Mesoscutal marking also much reduced, never forming a U.

Material examined. S. Ryukyus: *Ishigaki-jima* - 7 ♂♂ 2 ♀♀, *Ishigaki-shi*, 25 iii - 1 iv 1977 (J. Nakayama), 1 ♂ 1 ♀, same loc., 18-19 iv 1981 (T. Fujisawa), 1 ♀, *Banna-dake*, 4 vii 1988 (SKY); *Iriomote-jima* - 1 ♀, *Shirahama*, 18 viii 1971 (S. Yamauchi), 1 ♂, *Funaura*, 9 x 1977 (SY), 1 ♂ 4 ♀♀, *Ôtomi*, 15-19 v 1981 (AN), 1 ♂, *Toyohara*, 26 vii 1985 (AN); *Yonaguni-jima* - 1 ♂ 1 ♀, 24-25 iv 1988 (YM), 3 ♂♂ 2 ♀♀, *Sonai*, 5 vii 1988 (SKY).

Distribution. S. Ryukyus (*Ishigaki-jima*; *Iriomote-jima*; *Yonaguni-jima*).

Biology. No information is available.

Pararrhynchium ornatum ornatum (Smith)

(Figs. 118, 164, 167, 169, 172, 174, 182)

Rhynchium ornatum Smith, 1852, *Trans. Entomol. Soc. Lond.* (2)2: 36 (♀)(type loc.: Tein-tung, China); *Yano*, 1932, *Icon. Ins. Jpn.* p. 308, f. 598.

Odynerus ornatus: *Schulthess*, 1934, *Arb. Morph. Tax. Entomol.* 1: 70 (in key); *Yasumatsu*, 1938, *Ins. Jpn. Ill. Icon.* p. 359, f. 628-1 (subgenus *Ancistrocerus*).

Odynerus shinto Schulthess, 1908, Mitt. Schweiz. Entomol. Ges. 11: 286 (♀)(type loc.: Yokohama, Honshū).

Ancistrocerus ornatus: Yasumatsu, 1950, Icon. Ins. Jpn. 2nd Ed. p. 1457, f. 4204.

Pararrhynchium ornatum ornatum: Vecht, 1963, Zool. Verh. 60: 95; Yamane and Tano, 1983, Mem. Kagoshima Univ. Res. Center S. Pac. 4: 121-122, ff. 2, 5, 8, 10.

Pararrhynchium ornatum: Ishikawa, 1965, Icon. Ins. Jpn. Col. Nat. Ed. 3: 297, pl. 149, f. 2.

Japanese names: Nami-kabafu-dorobachi (kabafu-suji-dorobachi).

Diagnosis. Female. Body length (h+th+t1+2): 12.0-14.0 mm. Fore wing length: 11.0-12.0 mm. Head slightly wider than high, strongly punctate. Gena, seen from above, as wide as eye. Clypeus slightly higher than wide, relatively finely and sparsely punctate; median flattened portion ill defined (Fig. 167). Interantennal carina blunt. Cephalic foveae very small, situated in a shallow depression in a slightly elevated part which bears dense pubescence. Occipital carina not strongly bent so that gena gradually narrowed toward the mandibular base (Fig. 164). Anterior vertical face of pronotum shining, laterally with dense punctures and finely punctate near upper margin. Dorsal part of pronotum strongly punctate; pretegular carina developed. Mesoscutum densely and strongly punctate; median area with sparse punctation; prescutal furrows distinct. Scutellum strongly punctate, with a median longitudinal furrow, anteriorly with a transverse furrow which has 8-9 short carinae. Epicnemial carina complete; epicnemeium with dense punctures below, with a row of larger punctures along anterior margin. Mesepisternum and mesepimeron rugosely punctate; on dorsal mesepisternum spaces between punctures forming irregular carinae. Metanotum punctate, depressed posteriorly; anterior margin with a median notch. Metapleuron superficially striate, and relatively finely punctate. Propodeum with large punctures on dorsal and lateral portions; spaces between punctures often running as irregular carinae; propodeal concavity with the inferior median carina that is short and only 1/3 as long as the height of concavity; crest developed, with apical teeth that are less pointed than in *P. ishigakiense* (Fig. 172). Punctuation on gaster very similar to that in *P. ishigakiense*. Recurrent vein 2 of fore wing often very close to or even connected with intercubital vein 3.

Black, with the following parts orange yellow or orange: transverse frontal marking, upper half of clypeus, small triangular marking at the base of mandible, antennal scape below, a pair of markings in the dorsal part of pronotum anteriorly (these extend slightly into the anterior vertical face of pronotum), posterior horizontal part of gastral tergite 1 (medially deeply incised), a wide apical band on tergite 2 (often widely incised in the middle), narrow apical bands on tergites 3 and 4 (sometimes reduced or lost) and very rarely on tergite 5, stripe on the anterior face of fore tibia.

In the material from Kyūshū and Tane-ga-shima, the clypeus is often largely orange.

Male. Clypeus nearly as high as wide, widely emarginate at apex, without defined flattened area. Tergites 2 and 3 with small lateral yellow markings at apex. Tibiae of all the legs usually with yellow markings.

Material examined. Honshū: *Miyagi-ken* - 1 ♀, Tsuchitōi, Sendai, 9 viii 1977 (K. Goukon); *Niigata-ken* - 1 ♀, "Echigo", 26 vii 1938 (Nohira), 2 ♂ ♂, "Echigo", 9-21 viii 1948 (Nohira), 1 ♂, Fukushima-gata, Toyosaka, 12 viii 1978 (HI), 1 ♀, Shibata, 3 ix 1979 (HI); *Tōkyō-to* - 1 ♂ 2 ♀ ♀, Ōta-ku, 26 viii 1971 (M. Furukawa); *Saitama-ken* - 2 ♂ ♂, Ōmiya, emerged from a nest on 10 v 1976 (collected by YM in 1975 & reared by SKY); *Ibaraki-ken* - 1 ♀, Tsuchiura, 29 viii 1976 (SKY); *Kyōto-fu* - 1 ♀, Goshō, 11 vii 1955 (K. Iwata); *Ōsaka-fu* - 1 ♂, Iwawaki, Kawachi, 6 vi 1964 (H. Katayama); *Hyōgo-ken* - 1 ♀, Ōgi-no-sen, Tajima, 15 vii 1963 (H. Yuasa), 2 ♀ ♀, Sasayama, Tamba, 24 viii 1952 (K. Iwata), 1 ♂, same loc., 2 vi 1964 (H. Katayama); *Okayama-ken* - 1 ♀, Kanagawa, 9 vi 1960 (K. Iwata); *Shimane-ken* - 1 ♀, Kawatsu, Matsue, 16 vi 1985 (N. Sugiura), 1 ♀, Honjō,

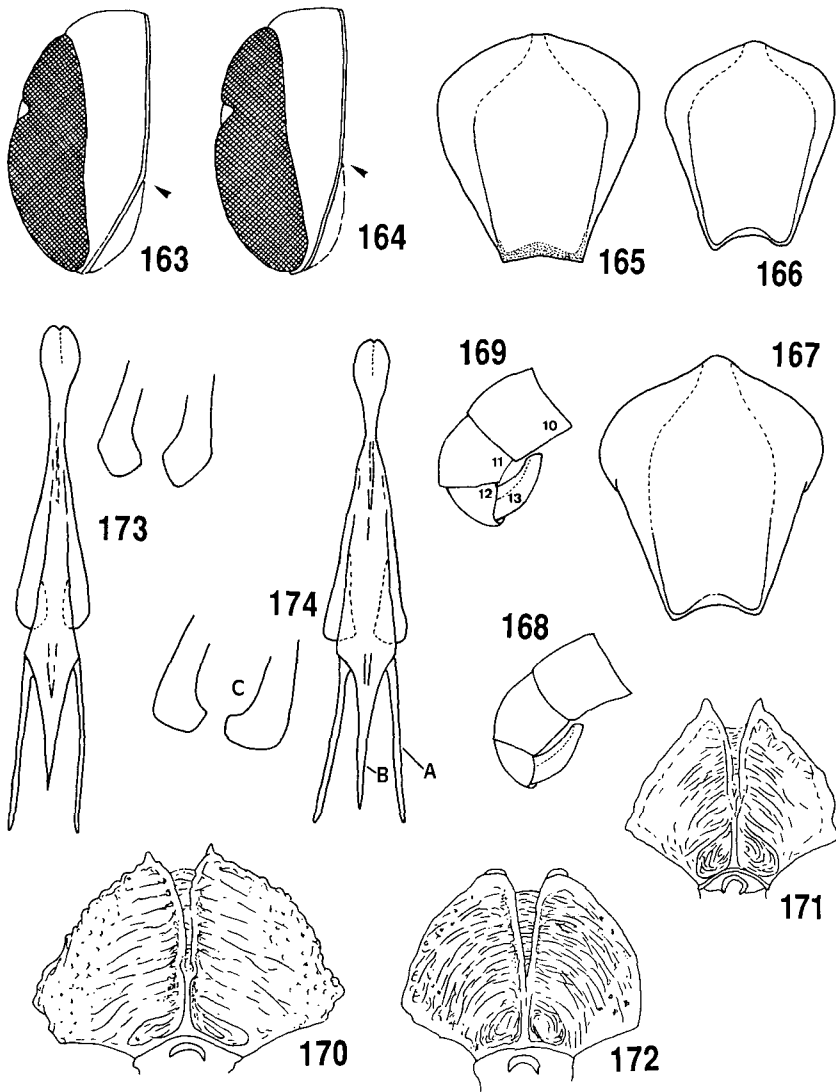

Figs. 163-174. Morphological characters in the Japanese species of *Pararrhynchium* (168,169, original; others after Yamane & Tano, 1983). Head in profile of *ishigakiense* (163) and *ornatum* (164); female clypeus (lateral lobes omitted) of *ishigakiense* (165), *tsunekii* (166) and *ornatum* (167); terminal segments of male antenna of *ishigakiense* (168) and *ornatum* (169); propodeum (posterior view) of *ishigakiense* (170), *tsunekii* (171) and *ornatum* (172); aedeagus of male genitalia (dorsal view) of *ishigakiense* (173) and *ornatum* (174)(A, apodeme; B, basal lobe; C, ventral view of ventral process).

Matsue, 24 vii 1986 (N. Sugiura).

Awaji-shima: 2 ♀, 18 viii 1954 (T. Mori).

Shikoku: *Ehime-ken* - 1 ♀, Matsuyama, 10 viii 1969 (HI); *Tokushima-ken* - 1 ♀, Mt. Tsudayama, Tokushima-shi, 28 vii 1964 (H. Iwasaki); *Kôchi-ken* - 1 ♂, Asakura, Kôchi-shi, 5 vi 1974 (SI).

Kyûshû: *Fukuoka-ken* - 1 ♀, Kurogi, 1 viii 1983 (Y. Takai); *Nagasaki-ken* - 1 ♀, Haraguchi, Ômura, 4 ix 1966 (R. Ohgushi), 1 ♀, same loc., 18 viii 1967 (R. Ohgushi); 1 ♀, Kawadana, 6 viii 1976 (J. Nakayama); *Kagoshima-ken* - 1 ♀, Ônejime, Ôsumi, 3 ix 1978 (H. Nagase), 1 ♀, Meiwa, Kagoshima-shi, 6-17 viii 1981 (SKY).

Tsushima Is. (Nagasaki-ken): *Shimo-agata* - 1 ♀, Kusudama-jinja, Tsutsu, 23 viii 1979 (I. Hiura).

Gotô Is. (Nagasaki-ken): *Nakadôri-jima* - 1 ♀, 9 viii 1976 (J. Nakayama).

Island close to Kagoshima-ken-hondo: *Akune-ôshima* - 1 ♀, 5 viii 1983 (SKY).

N. Ryukyus: *Tane-ga-shima* - 1 ♀, Shimama, 6 viii 1916 (H120), 1 ♂, Nishi-no-omote, 9 viii 1916 (H117), 1 ♀, 20 vii 1961 (AN). (Ogata & Nagase, 1987, recorded this species from Nakatane-chô of this island based on material collected between 1982 and 1986.)

Distribution. Honshû (rare in northern part); Awaji-shima; Iwai-jima; Shikoku; Kyûshû; Tsushima Is. (*Shimo-agata*); Gotô Is. (*Nakadôri-jima*); *Akune-ôshima*; Ôsumi Is. (*Tane-ga-shima*). China.

Biology. This species in Japan constructs its nests in reed or bamboo tubes. The nesting proceeds very slowly because the female wasp does not close a cell until her larva becomes large (Iwata, 1938a; referred to as *Ancistrocerus ornatus*). It took, for example, 23 days to complete a nest finally consisting of five larval cells and one empty cell. Each cell might have been completed in 4 or 5 days. The female wasp was observed to guard the cell in which young larva was growing for the greater part of daytime and through night. By the time when the last cell was closed with mud the wasplings in the first three cells had finished to spin their cocoons (Iwata, 1938a). Apparently this species provisions progressively, thus representing a subsocial stage (Iwata, 1971). In total 45 prey caterpillars were brought into a cell for which a continuous observation was made (Iwata, 1938a). Prey consists of the larvae of several species of Microlepidoptera.

Parasitoids: a chalcid wasp, and *Macrosiagon nasuta* (Coleoptera, Rhipiphoridae) (Iwata, 1938a).

Pararrhynchium tsunekii Tano et Sk. Yamane
(Figs. 166, 171, 182)

Pararrhynchium tsunekii: Yamane and Tano, 1983, Mem. Kagoshima Univ. Res. Center S. Pac., 4: 120-121, fig. 4, 7 (♀) (type loc.: Amami-ôshima).

Japanese name: Amami-kabafu-dorobachi.

Female. Similar to *P. ornatum ornatum* but differs in the following details: clypeus more deeply emarginate at apex; flattened part of clypeus more clearly defined (Fig. 166) and more finely punctate; thorax more slender (mesoscutum longer than wide); upper teeth of superior carina of propodeum rather sharp (Fig. 171); metanotum without distinct median furrow; punctures on gastral tergites much finer.

Black, with the following parts yellow or orange: basal triangular marking on mandible, frontal spot (lost in one specimen), very small spot behind eye, vertical face of gastral tergite 1 largely, other parts of tergite 1 almost wholly, tergite 2 laterally and apically, two large basal markings on sternite 2, spot at each postero-lateral angle of sternite 2. Mandible dark ferruginous. Antennal scape below ferruginous. Tibiae and tarsi

tinged with red; apical segments of tarsi brownish.

Male unknown.

Material examined. C. Ryukyus: *Amami-ôshima* - 1♀, Shimmura, 28 vii 1967 (TM)(holotype), 1♀, Santarô Pass, 23 vii 1967 (TM)(paratype).

Distribution. Amami Is. (Amami-ôshima).

Biology. No information is available.

Pararrhynchium oceanicum Sk. Yamane, sp. nov.

(Figs. 175-178)

Japanese name: Tsuya-kabafu-dorobachi.

Diagnosis. Female. Head slightly wider than high, rather finely and sparsely punctate; punctures smaller than interspaces even on the gena. Clypeus higher than wide, almost impunctate and shining, apically moderately emarginate (Fig. 175). Interantennal keel blunt; frons shining, with a depression just above the keel. Vertex elevated behind posterior ocelli; cephalic foveae situated in a depressed region between posterior ocelli and the elevated part; the depression dull and with a few distinct punctures; the narrow space between the elevated part and occipital carina irregularly punctate (Fig. 177). Occipital carina less developed than in *P. ornatum*, not strongly bent so that gena gradually narrowed toward the base of mandible. Postgena very finely and sparsely punctate. Mandibles each with four blunt teeth and rather sharply pointed apical one. Maxillary palp 6-segmented; labial palp with 4 segments, of which the terminal one is the shortest. Anterior vertical face of pronotum shining; punctation on it similar to that in *P. ornatum* but finer and sparser. Dorsal and lateral parts of pronotum relatively densely punctate but never reticulate. Mesoscutum shining, with micropunctures all over the disc and larger punctures in the anterior half of the disc; prescutal furrow distinct, measuring about half the length of the disc. Posterior end of tegula slightly exceeding that of posttegula. Scutellum very finely and sparsely punctate, shining, with a faint median longitudinal line, and with a distinct transverse furrow with more than ten short carinae on the border of mesoscutum. Mesopleuron without epicnemial carina; epicnemium almost impunctate. Mesepisternum with relatively weak and sparse punctures; mesepimeron superficially punctate and striate. Metanotum without distinct median furrow; punctures stronger than on scutellum. Metapleuron almost impunctate, with feeble carinae in upper portion. Propodeum without shelf; dorsal face relatively strongly and densely punctate; lateral part and concavity without distinct punctures or carinae, and dull; crest undeveloped; inferior median carina half as long as the height of concavity (Fig. 178). Gastral segment 1 narrower than segment 2. Anterior vertical face of tergite 1 very weakly punctate, with a median longitudinal carina; transverse carina separating the anterior face from posterior horizontal part weak and blunt; horizontal part relatively finely punctate (interspaces usually larger than punctures), with a shallow median depression near apical margin. Punctation on tergite 2 sparser than on tergite 1; other tergites with only micropunctures. Gastral sternite 1 without distinct punctures or carinae. Sternite 2 very weakly punctate; narrow basal area with strong longitudinal carinae; other sternites with only micropunctures.

Black, with yellow and rufous markings (Fig. 176). Yellow are: clypeal base widely,

frontal marking connected by a bar with the yellow part of clypeus, a stripe on antennal scape below, a marking on temple, triangular basal marking on mandible, anterior vertical face of pronotum largely, a pair of large markings on pronotum dorsally, a pair of spots on mesoscutum, scutellum largely, tegula basally, dorsal mesepisternum, spot on ventral mesepisternum, metanotum largely, dorsal part of propodeum, lateral parts of propodeal concavity, apical portion of the lateral part of propodeum (all these propodeal markings are connected), narrow apical bands on tergites 1-4, those on sternites 2-4, coxae except for posterior faces of all legs, femora and tibiae extensively. Mandible ferruginous. First two gastral segments largely rufous. Tarsi of all legs dark brown. Wings brownish-infumated.

Holotype. ♀, Fukiage-dani, Chichi-jima, Ogasawara Is., 18 vi 1972 (Y. Kusui).

Paratype. ♀, Tsutsuji-yama, Chichi-jima, Ogasawara Is., 12 vii 1972 (Y. Kusui).

Distribution. Ogasawara (Bonin) Is. (Chichi-jima).

Biology. No information is available.

Pararrhynchium oceanicum miyanoi Sk. Yamane, ssp. nov.

Diagnosis. Female. Structure as in the nominotypical form. Black, with yellow and rufous markings. Yellow are: upper lateral part of clypeus, triangular marking on mandibular base, small interantennal marking (lost in one specimen), transverse frontal marking, spot on temple, horizontal part of pronotum anteriorly (the marking extends onto the anterior vertical face of pronotum), relatively large spot under wing base, tegula except for center and margins, two large spots on scutellum, two transverse spots on metanotum, dorsal part of propodeum extensively, apical band on gastral tergite 1 (not clearly demarcated anteriorly), those on tergite 2 and sternite 2, irregular spots in apical portion of tergite 3 and sternites 3 and 4, anterior face of coxae below of all legs, apical half

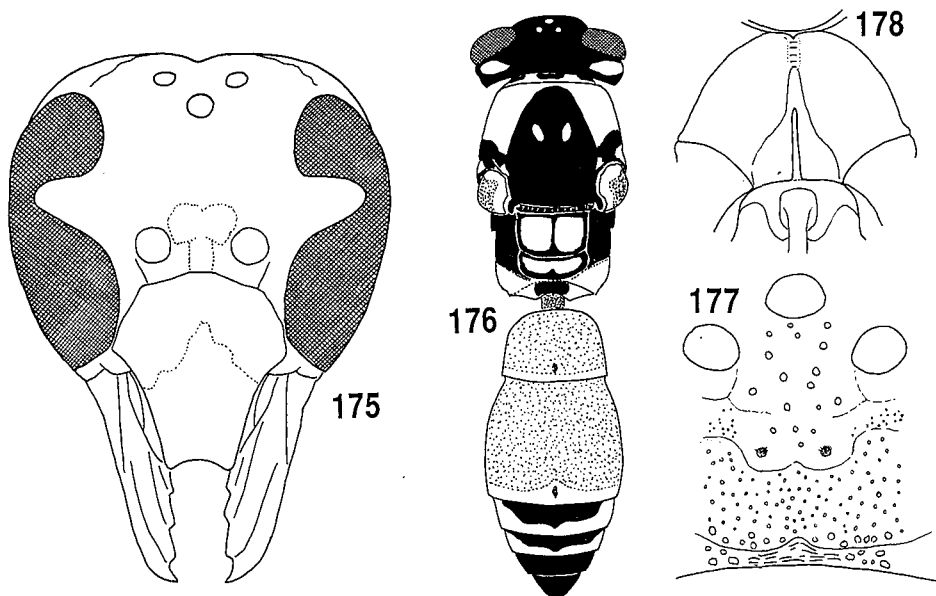

Figs. 175-178. *Pararrhynchium oceanicum* sp. nov. (♀). 175, head in frontal view; 176, body color pattern; 177, median part of vertex; 178, propodeum in posterior view.

of fore and mid femora, outer face of tibiae of all legs. Gastral segments 1 and 2 almost wholly rufous. Line on antennal scape below dirty yellow.

Similar to the nominotypical form, but differs therefrom in the following points: yellow pronotal marking less extensive, propodeal concavity wholly black, rufous markings on gastral segments 1 and 2 darker, legs much less extensively marked with yellow, and wings blackish-infumated. This form quite resembles the Haha-jima form of *Stenodynerus ogasawaraensis* in color pattern.

Holotype., Kitakou, Haha-jima, Ogasawara Is., 21 v 1989, S. Miyano leg.

Paratypes. 1, Omotobashi, Haha-jima, 24 v 1989 (S. Miyano), 1, same loc. 10 xii 1989, from a nest (S. Miyano).

Distribution. Ogasawara (Bonin) Is. (Haha-jima).

Biology. This form may be a tube renter.

Genus *Orancistrocerus* Vecht

Orancistrocerus Vecht, 1963, Zool. Verh. 60: 99-101 (type species: *Odynerus drewseni* Saussure, 1857, original designation).

Japanese names: Entotsu-dorobachi Zoku (Ô-kabafusuji-dorobachi Zoku; Ô-kabafu-dorobachi Zoku).

This genus has few autapomorphies, and is separated from the related genera by the combination of the following characteristics: cubital (submarginal) cell 3 further away from the apex of the radial (marginal) cell; gastral tergite 1 with a distinct transverse ridge separating the anterior vertical face from the posterior horizontal part; anterior margin of clypeus wide, more or less emarginate; labrum of female rather densely covered with long stiff hairs (Fig. 179); parastigma of fore wing at least half as long as stigma; propodeum without a shelf; propodeal declivity not margined with a crest (Vecht, 1963).

Only four species have been known from eastern Asia. In Japan, a single species, *O. drewseni*, is widely distributed chiefly on the mainlands.

Orancistrocerus drewseni drewseni (Saussure)

(Figs. 119, 179-181)

Odynerus drewseni Saussure, 1857, Ann. Soc. Entomol. Fr. (3)5: 318 (type loc.: China (?)).

Rhynchium flavomarginatum: Matsumura, 1911, Thous. Ins. Jpn. Suppl. 3, p. 112, pl. 39, fig. 15; 1930, Ill. Thous. Ins. Jpn. 2, p. 14, pl. 2, fig. 15; 1931, 6000 Ill. Ins. Jpn.-Emp. p. 16, no. 79 (misidentification).

Odynerus (Ancistrocerus) fukaianus Schulthess, 1913, Ark. Zool. Stockholm, 8: 4, 9, fig. 8 (group *Euancistrocerus*) (♀) (type loc.: Harima, Honshû); 1934, Arb. Morph. Tax. Entomol. 1: 71 (in key; *fukayanus* !); Yasumatsu, 1938, Ins. Jpn. Ill. Icon. Col. Nat. Dep. p. 359, fig. 628.

Ancistrocerus fukaianus: Sonan, 1938, Trans. Nat. Hist. Soc. Formosa, 28: 79; Giordani Soika, 1941, Boll. Soc. Venez. Stor. Nat. 2: 238; Yasumatsu, 1950, Icon. Ins. Jpn. 2nd ed. p. 1457.

Orancistrocerus drewseni: Ishikawa, 1965, Icon. Ins. Jpn. Col. Nat. Ed. 3, p. 297, pl. 149, fig. 1.

Orancistrocerus drewseni drewseni: Vecht, 1963, Zool. Verh. 60: 102-103; Yamane and Tano, 1983, Mem. Kagoshima Univ. Res. Center S. Pac. 4: 122.

Japanese names: Entotsu-dorobachi (Ô-kabafusuji-dorobachi; Ô-kabafu-dorobachi).

Diagnosis. Female. Body length (h+th+t1+2): 12.5-16.5 mm. Fore wing length: 12.5-14.0

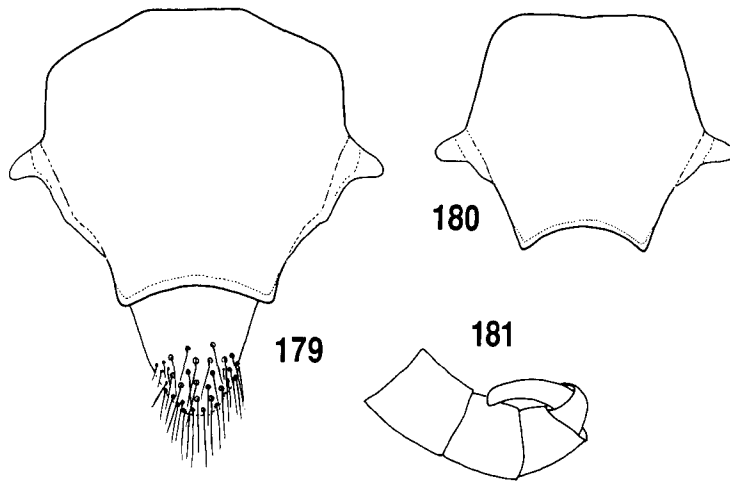

Figs. 179-181. *Orancistrocerus drewseini*. 179, female clypeus and labrum; 180, male clypeus; 181, terminal segments of male antenna. 180 and 181 are based upon a Korean specimen.

mm. Head subcircular, densely punctate. Clypeus slightly wider than high, medially striate and laterally punctate; apical margin wide, shallowly emarginate (Fig. 179). Interantennal keel blunt. Depression for cephalic foveae ill defined; area around the depression impunctate; distance between the foveae as long as that between the posterior ocelli. Anterior vertical face of pronotum smooth, shining, with a few punctures; posterior horizontal part densely punctate. Mesoscutum densely punctate; punctures running into longitudinal striae. Scutellum more coarsely sculptured than mesoscutum. Mesopleuron with large punctures densely, somewhat reticulate; epicnemium well defined by epicnemial carina, smooth but not shining. Metanotum sloping posteriorly, with large punctures. Metapleuron with a few punctures. Propodeum without shelf; concavity shallow, with a median carina which is interrupted at some distance from the tip, with ill-defined large punctures; dorsolateral face with large punctures; lateral side above with punctures and below with transverse carinae. Gastral segment 1 narrower than segment 2. Anterior vertical face of tergite 1 with small, sparse punctures; tergites 1, 3-5 strongly and densely punctate; punctation on tergite 2 much finer except in basal and apical narrow zones; tergite 6 without large punctures. Narrow basal part of sternite 1 impunctate; posterior part weakly striate. Sternite 2 anteriorly with strong short carinae; posterior portion somewhat shining, sparsely punctate; punctures coarser near its base. Punctures on other sternites much finer.

Black, with the following parts orange or orange yellow: clypeus, a transverse frontal mark with a median projection toward clypeus, antennal scape below, a basal triangular marking on mandible, relatively wide apical bands on tergites 1 and 2. Mandible largely, antennal flagellum below, upper faces of mid and hind femora apically brownish or rufous. Wings dark brown.

Male. Not examined.

Material examined. Honshû: *Yamagata-ken* - 1 ♀, Oguni, 1 viii 1976 (HI), 1 ♀, Nan'yô, 16 vii 1976 (HI), 1 ♀, same loc., 26 vii 1981 (HI); *Niigata-ken* - 1 ♀, Shibata, 18 vi 1967 (HI), 3 ♀ ♀, Nagaoka, 10 vii 1976 (SKY), 3

♀ ♀, Shibata, 7 vii 1976 (SKY), 5♀ ♀, Akadani, Shibata, 3 vii 1977 (A. Seino & H. Koike), 1♀, Takane, 2 vii 1978 (HI), 3♀ ♀, Iwakuzure, 17 ix 1981 (KB), 6♀ ♀, Senami, 11-30 vii 1981 (KB), 1♀, same loc., 11 ix 1981 (KB), 1♀, same loc., 27 vi 1983 (KB), 1♀, same loc., 10 vii 1984 (KB); *Tochigi-ken* - 1♀, Utsunomiya, 2 viii 1970 (T. Hasegawa); *Hyōgo-ken* - 1♀, Sasayama, Tamba, 7 viii 1963 (K. Iwata), 1♀, same loc., 13 viii 1965 (H. Katayama); *Ōsaka-fu* - 5♀ ♀, Iwawaki, Kawachi, 6-10 vi 1964 (H. Katayama); *Kyōto-fu* - 1♀, Minna-ji, 20 vi 1958 (K. Iwata); *Wakayama-ken* - 1♀, Kōyasan, 7 viii 1955 (K. Iwata); *Shimane-ken* - 1♀, Sugata, Matsue, 9 viii 1985 (N. Sugiura), 1♀, Hikimi, 8 xi 1987 (N. Sugiura).

Sado-ga-shima: 1♀, Tagirisu, Mano, 23 ix 1981 (KB).

Awaji-shima: 1♀, 10 viii 1954 (T. Mori).

Shikoku: *Tokushima-ken* - 2♀ ♀, Tsudayama, Tokushima-shi, 22-24 viii 1964 (H. Iwasaki).

Kyūshū: *Fukuoka-ken* - 1♀, Kurogi, 28 vii 1983 (Y. Takai), 2♀ ♀, same loc., 30 viii 1984 (Y. Takai); *Miyazaki-ken* - 1♀, Hinokage, Nishiusuki, 5 vi 1987 (K. Suzuki); *Kagoshima-ken* - 1♀, Takachiho-no-mine, Kirishima, 8 vi 1973 (K. Ōhara), 1♀, Shiroyama, Kagoshima-shi, 10 vii 1981 (SKY).

Gotō Is. (Nagasaki-ken): *Nakadōri-jima* - 1♀, 11 viii 1976 (J. Nakayama).

Tsushima Is. (Nagasaki-ken): *Shimo-agata* - 2♀ ♀, Izuhara, 26 vii 1986 (K. Nakamine).

N. Ryukyus: *Tane-ga-shima* - 1♀, Nishi-no-omote, 13 v 1981 (SKY), 1♀, same loc., 4 viii 1983; *Yaku-shima* - 1♀, Miyanoura, 11 viii 1981 (SKY).

Distribution. Honshū; Sado-ga-shima; Awaji-shima; Shikoku; Kyūshū; Gotō Is. (Nakadōri-jima; Fukue-jima; Naru-jima); Tushima Is. (Shimo-agata); Amakusa Is. (Kamishima); Ōsumi Is. (Tane-ga-shima; Yaku-shima). China.

Taxonomic notes. Judging from the figures the females of "*Rhynchium flavomarginatum* Sm." in Matsumura (1911, 1930, 1931) apparently have pale markings on alitrunk and gastral tergites 3-6 (?). However, Matsumura did not refer to these markings at all in the text: "Body black, densely punctate, with sparse short hairs. Clypeus, marking between antennal bases, scape below, apical markings on 1st and 2nd abdominal segments orange yellow...." (translation by me). The figures seem incorrect.

Biology. The nesting habits and life history of this form were studied by Iwata (1938a;

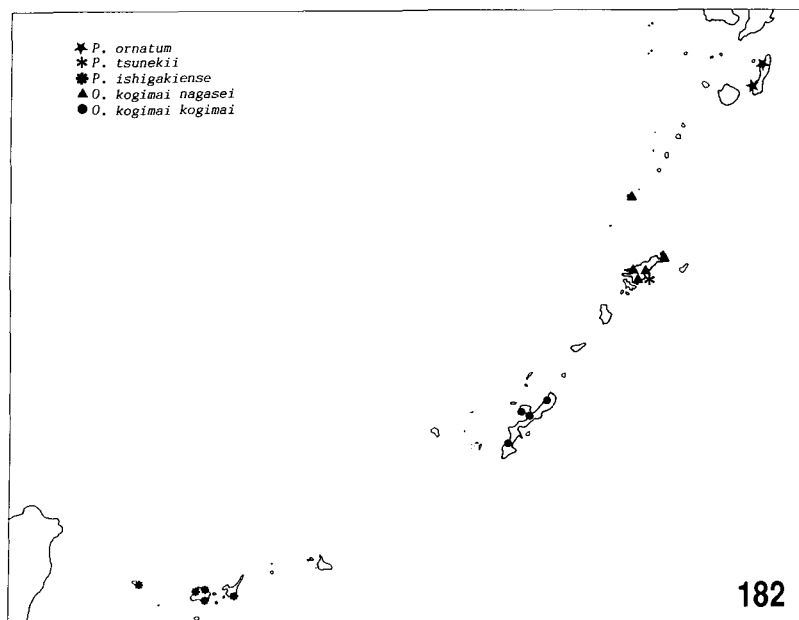

Figs. 182. Distribution of *Okinawepipona* and *Pararrhynchium* species in the Ryukyus.

referred to as *Ancistrocerus fukaianus*). Additional data are given in a text written in Japanese (Iwata, 1983). A series of beautiful photos of nesting females and nests are given in Iwata (1982). Itino (1986a) made a comparative study on the population ecological aspects of this form and *Anterhynchium flavomarginatum micado*. Iwata (1939b) studied the Taiwanese subspecies *ingens* (Schulthess) that had a similar nesting behavior. *O. aterrimus erythropus* (Bingham) also shows a similar pattern of nesting behavior (Iwata, 1964).

The Japanese population of this form is very probably parthenogenetic, because only females are collected in the field and from nests. In the Korean population (also belonging to the subsp. *drewseni*) and the Taiwanese subspecies *ingens* the male is commonly found.

Female wasps build their gourd-shaped nests of clay in cavities of wood, depressions on rocks and stones, bamboo tubes, etc. It was once observed that a nest was built on a rootlet of a plant hanging from a clayey cliff (Iwata, 1938a). When bamboo tubes with a small diameter are used, they are simply partitioned into cells by clayey wall. The nest is provided with a delicate chimney (ca. 10 mm diam.) of variable length which is built downward from the mouth of nest and removed after the completion of nest. A nest contains 1-4 (rarely 5) cells that are linearly arranged; each cell is supplied with 5-16 caterpillars before the hatching of wasp egg, and 24-46 (m=36) in total. These caterpillars are progressively provided by the mother wasp with the growth of her young. When the nest is disturbed, the mother wasp may abandon the prey in the cell under provisioning and make empty cells to hide the inner larval cells already completed. The female may lay a maximum of six eggs. Two generations occur in a year. According to Itino (1966c) adult daughter wasps generally do not disperse, sometimes reutilize mother nests or construct their nests on those of preceding generations. As a result nest aggregations are not rare. Prey: Larvae of Pyralidae, Gelechiidae, Tortricidae, Noctuidae (Lepidoptera) (Iwata, 1938a, 1983).

Parasite: *Pseudoxenos iwatai* (Strepsiptera, Stylopidae) (Iwata, 1938a, 1983). Parasitoids: *Anthrax distigma* ? (Diptera, Bombyliidae), *Amobia distorta* (Sarcophagidae), *Megaselia* sp. (Phoridae), *Acroricnus ambulator* (Hymenoptera, Ichneumonidae), a chrysidid, and *Macrosiagon nasuta* (Coleoptera, Rhipiphoridae) (Iwata, 1938a; Itino, 1986a).

Genus *Ancistrocerus* Wesmael

Ancistrocerus Wesmael, 1836, Bull. Acad. R. Belg. 3: 45 (subgenus of *Odynerus* Latreille)(type species: *Vespa parietum* Linnaeus, designated by Giraud, 1879); Bequaert, 1925, Trans. Amer. Entomol. Soc. 51: 85 (as subgenus of *Ancistrocerus* Wesmael, s. lat.); Carpenter, 1986, Psyche, 93: 64 (as genus); Blüthgen, 1961, Faltenwespen Mitteleuropas, p. 151 (as genus).

Euancistrocerus Dalla Torre, 1904, Gen. Ins. 19: 36 (new name).

Japanese name: Suji-dorobachi Zoku.

Diagnoses for this taxon have been given by various authors, though that in the key to the European eumenid genera by Blüthgen (1961) may be most useful.

Head, thorax, propodeum, gastral tergite 1 (+ 2), and sternites 1 and 2 generally with abundant long hairs. Head with a rounded depression (Scheitelgrübe) for cephalic foveae on the vertex in the female (rarely evanescent). Supraclypeal area with a rather deep pit just below each antennal socket. Front corners of pronotum more or less angled, often sharply pointed in the male (Figs. 192-198). Notaulices absent. Prescutal groove usually

inconspicuous. Epicnemial carina absent. Metanotum posteriorly not spinose. Tegula relatively slender, produced and more or less tapering caudally (Fig. 191), and not strongly punctate. Propodeum with no or at most a narrow shelf (in at least Japanese species), with a series of sharp ridges enclosing the posterior face (propodeal concavity) that is flat rather than concave, but the superior ridges sometimes much reduced. Lateral ridges and/or posterolateral angles of propodeum sometimes developed. Punctuation on tergites 1 and 2 generally weak. The anterior vertical face of tergite 1 clearly separated from the horizontal disc by a sharp transverse carina; tergite 1 without longitudinal furrow. Tergite 2 without yellow lateral spots. Gastral color pattern is relatively stable within a species and is useful in separating species (Figs. 214-220).

Earlier authors (e.g., Saussure, 1852-8; Bequaert, 1918, 1925) lumped almost all the species of "*Odynerus*" with a transverse carina on tergite 1 into a group (*Ancistrocerus*). Bequaert (1925), however, wrote: "*Ancistrocerus* as at present understood is evidently polyphyletic. The transverse carina is evidently a structure acquired independently in several lines of descent among the Eumenidae". In the present paper I treat Bequaert's subdivision *Ancistrocerus* (proper) as a genus. This genus is widely distributed in the Palearctic and Nearctic regions, fewer number of species being found also in the Old and New World tropics. One Japanese species (*A. antilope*) is also found in both Europe and North America, showing a Holarctic distribution (cf. Krombein, 1979). Useful keys are available for the European species (e.g., Blüthgen, 1961; Yeo & Corbet, 1983).

Key to the Japanese species of *Ancistrocerus*

1. Body hairs very long; hairs on vertex distinctly longer than the distance between the posterior ocelli; all the tergites but the last one with long hairs; female antennal scape with many long hairs especially near its base. Male mandible with a large concavity in the middle on inner margin. Metanotum elevated above a level with the posterior portion of scutellum. Last tergite of the female with a yellow spot. Tegula marked with yellow. *A. oviventris oviventris* (L.)
- Body hairs shorter; hairs on the vertex as long as or shorter than the distance between the posterior ocelli; hairs on tergites 2-4(5) very short; female antennal scape without long hairs (if present, then few in number and inconspicuous). Metanotum not elevated, nearly at the same level as scutellum. 2
2. Metapleuron and lateral part of propodeum in the lower half smooth, with glaring luster. Posterior face of propodeum not striate, polished. Lateral ridge of propodeum in the male well developed, forming a flat wing. Terminal segment of male antenna thick and short, the apex not reaching the middle of segment 11. Yellow pronotal band widely interrupted medially. Female clypeus wholly black. *A. antilope antilope* (Panz.)
- Metapleuron and lateral part of propodeum in the lower half finely striate, wrinkled, or micropunctured, without glaring luster. Posterior face of propodeum often striate. Lateral ridge of propodeum not forming a distinct wing. Terminal segment of male antenna larger; the apex extending beyond the middle of segment 11 (if shorter, then it is slender and apically pointed). 3
3. Gastral tergites 1-4 each with a yellow apical band; last tergite without yellow spot in the female. Superior ridge of female propodeum much reduced, often almost absent. Female clypeus with a pair of upper yellow spots. In the male fore and mid femora

- extensively yellow on the anterior face. Sternite 2 distinctly angulate near the base.
 *A. nigricornis* (Curt.)
- Tergites differently marked with yellow. Superior ridge of female propodeum usually distinct. In the male fore and mid femur usually blackish, at most marked with yellow near its apex. 4
4. Female clypeus with two pairs of yellow spots, one near the base and the other near the apex. Tergites 1-4 with yellow apical bands; last tergite with a yellow spot in the female. Female tegula with anterior and posterior yellow spots. The male is not known in Japan.
 *A. parietinus* (L.)
- Female clypeus differently colored. At most tergites 1-3 with a yellow band. Tegula in both sexes wholly blackish brown. 5
5. Only tergites 1 and 2 with yellow apical bands. Female clypeus with a pair of yellow spots near its apex. Antennal flagellum in the female ferruginous below. Terminal segment of male antenna small; the apex not reaching the base of segment 11.
 *A. japonicus* (Schult.)
- Tergites 1-3 with yellow apical bands (the band on tergite 3 sometimes reduced or absent in the female). Female clypeus usually wholly black. Antennal flagellum in the female blackish below, at most brownish apically. Terminal segment of male antenna longer; the apex almost reaching the base of segment 11. 6
6. Body slender; in the female tergite 1 (as measured from the transverse carina to the apical margin) 5/3 times as wide as long. Female scutellum wholly black. In the male, antennal scape usually largely black; legs often without yellow markings, at most with them on the anterior face of fore and mid tibiae. *A. trifasciatus shibuyai* (Yasum.)
- Body more stumpy; in the female, tergite 1 two times as wide as long. Female scutellum almost always with yellow spots. In the male, antennal scape usually yellow below; legs more extensively yellow. *A. melanocerus* (D.T.)

Ancistrocerus japonicus (Schulthess)
 (Figs. 183, 192, 201, 202, 214, 221)

Odynerus (*Euancistrocerus*) *japonicus* Schulthess, 1908, Mitt. Schweiz. Entomol. Ges. 11: 285 (♀) (type loc.: Yokohama, Honshû); 1934, Arb. Morph. Taxon. Entomol. 1: 73 (in key).

Ancistrocerus japonicus: Vecht and Fischer, 1972, Hym. Cat. (n. ed.) 8: 113; Giordani Soika, 1986, Boll. Mus. Civ. Stor. Nat. Venez. 35: 150-152.

Japanese names: Yamato-suji-dorobachi (Kiobi-suji-dorobachi).

Diagnosis. Female. Body length (h+th+t1+2): 9.0-11.5 mm. Forewing length: 8.5-11.0 mm. Head slightly wider than high, densely punctate. Clypeus wider than high, apically shallowly emarginate; lateral angles of the emargination round (Fig. 201); punctuation rather superficial. Frontal keel distinct. Depression for cephalic foveae weakly defined; foveae close to each other. Temple, as seen from above, slightly wider than the superior lobe of eye. Distance between posterior ocelli approximately as long as distance between posterior ocellus and eye. Occiput sparsely punctate. Antenna relatively short; flagellum gradually widened toward apex until segment 8. Thorax coarsely and densely punctate. Each side of the anterior vertical face of pronotum with a transverse furrow; pronotal carina weak in dorsal part. Prescutal grooves only basally visible, not conspicuous; mesoscutum with a shallow longitudinal furrow on each side at a short distance from

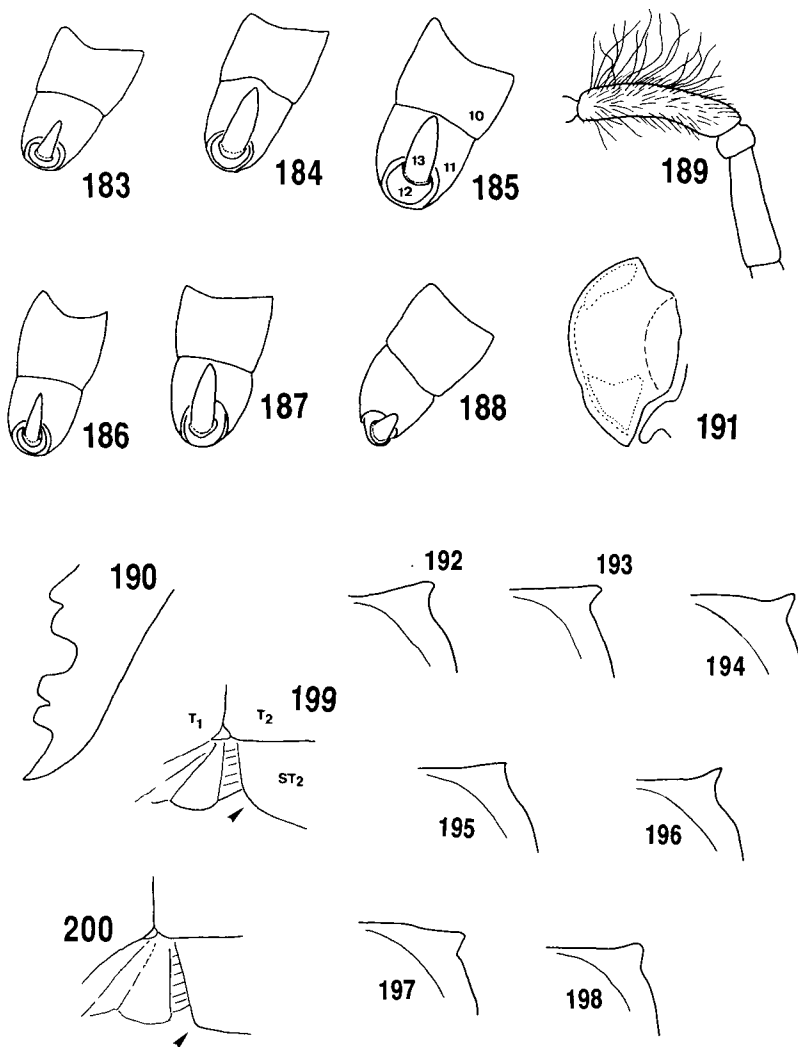

Figs. 183-200. Various characters in the Japanese *Ancistrocerus*. 183-188, segments 10-13 of male antenna in *japonicus* (183), *trifasciatus* (184), *melanocerus* (185), *nigricornis* (186), *oviiventris* (187) and *antilope* (188); 189, scape, pedicel and flagellar segment 1 of female antenna of *oviiventris*; 190, male mandible of *oviiventris*; 191, tegula and parategula of *nigricornis*; 192-198, right front corner of pronotum in *japonicus* ♂ (192), *trifasciatus* ♂ (193), *melanocerus* ♂ (194), *nigricornis* ♀ (195) and ♂ (196), *oviiventris* ♂ (197) and *antilope* ♂ (198); 199, 200, gastral segments 1 and 2 (profile) of *trifasciatus* (199) and *nigricornis* (200).

tegula; punctation on epicnemium fine and sparse; scutellum without longitudinal furrow. Metanotum without horizontal part, nearly directly sloping to propodeum; metapleuron without distinct punctures. Propodeal shelf very narrow, with a median pit; propodeal concavity nearly wholly enclosed by ridges, obliquely and shallowly striate, with a complete vertical carina; superior ridge sometimes reduced to some extent in its lower

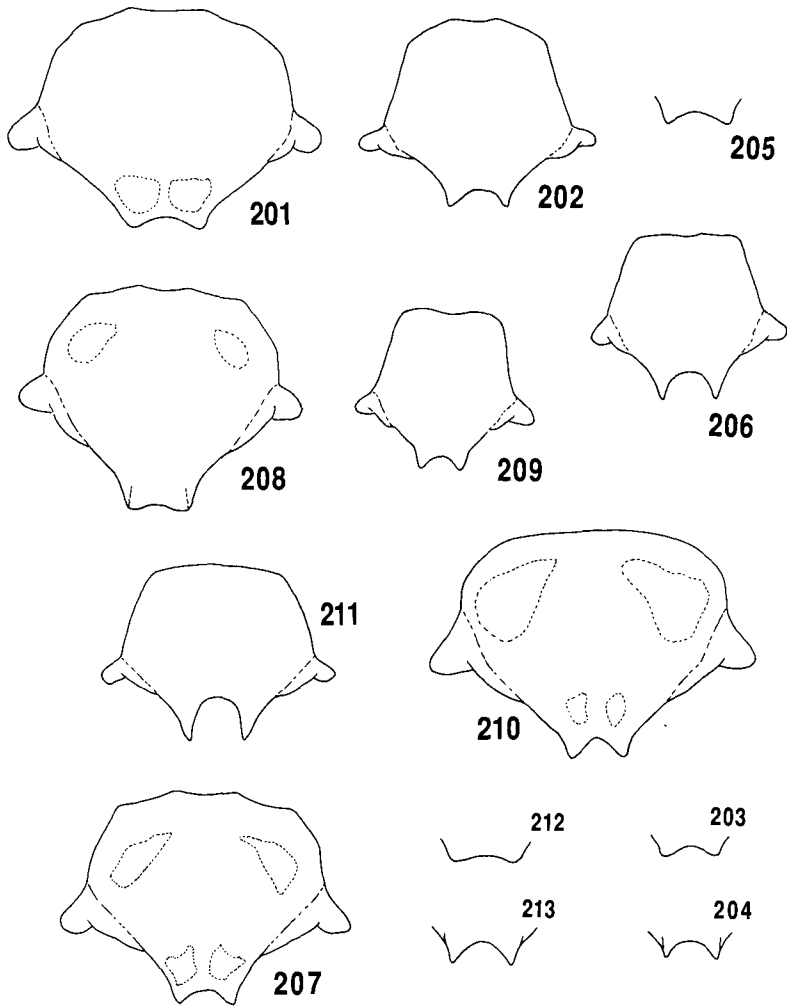

Figs. 201-213. Clypeus of Japanese *Ancistrocerus* species. 201, *japonicus* ♀; 202, ditto ♂; 203, *trifasciatus* ♀; 204, ditto ♂; 205, *melanocerus* ♀; 206, ditto ♂; 207, *parietinus* ♀; 208, *nigricornis* ♀; 209, ditto ♂; 210, *oviventris* ♀; 211, ditto ♂; 212, *antilope* ♀; 213, ditto ♂.

part; dorsolateral part of propodeum with large punctures; lateral ridge almost absent; lateral face indistinctly striate. Anterior vertical face of gastral tergite 1 only superficially and sparsely punctate in its upper part; punctuation on posterior horizontal part much denser. Tergite 2 much more finely and sparsely punctate than tergite 1. Apical half of tergites 3-5 rather strongly punctate; last tergite almost impunctate. Apical part of sternites 2-5 rather strongly punctate; last sternite impunctate.

Black; the following parts yellow or orange yellow: a pair of spots on clypeus apically, a frontal spot, a small spot between antennal socket and eye, a very short line on temple, a triangular basal marking on mandible, antennal scape below, pronotal band medially interrupted and not extending to lateral face of pronotum, a narrow and regular apical

band on tergite 1, a wider apical band on tergite 2 (Fig. 214), posterolateral corners of sternite 2, anterior and apical part of fore femur, anterior face of fore tibia. Mandible blackish brown, apically rufous. Antennal flagellum below ferruginous.

Male. Body length (h+th+t1+2): 7.5-8.0 mm. Fore wing length: 7.0-7.5 mm. Similar to the female in structure and color pattern. Differs from the latter in the following details: head distinctly wider than high; clypeus nearly as wide as high, anteriorly more deeply emarginate; lateral angles of the emargination more sharply pointed (Fig. 202); clypeus nearly wholly yellow; mandible more extensively yellow; yellow spots on frons, between antennal socket and eye, and on temple much reduced and sometimes lost; pronotal band much reduced; anterior face of mid tibia often marked with yellow. Terminal segment of antenna very small; the apex not reaching the base of segment 11 (Fig. 183).

Material examined. Honshū: *Iwate-ken* - 1 ♀, 27 vi 1944 (Ogasawara), 1 ♀, Tamayama, 1968-69, reared from nest (SKY); *Niigata-ken* - 1 ♀, Senami, 9 vi 1979 (KB), 1 ♀, Shibata, 30 vi 198? (A. Seino); *Tōkyō-to* - 1 ♀, Okutama, 23 ix 1978, 2 ♀ ♀, same loc., iv-v 1978, reared from nest (Y. Tanaka), 1 ♂ 1 ♀, Nishitama, iv-v 1978, reared from nest (Y. Tanaka); *Nagano-ken* - 1 ♀, Takase-dani, Ōmachi, 20 vii 1982 (W. Miyata); *Yamanashi-ken* - 1 ♂ 1 ♀, Shioyama, iv-v 1978, reared from nest (Y. Tanaka); *Fukui-ken* - 1 ♀, Ashuwa, 17 v 1959 (TT), 1 ♂, Otani, 6 viii 1964 (TT), 1 ♀, Koike, Ōno, 22 ix 1968 (YH), 1 ♀, Asahimaesaka, 30 viii 1979 (TT), 1 ♀, Nagadani, Natashō, 25 vii 1980 (TM); *Ishikawa-ken* - 1 ♂, Koyajiri-sekkei, Mt. Hakusan, 17 vii 1984 (I. Togashi); *Gifu-ken* - 1 ♀, Kamiaizu, Kaminoho, Mugi, 5 viii 1981 (Y. Takai).

Sado-ga-shima: 1 ♂, 1987-88, reared from a nest (T. Ōnuma).

Shikoku: *Kōchi-ken* - 2 ♀ ♀, Engyōji, Kōchi-shi, 31 v 1931 (Y. Sugihara), 1 ♂, Kodakasa-yama, 21 v 1936 (H. Okamoto).

Kyūshū: *Kagoshima-ken* - 1 ♀, Saruga-jō, Tarumizu, v 1980, reared from nest (79T-6) (H. Nagase), 1 ♀, Takakuma, 19 vi 1981 (KT).

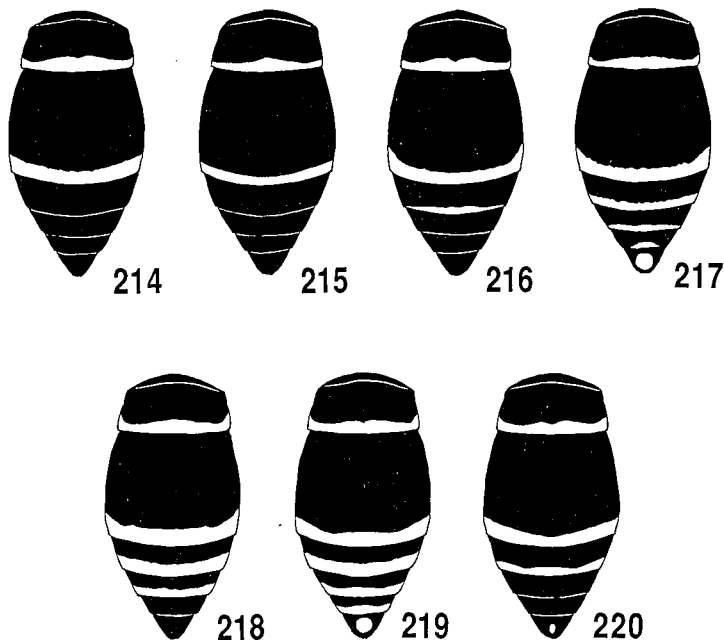

Figs. 214-220. Body color pattern in the Japanese *Ancistrocerus* species (♀). 214, *japonicus*; 215, *trifasciatus*; 216, *melanocerus*; 217, *parietinus*; 218, *nigricornis*; 219, *oviventris*; 220, *antilope*.

N. Ryukyus: *Yaku-shima* - 1 ♀, Ishizuka, 30 vi 1965 (K. Hashimoto), 1 ♂, Kosugidani, 20 v 1968 (A. Mori), 1 ♀, Onoaida, 23 iv 1982 (SI).

Distribution. Honshû; Sado-ga-shima; Shikoku; Kyûshû; Shika-no-shima (Fukuoka-ken); Ôsumi Is. (Yaku-shima).

Biology. According to Iwata (1938a), this species nests on depressed rocks or inscriptive stones, whose surfaces are always vertical and facing south or east. A completed nest studied by Iwata was constructed in an inscription deeply incised in granite, and contained eight cells attached to each other in a mass; the entire surface was thickly covered with "crépissage". Each cell is a cylindrical and elongate mud pot. However, I found a 1-celled nest made in a reed tube in Iwate-ken. In this case the cell was not a pot, but with a mud entrance plug (cell wall). Similar nests were found also on Sado-ga-shima (Ônuma, 1989a) and in Kagoshima-ken (Nagase, pers. comm.). Ônuma mentioned that the number of cells per tube nest ranged between 1 and 16 (usually between 2 and 6). Thus, this species seems to be either a tube-renter or a mud-dauber (sensu Spradbery, 1973). The brood cell is provided with six to seven lepidopterous caterpillars. The wasp has at least two generations a year in the Kansai District (Honshû), and overwinters as prepupal stage in the nest.

Parasitoids: an ichneumon wasp (Hymenoptera) and *Chrysis* sp. (Hymenoptera, Chrysididae).

Ancistrocerus trifasciatus shibuyai (Yasumatsu)
(Figs. 184, 193, 199, 203, 204, 215, 222)

Odynerus (*Ancistrocerus*) *shibuyai* Yasumatsu, 1938, Mushi, 11: 83 (♂ ♀) (type loc.: Osaka, Honshû); Vecht and Fischer, 1972, Hym. Cat. (n. ed.) 8: 117.

Ancistrocerus trifasciatus shibuyai: Giordani Soika, 1986, Boll. Mus. Civ. Stor. Nat. Venez. 35: 147-148.

Japanese name: Shibuya-suji-dorobachi.

Diagnosis. Female. Body length (h+th+t1+2): 9.0-10.5 mm. Fore wing length: 8.0-9.5 mm. Head as wide as high, densely punctate. Clypeus wider than high, distinctly punctate and somewhat carinate, apically very narrowly and shallowly emarginate; lateral teeth of the apical emargination blunt (Fig. 203). Temple moderately developed, as seen from above as wide as superior lobe of eye. Punctuation on gena and vertex finer than on frons. Depression for cephalic foveae ill defined; foveae very small and close to each other. Anterior ocellus slightly larger than posterior one; distance between the posterior ocelli as long as that between posterior ocellus and eye. Thorax rather depressed dorsoventrally, densely punctate. Anterior vertical face of pronotum with a transverse furrow on each side. Prescutal groove evanescent; epicnemium almost impunctate; punctuation on scutellum sparser than on mesoscutum. Metanotum gently sloping toward propodeum; metapleuron without punctures. Propodeum with a narrow shelf that is sloping and has a median pit. Propodeal concavity wholly enclosed by ridges, superficially striate, with a complete median carina. Dorsal face of propodeum with large punctures; lateral ridge not developed; lateral face finely and superficially striate. Punctuation on gastral tergites finer than in *A. japonicus*, especially on tergite 2. Tergites 3-5 and sternites 3-5 with relatively large punctures.

Black, with the following parts yellow: small triangular marking on mandible basally,

frontal spot, minute spot between antennal socket and eye, very minute spot on temple, apex of antennal scape below, narrow and short band on pronotum anteriorly, apical bands on tergites 1 and 2 (rarely also on 3) (Fig. 215), a complete apical band on sternite 2, anterior faces of fore and mid tibiae (the latter often wholly black). Mandible black, with brown teeth. Antennal flagellum almost wholly black.

Male. Body length (h+th+t1+2): 6.5-8.0 mm. Forewing length: 6.5-7.5 mm. Differs from the female in the following details: head wider than high; clypeus nearly as wide as high; front corners of pronotum distinctly produced (Fig. 193); mandible and clypeus yellow except periphery; 3-4 terminal segments of antenna partly rufous; yellow markings on head and thorax much reduced, sometimes partly lost. Antennal hook larger than in the preceding species; the apex almost reaching the base of segment 11 (Fig. 184).

Material examined. Hokkaidō: 1 ♀, loc. not stated, 4-10 viii 1928 (Uchida & Kōno), 1 ♀, Shikaribetsu, 24 viii 1934 (Uchida), 1 ♀, Sapporo, 25 viii 1935 (Y. Sugihara), 1 ♀, Tengū-dake, 21 vii 1935 (S. Sasaki), 1 ♂, Moiwā-yama, 25 v 1946 (S.F. Sakagami), 1 ♂, Moiwashita, Sapporo, 11 ix 1957 (TN), 1 ♂, Sōunkyō, 4 viii 1959

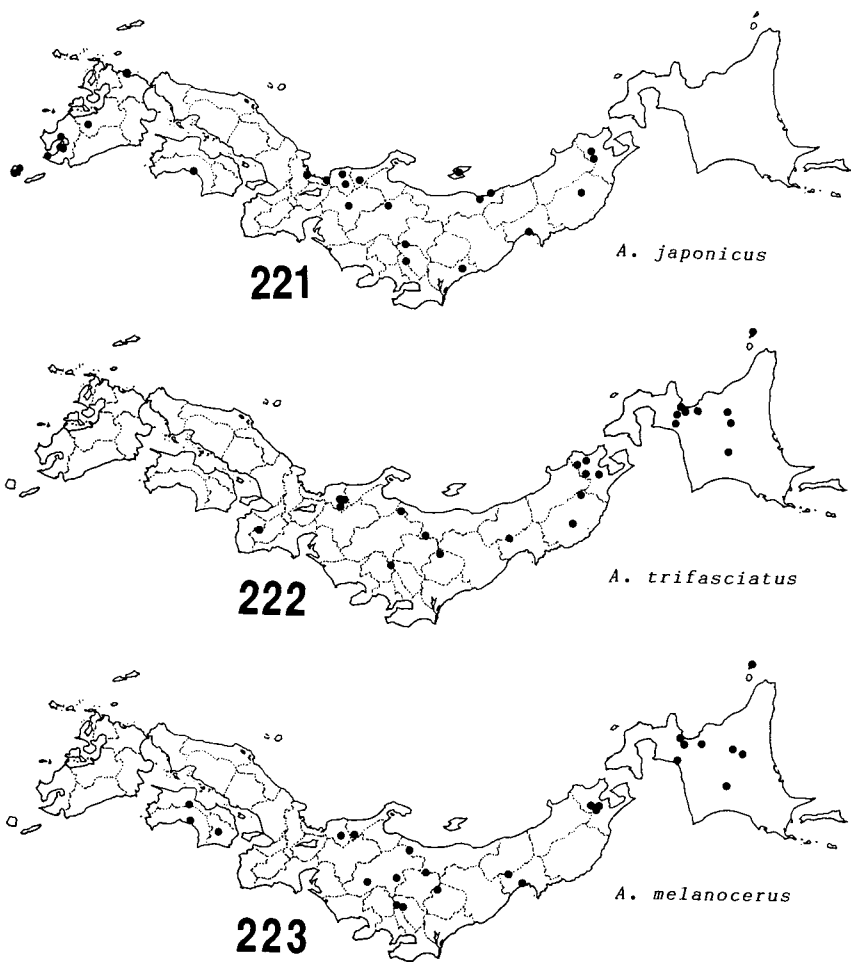

Figs. 221-223. Distribution of Japanese *Ancistrocerus* (I).

(H.D.), 1 ♀, Miyanomori, Sapporo, vi 1961 (Yamane), 1 ♀, same loc., 12 vi 1962 (T. Kubo), 1 ♀, same loc., 13 vi 1962 (SKY), 3 ♀ ♀, same loc., 8 vii 1965 (SY), 1 ♀, Teine-yama, 25 vii 1965 (SKY), 1 ♀, Kozawa, Shiribetsu, 2 viii 1968 (TN), 1 ♀, Jōzankei, vi 1971 (S. Aoki), 1 ♀, Bibai, 23 viii 1971 (K. Kamijo), 1 ♀, Bibai, 17 vi 1972 (M. Taira), 1 ♂, Shikotsu-ko, 17 vii 1977 (SKY), 1 ♀, Aizankei, 2-4 viii 1977 (TM), 1 ♀, Muine-yama, 20 viii 1977 (SKY), 1 ♀, Bibai, 13 vi 1978 (K. Kamijo), 1 ♀, Asahigawa, 6 viii 1979 (T. Inaoka).

Rebun-tō: 1 ♂, 26 vii 1951 (M. Konishi).

Honshū: *Aomori-ken* - 1 ♀, Sukayu, 18 viii 1968 (TN), 1 ♀, Iwaki-san, 8 viii 1982 (M. Yamada); *Iwate-ken* - 1 ♀, Ashiro, 6 ix 1979 (YM), 1 ♀, Mt. Hayachine, 31 vii 1979 (YM); *Miyagi-ken* - 1 ♀, Mt. Zaō, 27 vii 1979 (T. Nishioka), 1 ♂, same loc., 2 ix 1979 (K. Goukon), 1 ♂, same loc., 29 v 1982 (K. Goukon); *Niigata-ken* - 1 ♀, Mikuni Pass, 6 ix 1981 (KB); *Gumma-ken* - 2 ♀ ♀, Osawa, Nikkō, 16 vii 1978 (HI), 1 ♂, Kensetsu-daira, Okunikō, 31 vii 1982 (HI); *Saitama-ken* - 1 ♀, Karisaka, 26 vii 1974 (K. Hara); *Tochigi-ken* - 1 ♀, Chūzenji, 31 vii 1915 (E. Gallois); *Nagano-ken* - 1 ♂, Mt. Tenguhara, 12 ix 1982 (HI); *Yamanashi-ken* - 1 ♂ 2 ♀ ♀, Shiroyama, iv - v 1978, reared from nest (Y. Tanaka); *Fukui-ken* - 1 ♂, Ōno, 23 ix 1974 (YH), 1 ♀, same loc., 25 viii 1976 (YH), 1 ♀, Koike, 29 viii 1978 (H. Kurokawa), 1 ♂, Kanakusa-dake, Ikeda, 13 ix 1981 (H. Kurokawa); *Nara-ken* - 1 ♀, Obako-dake, 22 vii 1957 (K. Iwata).

Distribution. Hokkaidō; Rebun-tō; Honshū (central and northern parts). The nominotypical subspecies is widely distributed in the Palearctic region, from Europe in the west to Sakhalin and Kamchatka in the east (Vecht & Fischer, 1972).

Biology. According to Shibuya (1938) this form generally constructs one-celled nests in dry reed tubes; two-celled nests are rather rare. Caterpillars of leaf-rollers (microlepidopterous larvae) are stored in brood cells. In one case eleven caterpillars (135 mg in total) were found from in a cell (May 26 1934). The wasp constructs a double entrance plug; the inner wall is relatively thick, dirty black in color, and probably made of mud and sand grains mixed with wasp's saliva, while the outer one is made of yellowish, semi-transparent, sticky resin that is finally plastered with a few sand grains or fibers of weather-bitten wood on its outer surface. Though adult wasps are collected from May to September (see *Material examined* above), this form is univoltine and overwinters at prepupal stage in Kyōto, Honshū (Shibuya, 1938). The biology of the nominotypical subspecies was studied by Enslin (1921), and summarized in Blüthgen (1961).

Parasitoids: *Chrysis* (*Tetrachrysis*) *galloisi* (?) (Hymenoptera, Chrysididae) and a tachinid fly (Diptera) (Shibuya, 1938).

Ancistrocerus melanocerus (Dalla Torre)

(Figs. 185, 194, 205, 206, 216, 223)

Ancistrocerus nigricornis Morawitz, 1889, Hor. Soc. Entomol. Ross. 23: 161 (♂)(type loc.: Kansu, China) (homonym of *Ancistrocerus nigricornis* (Curtis, 1791)).

Odynerus melanocerus Dalla Torre, 1894, Cat. Hym. 9: 78 (new name).

Ancistrocerus melanocerus: Giordani Soika, 1986, Boll. Mus. Civ. Stor. Nat. Venez. 35: 149-150.

Ancistrocerus densepilocellus Cameron, 1911, Entomologist, 44: 288 (♂)(type loc.: Japan); Sato, 1963, Nature Study, 9: 5 (in key), figs. 36, 37, 39-41; Vecht and Fischer, 1972, Hym. Cat. (n. ed.), 8: 111.

Odynerus (*Ancistrocerus*, *Euancistrocerus*) *densepilocellus*: Schulthess, 1934, Arb. Morph. Taxon. Entomol. 1: 73-74 (in key).

Japanese names: Kebuka-suji-dorobachi (Ko-suji-dorobachi; Miyama-suji-dorobachi).

Diagnosis. Body length (h+th+t1+2): 6.5-10.5 mm in ♀, 5.5-7.5 mm in ♂. Fore wing length: 7.0-10.0 mm in ♀, 6.0-8.5 mm in ♂. Closely related to *A. trifasciatus shibuyai*, from which the present species is distinguished by the following points: body more stumpy; gastral tergite 1 (measured from the transverse carina to the apical margin) 2 times as

wide as long (in *trifasciatus shibuyai* 1 2/3 times as wide as long); punctation on tergites 1 and 2 coarser; propodeal shelf narrower, often virtually absent. In the female, scutellum with two yellow spots (in the specimens from Hokkaidô, the spots often reduced or lost); basal marking on mandible much reduced or lost; tergite 3 with a yellow apical band (in the specimens from Hokkaidô the band is often reduced or lost) (Fig. 216); anterior face of fore femur apically and that of fore tibia rufous (not yellowish). In the male, apical margin of clypeus much more deeply incised (but the condition varies among individuals) (Fig. 206); scape below extensively yellow; tergite 4 and sternite 3 often with apical bands; hind tibia usually extensively yellow.

This species varies in size, structure and color pattern among individuals. Superior carina is often not developed. Female clypeus has rarely two or four yellow spots. Anterior emargination of male clypeus considerably variable in shape and depth, but constantly deeper than in *trifasciatus shibuyai*.

Material examined. Hokkaidô: 1 ♂, Sapporo, 7 vi 1938 (Y. Sugihara), 1 ♂, Ashiribetsu, 19 ix 1965 (Tamura), 1 ♀, Bibai, 20 vii 1972 (M. Taira), 1 ♂, Kiyokawa, Kamikawa-gun, 8 vii 1977 (Nosaka), 3 ♂ ♂, Muine-yama (Hôrainuma - Hütte), 8 viii 1978 (SKY), 2 ♂ ♂, Muine-yama (Hütte), 9 viii 1978 (J. Tsujii), 2 ♂ ♂, Muine-yama (top, 1400 m alt.), 8 viii 1978 (SKY), 6 ♂ ♂ 3 ♀ ♀, Teine-yama (1000 m alt.), 13 viii 1978 (SKY), 1 ♂, Soranuma-dake, 20 viii 1978 (T. Fujisawa), 2 ♂ ♂ 1 ♀, Asahigawa, 25-26 v 1979 (T. Inaoka), 1 ♀, Nukabira, 19 vii 1979 (SKY), 1 ♀, Misumai, Sapporo, 11 viii 1984 (S. Makino), 3 ♀ ♀, Tomakomai, 19 ix 1984 (I. Tateyama).

Rebun-tô: 1 ♀, 25 viii 1951 (M. Konishi).

Honshû: *Aomori-ken* - 1 ♂ 4 ♀ ♀, Otake, Hakkôda-san, 21 viii 1983 (M. Yamada), 1 ♂, Sukayu, 11 ix 1983 (M. Yamada); *Fukushima-ken* - 4 ♂ ♂ 3 ♀ ♀, Azuma-yama (1400 m alt.), 5 ix 1981 (HI); *Miyagi-ken* - 1 ♀, Aobayama, 8 v 1981 (K. Goukon), 1 ♂, Mt. Zaô, 4 vii 1979 (K. Kojima & T. Nishioka), 1 ♂ 1 ♀, same loc., 31

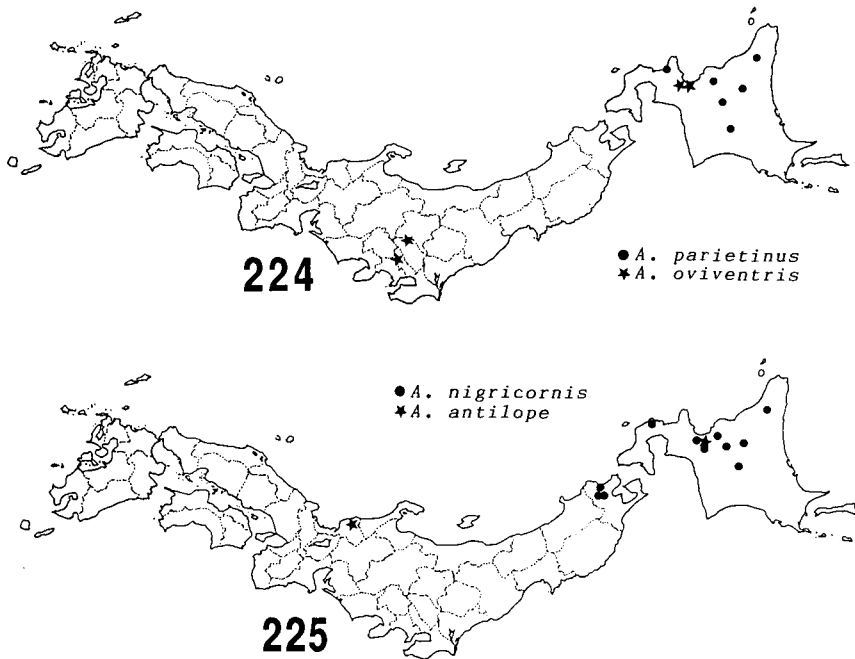

Figs. 224, 225. Distribution of Japanese *Ancistrocerus* (II).

viii - 2 ix 1979 (K. Goukon), 1 ♂, same loc., 4 ix 1980 (K. Goukon); *Niigata-ken* - 1 ♂, Myōkō, 24 viii 1962 (HI), 1 ♂, same loc., 8 viii 1967 (HI), 1 ♂, Mikuni Pass, 6 ix 1981 (KB), 1 ♀, Ojya, 18 ix 1982 (KB), 1 ♂, Seki Spa, 22 ix 1984 (KB); *Saitama-ken* - 1 ♂, Kumotori-rindō, 27 v 1972 (TN), 1 ♀, Chichibu, 24 vii 1977 (TN); *Gumma-ken* - 1 ♂, Nikkō, viii 1912 (S. Matsumura), 1 ♀, Osawa, Nikkō, 16 vii 1978 (HI), 1 ♀, Suganuma, Okunikō, 5 vii 1980 (HI); *Nagano-ken* - 2 ♂♂, Todai, Ina, 29 iv 1963 (YM), 1 ♂, same loc., 17 x 1977 (S. Aoki), 1 ♀, Tomono, Saku, 3 ix 1977 (M. Kiuchi); *Ishikawa-ken* - 1 ♂, Haku-san, 1 viii 1960 (TT), 1 ♀, same loc., 8 ix 1978 (I. Togashi), 1 ♀, same loc., 24 viii 1984 (I. Togashi); *Fukui-ken* - 1 ♀, Arashi, 18 ix 1977 (H. Kurokawa), 1 ♂, Koike, 12 viii 1979 (H. Kurokawa).

Shikoku: *Kōchi-ken* - 1 ♀, Kodakasa-yama, Kōchi-shi, 17 vii 1930 (Y. Sugihara), 1 ♀, same loc., 12 iv 1938 (Y. Sugihara), 1 ♂1 ♀, Hirooka, 22 iv 1934 (H. Okamoto). *Ehime-ken* - 1 ♂, Ishizuchi-yama, 23 vii 1935 (H. Okamoto), 6 ♂♂, Kamega-mori, 17 vii 1933 (Y. Sugihara); *Tokushima-ken* - 1 ♂, Tsurugi-san, 24 vii 1970 (TT).

Distribution. Hokkaidō; Rebun-tō; Honshū; Shikoku; Kyūshū. Korea; Mongolia.

Biology. Iwata (1938a) observed two nests in Kamikōchi (1500-1600 m in alt.), Nagano-ken (referred to as *A. densepilosellus*). Recently, Goukon (1983c, 1984, pers. comm.) made more intensive surveys on the biology of this species in Miyagi-ken, Tōhoku District. According to them, this species is bivoltine, and nests in crevices of wood and inscriptions of gravestones. In Miyagi-ken the female wasp of the fall (2nd) generation (late August to mid November) constructs cask-shaped mud cells in a mass in a depression. One to nine cells ($n=96$, $m=2.8$) are constructed, and are finally covered with mud (Goukon, 1983). Prey menu consists mainly of gelechiid larvae (Lepidoptera).

Parasitoids: an ichneumon wasp (Hymenoptera) and *Chrysis ignita*-group (Hymenoptera, Chrysididae) (Goukon, 1983c).

Ancistrocerus parietinus (Linnaeus)

(Figs. 207, 217, 224)

Vespa parietina Linnaeus, 1761, Fauna Sued. Ed. 2: 418 (type loc.: "einheimisch"[Sweden]; type destroyed).

Ancistrocerus parietinus: Thomson, 1874, Opusc. Entomol. 2: 70; Blüthgen, 1961, Faltenwespen Mitteleuropas, p. 154 (in key), 173-176; Vecht and Fischer, 1972, Hym. Cat. (n. ed.) 8: 115-116.

Japanese name: Yotsuboshi-suji-dorobachi.

Diagnosis. Female. Body length ($h+th+t1+2$): 9.0-10.5 mm. Forewing length: 9.0-10.0 mm. Structurally similar to the preceding three species, especially to *A. japonicus*. Punctuation on head and thorax finer than in *japonicus*. The apical emargination of clypeus slightly narrower; lateral teeth slightly more produced (Fig. 207). In color pattern, however, this species is very distinctive (Figs. 207, 217).

Black, with the following parts yellow: two pairs of spots on clypeus, triangular basal marking on mandible, frontal spots, short line on temple, antennal scape below, medially narrowed pronotal band, anterior and posterior spots on tegula, two spots (always isolated) on scutellum, regular apical bands on gastral tergites 1-5 (band on tergite 5 shortest, sometimes lost), a spot on tergite 6, a complete band on sternite 2, posterolateral corners of sternite 3 (this sternite rarely possesses an apical band), apical half of fore tibia anteriorly, tibiae of all legs extensively. Antennal flagellum below ferruginous. Tarsi of all legs more or less brownish.

Male unknown in Japan.

Material examined. Hokkaidō: 1 ♀, Hattaribetsu, 2 vii 1965, 1 ♀, Uryū, 5 vii 1935(?) (Okada), 2 ♀♀, Nukabira, 14 vii 1959 (TN), 1 ♀, Sōunkyō, 27 vii 1971 (TN), 1 ♀, Higashiyama, Furano, 24 vi 1974 (SKY), 1 ♀,

Osashima (date & collector not indicated).

Distribution. Hokkaidô. C. Asia to Europe.

Taxonomic notes. This may be the first record of this species from eastern Asia. Giordani Soika (1982) pointed out that *A. mongolicus* (Kostylev) from Mongolia and Korea may belong to the *A. parietinus* group.

Biology. Nesting behavior is not known in Japan. Blüthgen (1961) gives a brief account of the biology of this species in Europe. The female wasp nests in reed tubes and man-made concavities around houses. Caterpillars of microlepidopterans, and also larvae of Chrysomelidae (Coleoptera) are hunted as prey.

Ancistrocerus nigricornis (Curtis)
(Figs. 186, 191, 195, 200, 208, 209, 218, 225)

Odynerus nigricornis Curtis, 1826, Brit. Entomol. 3: 137b, no. 8 (type loc.: England).

Odynerus callosus Thomson, 1870, Opusc. Entomol. 2: 87 (type loc.: Sweden); Yasumatsu, 1938, Ins. Matsum. 13: 15 (from Sakhalin).

Ancistrocerus nigricornis: Vecht and Fischer, 1972. Hym. Cat. (n. ed.) 8: 114; Giordani Soika, 1986, Boll. Mus. Civ. Stor. Nat. Venez. 35: 152, 153.

Japanese name: Ezo-suji-dorobachi.

Diagnosis. Female. Body length (h+th+t1+2): 8.0-9.5 mm. Forewing length: 7.0-10.0 mm. Head as wide as high, densely punctate. Clypeus wider than high, strongly punctate; punctures tend to run into striae; apical emargination very shallow and its lateral teeth round (Fig. 208). Frontal keel rather sharp. Depression for cephalic foveae ill defined; foveae very small, close to each other, with reddish short hairs. Anterior ocellus as large as posterior ocellus. Temple rather developed, as seen from above wider than the superior lobe of eye. Thorax densely punctate. Pronotal carina well developed, but evanescent on the dorsal part of pronotum; frontal corners of pronotum distinctly produced. Prescutal groove ill defined; epicnemium with sparse but distinct punctures. Metanotum with a narrow anterior horizontal part, then sloping toward propodeum; metapleuron above superficially punctate, below impunctate and not shining. Propodeum without shelf; posterior face (concavity) obliquely striate, with a vertical carina; superior ridge often reduced or virtually absent; posterolateral corners produced into processes; dorsolateral face with large punctures; lateral face above with slightly smaller punctures. Punctuation on gastral tergites 1-5 much finer than on thorax, but coarser than in *japonicus*, *trifasciatus* and *melanocerus*, especially on tergites 1 and 2. Sternite 2 distinctly angulate near the base (Fig. 200), sparsely punctate; apical halves of sternites 3-5 also punctate. Last tergite and sternite impunctate.

Black, with the following parts yellow: two pairs of spots on clypeus (one located in upper portion, the other near the apex; the latter very often lost, and clypeus rarely wholly black)(Fig. 208), frontal spot, antennal scape below, spot on mandibular base (often lost), small spot on temple, medially narrowed pronotal band that does not extend to the lateral part of pronotum, anterior and posterior spots on tegula, small spot on dorsal mesepisternum, a pair of small spots on scutellum, apical band on gastral tergite 1 (often laterally dilated), wider and regular apical band on tergite 2, narrower apical bands on tergites 3 and 4 (Fig. 218), sinuated apical bands on sternites 2 and 3, posterolateral corners of sternite 4 (often lost), apical half of fore femur anteriorly, tibiae of all legs

extensively. Mandible blackish brown, apically rufous. Antennal flagellum ferruginous below. Coxae and femora largely black; tarsi brownish, sometimes partly tinged with yellow.

Male. Body length (h+th+t1+2): 6.0-7.0 mm. Forewing length: 6.0-7.5 mm. Differs from the female in the following points: clypeus slightly higher than wide (when excluding lateral lobes)(Fig. 209), wholly yellow; front corners of pronotum more acutely produced (Figs. 195 vs. 196); supraclypeal area with a yellow line along eye; mandible largely yellow; scutellum wholly black; fore and mid coxae and fore and mid femora yellow on anterior face; tarsi extensively yellowish. Antennal hook medium-sized, apically rather pointed (Fig. 186).

Material examined: Hokkaidô: 1 ♀, Maruyama, Sapporo, 7 v 1906, 1 ♀, Sapporo, 26 v 1908 (S. Matsumura), 1 ♀, Jôzankei, 18 v 1910 (S. Matsumura), 1 ♀, Sapporo, 25 v 1910 (S. Matsumura), 1 ♀, Jôzankei, 18 v 1910 (S. Matsumura), 1 ♀, Moiwa, Sapporo, 13 vi 1911 (S. Matsumura), 1 ♀, same loc., 20 vi 1912 (S. Matsumura), 1 ♀, Jôzankei, 3 vii 1912 (S. Matsumura), 1 ♂, Sapporo, 14 x 1917 (S. Matsumura), 1 ♂, Tokachidake, 1 viii 1939 (T. Sawamoto), 1 ♀, Jôzankei, 5 vi 1938 (Y. Sugihara), 1 ♀, Sapporo, 25 viii 1935 (Y. Sugihara), 1 ♀, Maruyama, Sapporo, 15 ix 1929 (C. Watanabe), 1 ♀, same loc., 18 v 1930 (T. Uchida), 2 ♀ ♀, Uryû, 5 vii 1935 (Okada), 1 ♀, Sapporo, 21 vii 1943 (S.F. Sakagami), 1 ♀, same loc., 4 v 1947 (S.F. Sakagami), 1 ♀, Maruyama, Sapporo, 25 ix 1955 (K. Kamijo), 1 ♀, Jûgoshima, Sapporo, 29 x 1962 (SKY), 1 ♀, Miyanomori, Sapporo, 30 v 1965 (SY), 1 ♀, Heiwa, Sapporo, 27 v 1967 (K. Hoshii), 1 ♀, Bibai, 29 v 1972 (M. Taira), 1 ♂, Jôzankei, 9 ix 1972 (YH), 1 ♀, Hôheikyô, Sapporo, 23 v 1973 (T. Okazawa), 2 ♀ ♀, Hakken-zan, Sapporo, 11 v 1975 (H. Taoka), 1 ♀, same loc., 23 v 1976 (H. Taoka), 1 ♀, Moiwa, Sapporo, 10 v 1977 (T. Kumata), 1 ♀, same loc., 8 vi 1979 (I. Yasui), 2 ♀ ♀, Kôshunai, Bibai, 6-8 vi 1978 (SKY), 2 ♀ ♀, Mizuho, Higashi-asahigawa, 15-19 v 1978 (SKY), 1 ♀, Moiwa, Sapporo, 23 iv 1978 (M. Mori), 2 ♀ ♀, Toyotaki, Sapporo, 24 v 1978 (SKY), 1 ♀, Hakken-zan, Sapporo, 24 vi 1978 (SKY), 4 ♂ ♂ 2 ♀ ♀, Heiwano-taki, Sapporo, 23 ix 1978 (SKY), 3 ♀ ♀, Takisato, 10 v 1979 (H. Fukuda), 1 ♀, Toyotaki, Sapporo, 30 v 1979 (T. Fujisawa), 2 ♀ ♀, Asahigawa, 3-4 vi 1979 (T. Inaoka), 3 ♀ ♀, Toyotaki, Sapporo, 30 v - 8 vi 1979 (SKY), 1 ♀, Kariba-dake, 14 vii 1979 (T. Fujisawa), 1 ♀, Furano, 13 vi 1979 (H. Fukuda), 1 ♀, Otarunai, vii 1979 (T. Fujisawa), 1 ♀, Asahigaoka, Sapporo, 17 ix 1979 (SKY), 1 ♀, Toyotaki, Sapporo, 30 v 1980 (SKY), 1 ♀, same loc., 21 vi 1980 (S. Makino), 1 ♀, Misumai, Sapporo, 23 viii 1983 (S. Makino), 2 ♂ ♂, same loc., 11 ix 1983 (S. Makino), 1 ♀, Toyotaki, Sapporo, 7 vi 1986 (S. Makino), 2 ♀ ♀, Nishino, Sapporo, 5 vii 1986 (U. Kurosu), 1 ♀, Maruyama, Sapporo, 11 vi 1986 (M. Sato).

Honshû: *Aomori-ken* - 1 ♀, Kuroishi, 3 v 1935 (I. Tateyama), 1 ♀, Yamagata, 31 v 1936 (I. Tateyama).

Distribution. Hokkaidô; Honshû (Tôhoku District). Sakhalin; Europe.

Biology. No information is available for the Japanese population. According to the collection data, this species seems to have at least two generations, but males are collected only in August - October.

In central Europe, the second generation females of this species are known to hibernate and appear in early spring next year, then prepare their nests that produce both sexes in June to mid-July (1st generation); the females of the first generation again build nests that produce both sexes (mid-August to September), then inseminated females overwinter. The female wasp nests in pre-existing cavities in wood, stones and metal, and hollow plant stems (Nielsen, 1932, referred to as *A. callosus*; summarized in Blüthgen, 1961).

Ancistrocerus oviventris oviventris (Wesmael)

(Figs. 187, 189, 190, 197, 210, 211, 219, 224)

Odynerus oviventris Wesmael, 1836, Bull. Acad. R. Belg. 3: 45, pl. 2, fig. 1 (♀ ♂)(type loc.: Bruxelles, Belgium).

Ancistrocerus oviventris oviventris: Blüthgen, 1961, Faltenwespen Mitteleuropas, pp. 179-180; Vecht and

Fischer, 1972, Hym. Cat. (n. ed.) 8: 115.

Ancistrocerus yamanei Giordani Soika, 1986, Boll. Mus. Civ. Stor. Nat. Venezia, 35: 148-149, fig. 45 (♀)
(type loc.: Tôkyô). Syn. nov.

Japanese name: Kenaga-suji-dorobachi.

Diagnosis. Female. Body length (h+th+t1+2): 9.5-10.0 mm. Forewing length: 9.0-10.0 mm. Head and alitrunk with long and dense hairs; hairs on vertex distinctly longer than the distance between the posterior ocelli; antennal scape, especially near the base, with many long hairs (Fig. 189); gastral tergites 1-5 with long hairs. Head slightly wider than high. Punctures on frons and eye sinus relatively small, but very dense; punctation on gena much sparser. Clypeus much wider than high, with sparse punctation, somewhat shining, apically narrowly but relatively deeply emarginate; lateral teeth of this emargination round (Fig. 210). Distance between the posterior ocelli distinctly shorter than that between posterior ocellus and eye. Depression for cephalic foveae ill defined; foveae very small and close to each other. Temple well developed, as seen from above, much wider than the superior lobe of eye. Thorax stumpy, densely punctate. Punctation on lateral face of pronotum irregular in shape, and spaces between punctures running into irregular carinae in lower portion of this part. Prescotal grooves almost invisible. Punctures on mesopleuron larger than on mesoscutum, ill defined; interspaces running into carinae. Metanotum with a flat anterior part that is slightly elevated above the level of the posterior part of scutellum; metapleuron posteriorly not demarcated by a suture from propodeum, superficially striate above, smooth but dull below. Propodeum without shelf, with a vertical part between metanotum and superior ridge. Propodeal concavity very weakly and obliquely carinate, with a complete median keel; superior ridge often much reduced, especially in mesal part; inferior ridge developed, with distinct posterolateral angle. Dorsolateral part of propodeum without distinct punctures; lateral ridge not developed; lateral face almost impunctate and dull, in upper portion with weak carinae. Punctures on gastral tergite 1 relatively large, but ill defined and interspaces often larger than punctures; punctation on other tergites much finer and sparser. Punctation on sternite 2 fine and sparse; that on the apical half of other sternites slightly coarser.

Black; yellow are: two pairs of spots on clypeus (upper two are large and lower two small; all are lost in the specimens from Hokkaidô), triangular marking on mandibular base, minute spot on each temple, frontal spot, narrow pronotal band (only slightly dilated laterally), an outer band on tegula, a transverse marking on scutellum (narrowly interrupted in the middle), regular apical bands on tergites 1-5 (Fig. 219), apical margins of sternites 1 and 2, posterolateral corners of sternites 3 and 4 (in the specimens from Honshû, also sternite 3 with apical band), spot on tergite 6, apical part of fore femur anteriorly, tibiae of all legs extensively. Antenna almost wholly black. Tarsi of all legs brownish.

Male. Body length (h+th+t1+2): 7.5-9.0 mm. Fore wing length: 7.0-8.5 mm. Much as in the female from which it differs in the following points: clypeus very deeply emarginate at apex; lateral teeth of the emargination long and sharp (Fig. 211); inner margin of mandible with a large concavity in the middle (Fig. 190); front corner of pronotum produced into a process (Fig. 197); clypeus, labrum and mandible largely yellow; antennal scape below yellow; frontal spot smaller; scutellum without yellow; last tergite without yellow spot; apical parts of femora of all legs, tibiae of all legs almost wholly yellow; tarsi also marked with yellow; 2-3 terminal segments of antenna ferruginous. Antennal hook with the apex

almost reaching the base of segment 11 (Fig. 187).

Material examined. Hokkaidô: 1 ♀, Sapporo (date and collector not indicated), 1 ♀, Jôzankei, 24 vi 1951 (K. Kamiyo), 1 ♀, Hakken-zan, Sapporo, 24 vi 1978 (SKY), 1 ♂, Toyotaki, Sapporo, 30 v 1979 (SKY), 1 ♂, same loc., 7 vi 1986 (S. Makino).

Honshû: *Tôkyô-to* - 1 ♀, Kobotoke, Minamitama, 29 iv 1950 (K. Harada) (holotype of *A. yamanei*); *Saitama-ken* - 1 ♀, Kodama, 22 iv 1965 (TN), 2 ♀ ♀, same loc., 8 v 1965 (TN).

Distribution. Hokkaidô; Honshû (Kantô District). Eastern Asia to central and northern Europe.

Taxonomic notes. This rare species is easily distinguished from other Japanese congeners by the long body hairs, widely and deeply emarginate clypeal apex in the male, median concavity on inner margin of male mandible, etc. There are constant differences in color pattern between the populations of Hokkaidô and Honshû. In the specimens from Hokkaidô, clypeus wholly black and sternite 3 without yellow apical band, while those from Honshû have the clypeus with four yellow markings and the sternite 3 with a yellow apical band.

I have examined the holotype (♀) of *A. yamanei* through the courtesy of Dr. Giordani Soika. It was compared with *A. parietinus* by him to show constant differences (Giordani Soika, 1986), but actually it well agrees with *A. oviventris*.

Biology. Nothing is known of the nesting biology of this species in Japan. In Europe, this wasp is univoltine and constructs its mud nests on depressions of stones, etc.; the nest often consists of more than ten cells in a mass (Nielsen, 1932). The female wasp hunts for caterpillars of Microlepidoptera; some authors reported the larvae of snout beetles and leaf beetles as prey of this wasp (see Blüthgen, 1961).

Ancistrocerus antilope antilope (Panzer)

(Figs. 188, 198, 212, 213, 220, 225)

Vespa antilope Panzer, 1798, Fauna Ins. Germ. 5(53): 9, tav. 9 (♀)(type loc.: Austria).

Ancistrocerus antilope: Blüthgen, 1943, Stett. Ent. Ztg. 104: 156; Yasumatsu, 1938, Ins. Matsum. 13: 15; Vecht and Fischer, 1972, Hym. Cat. (n. ed.) 8: 108-109; Giordani Soika, 1986, Boll. Mus. Civ. Stor. Nat. Venez. 35: 152.

Japanese name: Tsuya-suji-dorobachi.

Diagnosis. Female. Body length (h+th+t1+2): 10.5-11.5 mm. Fore wing length: 11.0-11.5 mm. Head nearly as wide as high, densely punctate on frons and sinus of eye; punctation on gena sparser. Clypeus much wider than high, narrowly and shallowly emarginate at apex (Fig. 212), sparsely punctate. Distance between the posterior ocelli shorter than that between posterior ocellus and eye. Temple rather developed, much wider than the superior lobe of eye. Depression for cephalic foveae large but ill defined; foveae small, close to each other. Thorax moderately punctate; spaces between punctures shining. Prescutal grooves visible. Punctation on ventral mesepisternum sparse; dorsal mesepisternum posteriorly and mesepimeron irregularly striate. Metapleuron not clearly separated from propodeum by a suture, almost impunctate, with glaring luster. Propodeum virtually without shelf. Propodeal concavity irregularly and obliquely striate, with a median keel; superior ridge present but less developed than inferior ridge. Dorsolateral face of propodeum irregularly reticulate; lateral ridge present; lateral face smooth and shining below, irregularly striate above. Horizontal part of gastral tergite 1

moderately punctate; tergite 2 with very fine punctures apically; tergites 3-5 with slightly larger and ill-defined punctures in apical half; tergite 6 with a preapical depression, with ill-defined punctures around it. Punctuation on sternites finer than on tergites.

Black, the following parts yellow: a pair of longitudinal markings on clypeus near its base (in the specimens from Hokkaidô, these are much reduced), small frontal spot, minute spot on temple, basal marking on mandible, antennal scape below, a pair of triangle markings on pronotum anteriorly, regular bands on gastral tergites 1-3 and sternite 2, small spot on last tergite (Fig. 220), posterolateral corners of sternite 3, apical part of fore femur anteriorly, anterior faces of tibiae of all legs. Tarsi reddish or blackish brown. Antennal flagellum below ferruginous.

Male. Body length (h+th+t1+2): ca. 10 mm. Fore wing length: ca. 10 mm. The male differs from the female as follows: head wider than high; clypeus nearly as wide as high; front corners of pronotum bluntly produced (Fig. 198); mesopleuron much more coarsely punctate; scutellum with a longitudinal median groove; lateral ridge of propodeum much more developed so as to form a wing; clypeus and mandible largely yellow; frontal spot absent; antennal flagellum orange yellow below; tergite 4 with a narrow apical band; sternite 3 with an apical band; mid and hind coxae and mid femur with yellow; tibiae more extensively yellow. Antennal hook very small; its apex not reaching the middle of segment 11 (Fig. 188).

Material examined. Hokkaidô: 1 ♀, Moiwa, Sapporo, 23 vi 1932 (T. Uchida).

Honshû: *Fukui-ken* - 1 ♂ 2 ♀, Ashuma, Fukui-shi, 10-21 v 1959 (TT).

Distribution. Hokkaidô; Honshû. Holarctic. Among the Eumenidae, this is the only Japanese species that is Holarctic in distribution.

Biology. Nesting biology is not known in Japan. In Europe and North America, this wasp is univoltine and nests in deserted mud cells of other wasps, tunnels dug in wood by larvae of longicorn beetles and wood wasps, and also in reed tubes (Blüthgen, 1961). This species has a quite wide prey range: caterpillars of lepidopterous families Oecophoridae, Gelechiidae, Olethreutidae, Tortricidae, Pyralidae, Noctuidae (Krombein, 1979), and Hesperidae (Blüthgen, 1961); larvae of *Nematus ericksoni* (Hymenoptera, Tenthredinidae) (Ashmead, 1894); larvae of leaf beetles (Coleoptera, Chrysomelidae) (in Finland; cf. Blüthgen, 1961). Krombein listed parasitoids found in nests of this species in North America.

Genus *Symmorphus* Wesmael

Symmorphus Wesmael, 1836, Bull. Acad. R. Belg. 3: 45 (subgenus of *Odynerus* Latreille) (type species: *Odynerus elegans* Wesmael, 1833, designated by Richards, 1935); Dalla Torre, 1904, Gen. Ins. 19: 35, 36 (subgenus of *Odynerus* Latreille).

Protodynerus Saussure, 1855, Et. Fam. Vesp. 3: 184, 186, 352 (new name for *Symmorphus* Wesmael).

Japanese names: Hamushi-dorobachi Zoku (Hoso-dorobachi Zoku).

Body usually slender; but some large species such as *S. captivus* and others resemble wasps of *Ancistrocerus* in body shape. Female clypeus usually wider than high, apically narrowly emarginate (in *S. decens* widely truncate), with more or less acute lateral teeth. Male antenna with the terminal segment of normal shape (not forming a recurved hook). Thorax usually duplipunctate, i.e., with macropunctures of normal type and micropunctures. Mesoscutum with distinct notaulices. Epicnemial carina usually present (absent in

S. foveolatus). Propodeum often with a shelf behind metanotum; the shelf medially with a pit of varying size. Gastral segment 1 distinctly narrower than segment 2, but not petiolate. Tergite 1 strongly punctate on posterior horizontal disc, with a transverse carina at the basal border of the disc; the disc also with a longitudinal furrow; anterior face of the tergite sometimes with a short median carina. Tergites 2-6(7) usually impunctate or only weakly punctate.

Most species of this genus hunt chrysomelid larvae (Coleoptera) for their young. But at least three species (including one Japanese species) hunt only larvae of Curculionidae, and some species only small lepidopterous larvae. The Nearctic *S. canadensis* (Sauss.) hunts larvae of various coleopteran families (Iwata, 1971). The biology of the Japanese species should be entirely resurveyed, because the taxonomy of these wasps had been quite confused and only two species had been recognized until Giordani Soika (1975) published a revision.

Key to the Japanese species

An excellent key to the Japanese species was given by Giordani Soika (1975) who recognized seven species (the key was translated into Japanese by Tsuneki, 1976). Tsuneki (1977, 1986) added two new species and one new subspecies of *S. mutinensis* to the fauna of Japan, and I have found three additional forms which will be described as new species below. In Japan this genus contains several closely related species which are very difficult to separate. Here, a practical key using mainly color pattern is presented. It is strongly advised to use this key together with Giordani Soika's that refers more frequently to structural characters but does not include all the forms dealt with in the present paper. In the following key the punctuation concerns macropunctuation alone.

1. Epicnemial carina absent. Gastral tergite 1, seen from above, longer than wide at its apical margin. *S. foveolatus* Gus.
- Epicnemial carina present. Gastral tergite 1, seen from above, as long as or shorter than wide 2
2. Clypeus widely truncate apically. Mesopleuron densely and uniformly punctate. Tergites 1, 2, (3), 4, 5 each with a yellow apical band (♀). *S. decens* (Kost.)
- Clypeus narrowly emarginate apically. Punctuation on mesopleuron various, but in most species weaker and sparser. Tergite 5 without yellow band (♀). 3
3. Large species; h+th+t1+2: 12-13 mm in ♀, 9-10 mm in ♂. Body shape of *Ancistrocerus*-type. 4
- Smaller species; h+th+t1+2: less than 9 mm in ♀, usually less than 7 mm in ♂. Body much more slender. Female clypeus wholly black. Ventral mesepisternum impunctate or only weakly and sparsely punctate (rather strongly punctate in *S. iwatai*)..... 5
4. Clypeus with a basal yellow marking (♀). Antennal scape and flagellum wholly blackish (♀). *S. captivus* (Sm.)
- Clypeus wholly black (♀). Antennal scape and flagellum ferruginous yellow below (♀). *S. sounkionis* Tsuneki
5. Antenna 13-segmented. Gaster with 7 visible segments. Males 6
- Antenna 12-segmented. Gaster with 6 visible segments. Females 13
6. Antennal scape with a yellow spot or stripe. If wholly black, apical segments of

- antenna below largely ferruginous. 7
- Antennal scape wholly blackish. 9
7. Clypeus basally yellow. Pronotum anteriorly with a pair of large triangular yellow markings. Tergite 3 with a yellow apical band. Apical lamella of tergite 1 medially produced backward. *S. tsushmanus* sp. nov.
- Clypeus nearly wholly yellow. Pronotum wholly black, at most with a pair of very minute orange spots. Tergite 3 without yellow band. Apical lamella of tergite 1 normal. 8
8. Apical segments of antenna much thickened; undersides of these segments extensively ferruginous. Mandible largely yellow. *S. apiciornatus* (Cam.)
- Apical segments of antenna moderately thickened, with ferruginous stripes below. Mandible at most with a small yellow marking. *S. carinatus* sp. nov.
9. Clypeus nearly wholly yellow. Pronotum with a pair of yellow spots. Metapleuron and lateral face of propodeum finely striate. *S. iwatai* sp. nov.
- Clypeus wholly black or with an irregular yellow marking. Pronotum without yellow marking. Metapleuron and lateral face of propodeum more coarsely striate or strongly punctate. 10
10. Mesopleuron strongly punctate. Mesepimeron reticulate. Scutellum with large macropunctures. *S. mutinensis* (Bald.)
- Mesopleuron shining, at most finely and sparsely punctate. Mesepimeron not reticulate. Punctures on scutellum much smaller. 11
11. Posterior part of metanotum transversely striate or corrugated. Transverse carina on tergite 1 not incised medially. Mesoscutum very finely and sparsely punctate. Propodeal pit very large. *S. mizuhonis* Tsuneki
- Posterior part of metanotum not striate. Transverse carina on tergite 1 incised medially. 12
12. Mesoscutum and metanotum rather strongly punctate. Dorsal mesepisternum with punctures. Propodeal pit very small. *S. cliens* G.S.
- Mesoscutum and metanotum with much finer punctation. Dorsal mesepisternum impunctate. Propodeal pit large. *S. ishikawai* G.S.
13. Cephalic foveae as large as ocelli. Mesoscutum with very sparse and superficial punctation. Mesosoma wholly black. Tergites 1 and 2 with yellow apical bands. *S. ishikawai* G.S.
- Cephalic foveae distinctly smaller than ocelli. 14
14. Propodeal shelf very narrow and indistinct; median pit inconspicuous. Metapleuron, and lateral and posterior face of propodeum finely striate, usually without luster. Posterior half of metanotum dull. Mesosoma wholly black. *S. apiciornatus* (Cam.)
- Propodeum with a distinct (but sometimes slightly sloping) shelf, which has usually a large median pit (in *cliens* the pit is often a narrow slit). 15
15. Dorsal mesepisternum with large punctures. Mesepimeron strongly punctate or reticulate. Mesoscutum often with a pair of yellow spots. *S. mutinensis* (Bald.)
- Dorsal mesepisternum and mesepimeron at most with small punctures sparsely. Mesoscutum always wholly black. 16
16. Posterior part of mesopleuron, metapleuron wholly, and lateral face of propodeum microscopically striate or shagreened, dull. Pronotum anteriorly with a pair of yellow spots. Anterior vertical face of tergite 1 with a strong vertical carina. *S. carinatus* sp. nov.

- Posterior part of mesopleuron, metapleuron and lateral face of propodeum at least partly shining; striation, if any, much coarser. Pronotum entirely black. Anterior vertical face of tergite 1 without carina. 17
- 17. Median pit on propodeal shelf large and round. Cephalic foveae very small. Dorsal mesepisternum often with a yellow spot. Transverse carina on tergite 1 not incised medially. Tergite 4 without yellow apical band. *S. mizuhonis* Tsuneki
- Median pit small and often narrow. Cephalic foveae larger, more than half as large as posterior ocelli in diameter. Thorax usually wholly black. Transverse carina on tergite 1 medially incised. Tergite 4 often with an incomplete yellow apical band..... *S. cliens* G.S.

Symmorphus foveolatus Gussakowskij
(Figs. 226, 227, 236, 246, 256, 277)

Symmorphus foveolatus Gussakowskij, 1933, Ark. Zool. 24 A (10): 55 (♀) (type loc.: Ussuri); Giordani Soika, 1963, Boll. Soc. Entomol. Ital. 93: 124; 1975, Boll. Mus. Civ. Venez. 27: 149 (in key), 153; Vecht and Fischer, 1972, Hym. Cat. (n. ed.), 8: 121.

Odynerus (Symmorphus) captivus: Yasumatsu, 1938, Fukuoka Hakub. Zasshi, 2: 11, tab. 3, figs. 1-5 (part?); 1950, Icon. Ins. Jpn. 2nd ed. p. 1457, fig. 4203 (part?) (misidentification).

Japanese names: Haranaga-hamushi-dorobachi (Sumisu-hamushi-dorobachi).

Diagnosis. Female. Body length (h+th+t1+2): 7.0-10.5 mm. Fore wing length: 7.5-10.0 mm. Head nearly circular in frontal view; macropunctures on frons not very dense, smaller than interspaces; punctuation on gena and vertex much finer and sparser. Cephalic foveae slightly smaller than posterior ocelli, each situated in a depression; the depressions not connected to each other by a furrow. Clypeus distinctly wider than high, very finely punctate, narrowly and shallowly emarginate at apex (Fig. 226). Interantennal area roundly swollen, with a Y-shaped carina which is often obscure. Distance between the posterior ocelli slightly shorter than that between posterior ocellus and eye (9:10). Flagellar segment 1 of antenna slightly longer than wide at its apex. Thorax with macropunctures that are usually as large as or smaller than interspaces which are shining. Front corners of pronotum round. Mesoscutum with complete notaulices; parapsidal lines very weak; median scutal line visible only in anterior third. Scutellum with a weak median furrow. Mesopleuron without epicnemial carina (this condition is seen only in this species among the Japanese species). Metanotum with large macropunctures, impunctate and dull in its posterior 1/4 to 1/3; metapleuron above with a few macropunctures, below micropunctate and without macropunctures. Dorsolateral parts of propodeum with large and dense macropunctures; propodeal shelf narrow, sloping posteriorly, with a large median pit (Fig. 256); propodeal concavity with fine and dense striae running obliquely, and with a complete median vertical carina. Lateral face of propodeum macropunctate (punctuation often superficial); spaces between punctures micropunctate and with inconspicuous striae. Superior and inferior ridges of propodeum poorly developed, often almost absent. Gastral tergite 1 seen from above longer than wide at its apex, gradually widened toward apex, strongly punctate, apically slightly duplicate, with a preapical swelling; each lateral end of the swelling bearing a short carina running toward the base of the tergite but not connected with the transverse carina, which is not sharply defined and not incised in the middle; anterior face of tergite 1 coarsely and irregularly punctate. Tergite 2 shining, weakly punctate at base; other tergites almost impunctate. Sternite 1

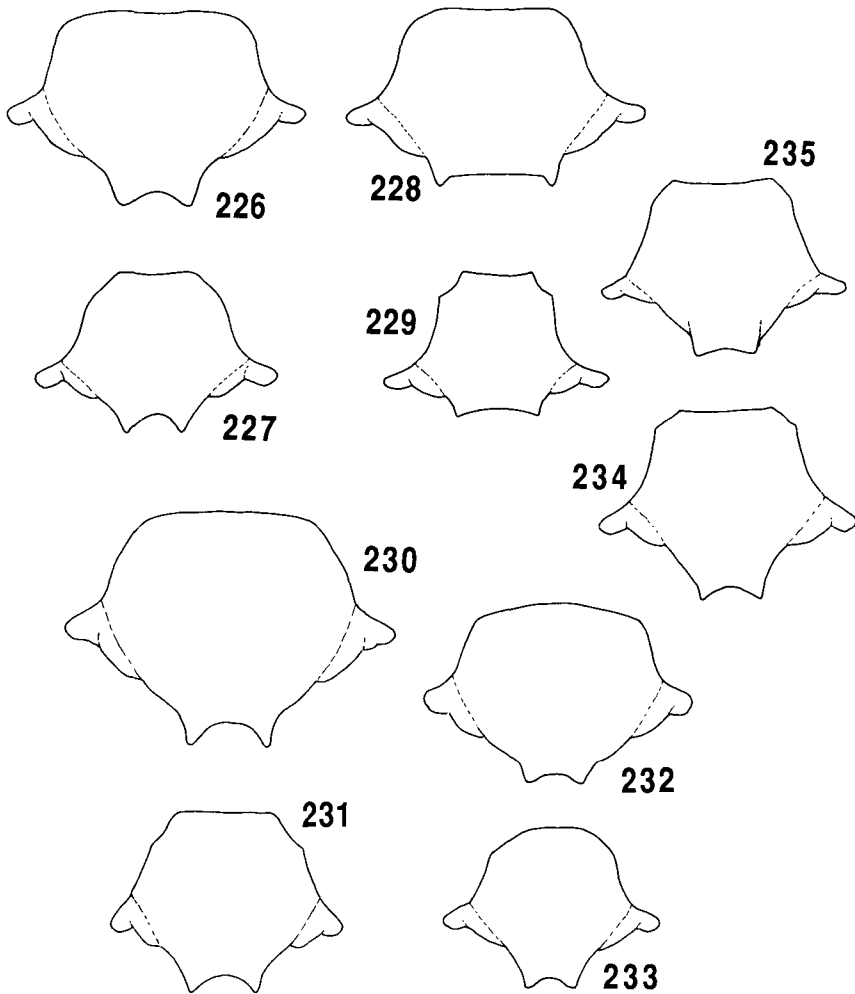

Figs. 226-235. Clypeus of Japanese *Symmorphus*. 226, *foveolatus* ♀; 227, ditto ♂; 228, *decens* ♀; 229, ditto ♂; 230, *captivus* ♀; 231, ditto ♂; 232, *carinatus* ♀; 233, ditto ♂; 234, *iwatai* ♂; 235, *tsushimaensis* ♂.

irregularly and strongly reticulate; sternites 2-6 almost impunctate.

Black, with the following parts yellow: two small frontal spots (sometimes connected to form a single spot, or completely lost), a minute spot on temple, an apical band on tergite 1 medially dilated and at the middle incised, apical bands on tergites 2, 4 and sternite 2 (the band on sternite 2 sinuated or medially interrupted), anterior face of fore (rarely also mid) tibia. Mandible ferruginous in apical 1/3. Antennal flagellum below and legs slightly brownish.

Male. Body length (h+th+t1+2): 7.5-8.0 mm. Fore wing length: 7.5-8.0 mm. Clypeus more deeply emarginate at apex than in the female (Fig. 227; lateral angles of the emargination acute), almost wholly yellow. Yellow frontal marking completely lost. Dorsal

mesepisternum sometimes with a small yellow spot. Apical band on tergite 1 narrower and more regular than in the female; tergite 5 also with an apical band. Tibiae of all legs extensively yellowish. Flagellum almost wholly black, without distinct tyloids; last segment longer than wide at its base, as long as the preceding segment (Fig. 236).

Material examined. Hokkaidô: 1 ♂, Garugawa, 22 vi 1922 (H. Kôno), 1 ♂, same loc., 8 vi 1925 (H. Kôno), 1 ♀, Sapporo, 1 vii 1955 (K. Kamijo), 1 ♀, same loc., 3 vii 1965 (T. Kocho), 1 ♀, Gamushi, 12 vii 1958, 1 ♀, Otarunai (Helvetien Hütte), 26 vii 1965 (SY), 1 ♀, Shikotsu-ko, 17 vii 1977 (SKY), 1 ♀, Mt. Teine (7-800 m alt.), 13 viii 1978 (SKY).

Honshû: *Aomori-ken* - 1 ♀, Osore-zan, 12 viii 1979 (K. Goukon); *Yamagata-ken* - 1 ♀, Oguni, 25 vi 1980 (HI), 1 ♀, Nan'yô, 13 vii 1980 (HI); *Miyagi-ken* - 1 ♂, Rifu, 29 v 1983 (K. Goukon), 1 ♂, Tagajô, 4 vi 1983 (K. Goukon); *Niigata-ken* - 1 ♀, Numa, Sekikawa, 10 vii 1966 (HI), 6 ♀ ♀, Shibata, 12 vii 1981 (HI); *Nagano-ken* - 1 ♀, Komaga-take, Ina, 10 viii 1962 (K. Oshima); *Saitama-ken* - 1 ♀, Izuga-dake, 3 vii 1984 (S. Aoki); *Tôkyô-to* - 1 ♂ (S. Hirayama); *Fukui-ken* - 1 ♀, Hatogayu, 15 vii 1956 (K. Iwata).

Shikoku: *Kôchi-ken* - 1 ♀, Kodakasa-yama, Kôchi-shi, 6 v 1930 (Y. Sugihara), 1 ♀, same loc., 5 vii 1931 (Y. Sugihara), 1 ♀, Mt. Washio, 14 v 1933 (Y. Sugihara).

Distribution. Hokkaidô; Honshû; Shikoku; Kyûshû. E. Siberia. Yasumatsu (1938a) recorded "*Odynerus captivus*" also from Korea.

Taxonomic notes. Yasumatsu's (1938a) material contained very small males with fore wing 6.0 mm in length. I have never seen such a small specimen of this species. It is quite possible that there were included males of some other species in his material.

Biology. Iwata (1938b) reported the biology of "*Odynerus captivus*". Yasumatsu's (1938a) material contained several specimens of "*O. captivus*" collected by Iwata in Settsu (Osaka). The wasp studied by Iwata and identified by K. Yasumatsu was most probably *S. foveolatus* as pointed out by Giordani Soika (1975). Here I summarize Iwata's account on the biology of "*O. captivus*". The wasp flies from May to July, and has only one generation in a year. The female nests in wheat straws and slender tubes of bamboo and reed which are bundled to make roofs and blinds. Rarely deserted beetle burrows in wood may be utilized. The nest consists of 1 to 6 brood cells (usually 1-3; the cell measures 21 to 45 mm in length and 3 to 6 mm in width), and 1 to 3 empty cells. Cell partitions (0.5-1.0 mm thick) and entrance plug (2-5 mm thick) are made of mud. Brood cells are each provisioned with 4-31 beetle larvae (4-8 mm long); the number of beetle larvae stored in a cell depends on their body size. In Ôsaka the full-grown larvae of two chrysomelids, *Gastroidea atrocyanea* on *Rumex* and *Plagioderia versicola* on *Salix*, are mainly captured. Additional accounts on the nesting biology of this species are given in Iwata (1978b) and Tsuneki (1973a).

Parasitoids: *Chrysis galloisi* and *C. sarafschana rubripyga* (Hymenoptera, Chrysididae) (Tsuneki, 1973a).

Symmorphus decens (Kostylev)
(Figs. 228, 229, 237, 247, 257, 278)

Odynerus decens Kostylev, 1940, Bull. Soc. Nat. Moscou, Sect. Biol. NS, 49 (5/6): 40 (♀) (type loc.: Minoo, Osaka).

Odynerus apiciornatus: Yasumatsu, 1938, Fukuoka Hakub. Zasshi, 2: 111, 114, tab. 3, figs. 6-9.

Symmorphus decens: Giordani Soika, 1975, Boll. Mus. Civ. Venezia, 27: 154-156, figs. 12, 13.

Japanese names: Kuchibiro-hamushi-dorobachi (Yamato-hamushi-dorobachi).

Diagnosis. Female. Body length (h+th+t1+2): 7.0-9.5 mm. Fore wing length: 8.5-10.5 mm. Head wider than high, densely macropunctate; punctures relatively small. Cephalic

foveae quite small, each located in an elliptical depression; the depressions not connected to each other. Clypeus much wider than high, apically very broadly truncate; each lateral end of the truncated margin with a small but distinct denticle (Fig. 228). Distance between the posterior ocelli as long as ocello-ocular distance. Flagellar segment 1 more than 1.5 times as long as wide at its apex. Thorax very densely macropunctate except on pronotal tubercle and in anterior and posterior parts of mesopleuron. Front corners of pronotum round. Notaulices complete, but narrow; parapsidal lines still narrower; median scutal line visible only in anterior third. Epicnemial carina visible only in its lower part. Macropunctuation on metanotum coarser than on scutellum; posterior portion of metanotum with vertical carinae; metapleuron impunctate, finely striate above. Propodeal shelf almost absent, with a pit just behind metanotum (Fig. 257). Dorsal face of propodeum coarsely punctate or reticulate; concavity with a complete median carina, without striae; inferior ridge visible; superior ridge almost absent; lateral portion of propodeum macropunctate and striate above. Gastral tergite 1 nearly as long as wide at its apex; anterior face with a few ill-defined macropunctures, without vertical carina; transverse carina rather sharply defined, not incised in the middle; posterior horizontal part distinctly punctate. Tergites 2-6 finely and superficially punctate. Sternite 1 with a strong median carina and irregularly running carinae; punctuation on sternites much finer than on tergites.

Black, with the following parts yellow: a spot on the base of antennal scape anteriorly (often reduced), minute spot on temple, a pair of small markings on pronotum anteriorly, apical bands on gastral tergites 1, 2, 4, 5 (band on tergite 2 widest), apical band on sternite 2 medially interrupted, and anterior face of fore tibia.

Male. Body length (h+th+t1+2): 6.0-8.5 mm. Fore wing length: 7.0-8.0 mm. Similar to

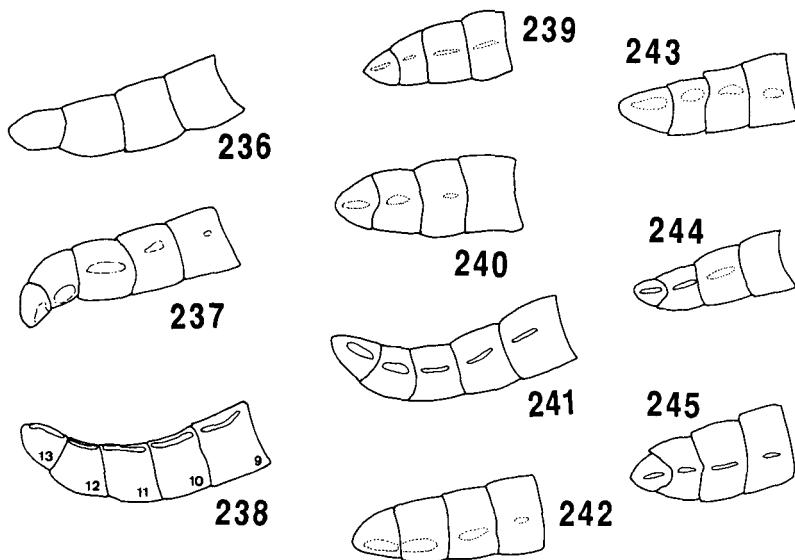

Figs. 236-245. Apical segments of male antenna in Japanese *Symmorphus*. 236, *foveolatus*; 237, *decens*; 238, *captivus*; 239, *apiciornatus*; 240, *carinatus*; 241, *iwatai*; 242, *tsushimanus*; 243, *mutinensis*; 244, *mizuhonis*; 245, *diens*.

the female in structure and coloration, with the following differences: clypeus largely and anterior face of mandible in basal 2/3 yellow; yellow marking on antennal scape larger; 4-5 terminal segments of antenna more or less extensively orange yellow; pronotal spots often lost; tergite 6 with an apical band; sternite 3 sometimes with yellow spots apically; fore and mid tibia anteriorly and tarsi of all legs extensively yellowish. Antennal segments 10-13 with ill-defined tyloids; last segment small, as long as wide at its base and shorter than segment 12 (Fig. 237).

Material examined. Honshû: *Tôkyô-to* - 1 ♂, Kobotoke-tôge, 22 v 1946 (S.F. Sakagami); *Ishikawa-ken* - 1 ♂, Yoshioka, Kamachi, 14 v 1974 (I. Togashi); *Ôsaka-fu* - 1 ♂, Minoo, 27 v 1934 (Y. Sugihara); *Wakayama-ken* - 4 ♂, Amami-tôge, 24 iv 1964 (H. Katayama); *Hyôgo-ken* - 1 ♀, Sasayama, Tamba, 15 v 1964 (K. Iwata).

Shikoku: *Kôchi-ken* - 1 ♀, Engyôji, 15 iv 1930 (Y. Sugihara), 4 ♀ ♀, Kodakasa-yama, Kôchi-shi, 6 v 1930 (Y. Sugihara), 2 ♀ ♀, same loc., 30 iv 1931 (Y. Sugihara), 1 ♀, Yamada, 9 iv 1932 (Y. Sugihara), 1 ♂, Godai-san, Kôchi-shi, 7 v 1975 (SI), 1 ♂, same loc., 6 v 1976 (SI).

Distribution. Honshû; Shikoku; Kyûshû (Giordani Soika, 1975; Nagase, 1981). E. Siberia.

Taxonomic notes. I have examined one male and one female from Primorskij, eastern Siberia (sent by Dr. Kurzenko), which principally agree with *S. decens*. In the male, however, the truncated apical margin of clypeus is narrower than in the Japanese specimens. The female possesses two yellow spots on frons, and the yellow marking on antennal scape and paired pronotal markings are larger.

Biology. Iwata (1938b) observed the nesting behavior of this species (referred to as *Odynerus apiciornatus*) in Settsu, Honshû in May and June (1929-32). One or rarely two brood cells, and one to three empty cells are constructed in wheat straws used as roofs of cottages. Most nests have an empty cell just inside the entrance plug. Cell partitions (0.5-1 mm thick) and entrance plug (2 mm thick) are made of fine earth or red clay. The brood cell is provisioned with 4-11 (usually 5-8) mature larvae of a chrysomelid, *Phytodecta rubripennis*; the prey measures 5-8 mm in length.

Parasitoid: *Chrysis japonicus* was seen haunting colonial nesting sites of *S. decens* (Iwata, 1938b).

Symmorphus captivus (Smith)
(Figs. 230, 231, 238, 248, 258, 279)

Odynerus captivus Smith, 1873, Trans. R. Entomol. Soc. London, 1873: 197 (♀)(type loc.: "Hiogo", Japan); Schulthess, 1934, Arb. Morph. Taxon. Entomol. 1: 66; Giordani Soika, 1941, Boll. Soc. Venez. Stor. Nat. 2: 232.

Symmorphus captivus: Giordani Soika, 1975, Boll. Mus. Civ. Stor. Nat. Venez. 27: 150 (in key), 151-153, figs. 1, 7; Tsuneki, 1986, Spec. Publ. Jpn. Hymen. Assoc. 32: 22 (♂).

Japanese name: Ô-hamushi-dorobachi.

Diagnosis. Female. Body length (h+th+t1+2): ca. 12.5 mm. Fore wing length: ca. 12.0 mm. Head rather densely punctate on frons and ocular sinus, finely punctate in ocellar region, and sparsely punctate on gena and vertex. Cephalic foveae only slightly smaller than posterior ocelli, deep, each situated in a transverse depression; the depressions connected to each other by a furrow. Clypeus relatively finely and sparsely punctate; apical emargination relatively wide and its lateral teeth rather acute (Fig. 230). Flagellar segment 1 of antenna ca. 1.6 times as long as wide at its apex. Distance between the

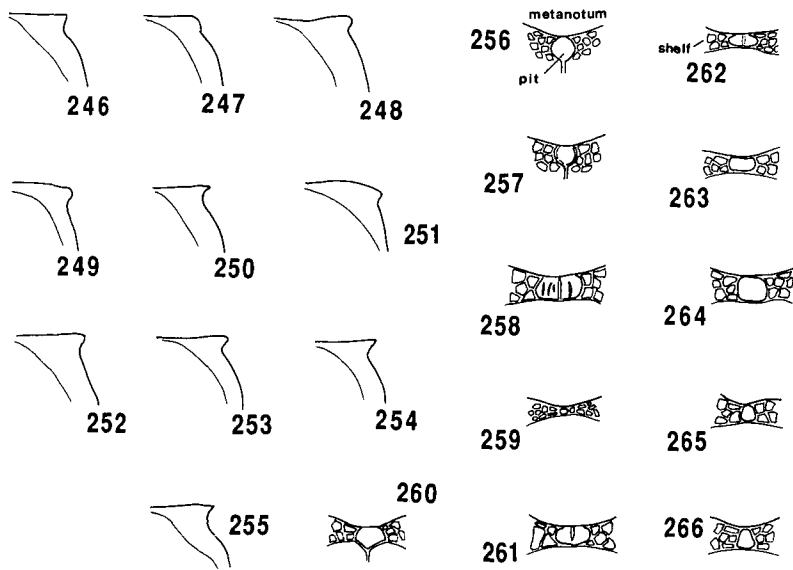

Figs. 246-255. Front corner (right) of male pronotum in Japanese *Symmorphus*. 246, *foveolatus*; 247, *decens*; 248, *captivus*; 249, *apiciornatus*; 250, *carinatus*; 251, *iwatai*; 252, *tsushmanus*; 253, *mutinensis*; 254, *mizuhonis*; 255, *cliens*.

Figs. 256-266. Shelf and pit of propodeum in Japanese *Symmorphus*. 256, *foveolatus*; 257, *decens*; 258, *captivus*; 259, *apiciornatus*; 260, *carinatus*; 261, *iwatai*; 262, *tsushmanus*; 263, *mutinensis*; 264, *mizuhonis*; 265, *cliens*; 266, *ishikawai*. In *foveolatus* and *decens* the shelf is virtually lacking (in the figures the area is not defined posteriorly).

posterior ocelli only slightly shorter than ocello-ocular distance (14:15). Pronotum rather coarsely punctate; pronotal carina widely interrupted in the middle; front corners of pronotum not produced. Mesoscutum much finely but densely macropunctate in its anterior half, but with only a few macropunctures and with numerous micropunctures in its posterior half; notaulices narrow but complete; parapsidal lines obscure; median scutal line visible only in anterior third. Epicnemial carina strong; epicnemium and dorsal mesepisternum sparsely macropunctate; ventral mesepisternum and mesepimeron densely macropunctate but punctures rather superficial. Metanotum coarsely macropunctate in anterior half; posterior half with weak vertical carinae; metapleuron with microscopic transverse striae, with irregular macropunctures or reticula in its lower portion, and with a deep pit just above the base of hind leg. Propodeum with a shelf that has a large median pit with several carinae on its bottom (Fig. 258). Dorsal and lateral parts of propodeum coarsely punctate. Propodeal concavity not sharply demarcated by inferior and superior ridges (the former ridge relatively well developed), shining, with irregular and indistinct carinae over the surface, and with a complete and high median carina. Anterior vertical part of gastral tergite 1 with ill-defined macropunctures, without distinct vertical carina; transverse carina shallowly incised in the middle; lateral part with irregularly shaped large punctures; posterior horizontal part with much smaller and dense punctures. Tergite 2 finely punctate; punctures tending to become larger toward base; tergites 3-5 superficially punctate in their apical portion. Punctuation on sternites 2-5

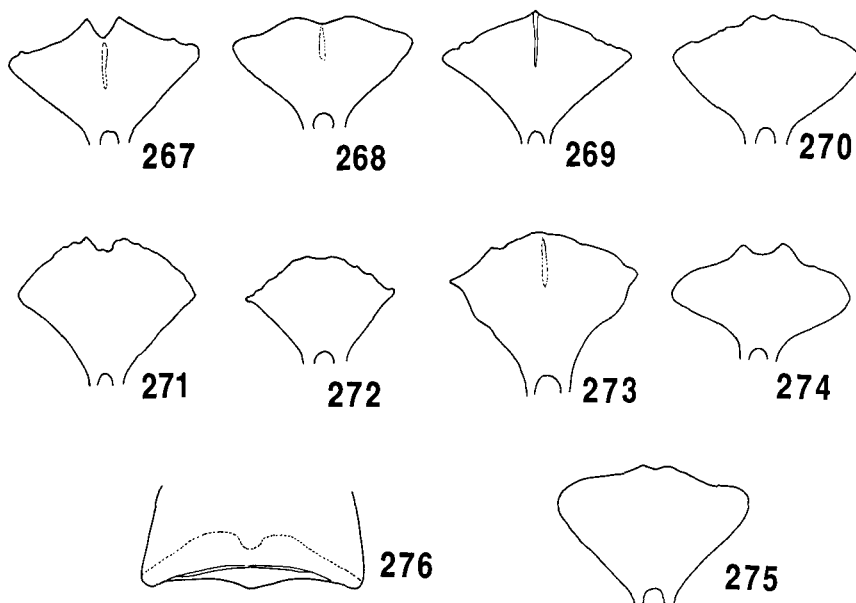

Figs. 267-275. Anterior face of gastral segment 1 in Japanese *Symmorphus*. 267, *apiciornatus* ♀; 268, ditto ♂; 269, *carinatus* ♀ ♂; 270, *iwatai* ♂; 271, *tsushmanus* ♂; 272, *mutinensis* ♀ ♂; 273, *mizuhonis* ♀ ♂; 274, *cliens* ♀ ♂; 275, *ishikawai* ♀.
 Figs. 276. Apical part of gastral tergite 1 of *S. tsushmanus*.

much finer than on corresponding tergites.

Body black, with the following parts yellow: a basal marking of variable size on clypeus, frontal spot (slightly tinged with orange), minute spot on temple, a pair of spots on pronotum anteriorly, a spot on dorsal mesepisternum (often lost), apical bands on gastral tergites 1, 2, 4 (band on t2 widest and that on t4 narrowest), a medially narrowed apical band on sternite 2, anterior faces of fore tibia and tarsus. Mandible ferruginous apically. Legs tinged with brown, especially on tarsi.

Male. Body length (h+th+t1+2): 8.5-9.5 mm. Fore wing length: 8.0-8.5 mm. The male differs from the female in the following details (also see Tsuneki, 1986): clypeus only slightly wider than high (Fig. 231), much more finely punctate, largely yellow; front corners of pronotum roundly produced (Fig. 248); mid tibia and tarsus also with yellow markings. Antennal segments 9-13 with distinct narrow tyloids that are yellowish; last segment slightly longer than wide at its base and nearly as long as segment 12 (Fig. 238).

Material examined. Honshû: *Aomori-ken* - 1 ♀, Zatôishi, Hirosaki, 20 vii 1973 (S. Takahashi); *Yamagata-ken* - 1 ♀, Ichino-taki (500 m alt.), Yamagata-shi, 23 vii 1973 (S. Takahashi); *Tochigi-ken* - 1 ♀, Senjugahara, Nikkô, 2 viii 1971 (HI); *Yamanashi-ken* - 2 ♂ 1 ♀, Shioyama, iv-v 1978, bred from a nest by Y. Tanaka.

Shikoku: *Kôchi-ken* - 1 ♀, Hirooka (H. Okamoto); *Kagawa-ken* - 1 ♀, Hirai-chô, Sanuki, 30 v 1948 (K. Iwata).

Distribution. Honshû; Shikoku. Korea. Smith (1873) mentioned "Hakodadi" as a locality of this species, but it is not certain whether "Hakodadi" denotes Hakodate (southern Hokkaidô) or not.

Biology. I have received 2 males and 1 female of this species bred from a nest by Mr. Y. Tanaka, who, however, has not published his nest data. This species may be a tube-renter. "*Odynerus (Symmorphus) captivus* Smith" reported for nesting biology by Iwata (1938b, 1971) was most probably *S. foveolatus* as suggested by Giordani Soika (1975).

Symmorphus sounkionis Tsuneki
(Fig. 279)

Symmorphus sounkionis Tsuneki, 1986, Spec. Publ. Jpn. Hym. Assoc. 32: 22, fig. 65 (♀) (type loc.: Sōunkyō, Hokkaidō).

Japanese name: Ezo-hamushi-dorobachi.

Diagnosis. Female. I have not examined any specimen of this species. Here, Tsuneki's (1986) original description is reproduced. "Closely related to *S. captivus* (Smith) and similarly a large-sized species, about 14 mm in length, but can be separated therefrom by the following differences: 1. clypeus without yellow mark, GT [gastral tergite] 3 apically yellow banded, but 4 without the band, mark on pronotum pointed at antero-lateral corners and mandible with a yellow mark at base on outer side; further GS 2 broadly, thoroughly banded at apex (in *captivus* medianly narrowed and interrupted); 2. antennal scape and flagellum ferruginous yellow beneath; 3. apical margin of clypeus narrower, with emargination much weaker; 4. longitudinal furrow of mesopleuron narrower, with lower margin more distinctly outlined and sectioned foveae more distinct; 5. side of propodeum almost without distinct longitudinal striae, only very sparsely, obscurely striate, with intervals faintly microstriolate, outward expansion at dorsal and posterior margins stronger, with punctures much less marked; 6. posterior aspect of propodeum obliquely, regularly, much more strongly and coarsely striate; 7. punctures on GT 1 much finer; 8. punctures at base and apex of mesoscutum much less different in size, surface very closely, subreticulately covered with large, uniform punctures, everywhere not bipunctate; 9. clypeus not bipunctate, anteriorly longitudinally rugosely and closely, posteriorly sparsely punctate; 10. frons more distinctly and closely rugoso-reticulate-punctate; 11. postscutellum and its posterior excavation somewhat different in structure from those of *captivus*".

Male. Unknown.

Distribution. Hokkaidō. This species is known only from the holotype collected at Sōunkyō at the foot of Mts. Taisetsu.

Symmorphus apiciornatus (Cameron)
(Figs. 239, 249, 259, 267, 280)

Anastrocerus apiciornatus Cameron, 1911, Entomologist, 44: 288 (♀ ♂) (type loc.: Japan).

Odynerus apiciornatus: Schulthess, 1934, Arb. Morph. Taxon. Entomol. 1: 74; Giordani Soika, 1941, Boll. Soc. Venez. Stor. Nat. 2: 232.

Symmorphus apiciornatus: Vecht and Fischer, 1971, Hym. Cat. (n. ed.) 8: 119; Giordani Soika, 1975, Boll. Mus. Civ. Venez. 27: 150 (in key), 156-158, figs. 4, 9.

Japanese name: Saijō-hamushi-dorobachi.

Diagnosis. Female. Body length (h+th+t1+2): 6.5-8.0 mm. Fore wing length: 7.0-8.0 mm. Head subcircular, relatively finely macropunctate; punctation on frons much denser than in other parts; frontal keel rather sharp; temple as seen from above wider than eye; cephalic foveae slightly smaller than posterior ocelli, not placed in depressions. Clypeus wider than high, very finely punctate, shallowly emarginate at apex. Distance between the posterior ocelli only slightly shorter than that between posterior ocellus and eye (11:12). Flagellar segments short; segment 1 (antennal seg. 3) as long as wide at its apex; subsequent segments wider than long. Pronotum moderately punctate, with a deep furrow in front of pronotal tubercle; front corners of pronotum round. Mesoscutum with relatively small macropunctures and numerous micropunctures that are not conspicuous; notaulices complete; parapsidal lines weak. Mesopleuron shining, with fine and sparse

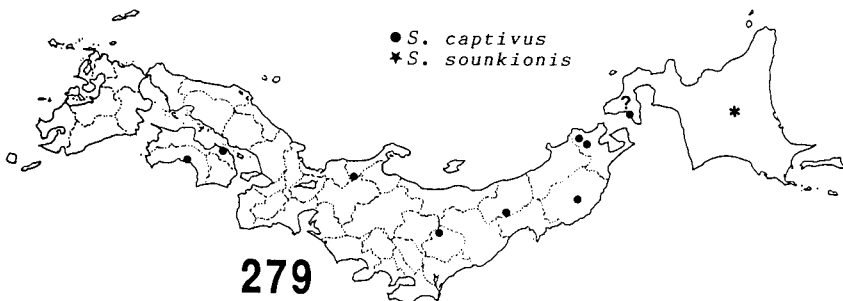
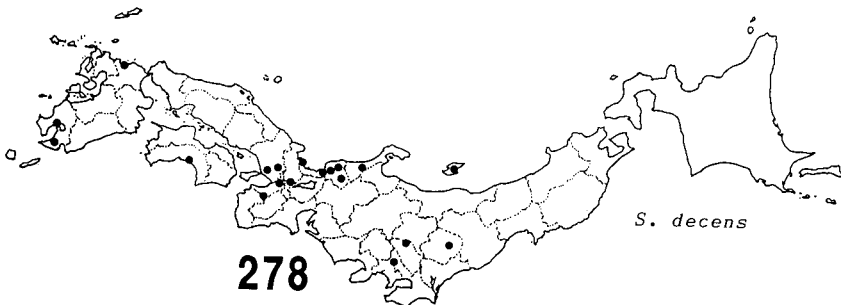
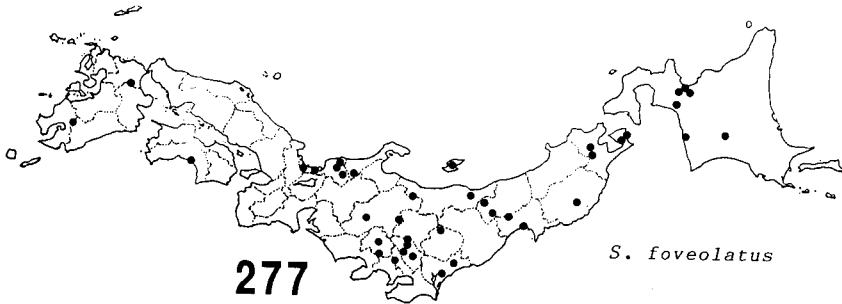

Figs. 277-279. Distribution of Japanese *Symmorphus* (I).

macropunctuation (posterior portion of ventral mesepisternum dull); epicnemial carina developed in its upper portion alone; scutellum nearly as wide as long, flat over the disc, with a median longitudinal furrow; macropunctuation on scutellum fine and sparse. Metanotum more coarsely punctate anteriorly, dull posteriorly. Metapleuron very finely and transversely striate above, dull below. Propodeal shelf very narrow; median pit small (Fig. 259); dorsal face irregularly reticulate; lateral face very finely striate, without distinct punctures; propodeal concavity not sharply demarcated by ridges, with fine striae that run obliquely, and with a complete median carina. Anterior face of gastral tergite 1 with a weak vertical median carina; transverse carina well developed, rather deeply incised in the middle (Fig. 267); posterior horizontal part coarsely punctate, apically slightly duplicate. Tergite 2 very faintly punctate at base; other tergites virtually without punctures; disc of sternite 2 very finely punctate at base; sternites 3-6 almost impunctate.

Black, with the following parts yellow: minute spot on temple, apical bands on tergites 1, 2 and 4 (the last often reduced or lost), and posterolateral spots on sternite 2, an irregular marking on the anterior face of fore tibia (often lost).

Male. Body length (h+th+t1+2): 5.5-6.0 mm. Fore wing length: 5.0-5.5 mm. Differs from the female in the following points: clypeus as wide as high, more narrowly emarginate at apex, largely yellow; mesal part of mandible extensively yellow; anterior face of antennal scape with a large yellow marking; 3 terminal segments of antenna ferruginous below; distance between posterior ocelli distinctly longer than that between posterior ocellus and eye; median incision of transverse carina on tergite 1 much shallower than in the female (Fig. 268); tergite 5 sometimes with a yellow apical band; tibiae and tarsi of all legs extensively yellow. Antennal segments 8-12 very thick; segments 10-13 each with a trace of tyloid; last segment very small, as wide as or wider than long at its base (Fig. 239).

Material examined. Hokkaidô: 1 ♂, Tokachi-dake (1000-2000 m alt.), 4-6 vii 1938 (T. Sawamoto & H. Takahasi).

Honshû: *Miyagi-ken* - 1 ♀, Tagajô, 4 vi 1983 (K. Goukon); *Fukushima-ken* - 5 ♂♂1 ♀, Yunohana, Aizu, 9 vi 1978 (HI); *Nagano-ken* - 1 ♀, Niiyama, Ina, 20 v 1962 (YM), 1 ♀, Takato, Ina, 19 v 1963 (YM); *Gifu-ken* - 2 ♀♀, Yôrô Park, Yôrô-gun, 6 v 1979 (Y. Takai); *Kyôto-fu* - 1 ♀, Iwakura, 10 v 1985 (T. Ichino); *Ishikawa-ken* - 1 ♀, Sodani, Tsurugi, 23 v 1985 (I. Togashi); *Shimane-ken* - 1 ♂, Mt. Makuragi, 25 iv 1983 (YM).

Sado-ga-shima (Niigata-ken): 1 ♂, Ogi, 18 v 1975 (A. Seino), 2 ♂♂1 ♀, bred from a nest by T. Ônuma (1987-88).

Shikoku: *Kôchi-ken* - 1 ♀, Kodakasa-yama, Kôchi-shi, 23 vi 1930 (Y. Sugihara), 1 ♀, same loc., 7 v 1931 (Y. Sugihara), 1 ♀, Susaki, 21 v 1933 (Y. Sugihara).

Distribution. Hokkaidô; Honshû; Sado-ga-shima; Shikoku; Kyûshû.

Biology. This species nests in *Miscanthus* stems, and hunt for mature larvae or prepupae of curculionids, *Rhyncaenus galloisi* and *R. takabayasii*, for the young (Nakatani, pers. comm.).

Parasitoid: *Melittobia acasta* (Hymenoptera, Eulophidae) (Maeta, 1985).

Symmorphus carinatus Sk. Yamane, spec. nov.

(Figs. 232, 233, 240, 250, 269, 281)

Japanese name: Tsuyakeshi-hamushi-dorobachi.

Diagnosis. Female. Body length (h+th+t1+2): 7.5 mm; fore wing length: 7.0 mm in the

holotype. Head wider than high, relatively densely punctate on frons and ocular sinus (punctures not well defined), much finely and sparsely punctate on gena and vertex and in ocellar region. Frontal carina sharp. Clypeus distinctly wider than high, very finely punctate above and more strongly punctate below; apical emargination shallow (Fig. 232). Cephalic foveae small, bearing brownish hairs. Distance between the posterior ocelli as long as that between posterior ocellus and eye. Antenna very short and thick; flagellar segment 1 thick, as long as wide at its apex. Pronotum coarsely macropunctate or reticulate in the lateral portion, much finely punctate along anterior margin of mesoscutum. Mesoscutum moderately macropunctate (punctures not clearly defined), with many micropunctures; notaulices complete; parapsidal lines obscure. Mesopleuron with sparse macropunctures; epicnemial carina complete; posterior portion of ventral mesepisternum shagreened; scutellum slightly wider than long, with a wide, ill-defined median furrow, moderately punctate. Metanotum coarsely macropunctate in anterior half and dull posteriorly; metapleuron wholly microscopically striate or shagreened. Propodeum with a distinct shelf which has a large median pit (Fig. 260); dorsal part of propodeum irregularly reticulate; lateral face much as metapleuron, with a few punctures above; propodeal concavity obliquely rugulose, somewhat shining, with a complete median carina. Anterior vertical face of gastral tergite 1 with a strong median vertical carina; transverse carina not incised in the middle (Fig. 269); posterior horizontal part of the tergite with large punctures which are ill defined, with a median furrow which is shallow and indistinct. Tergite 2 finely punctate at base; other tergites almost impunctate. Disc of sternite 2 very finely punctate at base.

Black; the following parts yellow: a pair of spots on frons, spot on temple, a pair of spots on pronotum anteriorly, a relatively large spot on dorsal mesepisternum, apical bands on tergites 1, 2, 4 (the last interrupted medially), an incomplete apical band on sternite 2, fore and mid tibiae on anterior face extensively. Legs somewhat brownish.

Male. Body length (h+th+t1+2) 6.5 mm, fore wing length 6.5 mm in the paratype. Similar to the female but different therefrom in the following points: clypeus largely yellow, antennal scape with a yellow stripe below, 3 terminal segments of antenna with ferruginous stripes below, mandible with a yellow mark in mesal portion, distance between the posterior ocelli longer than that between posterior ocellus and eye, front corners of pronotum acute to some extent (Fig. 250), median pit of propodeal shelf with a distinct longitudinal carina on the bottom, fore and mid tibiae and tarsi of all legs more extensively yellow. Flagellar segments of antenna rather thick; antennal segments 11-13 each with a trace of tyloid; last segment small, wider than long at its base (Fig. 240).

Holotype. ♀, Kodakasa-yama, Kôchi-shi, Kôchi-ken, Shikoku, 7 v 1931 (Y. Sugihara).

Paratype. ♂, Engyôji, Kôchi-shi, 19 iv 1931 (Y. Sugihara).

Distribution. Shikoku.

Taxonomic notes. This species resembles *S. apiciornatus* in the sculpture of metapleuron and of the lateral face of propodeum, but is distinguished from the latter by the following aspects: propodeum with a wider shelf which has a large median pit, transverse carina on tergite 1 not interrupted medially, and alitrunk with yellow markings.

I have examined one male specimen from Honshû (Mt. Hayachine, Iwate-ken, 1 viii 1965, A. Nakanishi leg.) which largely agrees with the paratype male but differs in the following details: striae on metapleuron and the lateral face of propodeum coarser, posterior horizontal part of tergite 1 reticulate rather than punctate, and yellow markings on mesosoma much reduced.

Symmorphus iwatai Sk. Yamane, spec. nov.
(Figs. 234, 241, 251, 261, 270, 281)

Japanese name: Iwata-hamushi-dorobachi.

Diagnosis. Male. Body length (h+th+t1+2): 7.5 mm; fore wing length: 8.0 mm in the holotype. Head distinctly wider than high; width : height (from top to lower margin of clypeus) = 73 : 67. Punctures on frons and ocular sinus dense and not uniform in shape and size; region between the antennae raised to form "tubercle"; frontal keel rather sharp; anterior tentorial pit deep. Punctuation on gena and vertex and in the area surrounded by the ocelli much sparser. Clypeus slightly wider than high, very finely punctate, apically

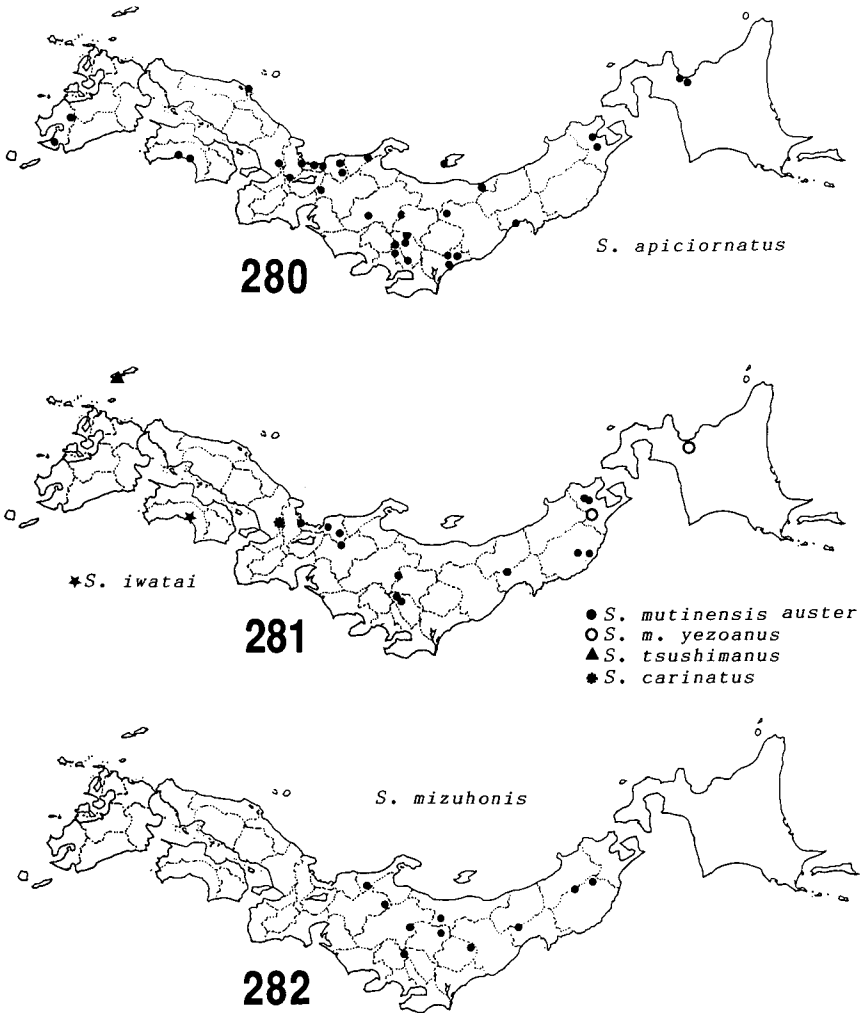

Figs. 280-282. Distribution of Japanese *Symmorphus* (II).

rather deeply emarginate, with acute lateral teeth (Fig. 234). Distance between the posterior ocelli longer than ocello-ocular distance (12:10). Temple as seen from above slightly narrower than eye. Flagellar segments of antenna moderately thick; antennal segments 9-13 with rather distinct tyloids; last segment slightly longer than wide at its base, nearly as long as segment 12 (Fig. 241). Pronotum macropunctate in dorsal part (punctures not uniform), strongly and transversely striate on lateral face; pronotal carina developed but much reduced medially; front corners of pronotum slightly angulate (Fig. 251). Mesoscutum with coarse punctation mainly in anterior half; micropunctures more numerous in posterior portion; notaulices well defined and relatively deep; parapsidal lines carinate. Epicnemial carina well developed, extending from the lower margin of dorsal mesepisternum to the base of mid leg; epicnemium with a few macropunctures below; dorsal mesepisternum finely and very sparsely macropunctate; ventral mesepisternum and mesepimeron rather strongly punctate; the area surrounded by mesepisternum and mesepimeron broadly concave; posterior portion of ventral mesepisternum shagreened. Scutellum with large, irregular punctures; median furrow indistinct. Metanotum anteriorly coarsely sculptured, posteriorly dull; metapleuron striate above, shagreened below. Propodeal shelf present, with a distinct median pit; the bottom of the pit sloping and with a vertical carina (Fig. 261). Dorsal face of propodeum coarsely punctate or reticulate; lateral face finely striate. Propodeal concavity not sharply demarcated by ridges, superficially striate, with a complete median carina. Anterior face of gastral tergite 1 with ill-defined, large punctures, without median vertical carina. Transverse carina of tergite 1 interrupted in the middle (Fig. 270), laterally not connected with the carinae that extend from the preapical swelling with a yellow apical band. Posterior horizontal part of tergite 1 with coarse punctures which are variable in shape and size, slightly duplicate at apex. Tergite 2 finely punctate at base; tergites 3-5 slightly more strongly punctate near apex. Disc of sternite 2 punctate at base; punctation on sternites 3-5 much finer than on corresponding tergites.

Black, with the following parts yellow: clypeus almost wholly, spot on temple, a pair of triangle markings on propodeum anteriorly, apical band on tergite 1, wider band on tergite 2, apical band on sternite 2 which is dilated laterally and narrowly interrupted at middle, apex of fore femur, tibiae and tarsi of all legs extensively. Tyloids of apical 4 segments of antenna ferruginous.

Female unknown.

Holotype. ♂, Jōhoku, Sasayama, Hyōgo-ken, Honshū, 8 v 1957 (K. Iwata).

Distribution. Honshū.

Biology. On the data label, Iwata wrote "Yanagihamushi" [*Chrysomela vigintipunctata*, Chrysomelidae], though it is not certain whether this specimen was bred from a nest by Iwata.

Symmorphus tsushimanus Sk. Yamane, spec. nov.

(Figs. 235, 242, 252, 262, 271, 276, 281)

Japanese name: Tsushima-hamushi-dorobachi.

Diagnosis. Male. Body length (h+th+t1+2): 6.5 mm, fore wing length: 7.0 mm in the holotype. Head wider than high, with medium-sized punctures that are smaller between

the posterior ocelli and sparse on the vertex and gena, and with erect hairs which are longer than hairs on thorax and gaster. Clypeus wider than high, finely punctate above and more strongly but sparsely punctate below, anteriorly very shallowly emarginate (Fig. 235). Temple seen from above as wide as eye. Antenna club-shaped, with thickened flagellum; scape as long as pedicel + flageller segment 1; antennal segments 10-13 with ill-defined tyloids; tyloids on the last two segments wide; last segment as long as wide at its base (Fig. 242). Pronotum with medium-sized macropunctures on dorsal part, macropunctate and striate on lateral face; pronotal carina sharp; front corners only slightly produced (Fig. 252). Mesoscutum rather strongly macropunctate; spaces between punctures generally larger than punctures and with numerous micropunctures; macropunctuation much denser near the base of mesoscutum; notaulices complete; parapsidal lines slightly raised; median scutal line visible only in anterior third. Scutellum sparsely macropunctate except in the posterior region, with a median furrow. Epicnemium very weakly macropunctate, almost impunctate above; dorsal mesepisternum macropunctate only in posterior part; ventral mesepisternum sparsely macropunctate; macropunctuation on mesepimeron denser than on mesepisternum; epipleural suture wide, with several transverse carinae; posterior part of ventral mesepisternum shagreened. Metanotum coarsely punctate in anterior half and shagreened in posterior part; metapleuron finely striate. Propodeum with a narrow but distinct shelf which has a deep median pit (Fig. 262); the shelf and dorsal face of propodeum coarsely macropunctate or reticulate; propodeal concavity microstriate over the surface and its median carina distinct. Lateral face of propodeum striate, with large punctures posteriorly. Gastral segment 1, seen from above, as long as wide. Anterior face of gastral tergite 1 with ill-defined macropunctures laterally, without vertical carina; transverse carina narrowly and shallowly incised in the middle (Fig. 271); dorsal horizontal part strongly punctate; posterior lamella medially produced backward (Fig. 276; this condition is peculiar to this species among the Japanese species). Sternite 1 also strongly punctate. Other tergites and sternites much more finely punctate. Anterior faces of coxae and femora below with silver hairs.

Black, with yellow and orange yellow markings as follows: a transverse spot between antennae, upper half of clypeus, a large marking on antennal scape below, apical 3 or 4 antennal segments below, small spot on temple, a pair of triangular marking on pronotum anteriorly, spot on dorsal mesepisternum, a pair of spots on scutellum, apical band on

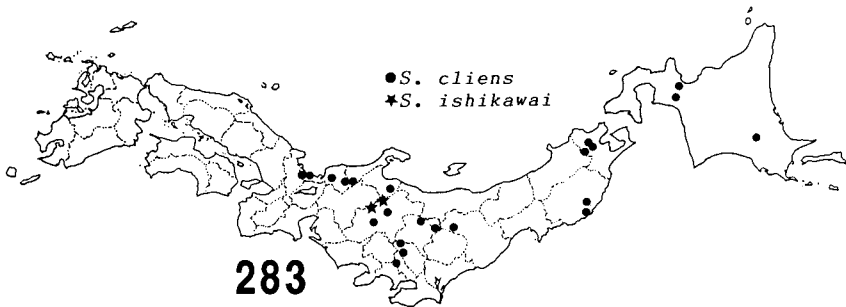

Fig. 283. Distribution of Japanese *Symmorphus* (III).

tergite 1 (medially widened with anterior incision), wide apical band on tergite 2 somewhat sinuate, a medially interrupted narrow apical band on tergite 3, narrow but complete apical bands on tergites 4 and 5, medially interrupted apical band on sternite 2, apices of fore and mid femur, anterior face of fore tibia, segment 1 of fore tarsus, irregular markings on the outer face of mid tibia. Legs blackish brown, marked with yellow as mentioned above.

Holotype. ♂, top of Ariake-san (558 m alt.), Tsushima Is., 4 vii 1975 (Y. Miyatake). Deposited in the Collection of Osaka City Museum of Natural History.

Distribution. Tsushima Is. (Shimo-agata).

Symmorphus mutinensis (Baldini)

(Figs. 243, 253, 263, 272, 281)

Odynerus (*Protodynerus*) *sinuatus* var. *mutinensis* Baldini, 1894, Atti Soc. Nat. Modena, (3)13: 78, pl. 3, fig. 6 (type loc.: environs of Modena, Italy?).

Odynerus (*Symmorphus*) *mutinensis*: Blüthgen, 1961, Faltenwespen Mitteleuropas, p. 188 (in key), 197, 198.

Symmorphus mutinensis: Vecht and Fischer, 1972, Hym. Cat. (n. ed.) 8: 122.

Japanese name: Mitsuten-hamushi-dorobachi.

Diagnosis (based upon subsp. *auster* G. S.). Female. Body length (h+th+t1+2): 6.5-7.5 mm. Fore wing length: 6.5-7.0 mm. Head subcircular, strongly and irregularly punctate on frons and ocular sinus, finely and sparsely punctate on vertex and gena. Frontal carina sharp. Clypeus much wider than high, strongly convex, finely punctate above, strongly and sparsely punctate below, relatively shallowly emarginate at apex; lateral teeth of the emargination blunt. Cephalic foveae half as large as posterior ocelli in diameter. Distance between the posterior ocelli as long as or slightly longer than ocello-ocular distance. Flagellar segment 1 of antenna 1.2 times as long as wide at its apex. Pronotum irregularly macropunctate; spaces between punctures with numerous micropunctures along posterior margin of pronotum; depression just in front of pronotal tubercle very large, with sharp carinae on its bottom. Mesoscutum distinctly duplipunctate; macropunctuation denser in anterior portion; micropunctuation dense and very conspicuous over the disc; notaulices complete, deep near the base of disc; parapsidal lines carinate; median scutal line running from anterior margin to basal margin of the disc, forming a narrow groove in basal half. Epicnemial carina well developed, sometimes extending onto dorsal mesepisternum; epicnemium above almost impunctate; dorsal and ventral mesepisternum with large and sparse punctures; mesepimeron densely macropunctate or even reticulate; posterior part of ventral mesepisternum shagreened, slightly shining. Scutellum with a few large punctures and numerous micropunctures, with wide median furrow; narrow posterior zone with many short carinae. Metanotum coarsely and irregularly macropunctate; its posterior zone smooth, somewhat shining; metapleuron finely striate above and coarsely striate in anterior portion of lower half. Propodeal shelf distinct, with a large median pit (Fig. 263). Dorsal face of propodeum including the shelf coarsely punctate or reticulate; lateral face strongly punctate in upper and posterior portion, finely striate toward the border with metanotum. Propodeal concavity defined only below, with superficial microstriation over its surface, with a complete median carina. Anterior face of gastral tergite 1 without distinct punctures and median carina; transverse carina not interrupted

or only shallowly incised in the middle (Fig. 272), extending backward from both lateral ends to be connected with preapical swelling; posterior horizontal part coarsely punctate, with inconspicuous micropunctures. Tergite 2 with superficial punctures at base; other tergites almost impunctate. Basal half of the disc of sternite 2 distinctly punctate; sternites 3-6 almost impunctate.

Male. Body length (h+th+t1+2): 5.5-6.5 mm. Fore wing length: 6.0-6.5 mm. Sculpture as in the female. Front corners of pronotum more produced (Fig. 253). Median scutal line obscure. Macropunctuation on mesoscutum much stonger and denser. Antennal segments 10-13 with ill-defined tyloids; last segment slightly longer than wide at its base and nearly as long as segment 12 (Fig. 243).

This species is widely distributed in the Palearctic region. The nesting biology of this species was studied by Enslin (1921) and Jørgensen (1942) in Europe (referred to as *S. sinuatus* Fabricius). Female wasps construct their nests in bramble straws and thatch. The cell partitions are made of clay. The number of cells constructed per nest ranges between 4 and 8 in the nests made in bramble straws, and between 1 and 6 (mostly 1 and 2) in those made in thatch. Larval cells are provisioned with chrysolimid larvae. Enslin (1921) reported that larvae of Microlepidoptera were found in nests of this species, though this has not been confirmed by other authors.

In Japan two subspecies, *auster* Giordani Soika and *yezoanus* Tsuneki, are known to occur; both are not common in any locality.

Symmorphus mutinensis auster Giordani Soika
(Fig. 281)

Symmorphus mutinensis auster Giordani Soika, 1975, Boll. Mus. Civ. Stor. Nat. Venez. 27: 150 (in key), 160, 161 (♀) (type loc.: Mt. Hayachine, Iwate-ken); Tsuneki, 1977, Spec. Publ. Jpn. Hym. Assoc. 5: 16 (♂).

Japanese name: Mitsuten-hamushi-dorobachi.

Diagnosis. Female. Black, with the following parts yellow or orange yellow: transverse frontal marking, minute spot on temple, a pair of spots on scutellum (sometimes lost), apical band on gastral tergite 1 (medially widened and anteriorly incised at middle), a sinuated apical band on tergite 2, much narrower bands on tergite 4 and sternite 2, anterior face of fore tibia, mid and sometimes hind tibiae partly. Legs black, but tinged with brown especially on tibiae and tarsi.

Male. Body markings paler than in the female. Mandible and/or clypeus often with irregular yellow markings. Tyloids on 4 terminal segments of antenna ferruginous. Scutellum always wholly black. Tarsi of all legs at least partly yellowish.

Material examined. Honshū: *Aomori-ken* - 1 ♂, Yamagata, 16 vi 1936 (I. Tateyama), 3 ♂♂, Zatōishi, Hirosaki, 29 vi 1983 (M. Yamada); *Iwate-ken* - 2 ♂♂, Kadoma-guchi, Mt. Hayachine, 28 vii - 1 viii 1965 (A. Nakanishi); *Miyagi-ken* - 1 ♂, Mt. Zaō, 19 vi 1983 (K. Goukon); *Nagano-ken* - 1 ♀, "Shinshū", 4 viii 1929 (Y. Ota); *Fukui-ken* - 1 ♂, Nakamura, Ōno, 12 vi 1971 (TT), 1 ♀, Itoshiro Riv. 25 vii 1973 (TT), 1 ♂, Arashiguchi - Ōno, 24 vi 1980 (H. Kurokawa), 1 ♀, Nagatani - Obama, 25 vii 1980 (H. Kurokawa); *Gifu-ken* - 1 ♀, Itoshiro, Shiratori, 21 ix 1986 (Y. Takai).

Distribution. Honshū.

Biology. In Niigata-ken, this form nests in bamboo tubes. One to five brood cells are constructed in a tube nest. The prey is not identified (T. Ōnuma, pers. comm.).

Symmorphus mutinensis yezoanus Tsuneki
(Fig. 281)

Symmorphus mutinensis yezoanus Tsuneki, 1977, Spec. Publ. Jpn. Hym. Assoc. 5: 16, 17 (♂♀)(type loc.: Sapporo, Hokkaidô).

This subspecies is said to be distinguished from ssp. *auster* by several aspects of punctation (Tsuneki, 1977). It has been known from Hokkaidô and the northernmost part of Honshû where it may occur together with ssp. *auster*. As Tsuneki mentioned, further study with ample material is necessary to solve the subspecies problem in this species in Japan.

Symmorphus mizuhonis Tsuneki
(Figs. 244, 254, 264, 273, 282)

Symmorphus mizuhonis Tsuneki, 1977, Spec. Publ. Jpn. Hym. Assoc. 5: 17-20 (♂♀)(type loc.: Okunasu, Tochigi-ken, Honshû).

Japanese name: Mizuho-hamushi-dorobachi.

Diagnosis. Female. Body length (h+th+t1+2): 7.0-8.5 mm. Fore wing length: 6.5-8.0 mm. Head strongly punctate on frons and ocular sinus, more finely and sparsely on gena and vertex. Clypeus finely and sparsely macropunctate, much less swollen than in *S. mutinensis*, relatively widely emarginate at apex. Cephalic foveae very small, usually less than half as large as posterior ocelli in diameter, situated more distantly from posterior ocelli than in *S. mutinensis*. Distance between the posterior ocelli distinctly shorter than ocello-ocular distance (8:10). Flagellar segment 1 of antenna slightly longer than wide at its apex. Pronotum moderately macropunctate in dorsal part, much more densely on lateral face (spaces between punctures tend to form carinae); pronotal carina well developed to form lamella in the lateral face of pronotum, but almost absent dorsally; front corners of pronotum, seen from above, rather strongly produced as in *S. mutinensis*. Mesoscutum densely micropunctate over the disc, sparsely with small macropunctures; notaulices evanescent in anterior half except for anterior excavation; parapsidal lines inconspicuous; median scutal line undeveloped, not forming a furrow near the base of disc. Mesopleuron with a few macropunctures; epicnemial carina complete but not extending onto dorsal mesepisternum; posterior portion of ventral mesepisternum shagreened. Scutellum smooth, with a few small macropunctures, with a wide median furrow, and posteriorly shagreened. Metanotum irregularly sculptured anteriorly, somewhat shining; posterior half shagreened; metapleuron finely striate and partly shagreened. Propodeum with relatively wide shelf which has a very large median pit (Fig. 264); dorsal face of propodeum including the shelf coarsely punctate or reticulate; lateral face striate below, and with large punctures above. Propodeal concavity well demarcated in lower half, with a complete median vertical carina which is connected with the ridge encircling the median pit; surface of concavity irregularly striate. Anterior vertical face of gastral tergite 1 with a few ill-defined punctures, with a trace of vertical carina; transverse carina not incised medially (Fig. 273); posterior horizontal part of the tergite weakly punctate, with a short median carina at base. Tergite 2 finely punctate (punctures become

stronger and denser toward the base); punctuation on other tergites and sternites 2-6 much finer.

Black, with the following parts yellow: two contiguous markings on frons, minute spot on temple, medially widened apical band on tergite 1 (anteriorly incised in the shape of a triangle), relatively regular band on tergite 2, narrower and sinuated band on sternite 2. All the legs wholly blackish. Wings rather strongly clouded.

Male. Body length (h+th+t1+2): 6.0-7.5 mm. Fore wing length: 6.0-7.5 mm. Similar to the female in structure and coloration. Clypeus and/or mandible often marked with yellow. Distance between the posterior ocelli slightly longer than ocello-ocular distance. Front corners of pronotum more pronounced than in the female (Fig. 254). Anterior face of fore tibia marked with yellow. Antennal segments 11-13 with tyloids; tyloid on segment 11 evanescent; last segment small, shorter than segment 12 (Fig. 244); two or three apical segments sometimes extensively ferruginous.

Material examined. Honshû: *Akita-ken* - 2 ♂♂ 1 ♀, Mt. Nyûtô, 6 viii 1983 (M. Yamada); *Iwate-ken* - 1 ♀, Ashiro, 19 ix 1976 (YM); *Miyagi-ken* - 4 ♂♂ 1 ♀, Kamoshika Spa, Mt. Zaô, 25 vi 1979 (TN), 1 ♀, Mt. Zaô, 22 viii 1979 (K. Kojima & T. Nishida), 1 ♀, same loc., 31 viii 1979 (K. Goukon); *Niigata-ken* - 1 ♂, Yuzawa, 8 viii 1966 (HI); *Tochigi-ken* - 1 ♂, Okunasu, 26 vii 1970 (TN); *Gumma-ken* - 1 ♂, Buson-sanroku, 21 vii 1974 (HI); *Saitama-ken* - 1 ♂ 1 ♀, Karisaka-tôge, Otaki, 29 vii 1983 (TN); *Nagano-ken* - 4 ♂♂, Mt. Komaga-take, Ina, 19 vii 1962 (K. Oshima); *Ishikawa-ken* - 1 ♀, Haku-san, 2 viii 1962 (T. Naito); *Gifu-ken* - 1 ♀, Migimata-dani (1500-2000 m alt.), Mts. Hida, 7-8 viii 1987 (Y. Takai).

Distribution. Honshû (mountainous regions).

Symmorphus cliens Giordani Soika
(Fig. 245, 255, 265, 274, 283)

Symmorphus cliens Giordani Soika, 1975, Boll. Mus. Civ. Stor. Nat. Venez. 27: 150 (in key), 158, 159, figs. 5, 10 (♀ ♂) (type loc.: Mt. Hayachine, Iwate-ken, Honshû).

Japanese name: Katatoge-hamushi-dorobachi.

Diagnosis. Female. Body length (h+th+t1+2): 5.5-7.0 mm. Fore wing length: 5.5-6.5 mm. Head subcircular; punctuation on head similar to that in *mizuhonis*, but slightly stronger on gena. Frontal keel sharp. Clypeus distinctly wider than high, more swollen than in *mizuhonis*, sparsely macropunctate and micropunctate over the disc; apical margin shallowly emarginate. Cephalic foveae relatively large, more than half the diameter of posterior ocelli. Distance between the posterior ocelli slightly longer than ocello-ocular distance. Flagellar segment 1 of antenna small, only slightly longer than pedicel, nearly as long as wide at its apex. Pronotum densely macropunctate; spaces between punctures tend to run into carinae in lower portion of lateral face; pronotal carina not distinctly lamellate on the lateral face of pronotum, weakened dorsally; front corners of pronotum somewhat angulate but less pronounced than in *mizuhonis*. Mesoscutum much more strongly macropunctate over the disc; micropunctures less conspicuous than in *mutinensis*; notaulices complete but narrow and shallow in its anterior half; parapsidal lines weak; median scutal line absent in the basal half of the disc. Epicnemial carina complete, not extending onto dorsal mesepisternum; epicnemium and dorsal mesepisternum almost impunctate; ventral mesepisternum with a few macropunctures, posteriorly shagreened; mesepimeron sparsely macropunctate. Scutellum sparsely macropunctate, posteriorly with short carinae; micropunctuation inconspicuous. Metanotum irregularly sculptured

anteriorly, smooth and shining posteriorly; metapleuron striate above, smooth below. Propodeal shelf relatively narrow; median pit distinctly smaller than in *mizuhonis*, often a narrow slit (Fig. 265). Dorsal face of propodeum including the shelf coarsely punctate or reticulate; lateral face striate, with some large punctures above. Propodeal concavity well defined below, lustrous, with superficial striae over the surface and with a complete median carina. Anterior face of gastral tergite 1 with ill-defined punctures; vertical carina almost invisible; transverse carina roundly incised in the middle (Fig. 274); posterior horizontal part more weakly and sparsely punctate than in *mizuhonis*, without median carina at base. Tergite 2 basally sparsely punctate; punctation very weak in apical 1/2. Punctation on other tergites finer. Sternite 2 rather strongly punctate in the basal half of the disc; sternite 2 in apical part and other sternites much more finely punctate.

Black; the following parts yellow: two contiguous markings on frons (rarely lost), medially widened apical band on tergite 1 (anteriorly incised at the middle), slightly sinuated band on tergite 2, an incomplete narrow band on tergite 4 (sometimes lost), sinuated band on sternite 2, anterior face of fore tibia. Terminal segment of antenna ferruginous below. Legs blackish brown.

Male. Body length (h+th+t1+2): 5.5-6.5 mm. Fore wing length: 5.5-6.0 mm. Clypeus more finely punctate than in the female, with a large irregular yellow marking. Mandible yellow-maculated. Frontal mark always absent. Apical band on tergite 4 often much reduced or lost. Fore and mid tibiae extensively yellow. Antennal segments 11-13 with rather distinct tyloids; last segment very small (Fig. 245) and wholly orange in color; segments 11 and 12 often partly orange.

Material examined. Hokkaidô: 2♀♀, Shikotsu-ko, 17 vii 1977 (SKY).

Honshû: *Aomori-ken* - 4♀♀, Hirosaki, 5 vii 1976 (SKY), 1♀, Sôma, 31 vii 1982 (M. Yamada), 1♀, Ikarigaseki, 14 viii 1982 (M. Yamada), 2♀♀, Mt. Bonju, Namioka, 2 vii 1983 (M. Yamada), 2♀♀, Kuroishi, 9 vii 1983 (M. Yamada), 1♀, same loc., 27 viii 1983 (M. Yamada); *Akita-ken* - 1♀, Mt. Nyûtô, 5 viii 1983 (M. Yamada); *Fukushima-ken* - 1♂, Yunohana, 24 vi 1977 (H. Koike); *Niigata-ken* - 1♂, Gimpei-zan, bred from a nest by T. Ônuma (1987-88); *Gumma-ken* - 7♂♂, Hôshi Spa, 24 vi 1984 (A. Seino); *Saitama-ken* - 1♀, Izugadake, 3 vii 1984 (S. Aoki); *Nagano-ken* - 1♀, Mt. Nyûgasa, Ina, 17 vii 1962 (YM).

Distribution. Hokkaidô; Honshû.

Biology. This species constructs its nests in bamboo tubes (3-4 mm in diam.). The nesting was observed between June and October in a mountainous region of Niigata-ken (Ônuma, 1989b).

Symmorphus ishikawai Giordani Soika
(Figs. 266, 275, 283)

Symmorphus ishikawai Giordani Soika, 1975, Boll. Mus. Civ. Stor. Nat. Venez. 27: 151 (in key), 159, 160 (♂♀)(type loc.: Yokoo (1600 m alt.), Nagano-ken).

Japanese name: Soten-hamushi-dorobachi.

Diagnosis. Female. Body length (h+th+t1+2): 7.0-8.0 mm. Fore wing length: 7.0-7.5 mm. Head higher than wide, densely macropunctate on frons and ocular sinus; punctation on these parts slightly sparser and much finer than in *mizuhonis* and *cliens*; gena finely and vertex very weakly macropunctate. Clypeus wider than high, shallowly emarginate apically, with relatively large micropunctures densely over the disc; apical part with a few ill-defined macropunctures. Cephalic foveae very large, as large as posterior

ocelli. Distance between the posterior ocelli as long as ocello-ocular distance. Temple as seen from above slightly wider than eye. Occipital carina relatively gradually curved, not forming a distinct angle at some distance from mandibular base. Flagellar segment 1 of antenna only slightly longer than wide at its apex. Pronotum dorsally weakly macropunctate (punctures ill defined), in lateral face more strongly punctate (spaces between punctures running into carinae); front corners of pronotum less produced than in *mizuhonis* and *cliens*. Mesoscutum finely micropunctate, with sparse, small macropunctures that are ill defined; notaulices complete, rather deep over its length; parapsidal lines weak; median scutal line weak, but extending toward the base of disc as a shallow, weak furrow. Epicnemial carina developed but not extending onto dorsal mesepisternum; epicnemium above and dorsal mesepisternum impunctate; ventral mesepisternum and mesepimeron sparsely and finely macropunctate; posterior portion of dorsal mesepisternum shagreened but somewhat lustrous. Scutellum finely micropunctate; posterior zone with irregular carinulae. Metanotum almost smooth posteriorly; metapleuron strongly striate above, rather smooth below. The condition of propodeal shelf and dorsolateral portion of propodeum as in *cliens*, but the median pit slightly larger (Fig. 266). Lateral face of propodeum striate below, reticulate above. Propodeal concavity relatively well defined by ridges, with almost smooth surface; median carina complete. Anterior vertical face of gastral tergite 1 without vertical carina; transverse carina very shallowly incised in the middle (Fig. 275); posterior horizontal part without basal carina, superficially and sparsely macropunctate. Tergite 2 and sternite 2 finely and sparsely macropunctate at base. Other tergites and sternites almost impunctate.

Black; the following parts yellow or orange yellow: two contiguous frontal spots, minute spot on temple, apical bands on tergites 1 and 2, apical band on sternite 2 medially widely interrupted. Legs wholly blackish brown.

Male. According to Giordani Soika (1975), clypeus apically with a large yellow marking, frons without marking, antennal segments 10-13 below with ferruginous markings, anterior faces of fore and mid tibiae yellow, and fore femur apically yellow.

Material examined. Honshû: *Nagano-ken* - 2 ♀ ♀, Yokoo (1600 m alt.) nr Kamikôchi (type loc.), 30 vii 1957 (R. Ishikawa).

Distribution. Honshû (*Nagano-ken*)

Biology. No information is available.

Genus "*Pachymenes*" Saussure

Pachymenes Saussure, 1852, Et. Fam. Vesp. 1: 73-77 (type species: *Pachymenes sericea* Saussure, 1852, designated by Ashmead, 1902); 1855, Et. Fam. Vesp. 3: 152, 153; Bequaert, 1918, Bull. Amer. Mus. Nat. Hist. 39: 87.

Japanese name: Tokkuribachi-modoki Zoku.

This genus is a mixture of species with the following character conditions, and is distributed in the warmer regions of the world (Bequaert, 1918): "clypeus pyriform, truncate or bidentate at its apex; mandibles lengthened, crossing each other in an X, dentate or lobate along their inner margin; mouth parts as in *Eumenes*, *Odynerus*, and *Nortonia*; shape of the abdomen intermediate between that of *Eumenes* and that of *Odynerus* subgenus *Rhygchium*; its first segment funnel-shaped, subcampanulate; the first tergite without any trace of transverse carina; the abdomen as a rule depressed".

According to Vecht (pers. comm., 1981) the Oriental "*Pachymenes*" species differ from the true *Pachymenes* of South America, and he is going to describe a new genus for the Oriental forms (see also Giordani Soika, 1986).

"Pachymenes" yayeyamensis (Matsumura)
(Figs. 284-287, 355C, 361)

Odynerus yayeyamensis Matsumura, 1926, Ins. Matsum. 1: 36, pl. 3, fig. 11 (nec 12) (♂)(type loc.: Okinawa-hontô ?).

"Pachymenes" yayeyamensis (Mats.): Giordani Soika, 1986, Boll. Mus. Civ. Stor. Nat. Venez. 35: 67-71, figs. 5-9.

Odynerus hôkotôensis Sonan, 1929, Trans. Nat. Hist. Soc. Formosa, 19: 534, 535 (♀ ♂)(type loc.: "Hôkotô", Taiwan).

Pachymenes fragilis (Sm.): Yasumatsu, 1938, Trans. Nat. Hist. Soc. Formosa, 28: 446-447; Azuma and Kinjo, 1987, Check-list Ins. Okinawa, p. 315.

Odynerus (Lionotus) fragilis Sm.: Schulthess, 1934, Arb. Morph. Taxon. Entomol. 1: 94 (in key; from Taiwan).

Japanese name: Hime-tokkuribachi-modoki.

For diagnosis see Giordani Soika (1986).

Material examined. C. Ryukyus: *Yoron-tô* - 1 ♀, 4 vi 1985 (SKY), 1 ♂, 24-8 v 1986 (SKY); "*Okinawa*" - 1 ♂ (S. Sakaguchi).

S. Ryukyus: "*Yaeyama*" - 1 ♂, "vii[?] 0'7 (SK)" (type); *Miyako-jima* - 1 ♀, Bora, 27 iv 1981 (T. Fujisawa), 2 ♂ ♂, Bora, 17 vii 1987 (SKY); *Tarama-jima* - 9 ♂ ♂ 8 ♀ ♀, 18-19 vii 1987 (SKY); *Minna-jima* - 3 ♀ ♀, 29 vi 1988 (SKY); *Taketomi-jima* - 6 ♂ ♂ 2 ♀ ♀, 24-25 vii 1987 (SKY); *Kohama-jima* - 1 ♂, 25 vii 1987 (SKY); *Kuro-shima* - 6 ♂ ♂ 1 ♀, 23-24 vii 1987 (SKY); *Iriomote-jima* - 1 ♂, 17 iv 1962 (G. Kuno), 1 ♀, 16 iv 1978 (K. Ôhara), 2 ♂ ♂, Ôhara, 23-24 v 1981 (AN), 1 ♀, same loc., 1 v 1982 (AN), 1 ♂, Toyohara, 29 iv 1982 (AN), 2 ♂ ♂, Ôhara, 25 vii 1982 (A. Matsumoto), 1 ♂ 1 ♀, Funaura, 25 vii 1982 (A. Matsumoto), 2 ♂ ♂ 1 ♀, Ôhara, 29-30 vii 1983 (AN), 1 ♂, Amitori, 5 viii 1983 (AN), 2 ♂ ♂, Ôtomi, 25 vii 1985 (AN), 1 ♂ 1 ♀, 30 vii - 1 viii 1985 (AN), 1 ♀, Ôtomi, 12 x 1987 (AN), 2 ♂ ♂, 13 x 1987 (AN); *Hateruma-jima* - 4 ♂ ♂ 4 ♀ ♀, 30 vi - 1 vii 1988 (SKY); *Yonaguni-jima* - 1 ♂, 22-24 vii 1983 (H. Kodama), 7 ♂ ♂ 1 ♀, Sonai, 5 vii 1988 (SKY).

Distribution. Amami Is. (Yoron-tô); Okinawa Is. (Okinawa-jima ?); Miyako Is. (Miyako-jima); Tarama Is. (Tarama-jima; Minna-jima); Yaeyama Is. (Ishigaki-jima after Azuma & Kinjo, 1987; Taketomi-jima; Kohama-jima; Kuro-shima; Iriomote-jima; Hateruma-jima; Yonaguni-jima). Taiwan.

Taxonomic notes. A species of "*Pachymenes*" common and widely distributed in Oriental region has been treated as *Odynerus fragilis* Smith (1857) or "*Pachymenes*" *fragilis* (Smith). Vecht (pers. comm., 1981) has examined the type of *Odynerus troglodytes* Saussure (1855) and confirmed the identity of *fragilis* with *troglodytes*. The former, therefore, must be a junior synonym of the latter. The species *troglodytes* was originally described from Senegal (Saussure, 1855, p. 249), but Vecht doubts Saussure's statement about the type locality. Meade-Waldo (1914) in his revision of the Ethiopian *Odynerus* listed *O. troglodytes* under "species unknown to the author".

Recent studies by Giordani Soika (1986) on the "*P.* *troglodytes* group revealed that at least four species are involved in it. According to him "*P.*" *yayeyamensis* belongs to this species group and is distinguished from *troglodytes* by the following male characters: clypeus more narrowly emarginate apically, with punctures much larger and denser; tergite 1 wider, with sparser punctures; tergite 2 and sternite 2 with larger and denser punctures. My study based upon more extensive material from various parts of the

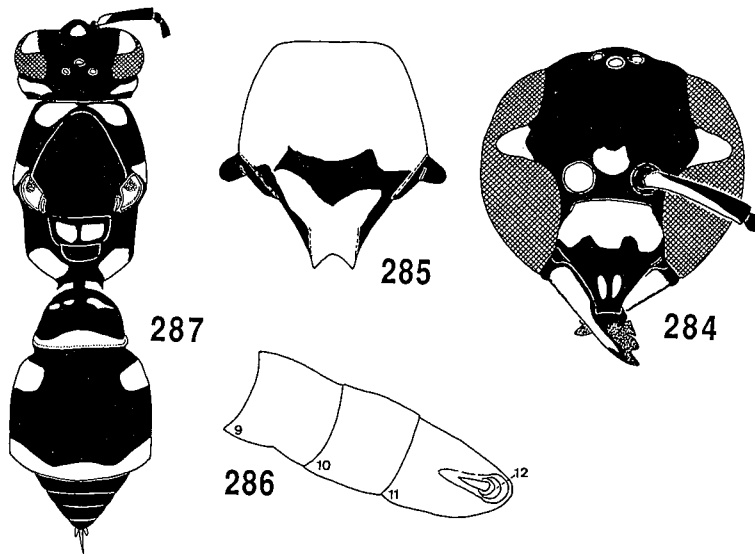

Figs. 284-287. "*Pachymenes*" *yayeyamensis*. 284, facial color pattern (♀); 285, male clypeus; 286, apical segments of male antenna; 287, body color pattern (♀).

Ryūkyū Islands supports his conclusion, and has revealed that the Taiwanese form which Sonan (1929) named *Odynerus hōkotōensis* belongs to this species.

According to Matsumura and Uchida (1926), the type locality of this species is Okinawa-hontō (=Okinawa-jima), which does not belong to the Yaeyama group. The type specimen (♂, in Coll. Entomol. Inst. Hokkaido Univ.) bears four labels: (1) on upper side, "Japan Matsumura" in print, and "SK" [S. Kiyamu?] in handwriting; on underside, "Yaeyama" in Chinese characters, and "vii[?] 0'7", both in handwriting, (2) "*Odynerus* n. sp. *yayeyamensis* in handwriting, and "det. Matsumura" in print, (3) red label, "Type Matsumura" in print, and (4) "*Pachymenes fragilis* (Smith) det. K. Yasumatsu, 1938" in handwriting. Another male specimen, believed to be the one in the type-series, bears two labels: (1) "56" in handwriting, and (2) "Okinawa S. Sakaguchi" in print. In the early 20th, to many people on the Japanese mainlands, "Okinawa" meant a district covering the Okinawa Is., Miyako Is., and Yaeyama Is., today called together "Okinawa-ken". I have not yet examined any specimen of this species from Okinawa-jima, though the species actually extends its range further north onto Yoron-tō. Thus, at present it is reasonable to regard one of the islands of the Yaeyama group as the type locality of this species.

Biology. This species nests in bamboo tubes (Y. Nakatani, pers. comm.).

Genus *Oreumenes* Bequaert

Oreumenes Bequaert, 1926, Ann. S. Afr. Mus. 23: 488 (subgenus of *Eumenes* Latreille)(type species: (*Eumenes harmandi* Pérez.) = *E. decoratus* Smith, original designation); Vecht and Fischer, 1972, Hym. Cat. (n. ed.) 8: 134 (as subgenus).

Japanese name: Suzubachi Zoku.

Bequaert (1926) gave a diagnosis for his new subgenus *Oreumenes* as follows: "Medium-sized species; mesopleura without anterior epicnemial or posterior carina. Mandibles of the usual *Eumenes* type. Vertex without hairy fovea in female. Antennae 12-segmented in female; 13-segmented in male, the last segment short, of normal shape, not forming a recurved hook. Hind margin of second abdominal tergite slightly duplicate." In addition to the peculiar condition (Fig. 290) in the terminal segment of male antenna among the species with a petiolated gastral segment 1, *Oreumenes* differs from the species of *Eumenes* (of at least Japan) in the following points: pretegular carina present, female clypeus straightly truncate apically (emarginate in the male) (Figs. 288, 289), the lateral part of pronotum separated from the dorsal part by a carina which branches off from pronotal carina, and the lateral part of propodeum rather clearly separated from the posterior face by an edge. Giordani Soika (1941), Yamane (1982) and Carpenter (1986) treated *Oreumenes* as a genus. Only one species (*O. decoratus*) occurs in Japan, Korea, Taiwan and continental China (Tosawa, 1934; Vecht & Fischer, 1972).

In the Japanese species of *Oreumenes*, *Delta*, and *Pseudozumia*, the abscissa 3 of radial vein of forewing is distinctly longer than abscissa 4, and cubital cell 3 is convex anteriorly.

Oreumenes decoratus (Smith)
(Figs. 288-291, 327)

Eumenes decoratus Smith, 1852, Trans. R. Entomol. Soc. Lond. (2)2: 36 (♀)(type loc.: Teitung, N. China); Esaki et al. 1938, Icon. Ins. Jpn. p. 360, fig. 631(1); Yano, 1950, Icon. Ins. Jpn. 2nd ed. p. 1454 (no. 4196); Ishikawa, 1965, Icon. Ins. Jpn. Col. Nat. Ed. 3: 292, pl. 246, fig. 20.

Eumenes japonicus Saussure, 1858, Rev. Mag. Zool. (2)10: 164 (♀)(type loc.: Japan); Matsumura, 1911, Thous. Ins. Jpn. Suppl. 3: 108-109, pl. 39, fig. 9; 1930, Ill. Thous. Ins. Jpn. 2: 11, pl.2, fig. 9; 1931, 6000 Ill. Ins. Jpn. p. 15 (no. 73).

Eumenes harmandi Pérez, 1905, Bull. Mus. Hist. Nat. Paris, 11: 84-85 (♀ ♂)(type loc.: central Japan); Yasumatsu, 1933, Mushi, 6: 31.

Japanese name: Suzubachi.

Diagnosis. Female and male. This species is the largest of the eumenids known from Japan proper. Body length (h+th+t1+2): 21-23 mm in ♀, 15.5-18.5 mm in ♂. Fore wing length: 18.5-20.5 mm in ♀, 15.5-16.5 mm in ♂. For the structural characteristics, see key to the Japanese genera and the diagnosis for the genus. The color pattern is relatively stable in the Japanese population. Black, with the following parts orange yellow: clypeus, a longitudinal mark between antennae (reaching downward to the upper margin of clypeus, and often pointed above), a line on the inner orbit below, a very narrow line behind eye, basal half of antennal scape below, pronotum (posterior and lower lateral portion black), tegula with a central transparent spot, parategula, a small spot under wing base (often lost), scutellar crest, metanotum posteriorly, an irregular marking along the lateral ridge of propodeum, propodeal orifice and valvae, a medially deeply incised apical band on tergite 1, a wide regular band on tergite 2 apically, a narrower apical band on sternite 2. Antenna (at least 2-3 apical segments) below, mandible in apical half, and legs extensively brownish or ferruginous in both sexes.

Material examined. Hokkaidō: 2 ♂ ♂, Hakken-zan, Sapporo, 14 vii 1978 (T. Fujisawa).

Honshū: *Iwate-ken* - 1 ♂, Jōhōji, 21 viii 1982 (HI), 1 ♀, Kanegasaki, 2 viii 1987 (SKY); *Niigata-ken* - 1 ♀, Tsubame Spa, 15 viii 1981 (KB), 1 ♂, Iwakuzure, 17 ix 1981 (KB); *Ibaraki-ken* - 1 ♀, Tsuchiura, 9 viii 1987

(SKY); *Nagano-ken* - 1 ♀, Amori, Nagano-shi, 24 viii 1979 (H. Fujisawa); *Gifu-ken* - 1 ♂, Hongô, Seki, 5 viii 1982 (Y. Takai), 2 ♂♂, same loc., 26 viii 1982 (Y. Takai).

Sado-ga-shima: 2 ♂♂ 1 ♀, Ogi, 13 vii 1980 (A. Seino), 1 ♂, Tagirisu, Mano, 23 ix 1981 (KB).

Kyûshû: *Nagasaki-ken* - 1 ♀, Haraguchi, Ômura, 17 viii 1967 (R. Ohgushi), 1 ♀, same loc., 3 ix 1967 (R. Ohgushi); *Kagoshima-ken* - 1 ♂, Kôyama, 2 vii 1978 (H. Nagase), 2 ♂♂ 1 ♀, Iriki, 3-6 ix 1984 (AN).

Tsushima Is.: *Kami-agata* - 1 ♀, Tembôdai, 19 x 1979 (T. Kumata); *Shimo-agata* - 1 ♂ 1 ♀, Izuhara (140-180 m alt.), 11 viii 1978 (K. Harusawa), 11 ♂♂ 3 ♀♀, same loc., 27 vii 1986 (K. Nakamine), 1 ♀, Tsutsu, 23 vi 1974 (I. Hiura), 1 ♀, Tatsura-yama, 29 ix 1977, 1 ♀, same loc., 23 vii 1978 (O. Tominaga).

N. Ryukyus: *Tane-ga-shima* - 1 ♂ 1 ♀, 2-4 viii 1916 (H96, H97), 1 ♀, Nakatane, 4 viii 1983 (SKY), 1 ♀, Utara, 6 viii 1986 (M. Tatsuno); *Yaku-shima* - 2 ♀♀, Kurio, 2 xi 1975 (F. Komai), 1 ♂ 2 ♀♀, Miyanoura, 8-11 viii 1981 (SKY), 1 ♂, Onoaida, 9 viii 1981 (SKY), 1 ♂, Miyanoura, 5 viii 1986 (SKY); *Kuchinoerabu-jima* - 1 ♂, Hommura, 21 vii 1989 (SKY).

S. Ryukyus: *Ishigaki-jima* - 1 ♀, Shinkawa, 7 viii 1978 (M. Terayama).

Distribution. Hokkaidô; Okushiri-tô (Munakata, 1987); Honshû; *Sado-ga-shima*; Shikoku; Kyûshû; Tsushima Is. (*Kami- & Shimo-agata*); Gotô Is. (*Fukue-jima*); Chikuzen-okino-shima; Ôsumi Is. (*Tane-ga-shima*; *Yaku-shima*; *Kuchinoerabu-jima*); Yaeyama Is. (*Ishigaki-jima*). Korea; Taiwan; continental China.

Taxonomic notes. Tosawa (1934) stated that the specimens from Taiwan, Korea and continental China examined by him agreed in coloration with Smith's original description of *Eumenes decoratus*, while those from Japan proper with Pérez's original description of *E. harmandi*. I have also found some differences between the Japanese specimens and Smith's description. For example, Smith (1852) mentioned: "... its apical margin above [apical margin of tergite 1], as well as those of the second segment, broadly, and the following segments narrowly, orange yellow" (the holotype of *E. decoratus* is a female labelled merely "N. China", though Smith gave Tein Tung as the type locality - Bequaert, 1928). Lee's (1985) description agrees in these characters (p. 93). The Japanese specimens, however, sometimes have a very narrow brownish part, but not a distinct orange band, on

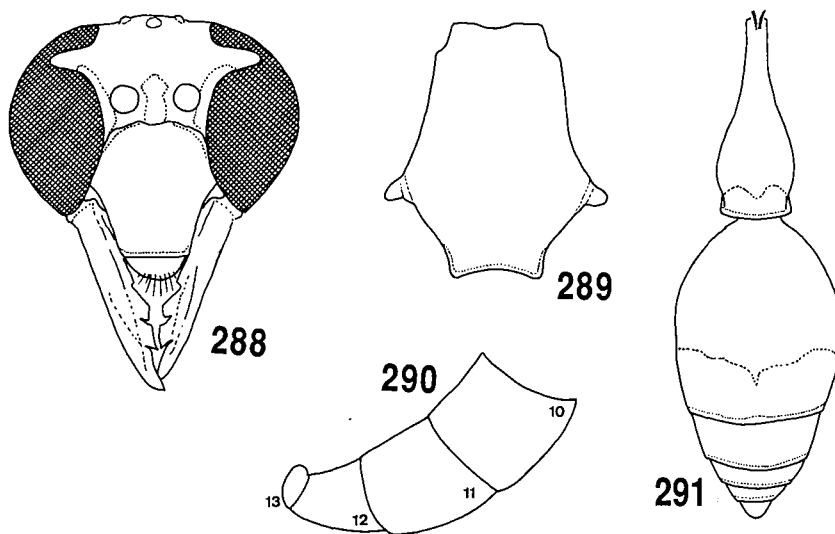

Figs. 288-291. *Oreumenes decoratus*. 288, head in frontal view (♀); 289, male clypeus; 290, apical segments of male antenna; 291, gaster from above (♀).

each of tergites 3-5 apically. Furthermore, in the Chinese specimens the pronotum seems nearly wholly orange except on the anterior vertical face, while in the Japanese ones it is marked with orange only in the anterior 2/3 of dorsal part. If these differences are constant, the Japanese population may deserve subspecific rank (in this case the name *japonicus* Saussure will be applied).

I have examined one female from Ishigaki-jima, Southern Ryukyus, kindly sent by Mr. M. Terayama. The specimen well agrees in coloration with those from the Japanese mainlands, but distinctly differs from those of Taiwan. No additional specimen has been collected on this island.

Biology. This species builds its mud nests on stones, wooden buildings, slender twigs of living trees, and tree trunks (Iwata, 1953). Several pots, quartered- or hemi-spherical in shape, are made in a cluster and the whole surface of the cluster is later covered with a thick coating of mud paste. The female wasp hunts for the larvae, relatively large in size, of geometrid moths. Tsuneki's (1980, 1982) continual observation of a second-generation female revealed that she attended her nest for more than one month, constructing a total of nine pots. Both mass and progressive provisioning were observed, and the first offspring emerged before the mother left the nest. These facts strongly suggest that this species is subsocial, though the social relation between the mother and her offspring is unclear. This species is bivoltine in at least central and southwestern Japan (Tsuneki, 1980). Additional observations were made by Katayama (1935, 1936) and Tsuneki (1978). A series of photos given by Iwata et al. (1982) illustrate the nest-building behavior.

Parasite: *Pseudoxenos iwatai* (Strepsiptera, Stylopidae). Parasitoids: *Macrosiagon nasuta*, *M. iwatai* (Coleoptera, Rhipiphoridae), *Acroricnus ambulator* (Hymenoptera, Ichneumonidae), *Stilbum cyanurum* (Chrysididae), *Amobia signata* (Diptera, Sarcophagidae) and a species of Phoridae.

Genus *Eumenes* Latreille

Eumenes Latreille, 1802, Hist. Nat. Crust. Ins. 3: 360 (type species: *Vespa coarctata* Linné, designated by Latreille, 1810).

Alpha Saussure, 1855, Et. Fam. Vesp. 3: 128, 137, pl. 7 (name for *Eumenes*, "1^{er} Division" of Saussure, 1852, p. 28) (Type species: *Vespa coarctata* Linné, designated by Bequaert, 1926).

Japanese name: Tokkuribachi Zoku.

This genus is closely related to *Oreumenes* and *Delta* (including *Phi* of authors), with which it shares the following character conditions : cephalic foveae absent, epicnemial carina absent, tegula short, parategula produced posteriorly beyond tegula, gastral tergite 1 petiolate, fore leg with a well-defined carina on its outer face, propodeal orifice with a pair of processes which can be seen when the gastral petiole is removed (Nakamine, 1987). The following characteristics are also seen in *Eumenes*: clypeus more or less emarginate at base and apex, male antenna with apically pointed hook (terminal segment), mesosoma strongly convex and subglobular, pretegular carina absent, propodeum without inferior and superior ridges, tergite 2 with a well-defined lamellate area at apical margin.

The genus is distributed all over the world. The Japanese forms have been studied by Tosawa (1934), Sonan (1939), Giordani Soika (1941, 1973, 1986), and Yamane (1977a, b). Five species (6 forms) are known to occur in Japan, one species (*punctatus*) being confined to the Tsushima Islands. Most species are confined to the Japanese mainlands and some

relatively large islands. No species are found in the Central and Southern Ryukyus despite the fact that four species occur in Taiwan. The following key is chiefly based upon Giordani Soika (1941), Sato (1964), and Yamane (1977a).

Key to the Japanese forms of *Eumenes*

1. Gastral tergite 1 relatively stumpy, seen from above two times as long as wide (at the widest part). Tergite 2 with a yellow spot on each lateral side. Apical half of femora, tibiae, and tarsi of all legs yellow or yellowish brown. Antennal hook of male recurved to approach the base of segment 10. 2
 - Gastral tergite 1 relatively slender, seen from above more than two times as long as wide. Tergite 2 usually without yellow spots (if spots present, female clypeus wholly black). Female legs largely black or blackish brown. In the male, femora below, tibiae and tarsi often yellowish, but femora above darker. Antennal hook smaller; its apex not exceeding beyond the middle of segment 10. 3
2. Larger species; body length (h+th+t1+2) more than 12 mm. Female clypeus as wide as high. Gastral sternites 4-6 with long, dense hairs in ♂. Hind trochanter and femur below with long hairs in ♂. *E. fraterculus* D.T.
 - Smaller species; body length (h+th+t1+2) less than 12 mm. Female clypeus higher than wide. Sternites 4-6 with much shorter hairs, and long hairs restricted to posterior margins in ♂. Hind trochanter and femur below with inconspicuous hairs in ♂. *E. rubrofemoratus* G.S.
3. Base of tergite 2 dorsally swollen; in profile, tergite usually meets at a right angle with sternite. Female clypeus wholly black; only rarely with a yellow marking. Male clypeus with long hairs, not shining. Male antennal segment 10 in profile wider than long; antennal hook recurved to reach segment 10. 4
 - Base of tergite 2 dorsally not swollen; in profile, the angle formed by tergite and sternite acute. Female clypeus with large yellow markings. Male clypeus with much shorter hairs, shining. Male antennal segment 10 in profile as long as wide; hook small, not reaching segment 10 *E. micado* Cam. (= *E. samuray* Schult.)
4. Tergite 2 less elongate, less gibbous at base, and without yellow spots. 5
 - Tergite 2 more elongate, more gibbous at base, and with a yellow spot on each lateral side..... *E. punctatus punctatus* Sauss.
5. Tergite 2 with dense and coarse punctation: in medio-apical part spaces between punctures usually smaller than puncture diameter. Honshū - Kyūshū and some associated islands. *E. r. rubronotatus* Pér.
 - Tergite 2 with sparser and finer punctation: in medio-apical part spaces between punctures much larger than puncture diameter. Hokkaidō. *E. r. aquilonius* Yam.

Key to the nests of Japanese *Oreumenes* and *Eumenes* excluding *E. punctatus* (adopted from Iwata, 1971, translated by Smithsonian Institution, with slight modifications)

1. A few pots are made in a cluster and the whole surface of the cluster is later covered with a thick coating of mud paste. 2

- Each pot is prepared separately and is not coated with thick mud paste..... 3
- 2. Each pot is large and quartered- or hemi-spherical in shape and the long axis is horizontal. *O. decoratus*
- Each pot is either hemispherical or subspherical and medium in size, with the mouth of the pot near the center of the spherical surface. *E. fraterculus*
- 3. The pot is always attached to the surface (flat or depressed). The hemispherical shape is the basic type and the pot is later reinforced and camouflaged with bast as the coating material. *E. rubronotatus*
- The pots may also be attached to a linear substratum. 4
- 4. The pot is placed on a flat surface or on a linear substratum. The pot is oval and medium in size and the collar is large. *E. micado*
- The pot is attached only to a linear substratum, elliptical and small in size.
..... *E. rubrofemoratus*

Eumenes fraterculus Dalla Torre
(Figs. 292, 293, 302, 307, 311, 313, 324, 329, 333)

Eumenes fraterna Smith (nec Say, 1824), 1873, Trans. R. Entomol. Soc. Lond. 1873: 195 (♀)(type loc.: "Hiogo", Honshū).

Eumenes fratercula Dalla Torre, 1894, Cat. Hym. p. 24 (new name for *E. fraterna* Smith); 1904, Gen. Ins. 19: 22 (in list); Tosawa, 1934, Trans. Kansai Entomol. Soc. 5: 13, fig. 1; Yano, 1950, Icon. Ins. Jpn. p. 1454; Ishikawa, 1965, Icon. Ins. Jpn. Col. Nat. Ed. 3: 292, pl. 146, figs. 16, 17.

Eumenes fraterculus Dalla Torre: Giordani Soika, 1941, Boll. Soc. Venez. Stor. Nat. 2: 134 (in key), 136, figs. 1(1), 3; Yamane, 1977, New Entomol. 26: 14-15, figs. 1, 5, 9, 13, 15, 20.

Eumenes pomiformis F.: Matsumura, 1911, Thous. Ins. Jpn. Suppl. 3: 110 (no. 680), pl. 39, fig. 12; 1931, 6000 Ill. Ins. Jpn. p. 16 (no. 76) (misidentification).

Japanese name: Kiboshi-tokkuribachi.

Diagnosis. Female. Body length (h+th+t1+2): 12.0-16.0 mm. Fore wing length: 10.0-13.0 mm. Head wider than high, densely punctate, with long hairs on frons and vertex. Clypeus nearly as wide as high (Fig. 292), weakly punctate. Thorax and propodeum densely punctate, with long hairs; punctation on scutellum and metanotum coarse. Gastral tergite 1 densely punctate; punctation finer than on thorax. Tergite 2 densely punctate; punctures become coarser toward apex. Hairs on gastral tergite 1 long; those on other segments much shorter.

Black, with the following parts yellow: a wide basal band on clypeus (Fig. 292), an interantennal mark not reaching the base of clypeus (Fig. 307), antennal scape below, a band on pronotum anteriorly, a spot under wing base, tegula with a brownish median part, a pair of spots on scutellum, metanotum largely, a spot on each side of propodeum near base, a pair of small spots on tergite 1 (often lost), a pair of larger spots on tergite 2, apical bands on tergites 1-4 (band on t2 widest) and sternite 2, and legs extensively.

Male. Body length (h+th+t1+2): 10.5-14.0 mm. Fore wing length: 9.0-11.0 mm. Similar to the female in both structure and coloration. Clypeus distinctly higher than wide (Fig. 293), basally with relatively long hairs. Gastral sternites 4-6 with long hairs densely (Fig. 324). Trochanter and femur of hind leg below with long hairs (Fig. 311). Clypeus usually wholly yellow. Interantennal bar usually reaching the base of clypeus. Antennal hook large, almost reaching the base of segment 10 (Fig. 302).

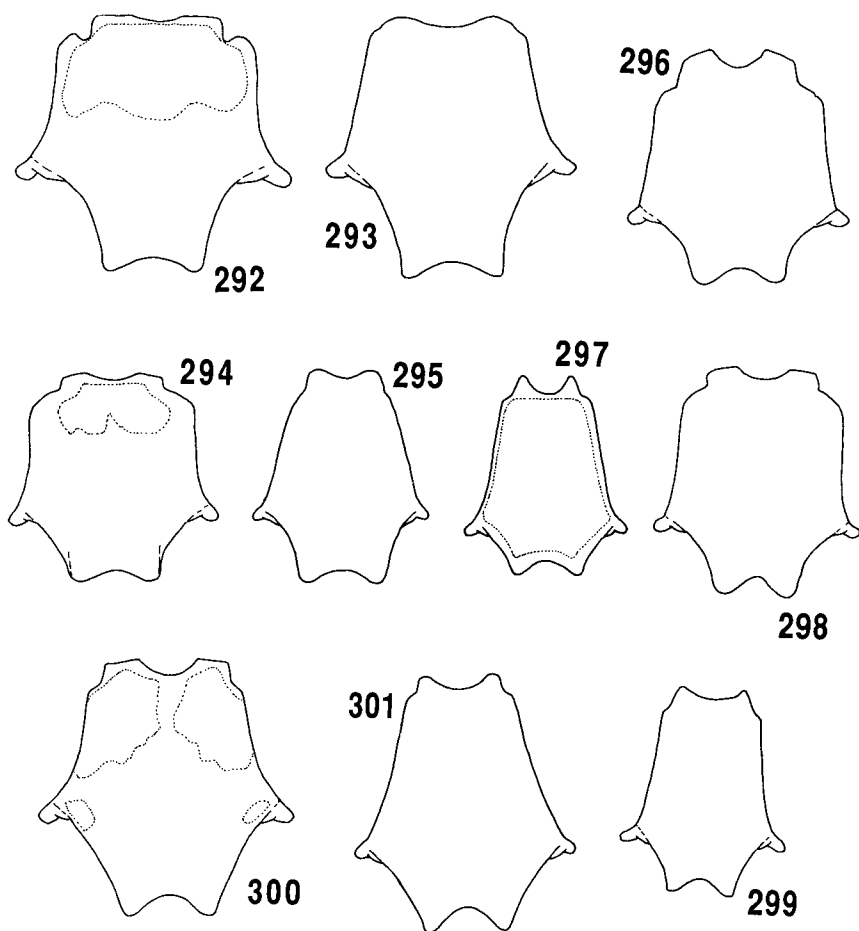

Figs. 292-301. Clypeus of Japanese *Eumenes*. 292, *fraterculus* ♀; 293, ditto ♂; 294, *rubrofemoratus* ♀; 295, ditto ♂; 296, *rubronotatus* ♀; 297, ditto ♂; 298, *punctatus* ♀; 299, ditto ♂; 300, *micado* ♀; 301, ditto ♂.

Material examined. Honshû: *Niigata-ken* - 2 ♀, *Fukushima-gata*, 2 x 1977 (HI), 1 ♀, same loc., 21 ix 1980 (HI); *Fukui-ken* - 1 ♀, Sanri-hama, 22 v 1971 (TT), 1 ♂ 1 ♀, Ôno, 27 vi 1973 (TT); *Hyôgo-ken* - 1 ♀, Sasayama, Tamba, 21 vii 1952 (K. Iwata), 1 ♂, Miki, 1 v 1968 (K. Iwata).

Shikoku: *Kôchi-ken* - 1 ♂, Okoyama, Nankoku, 2 vii 1975 (SI), 1 ♀, Godaisan, Kôchi-shi, 27 v 1976 (SI).

Kyûshû: *Nagasaki-ken* - 1 ♀, Haraguchi, Ômura, 18 v 1967 (R. Ohgushi); *Kagoshima-ken* - 1 ♀, Kanoya, 8 ix 1981 (SI), 1 ♀, Ibusuki, 16 x 1988 (SKY).

Distribution. Honshû; Shikoku; Kyûshû; Gotô Is. (Fukue-jima). E. Siberia (Kurzenko, 1984a).

Biology. This species is widely distributed on the mainlands of Japan except Hokkaidô. Though it was common when Iwata (1953) studied its biology, recent collection efforts show that it has become much rarer probably due to the deterioration in rural environments. This species is bivoltine and builds mud nests among the foliage of trees or

bushes, attaching them to plant stems, in summer, but it prefers sunny stone surfaces in late fall (Fig. 333). A few pots are made in a cluster and the whole surface of the cluster is later covered with a thick coating of mud paste; each pot is either hemispherical or subspherical, with the mouth near the center of the spherical surface. Four to 16 caterpillars chiefly of noctuid moths are stored in a cell (Iwata, 1953, 1978a, 1980b; also see Masuda, 1941). Nesting behavior is illustrated by color photos in Iwata et al. (1982).

Parasitoids: *Acroicnus ambulator* (Hymenoptera, Ichneumonidae), *Chrysis apicata* (Hymenoptera, Chrysididae), *Amobia signata* (Diptera, Sarcophagidae), *Macrosiagon nasuta* and *M. iwatai* (Coleoptera, Rhipiphoridae). For the biology of *M. nasuta*, see also Iwata (1939c).

Eumenes rubrofemoratus Giordani Soika
(Figs. 294, 295, 303, 312, 325, 330, 334)

"*Eumenes rubrofemoratus* Pérez": Tosawa, 1934, Trans. Kansai Entomol. Soc. 5: 4 (key), 7, pl. 1, fig. 7 (lapsus for *E. rubronotatus* Pérez).

Eumenes rubrofemoratus (Tos.) n. sp.: Giordani Soika, 1941, Boll. Soc. Venez. Stor. Nat. 2: 135, 145, fig. 1 (9, 10) (♀ ♂)(type loc.: Japan).

Eumenes rubrofemoratus Tosawa: Ishikawa, 1965, Icon. Ins. Jpn. Col. Nat. Ed. 3: 292.

Eumenes rubrofemoratus Giordani Soika: Vecht and Fischer, 1972, Hym. Cat. (n. ed.) 8: 132; Yamane, 1977, New Entomol. 26: 15-16, figs. 2, 6, 14, 21; Giordani Soika, 1986, Boll. Mus. Civ. Stor. Nat. Venez. 35: 156.

Japanese name: Kiashi-tokkuribachi.

Diagnosis. Female and male. Body length (h+th+t1+2): 10.0-11.5 mm in ♀, 9.0-10.0 mm in ♂. Fore wing length: 9.0-9.5 mm in ♀, ca. 8 mm in ♂. Similar to *E. fraterculus*, but differs from the latter in the following points: much smaller, body length less than 12 mm; female clypeus higher than wide (Fig. 294); emarginated part of male clypeus slightly wider than the base of clypeus (Fig. 295); antennal hook relatively short, with short hairs on its inner face (Fig. 303); gastral sternites 4-6 of the male with much shorter hairs, and long hairs confined to posterior margins (Fig. 325); hind trochanter and femur of the male below with inconspicuous hairs (Fig. 312); female antenna below sometimes extensively yellowish brown or ferruginous; yellow spots on scutellum always lost.

Material examined. Honshū: *Iwate-ken* - 1 ♀, Takizawa, 20 ix 1979 (YM); *Niigata-ken* - 1 ♀, Shidai-hama, 29 ix 1974 (HI); *Fukui-ken* - 1 ♂, Sanri-hama, 30 v 1973 (TT), 1 ♀, same loc., 20 vi 1976 (H. Kurokawa); *Yamaguchi-ken* - 1 ♀, Bōfu, 29 vi 1976 (reared by S. Nagai); *Hyōgo-ken* - 1 ♀, Sasayama, Tamba, 21 ix 1952 (K. Iwata); *Okayama-ken* - 1 ♂, Nonoguchi, 16 vii 1960 (R. Momoi).

Kyūshū: *Nagasaki-ken* - 1 ♂, Haraguchi, Ōmura, 9 x 1966 (R. Ohgushi), 1 ♀, same loc., 5 xi 1966 (R. Ohgushi).

Distribution. Honshū; Shikoku; Kyūshū.

Biology. Like the preceding species, *E. rubrofemoratus* was common in rural areas of southwestern Japan during the first half of 1900s. Now it may be the rarest of the five Japanese *Eumenes* species, though rather common in the Kantō District, Honshū (Hisamatsu et al., 1986). Tsuneki (1929) and Iwata (1953) studied the biology of this species. Two generations occur in a year. The female wasp builds her nest on dry stems of herbs (mainly *Rumex*) in the grass from late spring to summer, while on stems or blades of small gramineous plants quite near the ground in late fall (Fig. 334). The elliptical pots are prepared separately, not coated with thick mud paste, and always attached to a linear substrate. Many horny projections are occasionally built on mud surface. Larvae of

various moths (Geometridae; Pyralidae; Olethreutidae) are captured for the young.

Parasite: *Pseudoxenos iwatai* (Strepsiptera, Stylopidae). Parasitoids: *Acroricnus ambulator*, *Chrysis cyanurum*, *Amobia signata* and *Macrosiagon nasuta*.

Eumenes rubronotatus Pérez
(Figs. 296, 297, 304, 308, 309, 314, 316, 319-321, 328, 335)

Eumenes rubronotatus Pérez, 1905, Bull. Mus. Hist. Nat. Paris, 11: 85 (♂)(type loc.: Yokohama, Honshû).

Eumenes dimidiaticlypeus Giordani Soika, 1973, Boll. Mus. Civ. Stor. Nat. Venez. 24: 127-129 (♀)(Type loc.: Tôkyô).

Japanese names: Mumon-tokkuribachi (Samurai-tokkuribachi).

Diagnosis. Body length (h+th+t1+2): 10.0-13.0 mm in ♀, 8.0-11.0 mm in ♂. Fore wing length: 10.0-11.5 mm in ♀, 8.0-9.0 mm in ♂. The following character conditions separate this species from the other Japanese congeners: head distinctly wider than high; female clypeus higher than wide, without yellow marking (Fig. 296); male clypeus with relatively long hairs, punctate, not shining; antennal hook medium in size, reaching the middle of segment 10 (Fig. 304); in profile the tergite meets sternite at a right angle at the base of gastral segment 2 (Fig. 316); tergites 1 and 2 coarsely and densely punctate; tergite 2 usually without yellow spots; sternite 2 finely and sparsely punctate; on other tergites and sternites punctation much finer.

This is the most common species of the Japanese *Eumenes*, and occurs even on some small islands such as Kuro-shima and Kuchinoerabu-jima in the N. Ryukyus.

Eumenes rubronotatus rubronotatus Pérez
(Figs. 297, 308, 309, 320, 321, 328, 335)

Eumenes rubronotatus; Giordani Soika, 1941, Boll. Soc. Venez. Stor. Nat. 2: 132 (in key), 144, figs 1(8, 10), 2(6); Yamane, 1977, New Entomol. 26: 16-17, figs. 3, 7, 10, 16, 18; Giordani Soika, 1986, Boll. Mus. Civ. Stor. Nat. Venez. 35: 156.

Eumenes architectus Smith: Tosawa, 1934, Trans. Kansai Entomol. Soc. 5: 6-7, fig. 8 (misidentification).

Eumenes samuray Schulthess: Ishikawa, 1965, Icon. Ins. Jpn. Col. Nat. Ed. 3: 292 (no. 19), pl. 146, fig. 9 (misidentification).

Japanese name: Mumon-tokkuribachi.

Diagnosis. Body black, with the following parts yellow: male clypeus almost wholly (Fig. 297; sometimes with irregular black markings; female clypeus usually wholly black, but very rarely with yellow spots), interantennal bar approaching close to the base of clypeus in the female (Fig. 309), a line behind eye, anterior band on pronotum (much reduced in the male), spot under wing base, a spot on tegula posteriorly, metanotum (in the male often wholly black), a narrow apical band on tergite 1 (medially concave), a relatively wide band on tergite 2 (medially narrowed), a narrow apical band on sternite 2. Scutellum never marked with yellow. Tergite 2 very rarely with a yellow spot on each side.

Material examined. Honshû: *Iwate-ken* - 1 ♀, Kuriyagawa, Morioka, 7 ix 1970 (YM), 1 ♂, Ashiro, 22 ix 1974 (YM), 1 ♀, Takizawa, 26 ix 1976 (YM & T. Matsumura), 1 ♀, Ôshuku, Shizukuishi, 7 viii 1987 (SKY);

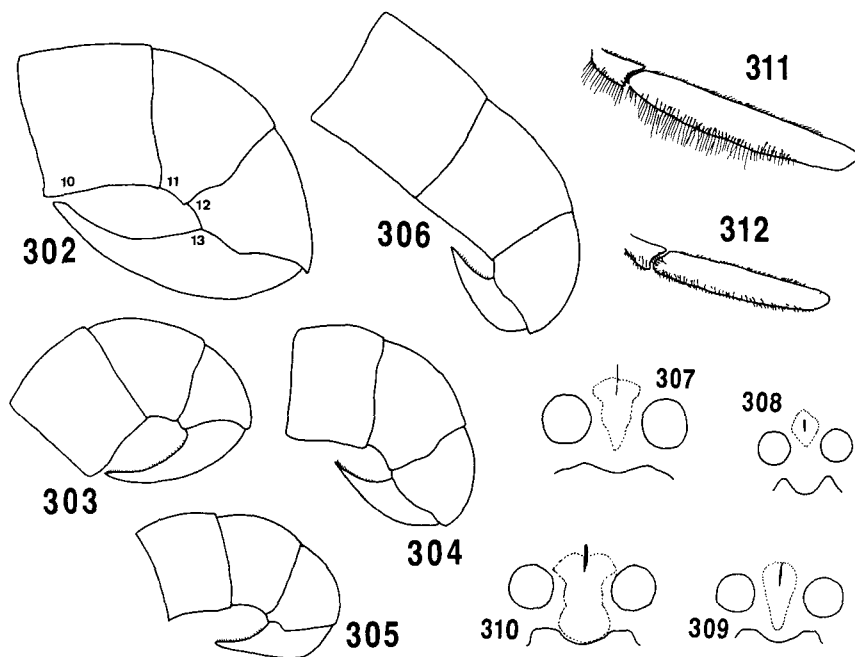

Figs. 302-306. Segments 10-13 of male antenna in Japanese *Eumenes* (305, original; others, after Yamane, 1977a). 302, *fraterculus*; 303, *rubrofemoratus*; 304, *rubronotatus*; 305, *punctatus*; 306, *micado*.
 Figs. 307-310. Interantennal marking (after Yamane, 1977a). 307, *fraterculus* ♀; 308, *rubronotatus* ♂; 309, ditto ♀; 310, *micado* ♀.
 Figs. 311, 312. Hind trochanter and femur (♂) (after Yamane, 1977a). 311, *fraterculus*; 312, *rubrofemoratus*.

Yamagata-ken - 1 ♂, Chôjagahara, Oguni, 22 vi 1979; *Fukushima-ken* - 1 ♀, Mishima, 24 vi 1980 (HI); *Niigata-ken* - 1 ♂, Muroya, Mikawa, 21 viii 1977 (HI), 1 ♂, Kami-ishikawa, Shibata, 12 viii 1979 (HI), 1 ♂1 ♀, Shiori Pass (1000 m alt.), Komaga-take, 1 ix 1979 (HI), 1 ♀, Senami, 3 vii 1980 (KB), 1 ♂, same loc., 20 vi 1981 (KB), 1 ♀, same loc., 17 vii 1981 (KB), 1 ♂, same loc., 30 vii 1981 (KB), 1 ♀, same loc., 28 viii 1981 (KB), 1 ♂, same loc., 3 ix 1981 (KB), 1 ♂1 ♀, Iwakuzure, 17 ix 1981 (KB); *Ibaraki-ken* - 1 ♂, Tsuchiura, 9 viii 1987 (SKY); *Saitama-ken* - 1 ♂, Ageo, 23 vii 1983 (T. Sunose); *Nagano-ken* - 1 ♀, Yokoyama, Ina, 17 ix 1961 (YM), 1 ♀, Habiro, Ina, 27 viii 1962 (YM), 1 ♂, Yokoyama, Ina, 31 viii 1962 (YM); *Gifu-ken* - 1 ♂3 ♀ ♀, Horado, 7 viii 1982 (Y. Takai), 1 ♀, Hongô-chô, Seki, 11 viii 1982 (Y. Takai), 1 ♀, Tônohora, Seki, 2 viii 1982 (Y. Takai); *Aichi-ken* - 5 ♀ ♀, Jôkôji, 3 x 1976 (YM); *Wakayama-ken* - 1 ♂, Koza, 25 ix 1974 (S. Takagi); *Shimane-ken* - 1 ♀, Sakane, Izumo, 7 x 1976 (T. Sunose); *Tottori-ken* - 1 ♀, Mt. Daisen, 31 x 1961 (H. Fujii).

Sado-ga-shima: 1 ♀, Kobayashi, 23-5 x 1976 (A. Seino).

Oki Is.: *Nishi-no-shima* - 1 ♀, Urago, 11 v 1982 (YM).

Shikoku: *Kôchi-ken* - 1 ♂, Monobe, Nankoku, 9 v 1974 (SI), 1 ♀, Godaisan, Kôchi-shi, 7 v 1975 (SI), 1 ♂, same loc., 22 v 1975 (SI), 1 ♀, Monobe, Nankoku, 24 vii 1975 (SI).

Kyûshû: *Fukuoka-ken* - 2 ♀ ♀, Hakozaki, Fukuoka-shi, 18 ix 1958 (YM), 1 ♂1 ♀, same loc., 2 vii 1959 (YM), 1 ♂, Kashii, 16 ix 1959 (YM), 1 ♀, Mii-machi, Kurume, 2 vi 1960 (YM); *Nagasaki-ken* - 1 ♀, Haraguchi, Ômura, 5 vi 1966 (R. Ohgushi), 1 ♂, same loc., 26 viii 1966 (R. Ohgushi); *Kumamoto-ken* - 1 ♀, Toyo-mura, 8 viii 1983 (M. Maeda); *Kagoshima-ken* - 1 ♀, Osaki, Kagoshima-shi, 4 x 1977 (H. Nagase), 1 ♂, Uchinoura, 16 x 1977 (H. Nagase), 1 ♂, Kôyama, 2 vii 1978 (H. Nagase), 1 ♂, Shiroyama, Kagoshima-shi, 4 vii 1981 (SKY), 1

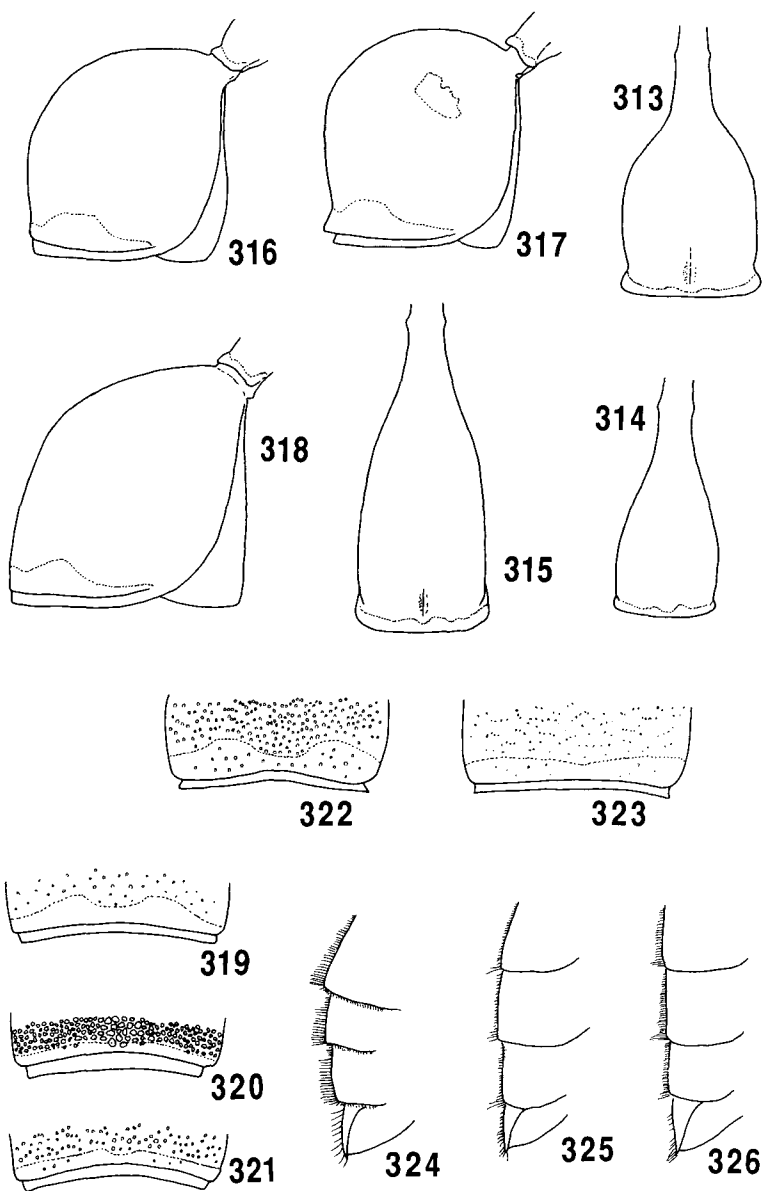

Figs. 313-315. Gastral tergite 1 from above in Japanese *Eumenes*. 313, *fraterculus*; 314, *rubronotatus*; 315, *micado*.

Figs. 316-318. Gastral segment 2 in profile (316, original; others, after Yamane 1977a). 316, *rubronotatus*; 317, *punctatus*; 318, *micado*.

Figs. 319-323. Apical part of gastral tergite 2 from above (after Yamane, 1977a,b). 319, *rubronotatus aquilonius*; 320, *r. rubronotatus* (typical); 321, ditto (rare condition); 322, *micado* (*samuray*-type); 323, ditto (*micado*-type).

Figs. 324-326. Male gastral sternites in profile (after Yamane, 1977a). 324, *fraterculus*; 325, *rubrofemoratus*; 326, *micado*.

♂, same loc., 10 vii 1981 (SKY), 1 ♀, Kirishima-jingû, 23 vii 1981 (SKY), 4 ♂♂, Shiroyama, Kagoshima-shi, 30 vii 1981 (SKY), 7 ♂♂ 1 ♀, Kôrimoto, Kagoshima-shi, 7 viii 1981 (SKY), 1 ♂, same loc., 17 viii 1981 (SKY), 1 ♂, Meiwa, Kagoshima-shi, 15 viii 1981 (SKY), 2 ♂♂, Irino, Ei, 11 ix 1983 (M. Ôhara), 2 ♂♂, Haruyama, Kagoshima-shi, 11 ix 1983 (M. Ôhara), 1 ♀, Nagashiro-bokujô, 20 v 1984 (M. Ôhara), 1 ♂, Eboshi-dake, 25 vii 1984 (AN), 1 ♀, Takeyama nr Yamakawa, 6 viii 1984 (M. Maegata), 1 ♀, Iriki, 5 ix 1984 (AN), 1 ♂, Kaimon-dake, 26 viii 1986 (SKY), 1 ♀, Shiroyama, Kagoshima-shi, 20 ix 1987 (SKY).

Islands located close to Kagashima-ken-hondo: *Akune-ôshima* - 3 ♀♀, 5 viii 1983 (SKY); *Naga-shima* - 4 ♂♂, 27 viii 1984 (SKY); *Take-shima* (nr Naga-shima) - 1 ♂, 28 viii 1984 (SKY); *Kamikoshiki-jima* - 1 ♂, 5 ix 1984 (M. Maegata).

N. Ryukyus: *Kuro-shima* - 24 ♂♂ 11 ♀♀, Ôsato, 29 viii-4 ix 1981 (SKY); *Tane-ga-shima* - 1 ♀, Hirayama, 9 viii 1916 (H114), 1 ♀, Nishino-omote, 31 vii 1982 (KT), 2 ♂♂ 2 ♀♀, Hamada, 1-2 viii 1984 (SKY), 1 ♂, Ikeno, 21 vii 1984 (S. Watahiki); *Mage-shima* - 1 ♂, 22 vii 1984 (S. Watahiki); *Yaku-shima* - 1 ♂ 4 ♀♀, Miyanoura, 8-11 viii 1981 (SKY), 2 ♂♂, Kusugawa, 9 viii 1981 (SKY), 1 ♀, Onoaida, 9 viii 1981 (SKY), 1 ♀, Shitogo, 10 viii 1981 (SKY), 3 ♂♂ 1 ♀, Onoaida (40-200 m alt.), 27-9 vi 1982 (SI), 1 ♂ 1 ♀, Miyanoura (0-60 m alt.), 26-8 vi 1982 (SI); *Kuchinoerabu-jima* - 1 ♀, Hommura, 18 v 1989 (H. Watanabe); 1 ♂ 1 ♀, Shin-dake, 21 vii 1979 (H. Watanabe).

Distribution. Honshû; Sado-ga-shima; Oki Is. (Nishino-shima); Shikoku; Kyûshû; Goshoura-jima; Akune-ôshima; Naga-shima; Take-shima (nr Naga-shima); Kamikoshiki-jima; Ôsumi Is. (Kuro-shima; Tane-ga-shima; Mage-shima; Yaku-shima; Kuchinoerabu-jima). Korea (new record); China (Kwantung).

Biology. The biology of this form has been studied by Iwata (1953) and reviewed in Iwata (1971, 1978a, 1980b). Unfortunately Iwata (1953, 1971) used the incorrect name (*E. samuray* Schulthess) for this species, and Vecht and Fischer (1972) cited his record without correction. His misapplication may have been based upon Yasumatsu's misidentification. Later, Iwata (1980b) used the correct Japanese name "Mumon-tokkuribachi", with no scientific name, instead of "Samurai-tokkuribachi" erroneously applied in his earlier publications.

This species flies from early May to mid October, and is probably bivoltine. Female wasps build their nests on the stone surface, especially in depressions (Fig. 335). The pots, hemispherical in shape, are prepared separately and not coated with thick mud paste. It is later reinforced and camouflaged with bast as the coating material. The greater part of the prey consists of larvae of *Gelasma illitirata* Walker (Geometridae); when they are scarce, caterpillars of other geometrids are also hunted.

Parasitoids: *Acroicnus ambulator*, *Chrysis* sp. and *Amobia signata*.

Eumenes rubronotatus aquilonius Sk. Yamane
(Figs. 319, 328)

Eumenes rubronotatus aquilonius Yamane, 1977, New Entomol. 26: 59-61, figs. 1, 2, 5, 8 (♀♂)(type loc.: Sapporo, Hokkaidô).

Diagnosis. This subspecies differs from the nominotypical subspecies in the following points: body slightly smaller; gastral tergite 2 very feebly and sparsely punctate, polished; spaces between punctures distinctly larger than puncture diameter (Fig. 319); sternite 2 almost impunctate; male clypeus black, with an irregular yellow marking; anterior band on pronotum reduced, sometimes lost.

Material examined. Hokkaidô: 1 ♀, Sapporo, 22 vi 1924 (H. Kôno), 1 ♂ 1 ♀, Jôzankei, Sapporo, 16 vii 1926 (S. Matsumura) (holotype), 1 ♀, Maruyama, Sapporo, 19 vii 1928 (T. Uchida), 1 ♀, Sapporo, 25 viii 1935 (Y. Sugihara), 1 ♂, same loc., 21 vi 1953 (C. Watanabe), 1 ♂, Otarunai near Sapporo, 14 ix 1968 (SY), 1 ♀, Heiwa, Sapporo, 26 viii 1974 (SKY).

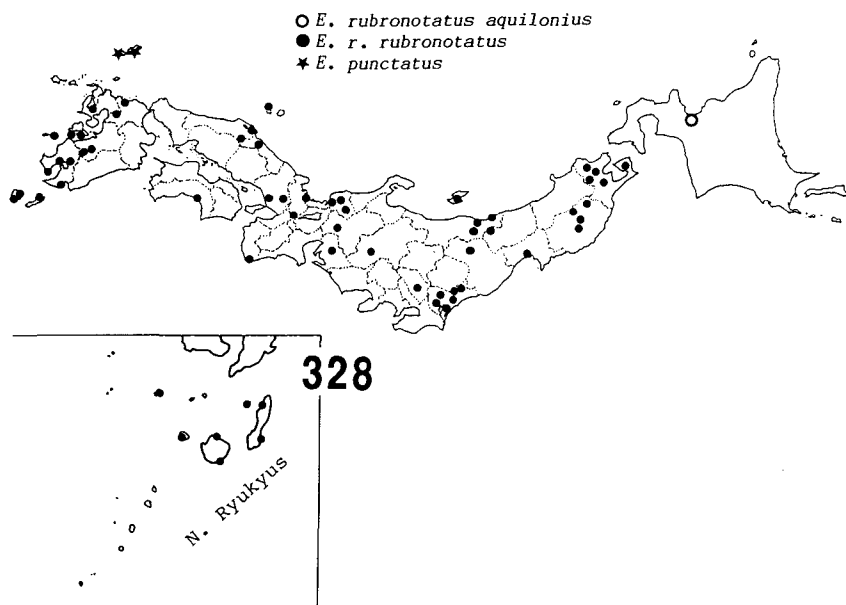
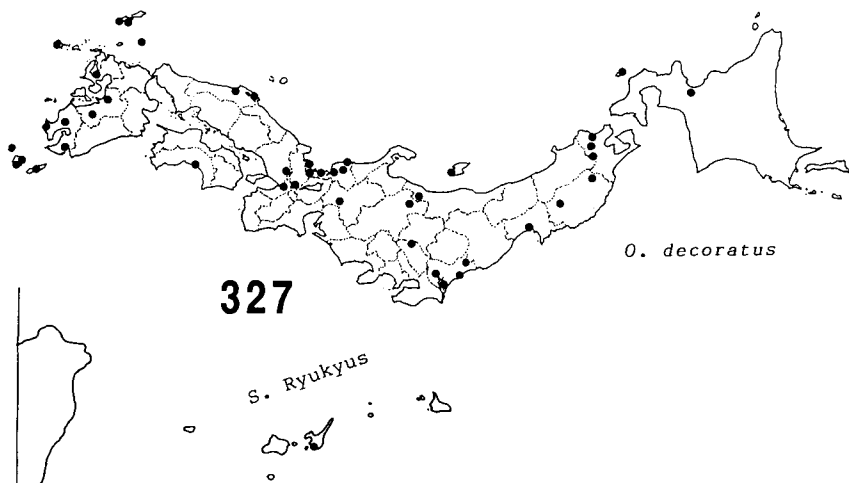

Figs. 327, 328. Distribution of *Oreumenes decoratus* and two *Eumenes* species in Japan.

Distribution. Hokkaidô.

Biology. No information is available. The collection records suggest that this form is bivoltine.

Eumenes punctatus punctatus Saussure
(Figs. 298, 299, 305, 317, 328)

Eumenes punctatus Saussure, 1852, Et. Fam. Vesp. 1: 37 (♀ ♂)(type loc.: China); Giordani Soika, 1941, Boll. Soc. Venez. Stor. Nat. 2: 132 (in key), 142-143, figs. 1(7), 2(5); 1976, Ann. Hist.-Nat. Mus. Hung. 68: 295 (from Korea).

Eumenes architectus Smith: Yasumatsu, 1936, Insects of Jehol, 7 (Eumenidae): 1-3, 10-12, pl. 1, fig. 1 (from Manchoukuo; misidentification).

Eumenes punctatus punctatus Saussure: Yamane, 1977, New Entomol. 26: 61 (from Korea).

Japanese name: Tairiku-tokkuribachi.

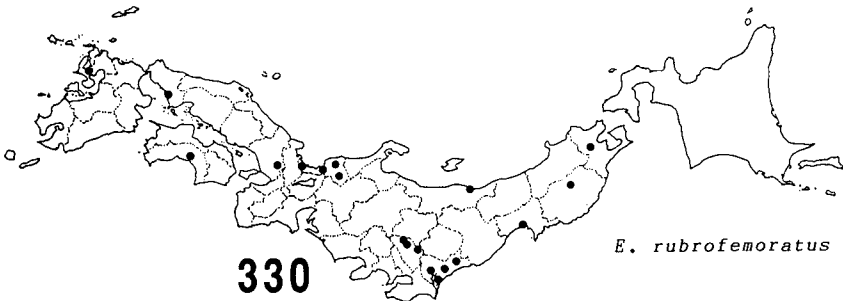
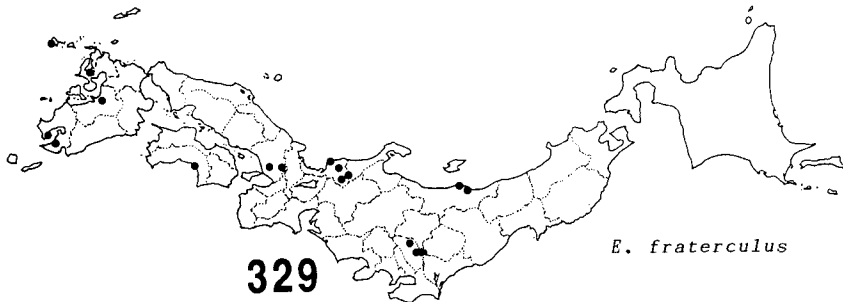

Figs. 329-331. Distribution of three *Eumenes* species in Japan.

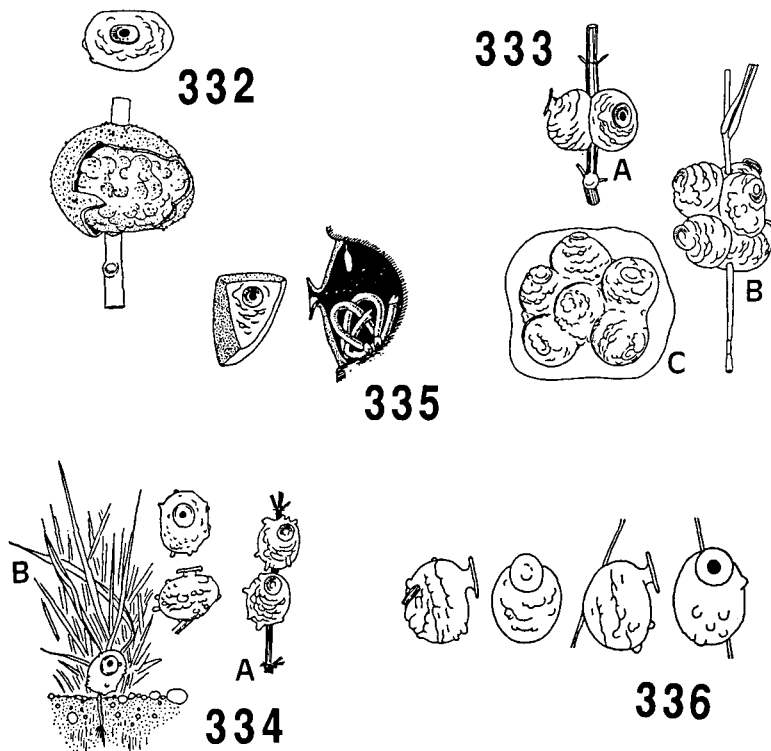

Figs. 332-336. Nests of Japanese *Oreumenes* and *Eumenes* (after Iwata, 1980c). 332, *O. decoratus*; 333, *E. fraterculus* (A,B, summer nest; C, fall nest); 334, *E. rubrofemoratus* (A, summer nest; B, fall nest); 335, *E. rubronotatus* (left, pot made in a stone depression; right, section of a nest); 336, *E. micado*.

Diagnosis. Female and male. Body length (h+th+t1+2): 11.0-13.0 mm in ♀, 10.0-11.0 mm in ♂. Fore wing length: 10.0-11.5 mm in ♀, 8.5-9.0 mm in ♂. Good descriptions are given in Yasumatsu (1936) and Giordani Soika (1941). Here, important character conditions useful in separating this form from the closely related *E. rubronotatus* will be given. Head, thorax and propodeum much more finely and densely punctate; spaces between punctures not forming carinae. Clypeus more shallowly emarginate at base and more deeply at apex in both sexes (Figs. 298, 299). Punctuation on gastral tergites 1 and 2 also much finer. Propodeal groove less developed, almost absent near the base. Tergite 2 more swollen dorsally, preapical depression more pronounced (Fig. 317).

Tergite 2 almost always with a yellow marking on each side (Fig. 317) (Korean specimens often lacking the spots). Female legs black, but orange or ferruginous parts more extensive: fore femur apically, outer face of fore tibia in apical 1/3, mid and hind tibiae in basal half marked with these colors. Fore and mid tibiae of male legs yellowish on outer face; tarsi extensively ferruginous.

Material examined. Tsushima Is.: *Kami-agata* - 2 ♀♀, Sasuna - Nembutsu-zaka, 22 x 1975 (I. Hiura), 1 ♂, Sasuna, 17 ix 1977 (Tominaga), 2 ♀♀, Shiohama, Nii, 24 viii 1979 (I. Hiura), 1 ♀, Oboshi-yama, 24 viii 1979 (A. Seino); *Shimo-agata* - 1 ♂ 1 ♀, Tsutsu, 6 viii 1967 (YH), 1 ♀, Banshojin, Izuhara, 18 viii 1968 (K. Tani), 1 ♂,

Tsutsu-misaki, 22 viii 1979 (I. Hiura).

Distribution. Tsushima Is. (Kami-agata; Shimo-agata). Korea; China. "*E. fratercula*" recorded from Izuhara, Asamo and Uchiyama (Tsushima Is.) by Tano (1966) is *E. punctatus* (I have examined the female from Tano's collection).

Taxonomic notes. In Japan this form may easily be distinguished from the allopatric *E. r. rubronotatus* according to localities. In Korea, however, where these species seem completely sympatric, separation of them is rather difficult. *E. punctatus* often lacks yellow gastral spots, and punctation is intermediate in size and condition between the Japanese populations of *E. punctatus* and *E. rubronotatus*. The following character conditions may be useful in separating *E. punctatus* from *E. rubronotatus* in Korea: propodeal groove shallower, almost absent near the base of propodeum (in *rubronotatus* the groove is more distinct and discernible over the whole length of propodeum); tegula yellow with the basal area blackish and with a brownish median spot (in *rubronotatus* the tegula almost wholly blackish); metanotum usually with a yellow band (in *rubronotatus* the band very often lost); tibiae of all legs in the female usually brownish (in *rubronotatus* legs darker); tibiae of all legs in the male extensively yellow (in *rubronotatus* legs much darker, at least hind tibia wholly blackish); male clypeus relatively elongate.

Biology. Nothing is known in Japan.

Eumenes micado Cameron

(Figs. 300, 301, 306, 310, 315, 318, 322, 323, 326, 331, 336)

Eumenes micado Cameron, 1904, Entomologist 37: 35 (♀) (type loc.: "Sharo-kowa", Japan); Bequaert, 1928, Ann. Mag. Nat. Hist. 10(2): 161; Tosawa, 1934, Trans. Kansai Entomol. Soc. 5: 5 (in key), 11, pl. 2, fig. 2 (*E. mikado* (!)); Giordani Soika, 1941, Boll. Soc. Venez. Stor. Nat. 2: 135 (in key), 137, figs. 1(2), 2(1, 8); Yano, 1950, Icon. Ins. Jpn. 2nd ed. p. 1454 (no. 4195); Ishikawa, 1965, Icon. Ins. Jpn. Col. Nat. Ed. 3: 292, pl. 146, fig. 18; Yamane, 1977, New Entomol. 26: 49, figs. 4, 8, 12, 17, 19, 22, 24.

Eumenes samuray Schulthess, 1908, Mitt. Schweiz. Entomol. Ges. 11: 284 (♂♀)(type loc.: Yokohama (?); Nagasaki); Giordani Soika, 1941, Boll. Soc. Venez. Stor. Nat. 2: 135 (*samurayi* (!), in key), 137, fig. 2(7); Yamane, 1977, New Entomol. 26: 49, fig. 23.

Eumenes samurayi (!) *rufescens* Giordani Soika, 1973, Boll. Mus. Civ. Stor. Nat. Venezia, 24: 127 (♂)(type loc.: Tôkyô). Syn. nov.

Japanese names: Mikado-tokkuribachi (Samurai-tokkuribachi).

Diagnosis. Female. Body length (h+th+t1+2): 13.0-15.0 mm. Fore wing length: 10.5-12.0 mm. Head distinctly wider than high, densely punctate; punctation on gena sparser. Hairs on frons and vertex long. Clypeus higher than wide (Fig. 300), with shorter hairs; punctures sparser and shallower than those on frons. Alitrunk longer than wide, densely punctate, with long hairs. Metapleuron almost impunctate. Propodeum with shallow vertical groove. Gastral petiole coarsely and densely punctate, nearly as long as tergite 2. In profile the angle formed by tergite and sternite at the base of segment 2 less than 90° (Fig. 318). Punctation on tergite 2 much finer than on petiole (in the spring specimens punctation still finer and sparser, and in the Hokkaidô population even the summer individuals show such a tendency). Sternite 2 shining, with very sparse, superficial punctures. Other tergites and sternites with micropunctures alone.

Black, with the following parts yellow or orange: paired elongate markings at the base of clypeus (sometimes clypeus basally extensively yellow), a pair of smaller spots

below the elongate markings (often lost) (Fig. 300), interantennal bar (Fig. 310), narrow short line behind eye, pronotum anteriorly, a pair of comma-shaped markings on mesoscutum anteriorly (often lost), a large spot under wing base, tegula with a median blackish spot, a pair of square markings on scutellum, metanotum largely, a pair of irregular markings on propodeum (often lost), narrow apical band on tergite 1, relatively wide apical band on tergite 2 (medially narrowed), a small spot on each side of tergite 2 (only rarely seen), narrow apical band on sternite 2, outer face of mid coxa, apical part of femora of all legs. Two or three apical segments of antenna below ferruginous. Tibiae and tarsi of all legs ferruginous to a varying degree.

Male. Length (h+th+t1+2) 11.5-14.0 mm. Fore wing length 9.5-11.0 mm. Much as in the female. Antennal hook ferruginous in color, small, not reaching the apex of segment 10 (Fig. 306). Clypeus wholly yellow. Antennal scape (at least basal part) below yellow. Mesoscutum usually wholly black. Yellow markings on scutellum much reduced, often lost. Propodeum usually without markings. Apical band on sternite 2 wider than in the female, with a pair of distinct projections. Legs more extensively marked with yellow.

Material examined. Hokkaidô: 1♂, Maruyama, Sapporo, 29 viii 1926 (T. Uchida).

Honshû: *Iwate-ken* - 1♀, Kuriyagawa, Morioka, 25 viii 1969 (YM), 2♂♂, Kanegasaki, 2 viii 1987 (SKY); *Yamagata-ken* - 1♂, Nukumi-daira, Oguni, 6 ix 1982 (KB); *Miyagi-ken* - 1♂, Rifu, 31 viii 1980 (K. Goukon), 1♀, same loc., 14 ix 1980 (K. Goukon), 1♂, Aoba-yama, 5 ix 1980 (K. Goukon); *Fukushima-ken* - 1♂, Kashima, 28 ix 1973 (YM); *Niigata-ken* - 1♀, "Echigo", 9 vii 1933 (Nohira), 1♀, Shiori-tôge (1000 m alt.), Komaga-take, 1 ix 1979 (HI), 1♂, Senami, 13 viii 1981 (KB), 1♂, same loc., 5 ix 1981 (KB), 1♂, Iwakuzure, 17 ix 1981 (KB), 2♂♂, Gozu-san, Suibara, 20 ix 1981 (HI); *Saitama-ken* - 1♀, Ageo, 31 vii 1980 (T. Sunose), 1♂2♀♀, same loc., 23 vii 1983 (T. Sunose); *Chiba-ken* - 2♂♂, Yokodo, 3 ix 1981 (J. Tsukahara); *Ibaraki-ken* - 1♀, Tsuchiura, 9 viii 1987 (SKY); *Nagano-ken* - 2♂♂, Minamiminowa, Ina, 25 v 1962 (YM), 2♂♂, same loc., 19-21 viii 1961 (YM), 5♂♂, same loc., 25 viii - 2 ix 1961 (YM), 3♂♂, same loc., 5-8 ix 1961 (YM), 4♂♂, same loc., 11-14 ix 1961 (YM), 1♂, 29 ix 1961 (YM); *Gifu-ken* - 1♀, Katachi, Mino, 7 viii 1982 (Y. Takai), 1♀, Hongô, Seki, 11 viii 1982 (Y. Takai), 1♂, Otogari, Mino, 14 ix 1986 (Y. Takai); *Nara-ken* - 1♂, Dorokawa, 29 vii 1955 (O. Sato); *Wakayama-ken* - 1♀, Torokyo, 31 viii 1951 (O. Tsuzimoto).

Sado-ga-shima: 1♂, Mt. Myôken, 12 viii 1979 (N. Kato), 2♂♂, Tagirisu, Mano, 23 ix 1981 (KB).

Shikoku: *Kôchi-ken* - 1♀, Kojigamori, 12 vi 1960 (O. Sato), 1♀, Okoyama, Nankoku, 17 ix 1976 (SI).

Kyûshû: *Fukuoka-ken* - 5♂♂, Kurogi, 28-29 vii 1983 (Y. Takai), 1♀, same loc., 30 viii 1984 (Y. Takai); *Nagasaki-ken* - 1♂1♀, Haraguchi, Ômura, 18-27 viii 1967 (R. Ohgushi); *Kumamoto-ken* - 1♂, Tôyô-mura, 8 viii 1983 (M. Maeda); *Kagoshima-ken* - 5♂♂1♀, Kôrimoto, Kagoshima-shi, 6-7 viii 1981 (SKY), 2♀♀, Meiwa, Kagoshima-shi, 15 viii 1981 (SKY), 3♂♂1♀, Kôrimoto, Kagoshima-shi, 22-26 viii 1981 (SKY), 1♂1♀, Haruyama, 11 ix 1983 (M. Ôhara), 1♂, Eboshi-dake, 25 vii 1984 (AN), 1♂, Iriki, 5 ix 1984 (AN), 1♂1♀, Kaimon-dake, 26 viii 1986 (SKY).

Islands located close to Kagoshima-ken-hondo: *Naga-shima* - 3♂♂, Shoura, 27 viii 1984 (SKY); *Take-shima* (nr Naga-shima) - 2♂♂, 28 viii 1984 (SKY).

N. Ryukyus: *Tane-ga-shima* - 1♂, Ikeno, 21 vii 1984 (S. Watahiki); 1♀, Hamada, 2 viii 1984 (SKY) *Yaku-shima* - 2♂♂, Miyanoura, 8 viii 1981 (SKY), 2♂♂, Onoaida, 9 viii 1981 (SKY), 1♂, Shitogo, 10 viii 1981 (SKY), 2♂♂, Miyanoura, 5 viii 1986 (SKY).

Distribution. Hokkaidô; Honshû; Sado-ga-shima; Awaji-shima; Shikoku; Kyûshû; Tsushima Is.; Gotô Is. (Fukue-jima; Naru-jima); Naga-shima; Take-shima (nr Naga-shima); Ôsumi Is. (Tane-ga-shima; Yaku-shima).

Taxonomic notes. There have been recognized two forms within this species in Japan. Giordani Soika (1941) called one of them "*micado*", in which the punctuation on gastral tergite 2 is quite fine and superficial (Fig. 323) and the yellow body markings are less extensive. In the other, called "*samuray*", the punctuation on tergite 2 coarser (Fig. 322) and the body is more extensively marked with yellow. Giordani Soika treated these two forms as distinct species, and his view has been followed by Sato (1964), Vecht and Fischer (1972)

and Yamane (1977a). Cameron (1904), however, mentioned in his original description of *E. micado* "the dilated part [of the first segment] strongly and closely punctured....; the second segment *closely* and much more finely punctured", and "a large irregular mark, broader than long and with irregular edges, on the sides of the metanotum [=propodeum]". These conditions are those more frequently met in "*samuray*" sensu Giordani Soika. Bequaert (1928) wrote: "The holotype of *E. micado* is a female from Japan, which does not differ from the description of *E. samuray*, nor from two specimens in the British Museum Collection determined as *E. samuray* by A. v. Schulthess. The two specimens, a female (received from A. v. Schulthess as the "type") and a male (labelled "cotype") from Japan, are, I presume, paratypes of *E. samuray*". Tosawa (1934), Iwata (1953) and Ishikawa (1965) correctly recognized only one species (*micado*) (note that Iwata's and Ishikawa's "*samuray*" no doubt correspond to *E. rubronotatus* as discussed earlier).

Suda (1979) studied the variation in structure and coloration with many specimens of "*micado*" and "*samuray*" from the Kantô District, Honshû. He concluded that "*micado*" was represented by spring individuals while "*samuray*" by summer/fall individuals. In mountainous regions both the "*micado*"-type and "*samuray*"-type wasps were collected in summer. After careful considerations on variation, distribution and life cycle, he suspected that "*micado*" and "*samuray*" are spring and summer generations of one and the same species (*micado*). In this paper I have followed his reasoning.

Biology. This common species flies from May to October, and is probably bivoltine. The biology of this species was studied by Iwata (1953, 1978a, 1980c). It nests on the surface of wooden buildings as well as on slender twigs of various kinds of shrubs or trees, but most often on slender rootlets under overhanging cliffs. The mud pot, oval and provided with a large collar, is prepared separately and is not coated with thick mud paste (Fig. 336). Larvae of various moth families are hunted (Iwata, 1978a).

Parasitoid: *Acroricnus ambulator*.

Genus *Delta* Saussure

Delta Saussure, 1855, Et. Fam. Vesp. 3: 130, 132, 143 (as division of genus *Eumenes* Latreille; "*Eumenes*, II^e et III^e Divisions" in Saussure, 1852) (type species: *Vespa maxillosa* DeGeer, 1775 (= *Delta emarginatum* (L.)), designated by Bequaert, 1926); Dalla Torre, 1904, Gen. Ins. 19: 20 (as group of genus *Eumenes*).

Phi Saussure, 1855, Et. Fam. Vesp. 3: 132, 145 (as division of *Eumenes* Latreille; "*Eumenes* IV^e Division" in Saussure, 1852) (type species: *Vespa arenata* Fabricius, 1775, designated by Bequaert, 1926); Dalla Torre, 1904, Gen. Ins. 19: 20 (as group of *Eumenes* Latreille).

Japanese names: Nettarei-suzubachi Zoku (Kurosui-suzubachi Zoku; Haranaga-suzubachi Zoku).

Japanese authors have dealt with the species of *Delta* (including *Phi* of authors) as members of the genus *Eumenes* (e.g., Matsumura, 1911; Tosawa, 1934; Iwata, 1939a). Here, I follow Giordani Soika (1972) who regarded some of Saussure's (1855) divisions as genera. Diagnosis for *Delta* given by Saussure and Dalla Torre (1904) is reproduced below with slight modifications.

Clypeus much higher than wide. Mandible very long, somewhat curved; teeth absent or inconspicuous. Galea 1.5 times as long as the basal part of maxilla; segments of maxillary palp not gradually becoming short (segment 2 >> 1; 3 = 4 + 5 + 6); segment 1

widened in the middle; segment 2 curved and apically widened. Labium with a straight, very long, deeply bifid tongue; paraglossa "fadlich"; segment 2 of labial palp longer than segment 1. Eye large, swollen, narrowly notched. Terminal segments of male antenna very long, recurved to lie on some preceding segments. Thorax [=alitrunk] short. gaster pear-shaped, depressed. Gastral petiole slender, a little longer than the thorax, elongate pear-shaped, posteriorly widened, often in the middle slightly swollen or almost linear, often with a pair of denticles at about middle length, with venter invisible, and slightly impressed. Segment 2 bell-shaped, posteriorly narrowed, widest at 1/3 length from the base or in the middle, never compressed laterally, but slightly depressed dorso-ventrally.

Phi Saussure has been treated by some authors as a distinct genus (e.g., Giordani-Soika, 1972), while Vecht (1981) and Carpenter (1986) synonymized it with *Delta*. Saussure's diagnosis for his IV^c Division (= *Phi*) is as follows: "Labium and maxillae as in II^e Division [now *Delta*]; mandibles very long; [gastral] petiole linear, very long (1.5 times as long as thorax [alitrunk], or more), without obvious denticles; abdomen [gaster] compressed, higher than wide; segment 2 bell-shaped, basally narrowed so as to form a short stalk toward the petiole, and slightly narrower posteriorly than at the middle." According to Giordani Soika (1972) *Phi* is distinguished from *Delta* by the following points: tergite 1 much longer (Fig. 349), subcylindrical and more or less strongly curved; male terminal sternite without longitudinal furrow which is seen in all the members of *Delta* (s. str.). In spite of this fact, in this paper I will tentatively combine these two groups into the genus *Delta*. Furthermore, since the name *Phi* is preoccupied by a subgenus of a New World polistine genus (*Mischocyttarus*), we cannot use this name in Eumenidae (cf. Carpenter & Day, 1988).

Delta has been treated as neuter (Vecht & Fischer, 1972; Gusenleitner, 1987) or as masculine (Giordani Soika, 1972; Vecht, 1981, pers. comm.). Here I follow the most recent work by Giordani Soika (1986) where it is treated as neuter.

This genus is widely distributed in southern Palearctic, Oriental, Australian and Ethiopian regions.

Delta esuriens okinawae Giordani Soika
(Figs. 337-340, 342, 355)

Eumenes campaniformis var. *gracilis* Saussure: Sonan, 1938, Trans. Nat. Hist. Soc. Formosa, 28: 78-79.

Eumenes esuriens Fabricius: Matsumura, 1911, Thous. Ins. Jpn. Suppl. 3: 109, pl. 40, fig. 10; Matsumura and Uchida, 1926, Ins. Matsum. 1: 35; Matsumura, 1930, Ill. Thous. Ins. Jpn. 2: 11, pl. 2, fig. 10; 1931, 6000 Ill. Ins. Jpn.-Emp. p. 15 (no. 74); Tosawa, 1934, Trans. Shikoku Entomol. Soc. 5: 13-14, fig. 9.

Delta campaniforme okinawae Giordani Soika, 1986, Boll. Mus. Civ. Stor. Nat. Venez. 35 (1984): 76-77 (♀ ♂)(type loc.: Ie-jima, Okinawa Is.).

Delta esuriens (Fabricius): Azuma and Kinjo, 1987, Check-list Ins. Okinawa, p. 315.

Japanese name: Kurosuji-suzubachi.

Diagnosis. Female and male. Body length (h+th+t1+2): 17.5-19.0 mm in ♀, 13.5-16.5 mm in ♂. Fore wing length: 14.5-15.0 mm in ♀, 11.0-13.5 mm in ♂. Structurally as in the nominotypical subspecies. Antennal hook (♂) large, received by a concavity of segment 10 (Fig. 339).

Head black, with the following parts yellow (Fig. 337): clypeus, a large interantennal marking, a wide marking on inner orbit which fills up the lower 2/3 of ocular sinus, space

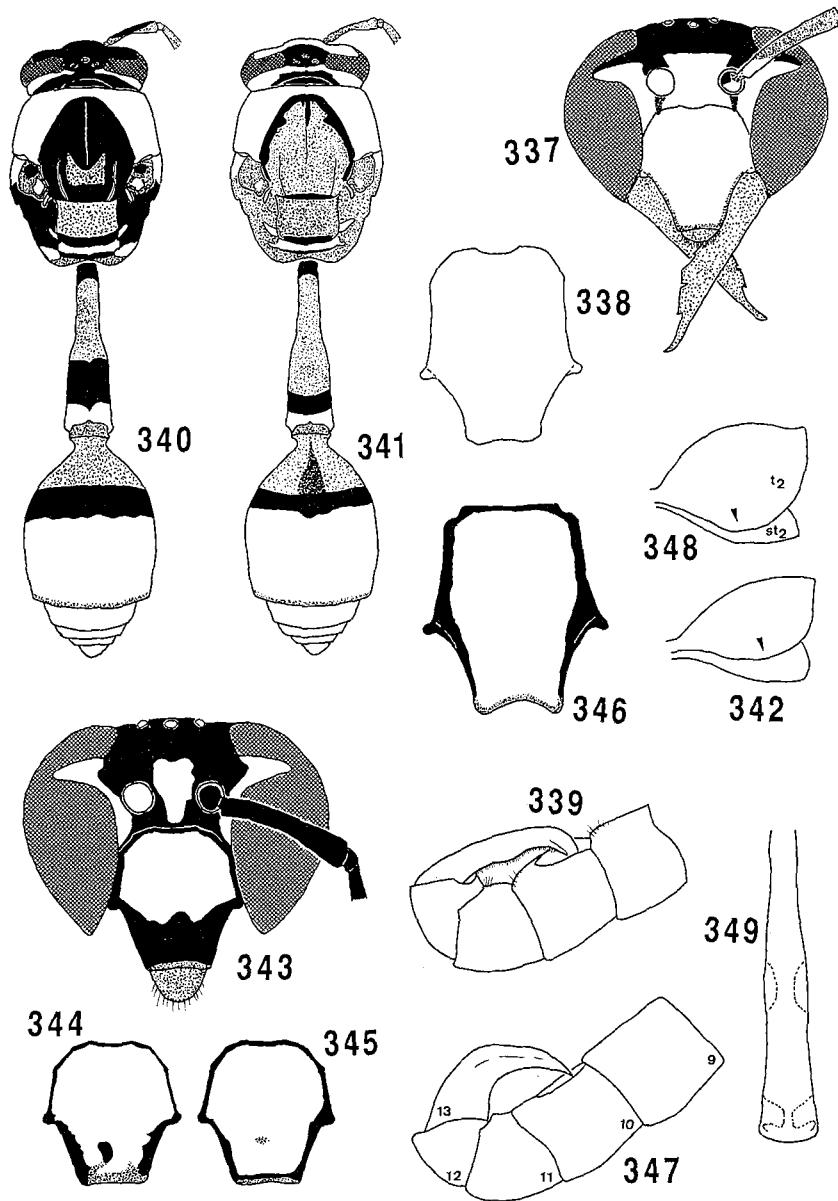

Figs. 337-342. *Delta esuriens okinawae*. 337, head in frontal view (♀); 338, male clypeus; 339, terminal segments of male antenna; 340, body color pattern (ssp. *okinawae*); 341, ditto (ssp. *esuriens*); 342, gastral segment 2 in profile.

Figs. 343-349. *Delta flavopictum formosanum*. 343, head in frontal view (♀); 344, 345, color pattern of female clypeus; 346, male clypeus; 347, terminal segments of male antenna; 348, gastral segment 2 in profile; 349, tergite 1 (petiole) from above.

between clypeus and antennal socket (this yellow part often connected with the interantennal marking), genal band (more developed in ♀). Mandible brownish. Antenna ferruginous, darker in apical segments; scape below yellowish, above blackish or ferruginous. Thorax black, with the following parts yellow: pronotum wholly, a large marking on mesopleuron, apical 1/3 of tegula, parategula, metanotum wholly. Mesoscutum often marked with reddish brown basally; scutellum wholly and upper 2/3 of tegula ferruginous (tegula sometimes with a black spot at base); mesopleuron and metapleuron also sometimes with ferruginous markings. Propodeum brown or ferruginous, posteriorly with a large black basal marking in ♂; posterior face above and below with yellow markings. Legs brown to ferruginous, with yellow markings on fore femur and tibiae of all legs; femora and tibiae extensively blackish and tarsi almost wholly blackish in ♂. Gastral petiole ferruginous; preapical band (incised medially) yellow; a wide band just before the yellow band and basal part of petiole black. Gastral tergite 2 yellow in apical 1/2; basal 2/5 ferruginous; space between the yellow and ferruginous area black, forming a distinct band; ferruginous area often with an inconspicuous black marking at base. Subsequent tergites yellow, but when the segments are extended the basal black parts are visible. Gastral sternites 1 and 2 extensively ferruginous; sternite 2 with a yellow apical band; subsequent sternites yellow with basal part ferruginous.

In the nominotypical subspecies from India (Fig. 341), yellow markings are more abundant especially on head, and alitrunk is extensively ferruginous. One female specimen from Thailand was intermediate between the nominotypical form and *okinawae*.

Materials examined. C. Ryukyus: *Okinoerabu-jima* - 1 ♀, 17 vii 1984 (M. Maegata); *Yoron-tô* - 2 ♂♂, 4 vi 1985 (SKY); *Okinawa-jima* - 1 ♂, Naha, 29 ix 1977 (SY), 2 ♀♀, Kudeken, 30 ix 1977 (SY), 1 ♂, Nakagusuku, 3 x 1977 (SY), 1 ♂, Ogimi-son, 26 viii 1979 (H. Nagase), 1 ♀, Tôbaru, Kunigami, 3 vii 1982 (YH), 2 ♂♂, Hentona, 27 vii 1987 (SKY), 1 ♂, Nago, 3 x 1987 (A. Nagatomi), 2 ♀♀, Ginoza-son, 4 x 1987 (AN); *Kouri-jima* - 2 ♀♀, 18 x 1988 (Y. Kusui); *Yabuchi-jima* - 1 ♂, 22 x 1988 (Y. Kusui); *Hamahiga-jima* - 4 ♂♂ 1 ♀, 22 x 1988 (Y. Kusui); *Tokashiki-jima* - 4 ♂♂ 1 ♀, 11 x 1988 (SKY).

S. Ryukyus: *Miyako-jima* - 5 ♂♂, Gusukube, 17 vii 1987 (SKY), 1 ♂, Hirara, 18 vii 1987 (SKY); *Tarama-jima* - 1 ♂, 19 vii 1987 (SKY); *Ishigaki-jima* - 1 ♀, Ishigaki-shi, 10 x 1977 (SY), 1 ♂, Kabira, 22 vii 1987 (SKY), 2 ♂♂, Shiraho, 26 vii 1987 (SKY); *Taketomi-jima* - 3 ♂♂ 2 ♀♀, 24-25 vii 1987 (SKY); *Kohama-jima* - 1 ♂, 25 vii 1987 (SKY); *Iriomote-jima* - 9 ♂♂ 4 ♀♀, Funaura, 5-9 x 1977 (SY), 1 ♀, Ôtomi, 25 vii 1985 (AN), 1 ♀, Toyohara, 11 x 1987 (AN); *Hateruma-jima* - 1 ♀, 1 vii 1988 (SKY); *Yonaguni-jima* - 1 ♂, Sonai, 5 vii 1988 (SKY).

Distribution. Amami Is. (Okinoerabu-jima; Yoron-tô); Okinawa Is. (Okinawa-jima; Ie-jima; Kouri-jima; Yagaji-jima; Sezoko-jima; Yabuchi-jima; Hamahiga-jima; Tokashiki-jima; Kume-jima); Miyako Is. (Miyako-jima); Tarama Is. (Tarama-jima); Yayeyama Is. (Ishigaki-jima; Taketomi-jima; Kohama-jima; Iriomote-jima; Hateruma-jima; Yonaguni-jima). Taiwan. The nominotypical form ranges from Senegal in the west through Persia to Malay Archipelago in the east (Bequaert, 1918).

Taxonomic notes. The form *esuriens*, originally described from India, is structurally very similar to *D. campaniforme* (Fabricius), and has often been treated as a subspecies of the latter (Gusenleitner, 1987) or of "*Eumenes*" *caffer* (Linné) (Bequaert, 1918). *Esuriens* and *campaniforme* are, however, distinct species (Vecht, pers. comm., 1981): *esuriens* has fine short bristles on inner surface of the terminal segment of male antenna (Fig. 339), while *campaniforme* lacks them. In coloration constant differences exist as follows: in *campaniforme* scutellum and sides of propodeum yellow, and gastral tergite 2 basally with two large yellow spots. I have found no intermediate specimen even in the series containing both the forms from the same or adjacent localities.

Biology. This species builds its pot nests on the depressed part of rock surface. The

pot is hemispherical, and its bottom is widely attached to the substratum. An excellent photo was given by Takara and Azuma (1973; *Eumenes esuriens*). Lepidopterous larvae are hunted for the young. Males wait females around flowers, and the copulation occurs there (Yamamuro, 1988).

Delta flavopictum formosanum (Zimmermann)
(Figs. 343-349, 355)

Eumenes arcuata formosana Zimmermann, 1931, Z. Morph. Oekol. Tiere, 22: 206, fig. 26 (no. 5) (♀ ♂)
(type loc.: Pilan, Taiwan).

Eumenes arcuata Fabricius: Matsumura, 1911, Thous. Ins. Jpn. Suppl. 3: 109-110, pl. 39, fig. 11; Matsumura and Uchida, 1926, Ins. Matsum. 1: 35-36; Matsumura, 1930, Ill. Thous. Ins. Jpn. 2: 12, pl. 2, fig. 11; 1931, 6000 Ill. Ins. Jpn.-Emp. p. 75-76; Tosawa, 1934, Trans. Kansai Entomol. Soc. 5: 15, fig. 4.

Eumenes flavopictus formosanus Zimmermann: Vecht, 1959, Zool. Verh. 41: 39.

Phi arcuata (!) Fabricius: Azuma and Kinjo, 1987, Check-list Ins. Okinawa, p. 315.

Japanese name: Haranaga-suzubachi.

Diagnosis. Body length (h+th+t1+2): 21.5-25.0 mm in ♀, 17.5-20.5 mm in ♂. Fore wing length 18.5-21.0 mm in ♀, 14.5-18.0 mm in ♂. Structure as in the nominotypical form for which a good description was given by Vecht (1959). In profile, gastral tergite 2 more produced below than in *D. esuriens* (Fig. 348 vs. 342). Antennal hook (♂) strongly curved, without hairs on inner face (Fig. 347).

In color pattern the Japanese form is very similar to the Taiwanese one, but ocular sinus is more extensively yellow (Fig. 343), clypeal black marking in the female is generally larger, and fore femur constantly has a yellow line on its outer face. Although color pattern is generally stable in Japan, the black marking on the female clypeus may vary among individuals (Figs. 343-345).

Material examined. S. Ryukyus: *Ishigaki-jima* - 1 ♀, vii 1922 (S. Hirayama), 1 ♀, Banna-dake, 12 vii 1973 (H. Takizawa), 1 ♀, Kabira, 22 vii 1987 (SKY), 7 ♂ ♂ 10 ♀ ♀, Banna-dake, 3-8 vii 1988 (K. Nakamine); *Iriomote-jima* - 2 ♀ ♀, Komi, 24-26 x 1973 (M. Ôwada), 6 ♂ ♂ 2 ♀ ♀, Funaura, 5-9 x 1977 (SY), 1 ♀, Ôhara, 23 v 1981 (AN), 1 ♀, Komi, 17 v 1981 (AN), 1 ♀, Urauchi, 22 x 1981 (T. Moriyama), 2 ♂ ♂, Ôhara, 6 i 1982 (AN), 1 ♀, Komi, 31 vii 1983 (AN), 1 ♀, Ôhara, 29 vii 1983 (AN), 1 ♀, Uehara, 21 xi 1983 (T. Moriyama), 1 ♀, Toyohara, 11 x 1987 (AN), 1 ♂ 2 ♀ ♀, Mihara, 4 xii 1988 (SKY); *Yubu-jima* - 1 ♀, 4 xii 1988 (SKY).

Distribution. Okinawa Is. (Okinawa-jima ?); Miyako Is. (Miyako-jima); Yaeyama Is. (Ishigaki-jima; Iriomote-jima; Yubu-jima). Taiwan. I have not seen any specimen from Okinawa-jima and Miyako-jima.

Biology. The nesting behavior of this form was intensively studied by Iwata (1939a) in Taiwan. Nests are constructed on the flat surface of stone gates or on tree twigs. The nest consists of several quartered-spherical mud pots that are finally covered by mud (secondary coating) into a single cluster. Iwata et al. (1982) present a series of beautiful photos of a nest, though unfortunately the locality is not stated. Sonan (1927) observed a female wasp hunting the larva of a tortricid, *Homona menciana*, in Taiwan, while Iwata (1939a) stated that most of the prey insects stored in brood cells were larvae of Geometridae and Noctuidae.

Genus *Pseumenes* Giordani Soika

Pseumenes Giordani Soika, 1935, Ann. Mus. Civ. Stor. Nat. Genova, 57: 145 (as subgenus of *Pareumenes* Saussure)(type species: *Eumenes eximius* Smith, 1861, original designation).

Japanese name: Kagimon-tokkuribachi Zoku.

Pseumenes and its allied Old World groups had been placed together under *Montezumia* and as divisions or subgenera within the latter until Vecht (1963) raised these to genera and created another genus, *Coeleumenes*. Currently the name *Montezumia* is used only for New World species.

Head elongate in frontal view, higher than wide in ♀. Mandible relatively short (Fig. 350). Thorax depressed, wider than high, oval as seen from above. Mesepisternum without epicnemial carina. Disk of metanotum very slightly convex, well defined laterally. Propodeum gradually sloping from base to apex; the dorsal (posterior) portion sharply demarcated from each lateral portion by a carina which is produced into a distinct process or teeth at the apex of propodeum; dorsal portion basally with a longitudinal slit, from which runs a median carina to the apex. Gastral segment 1 distinctly petiolate (Fig. 353). Gastral sternite 1 with long and narrow anterior part which is weakly striate and fused with the tergite; posterior part short, triangular, not striate (Fig. 354). Outer face of hind tibia not spinose.

Pseumenes depressus depressus (Saussure)

(Figs. 350-355, 361)

Eumenes depressus Saussure, 1855, Et. Fam. Vesp. 3: 135 (♀ ♂)(type loc.: les Indes orientales); Dalla Torre, 1894, Cat. Hym. 9: 22; Tosawa, 1934, Trans. Kansai Entomol. Soc. 5: 6 (*depressa*).

Pareumenes depressa: Dalla Torre, 1904, Gen. Ins. 19: 19; Vecht, 1937, Treubia, 16: 273, fig. 3b (*depressus*: in subgenus *Pseumenes*); Tosawa, 1936, Kansai Konchū Zasshi, 4: 46; Sonan, 1938, Trans. Nat. Hist. Soc. Formosa, 28: 77-78.

Pareumenes quadrispinosus Saussure: Liu, 1941, Notes Entomol. Chin. 8(6): 256 (in key), 280 [misidentification].

Pseumenes depressus depressus: Vecht, 1963, Zool. Verh. 60: 25-26.

Pseumenes depressus (!) (Saussure): Azuma and Kinjo, 1987, Check-list Ins. Okinawa, p. 315.

Japanese name: Kagimon-tokkuribachi.

Diagnosis. Female. Body length (h+th+t1+2): 16.0-19.0 mm. Fore wing length: 16.0-18.0 mm. Head with vertex fairly swollen (Fig. 350); upper portion of frons and anterior portion of vertex densely punctate; the punctures not well defined. Ocellar triangle flat; distance between posterior ocelli much longer than that between posterior and anterior ocellus. Clypeus as wide as high, weakly punctate, apically narrowly emarginate. Labial palp 4-segmented; segment 1 longest and apically widened. Pronotum and mesoscutum except for posterior 1/5 punctate; other parts of thorax impunctate or only very weakly punctate, and somewhat shining. Propodeum laterally weakly striate, and dorsally weakly punctate and shining; propodeal groove with obliquely running striae. Each lateral half of pronotum emarginate at apex (Fig. 353). Gastral segment 1 with parallel sides in anterior half, and gradually widened toward apex, with a preapical longitudinal furrow. Tergite 2 approximately as long as wide, densely but weakly punctate laterally; on

tergites 3-6 punctation quite inconspicuous. Slender anterior part of sternite 1 very weakly striate; punctation on sternites 2-5 very weak; terminal sternite almost impunctate. Parastigma of fore wing more than half as long as stigma.

Black, with the following parts yellow: clypeus wholly (sometimes apically black), a marking along inner side of eye extending onto the whole ocular sinus, a long bar on frons starting at just below anterior ocellus and reaching clypeus, complete genal band, antennal scape below (flagellum below ferruginous), pronotum wholly, a large spot on mesopleuron above, a pair of fishhook-shaped marks on mesoscutum, tegula with a brownish central spot, parategula, a pair of spots on scutellum, a pair of large markings on dorsal face of propodeum each with a median black spot which is often connected to the lateral black area, a pair of small spots on gastral petiole at 2/5 length from apex, a narrow apical band on tergite 1 which is medially and laterally interrupted and extending from each lateral end toward base for some distance, a pair of large basal spots and a wide apical band on tergite 2 (the latter medially incised), apical bands on tergites 3-5 (apical bands 2-5 each containing a brownish, small median spot), an irregular marking or markings on sternite 2, fore femur below, outer face of tibiae of all legs.

Male. Body length (h+th+t1+2): 12.0-14.0 mm. Fore wing length: 11.0-11.5 mm. Very similar to the female in structure and coloration. Body more slender. Head nearly circular.

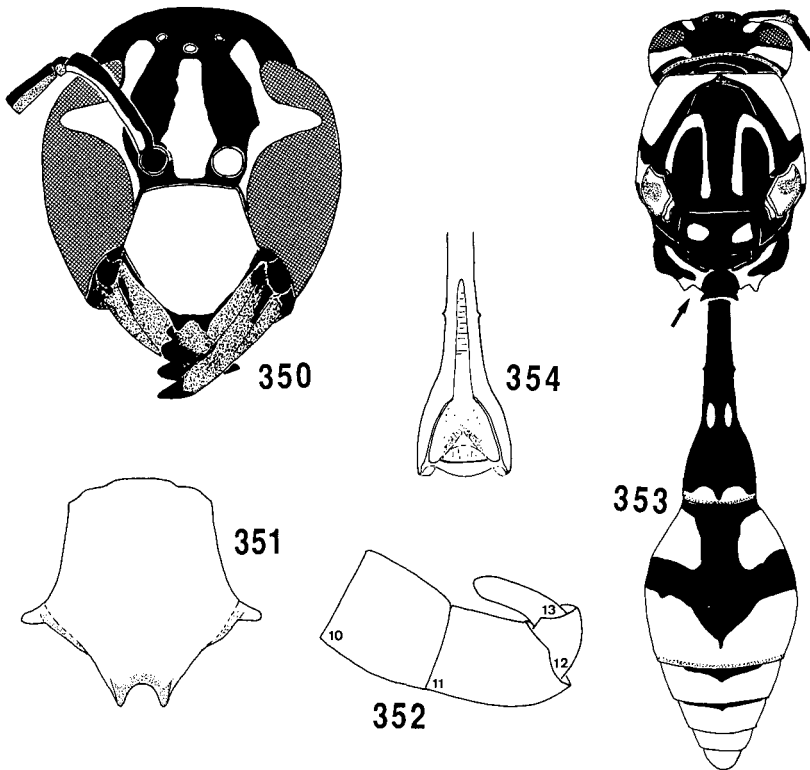

Figs. 350-354. *Pseumenes depressus*. 350, head in frontal view (♀); 351, male clypeus; 352, terminal segments of male antenna; 353, body color pattern; 354, gastral sternite 1.

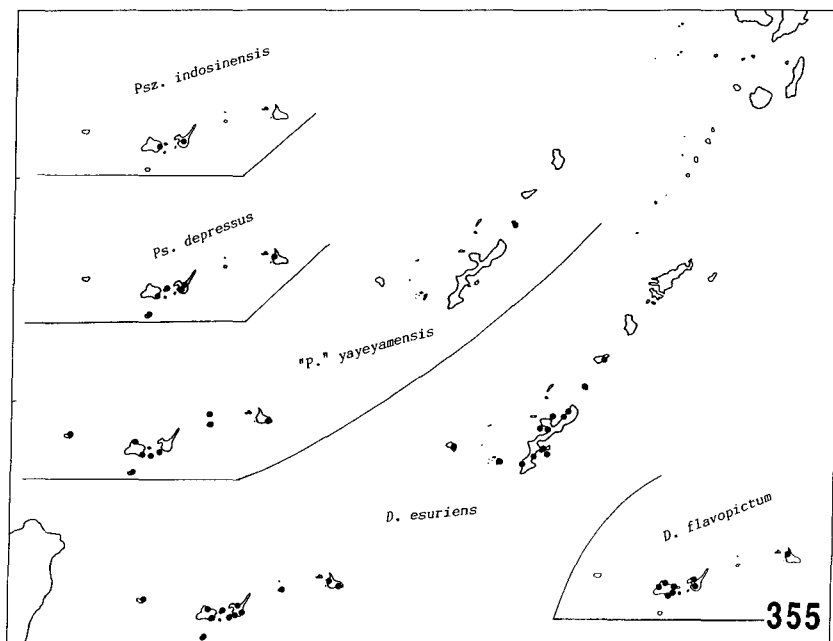

Fig. 355. Distribution of *Pseudozumia indosinensis*, *Pseumenes depressus*, "*Pachymenes*" *yayeyamensis*, *Delta esuriense* and *D. flavopictum* in Japan.

Clypeus higher than wide (Fig. 351). Two apical segments of antenna very small, recurved to reach barely the base of segment 11 (Fig. 352). Mandible with a basal yellow mark. Legs more extensively marked with yellow.

Material examined. S. Ryukyus: *Ishigaki-jima* - 1 ♂, 11 vii 1973 (H. Takizawa), 1 ♂, 16 viii 1983 (S.F. Sakagami & YM), 1 ♂, 22 vii 1987 (SKY), 2 ♂♂, Banna-dake, 4 vii 1988 (SKY), 2 ♂♂, same loc., 8 vii 1988 (K. Nakamine), 1 ♂, Omoto-dake, 8 vii 1988 (K. Nakamine); *Kohama-jima* - 1 ♀, 25 vii 1987 (SKY); *Iriomote-jima* - 1 ♀, Ôhara, 15 v 1981 (AN), 1 ♂, Ôtomi, 29 vii 1983 (AN), 1 ♂1 ♀, Komi, 29-31 vii 1983 (AN); *Hateruma-jima* - 2 ♂♂, 2 vii 1988 (SKY).

Distribution. Miyako Is. (Miyako-jima); Yaeyama Is. (Ishigaki-jima; Kohama-jima; Iriomote-jima; Hateruma-jima). Taiwan; Thailand; Indo-China; Malaya; S. China; India (West Bengal).

Biology. There is little information available about the bionomics of this species in Japan. According to the classical work by Piel (1935, summarized in Liu 1941; in both, referred to as *Pareumenes quadrispinosus*) in southern China, this species nests in long internodes of dry bamboo and makes a small funnel-shaped hole on the side of bamboo near the upper node; provisioning and oviposition are done through this hole. This species is ethologically unique in that hunting caterpillars precedes oviposition (in all the other groups of Eumenidae the order is reversed) and that eggs are directly glued to the inner surface of the cell wall (without a suspensory thread). Iwata (1976, 1980b) reviewed the biology of this species adding his own observations on Hainan Island and in Thailand, but did not confirm Piel's observation regarding the hunting-oviposition sequence.

Yamamuro (1985) observed male behavior in mid-July on Iriomote-jima, the S.

Ryukyus. Males flew between 9:30-15:00 (peak: 11:00-13:00) around flowers of *Vitex rotundifolia* etc., patrolling a certain area including flowers along a regular route. Although female wasps visited flowers in the male-patrolled area, no copulation was observed.

Genus *Pseudozumia* Saussure

Pseudozumia Saussure, 1875, Smiths. Misc. Coll. No. 254(I), p. 128 (division of *Montezumia* Saussure) (type species: *Montezumia indica* Saussure, 1855); Bequaert, 1921, Rev. Zool. Afr. 9: 235-251 (as subgenus of *Montezumia*); Giordani Soika, 1941, Boll. Soc. Venez. Stor. Nat. 2: 33 (as genus); Vecht, 1963, Zool. Verh. 60: 16 (in key), 41-42 (as genus).

Japanese name: Koshibuto-suzubachi Zoku.

This genus is similar to the genus *Pseumenes*, but differs therefrom in the following points: head and thorax rather strongly punctate; mesoscutum with prescutal grooves (fig. 359); mesopleuron with epicnemial carina; gastral segment 1 much shorter (less than twice longer than wide at apex of the tergite); sternite 1 irregularly rugose.

Bequaert's (1921) *Pseudozumia* obviously included species of *Pseumenes*, *Coeleumenes*, *Nortozumia* and *Pseudozumia* (sensu Vecht), and Giordani Soika's (1941) concept included some species of *Coeleumenes*. This genus is mainly Oriental in distribution, being known from Celebes, Java, Sumatra, Borneo, Malaya, Sikkim, southern China, the Philippines, Taiwan, and the Ryukyus.

Pseudozumia indosinensis Giordani Soika (Figs. 355, 356-360, 361)

Pseudozumia indosinensis Giordani Soika, 1960, Boll. Mus. Civ. Venez. 11: 93-94 (♀ ♂)(type loc.: Runji A. Tal, Sikkim).

Montezumia (*Pseudozumia*) *indica* Saussure: Sonan, 1937, Trans. Nat. Hist. Soc. Formosa, 27: 14-15; Sonan, 1938, Arb. Morph. Taxon. Entomol. 5: 69.

Montezumia (!) *indica*: Azuma and Kinjo, 1987, Check-list Ins. Okinawa, p. 315 (Okinawa Is.)

Montezumia (!) *indica*: Matsumura, 1911, Thous. Ins. Jpn. Suppl. 3: 113, pl. 39, fig. 18; 1930, Ill. Thous. Ins. Jpn. 2: 15-16, pl. 2, fig. 18; 1931, 6000 Ill. Ins. Jpn.-Emp. p. 17.

Japanese name: Koshibuto-suzubachi.

Diagnosis. Female. Body length (h+th+t1+2): 16.5-19.0 mm. Fore wing length: 16.0-19.5 mm. Head subcircular (Fig. 356), densely punctate especially on frons and vertex. Clypeus slightly higher than wide, relatively widely truncate at apex, almost flat in apical half; the flat part with a few punctures and irregularly striate; punctation in basal half fine and dense. Supra-antennal area with very minute punctures. Interantennal keel sharp. Depression for cephalic foveae well defined, with a median keel. Occipital carina developed only laterally. Anterior vertical face of pronotum with a few minute punctures; posterior horizontal portion strongly and densely punctate; posterior pronotal lobe with a few punctures. Mesoscutum strongly and densely punctate; the punctation sparser near apex and in posterior portion; spaces between punctures and bottoms of large punctures micropunctate. Prescutal grooves deep, with transverse carinae. Scutellum finely and sparsely punctate; spaces between punctures micropunctate. Furrow between meso-

scutum and scutellum deep in the middle. Tegula sparsely punctate at base; remainder micropunctate. Epicnemium almost impunctate except for lower posterior portion; mesepisternum and mesepimeron strongly and densely punctate and partly reticulate. Punctures on metanotum large, but sparse. Metapleuron with a few punctures. Propodeum without shelf, posteriorly not concave, with a deep median groove; a carina starting from the lower end of the groove; posterior face of propodeum with dense punctures of variable size; each side of the posterior face deeply emarginate at apex (Fig. 359); lateral part with large punctures above and superficially striate below. Gastral segment 1 subpetiolate, shorter than segment 2. Tergite 1 moderately punctate, carinate in the middle; tergite 2 more finely punctate especially in apical 1/3; tergites 3 and 4 with small macropunctures; tergites 5 and 6 micropunctate; tergites 2 and 3 apically with a distinct lamellate area. Sternite 1 irregularly rugose; other sternites more finely punctate than corresponding tergites.

Body almost wholly black. Yellow are: a median marking on clypeus, a transverse frontal mark, antennal scape below, a small basal spot on mandible, a pair of very small spots on the anterior vertical face of pronotum above, apex of each side of dorsal face of propodeum. Antennal flagellum below rufous. Wings blackish.

Male. Body length (h+th+t1+2): 11.0-11.5 mm. Fore wing length: 11.5-12.0 mm. Similar

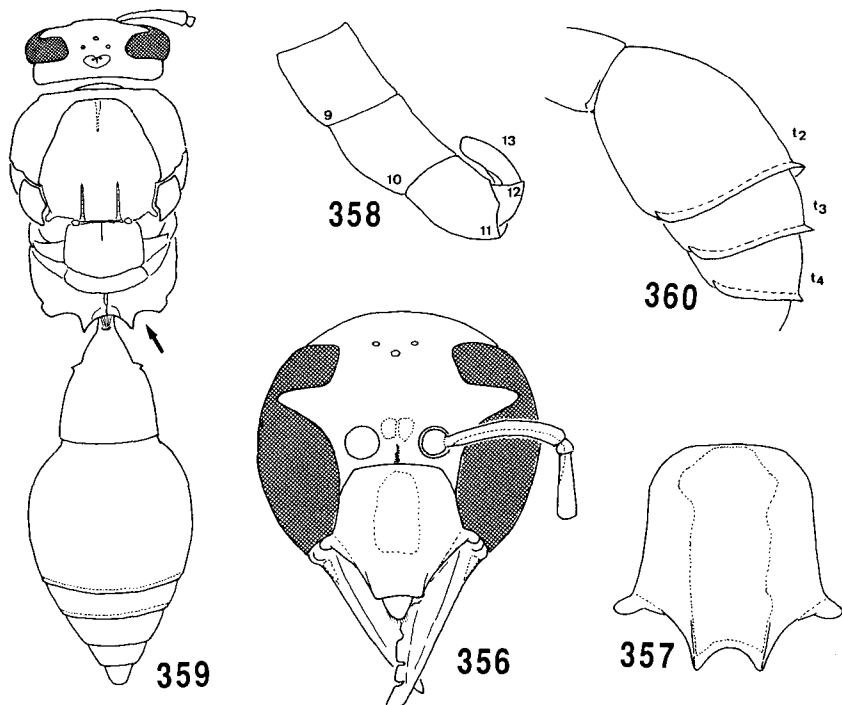

Figs. 356-360. *Pseudozumia indosinensis*. 356, head in frontal view (♀); 357, male clypeus; 358, terminal segments of male antenna; 359, body from above; 360, gastral tergites 2-4 in profile (♂).

to the female in structure and coloration. Clypeus more elongate and distinctly emarginate apically (Fig. 357). Antennal hook not large, just reaching the apex of segment 10 (Fig. 358). In one specimen, propodeum posteriorly with a small medial concavity. Gastral tergites 2-4 with lamellate areas at apex (Fig. 360). Mandible without yellow spot.

Material examined. S. Ryukyus: *Ishigaki-jima* - 2 ♂♂ 3 ♀♀, Banna-dake, 3-8 vii 1988 (K. Nakamine); *Iriomote-jima* - 1 ♀, Komi, 28 vii 1985 (AN).

Distribution. Okinawa Is. (Okinawa-jima after Azuma & Kinjo, 1987) (?); Yaeyama Is. (Ishigaki-jima; Iriomote-jima). Taiwan; continental China; Sikkim. I have not seen any specimen from Okinawa-jima.

Taxonomic notes. This species is readily distinguished from the other congeners by the well-developed apical lamellae on gastral tergites 2 and 3 in the female and 2-4 in the male. According to the original description by Giordani Soika (1960), mid and hind femora are rufous or ferruginous. In the Japanese specimens, however, all femora are wholly blackish.

Biology. Nothing is known of nesting behavior.

VI. DISTRIBUTION PATTERN OF EUMENIDAE IN SOME ISLAND GROUPS IN JAPAN

Japan is an island country, comprising the four main islands Hokkaidô, Honshû, Shikoku, and Kyûshû and some island groups with many islands, most of which are very small. The Japanese mainlands repeatedly became part of the Asian continent during the glacial ages so that their fauna and flora are expected to be essentially very similar to those of the Korean Peninsula, northern China and eastern Siberia. The number of species of a given taxon inhabiting Japanese mainlands should be in general smaller than that inhabiting northeastern part of continental Asia, mainly owing to a much smaller area (cf. MacArthur & Wilson, 1967). In fact Japan lacks such genera as *Pseudepipona* and *Antepipona* that are widely distributed in eastern Asia. However, in some taxonomic groups, we have species endemic to Japan. They may have evolved during interglacial periods when the Japanese mainlands were isolated from the continent by the Japan Sea, and have already completed speciation.

At present, out of the 54 Japanese eumenid species ten are known only from the Japanese Archipelago (mainlands and nearby islands), six are endemic to the Ryukyus or Ogasawara Islands, and one is endemic to the Tsushima Islands. The others are found also in Korea, Taiwan, continental China, eastern Siberia or Europe, though the Japanese populations are often differentiated at subspecies level. Most (7 spp.) of the species known only from the Japanese Archipelago belong to the genus *Symmorphus*, which is one of the most poorly studied genera in the Far East. It is possible that some of the Japanese species also occur on the continent. Furthermore, another species (*Euodynerus bicingulatus* Giordani Soika) is a doubtful taxon as discussed before. The remaining two (*Stenodynerus tokyanus* and *Ancistrocerus japonicus*) are apparently peculiar to Japan, but should be subjected to further faunistic surveys on the continent.

The area-species relation for the mainlands, Sado-ga-shima, Awaji-shima and Yakushima is shown in Table 3. The largest species number (36) is found on Honshû, which has the largest area and covers the longest distance from north to south. On the second largest island Hokkaidô, however, only 22 species are known to occur. This may be partly due to the insufficient survey, but mainly caused by the fact that most of the warm-temperate

Table 3. Number of eumenid species on the Japanese mainlands and some relatively large islands.*

Genera	Hokkaidô (78073)	Honshû (227414)	Sado I. (857)	Awaji I. (593)	Shikoku (18256)	Kyûshû (36554)	Yaku I. (501)
<i>Discoelius</i>	1	1			1	1	1
<i>Stenodynerus</i>	3	4	1		3	4	3
<i>Allodynerus</i>	1	2					
<i>Euodynerus</i>	2	4		1	2	3	2
<i>Rhynchium</i>		1		1	1	1	
<i>Anterhynchium</i>	1	2	1	1	2	2	1
<i>Pararrhynchium</i>		1		1	1	1	
<i>Orancistrocerus</i>		1	1	1	1	1	1
<i>Ancistrocerus</i>	6	6	1		2	2	1
<i>Symmorphus</i>	5	9	3		5	3	
<i>Oreumenes</i>	1	1	1		1	1	1
<i>Eumenes</i>	2	4	2	1	4	4	2
Total	22	36	10	6	23	23	12

* Island areas are given in parentheses in km².

species do not extend northward beyond the Tsugaru Strait. The species number (23) for Shikoku is the same as that for Kyûshû that is approximately twice as large as Shikoku in area. The main reason for this might be ascribed to relative collection efforts on these two islands. Mountainous regions of Shikoku were intensively surveyed by Mr. Y. Sugihara in the early 1900s, whereas no such effort has been made on Kyûshû. Furthermore, there is no subtropical eumenids that have their northern limits of distribution in Kyûshû; in other hymenopteran groups subtropical forms often have their northern limits in southern Kyûshû and contribute to enriching the fauna of Kyûshû (e.g., *Odontomachus monticola* in Formicidae and *Scolia kuroiwae* in Scoliidae).

In short, the eumenid fauna of Japan is characterized by many Palearctic (especially eastern Palearctic) elements, some Oriental species and some endemic ones in the Ogasawara or Ryûkyû Islands. Eventually only a few will prove to be endemic to the Japanese Archipelago. The genus *Ancistrocerus* is notable in that most species found in Japan have quite wide distribution ranges and have not undergone subspeciation in Japan. *A. antilope* is the only species with a Holarctic distribution among the Japanese Eumenidae.

In the following lines I will discuss the distribution pattern of eumenids in some island groups that have been relatively well studied.

1. Sado-ga-shima (Niigata-ken)

The eumenid fauna of this relatively large island quite resembles that of the opposite part of the mainland of Honshû (Niigata-ken-hondo), but much poorer than the latter in species number. Only eight species (*Stenodynerus* sp., *Anterhynchium flavomarginatum*, *Orancistrocerus drewseni*, *Symmorphus foveolatus*, *S. decens*, *S. apiciornatus*, *Oreumenes decoratus* and *Eumenes micado*) had been known by 1982 (Baba, 1935; Yasumatsu, 1935d; Yamane, 1982b; Ônuma, 1989a), and the present study has added two (*Ancistrocerus japonicus* and *Eumenes rubronotatus*). Thus, only ten (43.5 %) of the 23 species inhabiting

the whole Niigata-ken are known from Sado-ga-shima. The percentage is even small in comparison with social wasps (Vespidae) (13 out of 22 spp., 59.1 %) (note that Sado-ga-shima is the only non-mainland island in Japan where *Vespa crabro* occurs). Though further collection efforts will add some species, the known faunal composition and its characteristics in comparison with Niigata-ken-hondo can be explained by the geological history of the island and the current biogeographical theory. This island may have become close to (but not connected with) the mainland during the last glaciation (Würm).

Imadaté and Kaneda (1984) stated that out of the 17 Protura species found in the whole Niigata-ken, 13 (76.5 %) inhabit also Sado-ga-shima. Although the island has neither endemic species nor subspecies, the Protura fauna is rather rich in species number. Further, in different localities, different sets of Protura species tend to occur. This means that Sado-ga-shima is large enough to harbor these small insects, by partitioning the island into numerous habitats. Higuma (1987) gave other examples. Forty eight (48.5 %) out of the 99 Odonata species inhabiting Niigata-ken-hondo have been recorded from Sado-ga-shima. For resident butterflies a similar figure (71 out of 125: 56.8 %) is given. The cicada fauna of this island is much richer: 10 (83.3 %) out of the 12 species inhabiting Niigata-ken-hondo have been recorded. In these three groups there are virtually no species that occur on Sado-ga-shima but not on Niigata-ken-hondo. Thus, the insect fauna of Sado-ga-shima is essentially the same as that of Niigata-ken-hondo, but more or less poorer than the latter.

2. Izu Islands (Tôkyô-to)

This island group consists of some ten small islands lying just south of the Kantô

Table 4. Vespid wasps recorded from the Izu Islands.

Island	Area (km ²)	Distance from Honshû	Species recorded	References
Izu-ôshima	90.99	22 km	<i>Polistes hebracus</i> ¹⁾ <i>P. h. nigruotum</i> ²⁾	Kamiya, 1931
To-shima	4.19	29	<i>Polistes jadwigae</i> ³⁾ <i>Rhynchium japonicum</i> ⁴⁾	Kamiya, 1934
Nii-jima	23.42	35	Seguro-ashinagabachi ⁵⁾ <i>Polistes yokohamae</i> ⁶⁾ <i>Vespa tropica pulchra</i>	Umeya, 1956a
Shikine-jima	3.82	40	No species recorded	
Kôzu-jima	18.58	47	Seguro-ashinagabachi ⁵⁾ Ki-ashinagabachi ⁶⁾	Umeya, 1956b
Miyake-jima	55.14	75	No species recorded	
Mikura-jima	19.69	100	No species recorded	
Hachijô-jima	69.17	178	<i>Stenodynerus tokyanus</i> <i>S. frauenfeldi</i>	Yamane & Gusenleitner, 1982
Hachijô-kojima	3.22	178	<i>Odynerus frauenfeldi</i> ⁷⁾	Sawada & Watanabe, 1959
Aoga-shima	5.23	246	<i>Stenodynerus frauenfeldi</i>	Present study

1) =? *Polistes rothneyi*; 2) =? *P. jadwigae*; 3) = *P. jadwigae*; 4) = *Anterhynchium flavomarginatum*;
5) = *Polistes jadwigae*; 6) = *P. rothneyi*; 7) = *Stenodynerus frauenfeldi*.

District (Honshû) between 30°24'N and 34°45'N. Regarding the Vespoidea, up to now only three eumenid, two polistine and one vespine species have been recorded from these islands (Table 4). No relict or endemic species has been known in these groups. The population of *Stenodynerus tokyanus* is differentiated into a distinct geographical race endemic to Hachijô-jima. It is not clear whether all of the other species recorded are native or not, because hibernating queens (social wasps) and prepupae (eumenids) can be transported via human activities over a long distance. However, the fact that the queen of *Vespa tropica* generally overwinters in soil or decaying stumps (Matsuura, 1966) strongly suggests that there has been few chances for this species to be introduced by man. If so, the sole food of its young, the polistines, must have been also native. On the other hand, it is often thought that two eumenid species, *Anterhynchium flavomarginatum* and *Stenodynerus frauenfeldi*, are apt to be transported with bamboo or reed tubes in which they nest. Data pertaining to this possibility are, however, at present not available.

Kurosawa (1978) mentioned that the insect fauna of the Izu Islands is quite poor and principally the same as that of Japan proper in species composition, with a few endemic species such as *Lucanus gamunus* (Coleoptera, Lucanidae). This is also true of the vespid fauna; only approximately 10 % (with no endemic) of the species known from lowland Honshû occur on the islands (present study). Kurosawa ascribed such features to the relative closeness of this archipelago to the Honshû mainland and the occurrence of a peninsula called Paleo-Izu Peninsula during the Pleistocene. Ikeda (1984), on geological basis, criticized the latter aspect of Kurosawa's argument, stating that the Paleo-Izu Peninsula if any occurred 3 million years ago, and that during the Quaternary many islands in this region repeatedly appeared from and sank into the sea by volcanic activities. Sunose (1981) also doubted the Pleistocene connections of the Izu group with Honshû mainly based upon the distribution pattern of a gall-midge, *Masakimyia pustulae*. Aside from the controversy, considering the sizes of the extant islands they must possess the nature of oceanic islands. In this respect, the fact that the only eumenids inhabiting there are species of *Anterhynchium* and *Stenodynerus* is of special interest, because they are often principal components of eumenid faunas on small islands in temperate Japan.

3. Tsushima Islands (Nagasaki-ken)

Two main islands of Tsushima (Kami-agata and Shimo-agata) have been relatively intensively surveyed for vespid fauna. The most interesting aspect in biogeography of this island group is the mixed occurrence of Korean (continental) and Japanese elements. Also interesting is the occurrence of endemic species and subspecies.

In the present study has been recognized a total of 13 eumenid species from this island group (*Stenodynerus frauenfeldi*, *S. chinensis*, *S. clypeopictus*, *Euodynerus nipanicus*, *Anterhynchium flavomarginatum*, *A. melanopterum*, *Pararrhynchium ornatum*, *Orancistrocerus drewseni*, *Symmorphus tsushmanus*, *Eumenes punctatus*, *E. micado* and *Oreumenes decoratus*). This figure corresponds to ca. 62 % of the total number of species inhabiting the Kyûshû mainland. Of these only one species (*Symmorphus tsushmanus*) is at present considered to be peculiar to Tsushima, all the others inhabiting also continental Asia, while the Japanese mainlands lack one of them, *Eumenes punctatus*.

Among the Vespoidea, *Vespa tropica esakii* Sonan and *Anterhynchium flavomarginatum tsushimarum* are no doubt endemic to Tsushima (Ishikawa, 1970). *V. t. esakii* is very peculiar in having the last gastral tergite almost completely yellow. In almost all the other subspecies of this species, the last two tergites are extensively black (a condition also seen

in *V. affinis*). Over the greater part of its distribution range, *V. tropica* seems to mimic *V. affinis* that is widely sympatric with the former (Yamane, unpubl.). On the Japanese mainlands *V. tropica* has not undergone a drastic transformation in color pattern despite of the fact that *V. affinis* is lacking there (Matsuura & Yamane, 1984), while on Tsushima it has lost the black maculation on the last tergite. This condition may be explained by supposing a simple genetic drift in the small population, but actually it can be mimicking *V. mandarinia japonica* and *V. analis insularis*, both also occurring on Tsushima. On the other hand, *Anterhynchium flavomarginatum tsushimarum* is quite unique in possessing an almost wholly black body, while there is known no candidate model of this wasp. Ishikawa (1970) mentioned that the subspecies *micado* occurs in Korea as well as on the Japanese mainlands, but actually the Korean population belongs to another subspecies, *A. f. koreanum* (Yamane, 1981), which is much more melanic than *micado*. In this respect *tsushimarum* seems to have originated from more probably a *koreanum*-type than *micado*-type population (or individual).

Shirôzu (1980) pointed out that the insect fauna of Tsushima is a mixture of subtropical and boreal elements in addition to the basic species composition common to warm-temperate Japan. This is not true of the vespoid fauna at least. No subtropical species such as *Delta* spp., "*Pachymenes*" *yayeyamensis* and *Okinawepipona kogimai* occur, and the north-temperate and boreal genus *Ancistrocerus* is completely lacking.

4. Ogasawara Islands (Tôkyô-to)

Up to now the following five eumenid species have been recorded from this archipelago: *Stenodynerus ogasawaraensis*, *S. frauenfeldi*, *Euodynerus nipanicus*, *Anterhynchium flavomarginatum* and *Pararrhynchium oceanicum*. Most records came from the two main islands, Chichi-jima and Haha-jima; other islands have been very insufficiently surveyed. Of the five species two (40 %; *S. ogasawaraensis* and *P. oceanicum*) are endemic to the archipelago, and are each differentiated into two geographical races there. The two species are no doubt involved in Müllerian mimicry. The Ogasawara populations of the other three species are very similar to those of Honshû in color pattern, though the specimens of *A. flavomarginatum* from Chichi-jima and Haha-jima are, in some respects, of subspecies *procella*-type (*procella* inhabits the Mi-shima Is., the N. Ryukyus).

The two endemic species are very peculiar in structure and color pattern, apparently having no close relatives in Japan proper and the South Pacific. They possess some tendencies in common: mesosoma is extensively marked with yellow, gastral tergites 1 and 2 are wholly rufous except for apical yellow bands, and the punctuation on mesosoma and gaster is very weak. These conditions are quite exceptional in the genera *Stenodynerus* and *Pararrhynchium*. The derivation of these species is at present unknown (but see under *S. ogasawaraensis*).

The percentage endemism for the whole insects occurring in the Ogasawara group is rather high: 185 (29.8 %) out of the 620 recorded species are endemic (Habu, 1986). Endemism is especially outstanding in Diptera, Hymenoptera, Coleoptera, Hemiptera and Odonata. Among bees, 9 out of the ten recorded species are peculiar to this island group (Nakane, 1970; Ikudome, 1989). The remaining one, *Apis mellifera*, was no doubt introduced by man for apiculture. The three eumenids that are not endemic might have been introduced through human activities. Unlike the honeybee, these wasps are generally not considered to be beneficial insects in Japan so that it is not likely that they have been introduced intentionally. But their immatures are apt to be transported by ship

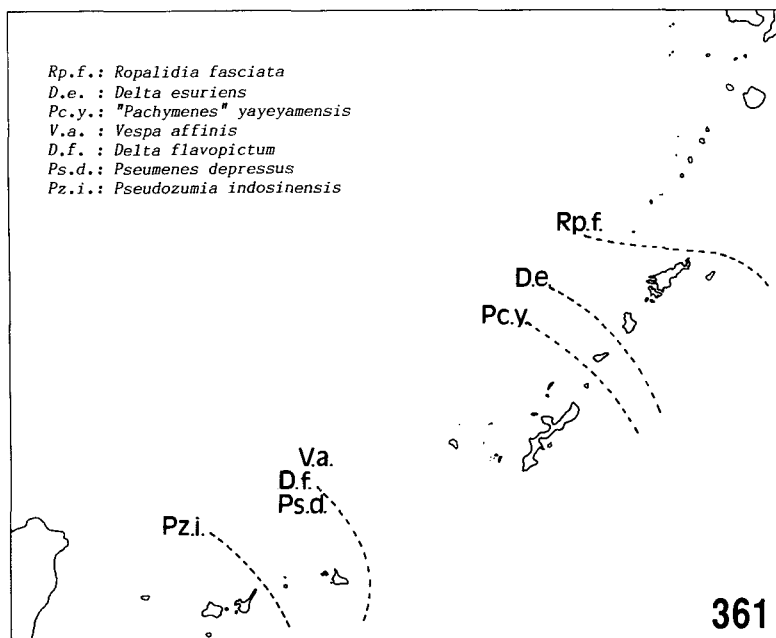

Fig. 361. Northern limits of distributions of some Oriental species of Vespoidea.

together with reed and bamboo tubes in which their nests are constructed. A similar reasoning may apply to *Polistes jadwigae* (referred to as *P. fadwigae* in Nakane, 1970), whose overwintering new queens are easily transported by ship together with loaded goods.

Kurosawa (1976) mentions that approximately 30 % of the beetles recorded from Ogasawara are endemic and that more than 30 % may have been accidentally introduced by man. Among indigenous species, those living in the dead wood are dominant. He argued that these beetles might have migrated on driftwood from various sources. Among Aculeata, *Xylocopa* (*Koptortosoma*) *ogasawarenensis* is a candidate with this dispersing mechanism.

5. Ryūkyū Islands (Kagoshima-ken and Okinawa-ken)

5.1. *Relative abundance of Palearctic and Oriental species.* Twenty five species are known from this archipelago situated in the warm-temperate and subtropical zones (Table 5). On the biogeographical basis, they are sorted into four categories as follows:

A. *Palearctic species.* Species that are found on the Japanese mainlands but not in Taiwan and other parts of Southeast Asia. They, therefore, have the southern limits of their ranges somewhere in the Ryūkyū Archipelago in at least Japan. The following eight species are included in this category: *Discoelius japonicus*, *Stenodynerus frauenfeldi*, *S. chinensis*, *S. tokyanus*, *Euodynerus nipanicus*, *Ancistrocerus japonicus*, *Eumenes rubronotatus* and *E. micado*. Of these, *Euod. nipanicus* has a close relative in Taiwan (Yamane & Gusenleitner, unpubl.), and might eventually prove to be conspecific with the latter.

B. *Wide-ranging species.* The species of this category generally occur almost throughout the archipelago, and also in both Japan proper and Taiwan. This category

corresponds to Ikehara's (1966) "whole-area-type" applied to the termites of the Ryukyus. Seven species are included: *Euodynerus dantici*, *Euod. trilobus*, *Rhynchium quinquecinctum*, *Anterhynchium flavomarginatum*, *Orancistrocerus drewseni*, *Pararrhynchium ornatum* and *Oreumenes decoratus*. Judging from the color pattern, the Ryūkyū populations of some species (*O. drewseni*, *P. ornatum* and *Oe. decoratus*) are considered to have been derived from the forms of Japan proper. Solely females have been collected for *O. drewseni* and this fact supports the above suggestions, since the Taiwanese form of this species adopts sexual reproduction. On the other hand, the populations of *Euod. dantici* in the Central and Southern Ryukyus are not distinguishable from the form of Taiwan in color pattern. However, all these species are tentatively included in this category.

C. Endemic species. This category includes species that are found only within the Ryūkyū Archipelago. The following four species are known: *Stenodynerus rufomaculatus*, *S. kusigematii*, *Pararrhynchium tsunekii* and *P. ishigakiense*. The two species of *Pararrhynchium* are closely related to *P. ornatum* and may have originated from the latter. However, the situation is somewhat complicated, because *P. ornatum* is found in both Japan proper and Taiwan. At present the dispersal route or routes of the supposed ancestors of *P. tsunekii* and *P. ishigakiense* into the Ryukyus cannot be determined. On the other hand, the two *Stenodynerus* species (*rufomaculatus* and *kusigematii*) have the closest relatives (*frauenfeldi* and *tokyanus*, respectively) in Japan proper, but no relatives in Taiwan.

D. Oriental species. This category, corresponding to Ikehara's (1966) "south-area-type", includes species that occur in Taiwan or widely in Southeast Asia and have the northern limits of their distribution in the Ryukyus (Fig. 361). The following six species may belong to this category: *Okinawepipona kogimai*, "*Pachymenes*" *yayeyamensis*, *Delta esuriens*, *D. flavopictum*, *Pseumenes depressus* and *Pseudozumia indosinensis*. *O. kogimai* and "*P.*" *yayeyamensis* are at present known only from the Ryukyus and Taiwan; the others have much wider ranges in Southeast Asia.

The relative abundance (no. species in percentage) of these four categories in the Ryukyus is shown in Fig. 362. In the S. Ryukyus, the proportion of Oriental species is

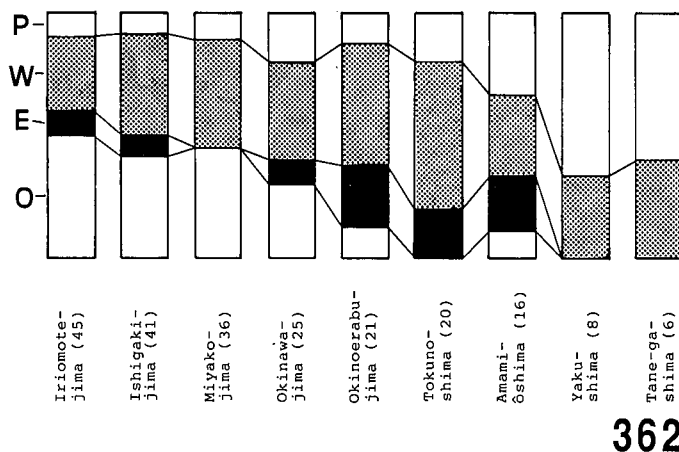

Fig. 362. Proportions of species of the four categories on some large islands in the Ryukyus. P, Palaearctic species; W, wide-ranging species; E, endemic species; O, Oriental species (see text). Island codes are in parentheses.

Table 5. Distribution of eumenids in the Ryūkyū and Daitō Islands

Code*	DJ	SF	SR	SC	ST	SK	ED	EN	ET	RQ	AF	OK	PO	PT	PI	OaD	AcJ	PcY	OeD	EuR	EuM	DIE	DIF	PsD	Pzl**	Code	
1		+														+										1	
2																											2
3					+				+		+										+						3
4					+						+																4
5					+						+																5
6	+	+		+				+			+		+			+			+	+	+						6
7		+						+			+																7
8	+	+		+	+			+	+		+					+	+		+	+	+						8
9		+		+				+	+		+								+	+							9
10											+																10
11											+	+															11
12											+	+															12
13											+	+															13
14										+	+	+	+														14
15			+					+		+	+																15
16	+	+				+		+	+	+	+	+	+		+												16
17			+					+	+	+	+																17
18							+	+		+	+																18
19											+	+															19
20						+	+	+		+	+																20
21		+				+	+	+	+	+	+												+				21
22		+					+	+	+	+	+							+					+				22
24								+	+	+																	24
25		+				+	+	+	+	+	+	+	+					+				+	?		?		25
26							+		+	+																	26
27							+	+	+	+																	27
28								+	+	+	+	+															28
29																											29
30											+	+															30
31							+	+																			31
32								+		+																	32
35			+				+	+	+	+	+												+				35
36							+	+	+	+	+							+					+	+	+		36
39								+		+														+			39
40										+																	40
41							+	+	+	+	+				+				+	+			+	+	+	+	41
42							+			+	+							+					+				42
43										+	+																43
44								+		+													+		+		44
45								+	+	+	+				+								+	+	+	+	45
46										+	+																46
48							+	+		+	+												+		+		48
49						+		+	+	+	+				+								+				49
51										+																	51
52										+																	52
Total	3	6	6	6	1	5	14	25	17	27	33	4	1	1	3	2	1	13	4	5	2	17	3	5	2		

*Island codes as in Fig. 4 and Table 7.

**DJ, *Discoelius japonicus*; SF, *Stenodynerus frauenfeldi*; SR, *S. rufomaculatus*; SC, *S. chinensis*; ST, *S. tokyanus*; SK, *S. kusigematii*; ED, *Euodynerus dantici*; EN, *E. nipanicus*; ET, *E. trilobus*; RQ, *Rhynchium quinquecinctum*; AF, *Anterhynchium flavomarginatum*; OK, *Okinawepipona kogimai*; PO, *Pararrhynchium ornatum*; PT, *P. tsunekii*; PI, *P. ishigakiense*; OaD, *Orancistrocerus drewseni*; AcJ, *Ancistrocerus japonicus*; PcY, "*Pachymenes yayeyamensis*"; OeD, *Oreumenes decoratus*; EuR, *Eumenes rubronotatus*; EuM, *E. micado*; DIE, *Delta esuriens*; DIF, *D. flavopictum*; PsD, *Pseumenes depressus*; Pzl, *Pseudozumia indosinensis*.

Table 6. Subspecies differentiation in the three subregions of the Ryūkyū Archipelago.

	Eumenidae		Vespinae*		Total	
	A	B	A	B	A	B**
N. Ryukyus	1	3	3	0	4	3
C. Ryukyus	5	9	3	2	8	11
S. Ryukyus	4	4	2	2	6	6

* After Yamane (1987, 1988).

** A: Number of species that have subspecies confined to the Ryūkyūs.

B: Number of their Ryūkyū subspecies altogether found in each subregion.

highest, while that of Palearctic species is lowest. The Central Ryukyus are characterized by the high proportion of wide-ranging species and the relatively high proportion of endemic species. This agrees with the general expectation that the islands that are very remote from the source areas mostly consists of specialized species (or relicts) and species with a great ability to disperse. In the N. Ryukyus the Palearctic elements are dominant and no Oriental and endemic species found.

The largest gap in species composition is found between Amami-ōshima and Yakushima, where the border of the Oriental and Palearctic regions is said to exist. This border, originally recognized for land vertebrates and called Watase's line, is often not significant for winged insects (Ikehara, 1966). However, there is generally a profound gap in species composition somewhere between these two islands even in insects (e. g., Terayama, 1982), though the precise position of Watase's line is controversial and may depend on animal groups. More important is whether this gap has been caused by geological history (early establishment of the Tokara Strait) or by climatic factors. This question may be answered only after the distribution of species (or groups) concerned is carefully studied in continental China.

5.2. *Subspecies differentiation.* Five of the 25 species are more or less differentiated into subspecies (geographical races) in the Ryūkyū Archipelago. The number of subspecies per species ranges from two to seven in the following order: *Rhynchium quinquecinctum* and *Okinawepipona kogimai* (2) - *Euodynerus nipanicus* (3) - *Stenodynerus kusigematii* (4) - *Anterhynchium flavomarginatum* (7). No Oriental species has subspecies peculiar to the archipelago, while the wide-ranging and endemic types have an equal number (2) of species that are differentiated into subspecies in the archipelago. The number of such species and the total number of their subspecies endemic to the Ryukyus are both largest in the C. Ryukyus (Table 6). This means again a longer history of isolation of the populations in the C. Ryukyus mainly through distance effect.

The geographical borders of subspecies often lie between the three major subregions (for example, in *Euod. nipanicus* and *R. quinquecinctum*). In other cases, however, distinct subspecies occur on one or a few islands, some of which are very small (*A. flavomarginatum* and *S. kusigematii*). According to Kimoto (1979) some chrysomelid beetles in the Ryukyus also have distinct color forms on small islands such as Naka-no-shima, Okino-erabu-jima, Miyako-jima and Yonaguni-jima. He argues that these differentiations occurred rapidly by genetic drift in small populations after the defaunation during the Ryūkyū period, when many low islands were submerged, followed by recolonization.

5.3. *Area-species relation.* The relationships between island areas and species numbers for the Ryūkyū eumenids and vespoids as a whole are shown in Table 7 and Figs. 363-366.

Table 7. Species numbers of vespoid groups in the Ryūkyū and Daitō Islands.

Code	Islands	Area (km ²)	Highest point(m)	Eumenidae		Vespidae		Total	Code
						Polistinae	Vespinae		
1	Ie-jima	0.61	95.0	2	1	-	3	1	
2	Mukai-jima	1.75	324.6	1	1	-	2	2	
3	Kuro-shima	15.69	621.9	4	3	-	7	3	
4	Iō-jima	11.71	703.7	2	1	-	3	4	
5	Take-shima	4.18	219.9	2	1	-	3	5	
6	Tane-ga-shima	447.42	282.3	10	5	4	19	6	
7	Mage-shima	8.40	71.1	4	-	-	4	7	
8	Yaku-shima	500.59	1935.3	12	6	6	24	8	
9	Kuchinoerabu-jima	38.04	657.0	7	3	2	12	9	
10	Kuchi-no-shima	13.25	628.3	1	2	-	3	10	
11	Naka-no-shima	27.50	979.0	2	3	2	7	11	
12	Suwanose-jima	22.32	799.0	1	-	-	1	12	
13	Akuseki-jima	7.03	584.0	1	1	-	2	13	
14	Takara-jima	5.94	291.9	4	1	-	5	14	
15	Kikai-jima	55.71	224.0	3	3	-	6	15	
16	Amami-ōshima	718.74	694.4	9	5	3	17	16	
17	Kakeroma-jima	75.15	329.0	4	2	2	8	17	
18	Uke-shima	13.70	398.4	3	3	-	6	18	
19	Yoro-shima	9.48	297.0	2	2	1	5	19	
20	Tokuno-shima	248.11	644.8	5	3	2	10	20	
21	Okinoerabu-jima	94.54	246.0	7	3	-	10	21	
22	Yoron-tō	20.82	97.1	6	2	-	8	22	
24	Izena-jima	13.87	119.9	3	2	-	7	24	
25	Okinawa-jima	1182.52	498.0	10	5	1	16	25	
26	Kouri-jima	2.99	107.4	2	3	-	5	26	
27	Yagaji-jima	7.79	55.2	5	3	-	8	27	
28	Sezoko-jima	3.43	40.8	5	2	-	7	28	
29	Yabuchi-jima	0.62	42.4	1	1	-	2	29	
30	Hamahiga-jima	2.01	78.7	3	4	-	7	30	
31	Miyagi-jima	5.57	121.4	2	2	-	4	31	
32	Tokashiki-jima	15.75	227.3	3	2	-	5	32	
35	Kume-jima	58.50	326.0	7	4	-	11	35	
36	Miyako-jima	159.00	114.6	9	3	1	13	36	
39	Tarama-jima	19.88	34.4	4	2	1	7	39	
40	Minna-jima	2.51	8.0	2	2	1	5	40	
41	Ishigaki-jima	223.41	525.8	11	5	3	19	41	
42	Taketomi-jima	5.53	20.5	5	2	1	8	42	
43	Kuro-shima	10.04	14.0	3	2	1	6	43	
44	Kohama-jima	8.26	99.4	5	2	1	8	44	
45	Iriomote-jima	287.66	469.7	10	4	3	17	45	
46	Hatoma-jima	1.00	33.8	3	2	-	5	46	
48	Hateruma-jima	12.68	59.5	7	2	1	10	48	
49	Yonaguni-jima	28.38	231.2	8	3	1	12	49	
51	Kitadaitō-jima	12.58	74.6	1	-	-	1	51	
52	Minamidaitō-jima	30.59	75.8	1	-	-	1	52	

*Island codes correspond to those in Fig. 4.

**Eumenids are recorded also from Irabu-jima and Yubu-jima, but they are omitted because the faunal survey is not sufficient.

Probably owing to insufficient surveys and reflecting variation in topography and remoteness among the islands plotted, the points are widely scattered around the regression line, but there is a general tendency common to both Eumenidae and Vespoidea.

Since MacArthur and Wilson (1967) reformulated the area-species relation in the light of new biogeographical theory, many archipelagos of the world have been resurveyed with this view point. Several animal groups have been analyzed in the Ryūkyū Archipelago regarding the area-species relation (e.g., chrysomelid beetles by Kimoto, 1982; land snails by Tomiyama, 1983, and Kurozumi, 1984; ants by Terayama & Yamane, 1984). The results of all these studies fairly well fitted Arrhenius' equation, $S=cA^Z$.

Kimoto (1982) made a further analysis, comparing the area-species relation between

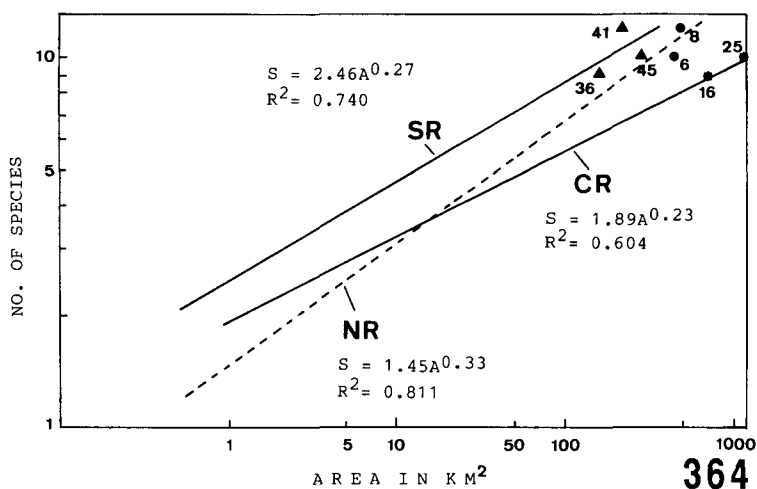
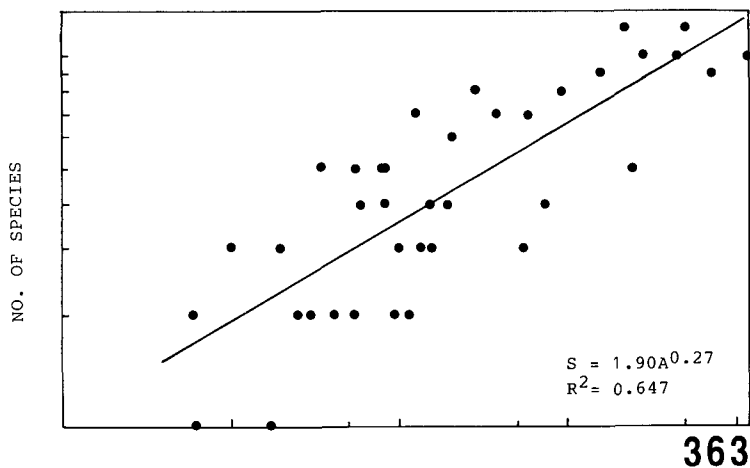
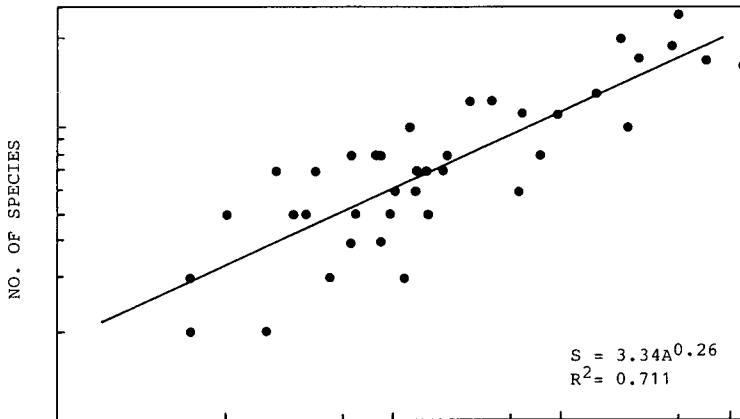

Fig. 363. Area-species relation for the Ryūkyū Eumenidae. Islands listed in Table 5 are plotted, but most islets of the Tokara (10-13) and Daitō (51, 52) groups are omitted because they are not sufficiently surveyed.

Fig. 364. Area-species relation for the Ryūkyū Eumenidae. Regression lines are separately drawn for N., C. and S. Ryukyus (NR, CR and SR respectively). 6, Tane-ga-shima; 8, Yaku-shima; 16, Amami-ōshima; 25, Okinawa-jima; 36, Miyako-jima; 41, Ishigaki-jima; 45, Iriomote-jima.

the South Kurile Islands (situated around 44°N) and the Ryūkyū Islands. He discovered that the number of chrysomelid species in the Ryukyus was constantly larger than that of Southern Kuriles. In general, the number of insect species in relation with the area may be larger in warmer regions. In this respect the regression lines in Figs. 364 and 366 are quite interesting.

The fact that the largest species number is found in the S. Ryukyus seems to be consistent with Kimoto's argument. The species numbers for the C. Ryukyus, however, are not definitely larger than those for the N. Ryukyus. The large islands in the C. Ryukyus (Okinawa-jima; Amami-ōshima) hold smaller species numbers than do slightly smaller



365

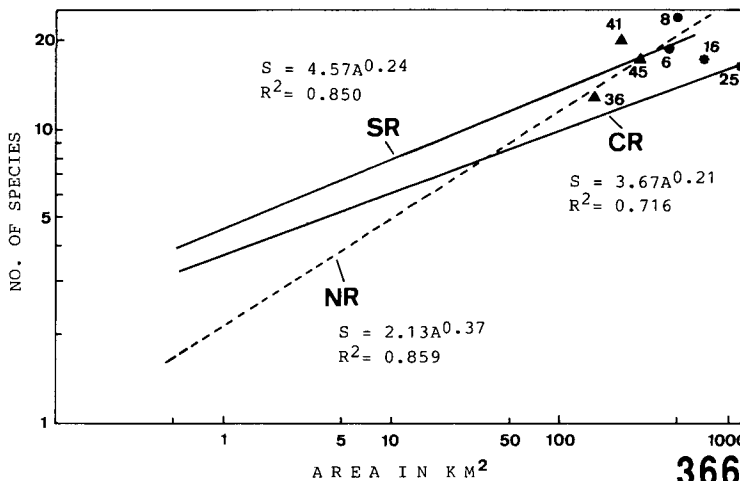

366

Figs. 365. Area-species relation for the Ryūkyū Vespoidea.

Figs. 366. Area-species relation for the Ryūkyū Vespoidea. Regression lines are separately drawn for N., C. and S. Ryukyus. For abbreviations and island code see Fig. 364.

islands in the N. Ryukyus (Yaku-shima; Tane-ga-shima). As a result the curves for these two regions cross between 10-40 km². The geological history and location of these island groups may be responsible for this. First, Yaku-shima and Tane-ga-shima are typical continental islands and relatively close to the colonizing source (Kyûshû), while some small islands in this region such as islands of Mi-shima and Uji groups, remote from colonizing source, are of volcanic origin or have long been isolated. All this no doubt contributes to the larger values of *z*, or slope of curve (0.33 for Eumenidae; 0.36 for Vespoidea).

On the other hand, the Central Ryukyus are less easily accessible by the immigrants, so the equilibrium species number is expected to be relatively low. However, the small islands in this island group are not so remote from the source regions (in this case Okinawa-jima and Amami-ôshima) or from each other (or at least clustered by means of stepping stones). As MacArthur and Wilson (1967) pointed out, under these situations *z* may be decreased, the area-species curve having a low slope. The low values of *z* for the S. Ryukyus (0.26 for Eumenidae; 0.23 for Vespoidea) can be explained in a similar way. However, although such analyses are not made, land snails (Tomiyama, 1983) and ants (Terayama & Yamane, 1984) do not seem consistent with the present results.

5.4. *Geographical replacement.* The small islands are generally poor in eumenid fauna as discussed above, and counterparts of supposed competing species are often lacking (here, species with similar nesting behaviors are supposed to be competing).

In the N. Ryukyus two species (*frauenfeldi* and *chinensis*) of *Stenodynerus* are common, but coexist only on larger islands (more than 30 km² in area). The Uji and Mi-shima groups completely lack *S. frauenfeldi*, while on Mage-shima only *S. chinensis* has been collected (Fig. 47). In this connection, however, other small islands in the other parts of Japan have not yet been carefully surveyed. In the C. Ryukyus also, *S. frauenfeldi* is paired with another closely related species, *rufomaculatus*, and they are completely allopatric. On even large islands such as Amami-ôshima and Okinawa-jima one of them is absent. However, my observations on Yoron-tô and Amami-ôshima suggest that *rufomaculatus* cannot be an all-out competitor with *frauenfeldi*, because the former is mostly confined to the coast, while the latter is collected also inland. The above case of supposed geographical replacement, therefore, is open to criticism.

In the N. Ryukyus, *Rhynchium quinquecinctum* has been collected only on Naka-no-shima of the Tokara group. Although extending as north as Niigata-ken, Honshû, this species prefers warmer regions and is generally much rarer than *Anterhynchium flavomarginatum*, a supposed competitor, in any part of Japan proper, while it is quite common in Southeast Asia including Taiwan. In general, on islands rare species are expected to go extinct more easily than common species even without any competitive encounter. Further, most of the small islands in the C. and S. Ryukyus harbor both *R. quinquecinctum* and *A. flavomarginatum*, thus the possibility of geographical replacement by means of competitive exclusion is implausible in this case. *Euodynerus dantici* is also completely lacking on the islands of the N. Ryukyus. This species has a similar distribution pattern as *R. quinquecinctum*, being much rarer than the supposed competitor (*Euod. nipanicus*) in temperate Japan, while common in the S. Ryukyus and Taiwan. Although competition might be partly responsible for the lack of *R. quinquecinctum* and *Euod. dantici* in the N. Ryukyus, an alternative explanation (e.g., extinction by chance) cannot be excluded.

A case of supposed geographical replacement has been reported for large carpenter

bees (*Xylocopa*) (Yamane et al., 1983; Yamane, 1986). The four Ryukyu forms are very closely related and completely allopatric, but distribution pattern is not of a typical chessboard (cf. MacArthur, 1972). If these forms are distinct species (not subspecies of the same species), the complete allopatric pattern is best explained by competitive exclusion, though geological, topographical and climatic factors also might have played roles in the formation of the present distribution pattern. Yamane (1986) suggested a chessboard pattern for two social wasps of the subgenus *Megapolistes* in the Ryukyus. In this case the two species (*jadwigae* and *rothneyi*) are similarly common on the Japanese mainlands and similarly uncommon on Taiwan. After all, competitive exclusion cannot be excluded for the lack of counterparts on many islands in the various parts of the Ryukyus (14 out of the 26 islands studied).

5.5. *Regional convergence.* On the Okinawa Islands, C. Ryukyus, several aculeate species have exceptionally dark body markings. For example, *Polistes rothneyi*, usually characterized by bright yellow markings in Japan and Taiwan, is often mistaken on Okinawa-jima by its extremely dark body for *P. jadwigae*, which is usually darker than *P. rothneyi*, even by professional entomologists. The Okinawa form of *P. japonicus* closely parallels *P. rothneyi*. In Eumenidae, *Anterhynchium flavomarginatum*, *Rhynchium quinquecinctum* and *Okinawepipona kogimai* are characterized by dark body markings compared with the forms of other parts of Japan. On the other hand much smaller species such as *Stenodynerus* spp. and some Oriental elements, that are supposed to have immigrated recently, are not affected in color pattern at all.

The forms of the S. Ryukyus of the species above mentioned are without exception marked with bright yellow (*O. kogimai* does not occur in the S. Ryukyus). Furthermore, body markings themselves are much more extensive so that sometimes the wasps look entirely yellow. Some sphecids and pompilids are also extensively yellow-maculated.

The forms of these vespid species in the N. Ryukyus, Amami Islands and Taiwan are, roughly speaking, intermediate in coloration between those of the Okinawa group and the S. Ryukyus. All this is not consistent with a general view that forms of warmer regions have paler or brighter body markings. Apart from the real cause, the regional convergence illustrated above is best explained by Müllerian mimicry as suggested by Yamane (1988).

REFERENCES

- Azuma, S. (ed.) 1987. Field Guide-book to the Insects of Okinawa. Vol. 3. 242 pp. Okinawa Shuppan, Urazoe. [In Japanese.]
- Azuma, S. & M. Kinjo. 1987. Check-list of the Insects of Okinawa. 421 pp. Biol. Soc. Okinawa.
- Baba, K. 1935. Some hymenopterous insects from Sado Island. *Mushi* (Fukuoka), 8: 83-85. [In Japanese.]
- Baba, K. 1937. Natural enemies of *Discoelius japonicus*. *Mushi* (Fukuoka), 10: 6. [In Japanese.]
- Bequaert, J. 1918. A revision of the Vespidae of the Belgian Congo based on the collection of the American Museum Congo Expedition, with a list of Ethiopian diplopterous wasps. *Bull. Amer. Mus. Nat. Hist.* 39: 1-384.
- Bequaert, J. 1921. Description d'une espece Congolaise de genre "*Montezumia*" (Hymènoptères, Vespides) suivie de remarques taxonomiques sur ce groupe. *Rev. Zool. Afr.* 9: 235-251.
- Bequaert, J. 1926. The genus *Eumenes*, Latreille, in South Africa, with a revision of the Ethiopian species (Hymenoptera). *Ann. South Afr. Mus.* 23: 483-577.
- Bequaert, J. 1928. A study of certain types of diplopterous wasps in the collection of the British Museum. *Ann. Mag. Nat. Hist.* (10)2: 138-176.
- Blüthgen, P. 1938a. Die Eumeniden-Gattung *Allodynerus* Blüthg. 1938 (Hym., Vespidae). *Zool. Anz.* 150: 50-

- Blüthgen, P. 1938b. Beiträge zur Kenntnis der paläarktischen Eumeniden (Hym. Vespidae). Deutsch. Entomol. Zeitschr. 1938: 434-496.
- Blüthgen, P. 1938c. Systematisches Verzeichnis der Faltenwespen Mitteleuropas, Skandinaviens und Englands. Konowia 16: 270-295.
- Blüthgen, P. 1943. Taxonomische und biologische Notizen über paläarktische Faltenwespen (Hym. Vespidae). Stett. Entomol. Ztg. 104: 149-158.
- Blüthgen, P. 1961. Die Faltenwespen Mitteleuropas (Hymenoptera, Diptoptera). 248 + ii pp. Akademie-Verlag, Berlin.
- Bohart, R.M. & L.A. Stange. 1965. A revision of the genus *Zethus* Fabricius in the Western Hemisphere (Hymenoptera: Eumenidae). Univ. Calif. Publ. Entomol. 40: 1-208.
- Carpenter, J.M. 1982. The phylogenetic relationships and natural classification of the Vespoidea (Hymenoptera). Syst. Entomol. 7: 11-38.
- Carpenter, J.M. 1986. A synonymic generic checklist of the Eumenidae (Hymenoptera: Vespidae). Psyche, 93: 61-90.
- Carpenter, J.M. & J.M. Cumming. 1985. A character analysis of the North American potter wasps (Hymenoptera: Vespidae; Eumeninae). J. Nat. Hist. 19: 877-916.
- Carpenter, J.M. & M.C. Day. 1988. Nomenclatural notes on Polistinae (Hymenoptera: Vespidae). Proc. Entomol. Soc. Wash. 90: 323-328.
- Cumming, J.M. & F.L. Leggett. 1985. Cephalic foveae of eumenine wasps (Hymenoptera: Vespidae). J. Nat. Hist. 19: 1197-1207.
- Dalla Torre, K.W. von, 1904. Hymenoptera, Fam. Vespidae. In: P. Wytsma (ed.), Genera Insectorum. Vol. 19. 108 pp.
- Das, B.P. & V.K. Gupta. 1989. The Social Wasps of India and the Adjacent Countries. 292 pp. Assoc. Stn. Oriental Ins., Gainesville.
- Eickwort, G.C. 1981. Presocial insects. In: H.R. Hermann (ed.) Social Insects. Vol. 2. Academic Press, N.Y. Pp. 199-280.
- Ejima, M. et al. 1981. "A list of insects from the Gotô Islands". In: Biol. Soc. Nagasaki-ken (ed.), Natural History of the Gotô Islands, Japan. Pp. 247-332. [In Japanese.]
- Endou, N. 1977. A record of *Anterhynchium flavomarginatum micado* Kirsch (Hymenoptera, Vespidae) from central region of Hokkaidô. Kontyu (Tôkyô) 45: 11.
- Enslin, E. 1921. Beiträge zur Kenntnis der Hymenopteren II. Deutsch. Entomol. Zeitschr. 1921: 279-285.
- Enslin, E. 1922. *Lionotus delphinalis* Gir., eine für Deutschland neue Faltenwespe und ihre Biologie. Konowia 1: 241-253.
- Esaki, T. et al. 1938. Insectorum Japonicorum Illustratio Iconographia Coloribus ad Naturam Depicta. Sanseidô, Tôkyô. Pp. 359-360, pl. 161. [In Japanese.]
- Esaki, T. et al. (eds.), 1950. Iconographia Insectorum Japonicorum. 2nd. ed. pp. 1453-1457. Hokuryûkan, Tôkyô. (In Japanese.)
- Evans, H.E. & M.J. West Eberhard. 1970. The Wasps. vi + 265 pp. David & Charles, Newton Abbot.
- Gauld, I. & B. Bolton. (eds.) 1988. The Hymenoptera. xi + 332 pp. Oxford Univ. Press, London.
- Giordani Soika, A. 1941. Studi sui vespidi solitari. Boll. Soc. Venez. Stor. Nat. 2: 1-149.
- Giordani Soika, A. 1960. Notulae vespilogicae 4-9. Boll. Mus. Civ. Venez. 11 (1958): 35-102.
- Giordani Soika, A. 1970. Notulae vespilogicae 28. Nuovi *Allodynerus*. Boll. Soc. Entomol. Ital. 102: 150-152.
- Giordani Soika, A. 1972. Notulae vespilogicae 32. Nuovi Eumenidi Indomalesi. Boll. Soc. Entomol. Ital. 104: 99-110.
- Giordani Soika, A. 1973. Notulae vespilogicae 35. Descrizione di nuovi eumenidi. Boll. Mus. Civ. Stor. Nat. Venez. 24: 97-131.
- Giordani Soika, A. 1976. Vespidi ed eumenidi raccolti in Corea (Hymenoptera). Ann. Hist.-Nat. Mus. Nat. Hung. 68: 287-293.
- Giordani Soika, A. 1978. Tabella per l'identificazione dei generi Europei della famiglia Eumenidae (Hym. Vespidae). Soc. Venez. Sc. Nat.-Lavor 3: 30-41.
- Giordani Soika, A. 1982. Vespidi ed Eumenidi raccolti in Corea (Hymenoptera) 2. Folia Entomol. Hung. 43: 39-41.
- Giordani Soika, A. 1986a. Eumenidi di Okinawa e delle Filippine raccolti da J. Kojima. Boll. Mus. Civ. Stor.

Nat. Venez. 35: 67-89.

- Giordani Soika, A. 1986b. Eumenidi paleartici nuovi o poco noti. Boll. Mus. Civ. Stor. Nat. Venez. 35: 91-162.
- Goodpasture, C. 1974. Karyology and taxonomy of some species of eumenid wasps (Hymenoptera: Eumenidae). J. Kansas Entomol. Soc. 47: 364-372.
- Goukon, K. 1983a. Aculeata of Mt. Zao. Gensei (Kôchi), 43: 13-24. [In Japanese.]
- Goukon, K. 1983b. On the flower-visiting of vespoid wasps, with the list of vespoid wasps from Sendai Plain, Miyagi Prefec., Honshû, Japan. Gensei (Kôchi), 43: 33-43. [In Japanese.]
- Goukon, K. 1983c. Ecological studies on *Ancistrocerus densepilosellus* Cameron. 1. Nest structure and parasitoids. Abstr. 43th Annu. Meeting Entomol. Soc. Jpn. P. 46. [In Japanese.]
- Goukon, K. 1984. Ditto 2. Cell-constructing behavior. Tôhoku Konchû (Morioka), 22: 6. [In Japanese.]
- Gusenleitner, J. 1979. Bemerkenswertes über Faltenwespen 7. Nachrichtenblatt Bayer. Entomol. 28: 60-63.
- Gusenleitner, J. 1981. Revision der paläarktischen *Stenodynerus*-Arten (Hymenoptera, Eumenidae). Polsk. Pismo Entomol. 51: 209-305.
- Gusenleitner, J. 1988. Ueber Eumenidae aus Thailand, mit einer Bestimmungstabelle für orientalische *Labus*-Arten (Hymenoptera, Vespoidea). Linzer Biol. Beitr. 20: 173-198.
- Habu, N. 1986. "Colonization of Ogasawara Islands by insects". In: Kiritani, K. (ed.), Insects of Japan - Ecology of invasion and disturbance. Tôkai Univ. Press., Tôkyô. Pp. 107-114. [In Japanese.]
- Haneda, Y., I. Nishino, C. Nozaka, H. Okuno, T. Tano, H. Kurokawa, & T. Murota. 1985. Hymenoptera. In: Insect Fauna of Fukui Prefecture. Pp. 246-328. [In Japanese.]
- Hanzawa, S. 1935. Topography and geology of the Riukiu Islands. Sci. Rep. Tôhoku Imp. Univ. (Geology), 17: 1-61, 15 pls.
- Higuma, S. 1987. Biogeographical studies of the insect-fauna of Sado Island. Nat. Hist. Jpn. 1 (9): 35-40. [In Japanese.]
- Hisamatsu, M., S. Yamane, & S. Watahiki. 1986. Eumenid wasps in Ibaraki Prefecture (Hymenoptera, Eumenidae). Bull. Fac. Educ. Ibaraki Univ. (Nat. Sci.) 35: 45-64. [In Japanese.]
- Ikeda, K. 1984. "Introduction to the insect biogeography 2". Gekkan Mushi (Tôkyô), 165: 2-10. [In Japanese.]
- Ikehara, S. 1966. Distribution of termites in the Ryûkyû Archipelago. Bull. Arts Sci. Div. Univ. Ryukyus, 9: 49-178.
- Ikehara, S. & M. Shimojana. 1971. The terrestrial animals of Senkaku Islands. In: Senkaku-rettô Gakujutsu-chôsa Hôkokusho. Pp. 85-140. [In Japanese.]
- Ikudome, S. 1989. A revision of the family Colletidae of Japan (Hymenoptera: Apoidea). Bull. Inst. Minami-Kyûshû Reg. Sci. Kagoshima Women's Junior College, 5: 43-314.
- Ikudome, S. & Sk. Yamane. 1983. Vespoid wasps from Kôchi Pref., Shikoku, Japan (Hymenoptera). Gensei (Kôchi), 43: 51-54. (In Japanese.)
- Imadaté, G. & K. Kaneda. 1984. Protura (Insecta) from Sado Island. Trans. Essa Entomol. Soc. (Niigata), 58: 11-19. [In Japanese with English summary.]
- Ishikawa, R. 1965. Vespidae. In: S. Asahina et al. (eds.). Iconographia Insectorum Japonicorum. Colore Naturali Edita. Vol. 3. Hokuryûkan, Tôkyô. Pp. 291-297, pls. 146-149. [In Japanese.]
- Ishikawa, R. 1970. On some noteworthy vespoid wasps of Tsushima. Mem. Nat. Sci. Mus. Tôkyô 3: 269-272, pl. 22. [In Japanese with English summary.]
- Itino (Ichino), T. 1986a. Comparison of life tables between the solitary eumenid wasps *Anterhynchium flavomarginatum* and the subsocial eumenid wasp *Orancistrocerus dreuseni* to evaluate the adaptive significance of maternal care. Res. Popul. Ecol. 28: 185-199.
- Itino, T. 1986b. "Resource utilization and populations in two eumenid wasps". Kotaigunseitaigakkai-kaihô, 41: 15-18. [In Japanese.]
- Itino, T. 1986c. "Ecology of eumenid wasps". Shizengau-kenkyû, 1: 85-94. [In Japanese.]
- Iwata, K. 1938a. Habits of four species of *Odynerus* (*Ancistrocerus*) in Japan. Tenthredo, 2: 19-32.
- Iwata, K. 1938b. Habits of eight species of Eumenidae (*Rhynchium*, *Lionotus*, and *Symmorphus*) in Japan. Mushi (Fukuoka), 11: 110-132.
- Iwata, K. 1939a. Habits of some solitary wasps in Formosa 1. Trans. Nat. Hist. Soc. Formosa, 29: 39-47. [In Japanese.]
- Iwata, K. 1939b. Ditto 2. Trans. Nat. Hist. Soc. Formosa, 29: 67-74. [In Japanese.]
- Iwata, K. 1939c. Biology of *Macrosiagon nasutum* Thunberg with some biological notes on *Macrosiagon bipunctatum* Fabricius in Japan. Trans. Kansai Entomol. Soc. 9: 44-53. [In Japanese.]

- Iwata, K. 1942. Comparative studies on the habits of solitary wasps. *Tenthredo*, 4: 1-146, pls. 1-5.
- Iwata, K. 1935. Biology of *Eumenes* in Japan (Hymenoptera: Vespidae). *Mushi* (Fukuoka), 25: 25-46, pl. 2.
- Iwata, K. 1963. New records and descriptions of the prey of some Japanese hunting wasps. *Kontyû* (Tôkyô), 31: 194-197. [In Japanese.]
- Iwata, K. 1964. Bionomics of non-social wasps in Thailand. *Nat. Life S.E. Asia*, 3: 323-383.
- Iwata, K. 1971. Evolution of Instinct. Comparative Ethology of Hymenoptera. 503 pp. Mano-shoten, Kanagawa-ken. (In Japanese; English translation by Smithsonian Institution and National Science Foundation, Washington, D.C., 529 pp., 1976.)
- Iwata, K. 1978a. Konchû wo Mitsumete 50 Nen. Vol. 1. 331 + xi pp. Asahi-shinbun-sha, Tôkyô. Eumenidae: 92-103 (*Ancistrocerus*); 195-212 (*Eumenes*).
- Iwata, K. 1978b. Ditto. Vol. 2. 310 + xiv pp. Eumenidae: 180-192 (*Symmorphus*).
- Iwata, K. 1979. Ditto. Vol. 3. 269 + xxiv pp. Eumenidae: 51-73 (*Euodynerus nipanicus*).
- Iwata, K. 1980a. Ditto. Vol. 4. 232 + xxix pp. Eumenidae: 38-49 (*Stenodynerus*).
- Iwata, K. 1980b. Shizen-kansatsusha no Shuki. Vol. 1. 285 + xi pp. Asahi-shuppan-sha, Tôkyô. Eumenidae: 176-180 (*Pseumenes*). First published in 1975.
- Iwata, K. 1980c. Ditto. Vol. 2. 263 + xi pp. Eumenidae: 20-37 (*Eumenes*, *Oreumenes* and *Delta*); 180-190 (common Japanese species); 191-199 (*Rhynchium*). First published in 1975.
- Iwata, K. 1982. Japanese Wasp and Bee Life Illustrated Phylogenetically. 162 pp. Kôdansha, Tôkyô. [In Japanese.]
- Iwata, K. 1983. Shin-konchû-ki. xv + 294 pp. Asahi-shinbun-sha, Tôkyô. Eumenidae: 178-206 (*Orancistrocerus*).
- Jørgensen, P. 1942. Biological observations on some solitary vespides. *Entomol. Medd.* 22: 299-335.
- Kamiya, K. 1931. On the insects from Izu-ôshima. A preliminary report. *Kagaku-no-nôgyô*, 12 (2): 19-25. [In Japanese.]
- Kamiya, K. 1934. Insects of To-shima. *Kontyû* (Tôkyô), 8: 111-113. [In Japanese.]
- Katayama, H. 1935. Biological observations on *Eumenes decoratus* Smith. 1. *Kansai Konchû Zasshi*, 3: 28-32. [In Japanese.]
- Katayama, H. 1936. Ditto. 2. *Kansai Konchû Zasshi*, 4: 3-7. [In Japanese.]
- Kifune, T. & Y. Maeta. 1978. A new *Pseudoxenos* (Strepsiptera: Stylopidae) parasitic on *Stenodynerus* (Hymenoptera: Vespidae) from Japan. *Kontyû* (Tôkyô), 46: 416-428.
- Kifune, T. & Sk. Yamane. 1985. Two new species of the genus *Paraxenos* (Strepsiptera, Stylopidae) and records of stylopized Sphecidae and Eumenidae (Hymenoptera) from the Ryukyus, Japan. *Kontyû* (Tôkyô), 53: 49-58.
- Kim, C.-W. 1970. Illustrated Encyclopedia of Fauna and Flora of Korea. Vol. 11, Insecta (III). Hymenoptera. 892 pp. [In Korean.]
- Kimoto, S. 1979. Minami no Shima no Ikimonotachi [Island Biology]. vi + 203 pp. Kyôritsu-shuppan, Tôkyô. [In Japanese.]
- Kimoto, S. 1982. Zoogeography and ecology of the Ryûkyû Archipelago with special reference to leaf beetles (Coleoptera: Chrysomelidae). *Entomol. General.* 8: 51-58.
- Krombein, K.V. 1967. Trap-nesting Wasps and Bees: Life Histories, Nests, and Associates. vi + 570 pp. Smithsonian Press, Washington D.C.
- Krombein, K.V. 1978. Biosystematic studies of Ceylonese wasps 3. Life history, nest and associates of *Paraleptomenes mephitis* (Cameron)(Hymenoptera: Eumenidae). *J. Kansas Entomol. Soc.* 51: 721-734.
- Krombein, K.V. 1979. Superfamily Vespoidea. In: Catalog of Hymenoptera in America North of Mexico. Vol. 2. Smithsonian Institution, Washington DC. Pp. 1469-1522.
- Kuroiwa, H. 1926. Provisional list of the Hymenoptera collected in Loochoo Islands during the years 1905-1907. *Trans. Nat. Hist. Soc. Formosa*, 16: 138-141.
- Kurosawa, Y. 1976. Beetle fauna of the Bonin Islands, with a consideration on its origin and constitution (2). *Gekkan Mushi* (Tôkyô), 69: 3-8. [In Japanese.]
- Kurosawa, Y. 1978. Phylogeny and distribution of *Lucanus gamunus* Sawada et Y. Watanabe (Coleoptera, Lucanidae), endemic to the Izu Islands, central Japan. *Mem. Natn. Sci. Mus. Tôkyô*, 11: 141-153. [In Japanese with English summary.]
- Kurozumi, T. 1984. Biogeography of the land snails in the Ryûkyû Islands. 246 pp. Unpublished manuscript. [In Japanese with English summary.]

- Kurzenko, N.V. 1978. Superfamily Vespoidea. In: Medvedeva, G.S. (ed.), Key to the Insects of the European Part of the USSR. Vol. III. Hymenoptera. Part 1. Leningrad. Pp. 147-173. [In Russian.]
- Kurzenko, N.V. 1980. Contribution to the basic direction of evolution and phylogeny of the family Eumenidae (Hymenoptera: Vespoidea). In: Krassilov, B.A. (ed.) Parallelism and Direction in Evolution of Insects. Akademii Nauk SSSR, Vladivostok. Pp. 88-114. [In Russian.]
- Kurzenko, N.V. 1984a. New and little-known species of the genus *Eumenes* Latr. (Hymenoptera, Eumenidae) from southern parts of eastern Siberia and the Far East. In: Systematics of Insects of the Far East. Akademii Nauk SSSR, Vladivostok. Pp. 116-119. [In Russian.]
- Kurzenko, N.V. 1984b. *Rhynchium* Spin. - a solitary diplopterous genus new to the fauna of USSR. In: Systematics of Insects of the Far East. Akademii Nauk SSSR, Vladivostok. Pp. 120-121. [In Russian.]
- Lee (Li), T.-S. 1982. Hornets from Agricultural Regions of China (Hymenoptera: Vespoidea). ii + vi + 255 pp., 6 pls. Agric. Publ. House, Beijing. [In Chinese.]
- Lee, T.-S. 1984. Using vespid wasps to control injurious caterpillars in cotton fields. Proc. Chin. Acad. Sci. - U.S. Nat. Acad. Sci. Joint Symp. Biol. Control Ins., Beijing. Pp. 368-372.
- Lee, T.-S. 1985. Hymenoptera: Vespoidea. Econ. Ins. Fauna China, Fasc. 30. 150 pp., 12 pls. Science Press, Beijing. [In Chinese.]
- Lee, T.-S., K.-K. Ho, C.-T. Lee, & C.-W. Shih. 1986. Using Vespid Wasps in Controlling Agricultural Pests. 88 pp. [In Chinese.]
- Lee, T., T.-F. Wang, & H.-J. Tung. 1975. A preliminary study on the biology and use of *Rhynchium brunneum* Fabricius. Acta Entomol. Sinica. 18: 151-155. [In Chinese.]
- Liu, C.L. 1936. A bibliographic and synonymic catalogue of the Vespoidea of China, with a cross-referring index for the genera and species (I). Peking Nat. Hist. Bull. 11: 91-114.
- Liu, C.L. 1941. Revisional studies of the Vespidae of China 1. The genus *Pareumenes* Saussure, with descriptions of six new species (Hymenoptera: Eumeninae). Notes Entomol. Chin. 8: 245-289.
- MacArthur, R.H. 1972. Geographical Ecology. Harper & Row, N.Y.
- MacArthur, R.H. & E.O. Wilson. 1967. The Theory of Island Biogeography. xi + 203 pp. Princeton Univ. Press, Princeton.
- Maeta, Y. 1963. Some biological notes on *Pseudoxenos iwatai* Esaki (1). Its biology and life history. Kontyû (Tôkyô) 31: 1-15, pls. 31, 32. [In Japanese with English summary.]
- Maeta, Y. 1980. "New distribution records of *Pseudoxenos iwatai* Esaki." Tôhoku-konchû (Morioka), 18: 4. [In Japanese.]
- Maeta, Y. 1985. "Distribution of the four *Melittobia* species in Japan". Tôhoku-konchû (Morioka), 23: 4. [In Japanese.]
- Maeta, Y. & Sk. Yamane. 1974. Host records and bionomics of *Melittobia japonica* Masi (Hymenoptera, Eulophidae). Bull. Tôhoku Nat. Agric. Exp. Stn. 47: 115-131. [In Japanese with English summary.]
- Malyshev, S.I. 1968. Genesis of the Hymenoptera and the Phases of Their Evolution. viii + 319 pp. Methuen & Co. LTD, London.
- Masuda, H. 1937. Biological notes on *Discoelius japonicus* Pérez. Mushi (Fukuoka), 9: 81-109, pls. 7-9. [In Japanese.]
- Matsumura, S. 1911. Thousand Insects of Japan. Suppl. 3. Tôkô-shoin, Tôkyô. Pp. 98-147, pls. 38-41. [In Japanese.]
- Matsumura, S. 1930. The Illustrated Thousand Insects of Japan. Vol. 2 (Hymenoptera). 198+89+8 pp, 18 pls. Tôkô-shoin, Tôkyô. [In Japanese and English.]
- Matsumura, S. 1931. 6000 Illustrated Insects of Japan-Empire. Tôkô-shoin, Tôkyô. Pp. 10-33. [In Japanese.]
- Matsumura, S. u. T. Uchida. 1926. Die Hymenopteren-Fauna von den Riukiu-Inseln. Ins. Matsum. 1: 32-52, 63-77, pl. 3.
- Matsuura, M. 1966. Notes on the hibernating habits of the genus *Vespa* in Japan (Hymenoptera, Vespidae). Kontyû (Tôkyô), 34: 52-67. [In Japanese with English summary.]
- Matsuura, M. & Sk. Yamane. 1984. Comparative Ethology of the Vespine Wasps. Hokkaido Univ. Press, Sapporo. xvi + 428 pp. [In Japanese with English summary.]
- Meade-Waldo, M.A. 1914. A revision of the species of the genus *Odynerus* (Hymenoptera) occurring in the Ethiopian Region. Trans. Entomol. Soc. Lond. 1914: 485-520, 1 pl.
- Mezaki, S. 1980. Parallel zonation of high and low islands in the Ryûkyû Island Arc. Geological Studies of the Ryûkyû Is. 5: 91-101. [In Japanese.]

- Mezaki, S. 1983. Nantô, Ryûkyû-ko no chimei to chiiki-kubun. *In*: Nantô no Chimei. Nantô Chimei Kenkyû Center. Pp. 19-25. [In Japanese.]
- Miyata, A. 1977. A list of insects from Chikuzen-Okino-Shima. *In*: Biol. Soc. Nagasaki-ken (ed.), Natural History of the Islands of Iki. Pp. 561-594. [In Japanese.]
- Munakata, M. 1987. "Records of bees and wasps from Okushiri Island". *Hym. Communication (Mishima)*, 27: 35-38. [In Japanese.]
- Munakata, M. & S. Yamane. 1970. Social vespid wasps from the southern part of the Oshima Peninsula and the Okushiri Islands, northern Japan (Hymenoptera, Vespidae). *Kontyû (Tôkyô)*, 38: 281-291.
- Nagase, H. 1981. Aculeate Hymenoptera of Kagoshima Prefecture. *Satsuma (Kagoshima)*, 86: 253-289. [In Japanese.]
- Nagase, H. 1982. Wasps and bees of southern Kyûshû. *Hym. Communication (Mishima)*, 14: 57-78. [In Japanese.]
- Nakamine, K. 1987. "Phylogenetic relationships of the Japanese genera of Eumenidae". 54 pp. Unpublished manuscript. [In Japanese.]
- Nakane, T. 1970. The insects of the Bonin and the Volcano Islands. *In*: Min. Educ. Cul. & Age. Cul. Aff. Japan (eds.), The Nature of the Bonin and the Volcano Islands. Pp. 15-32. [In Japanese with English summary.]
- Nakatani, Y. 1988. "Karyology of some Japanese species of Vespoidea, with reference to its evolutionary importance". 62 pp. Unpublished manuscript. [In Japanese.]
- Nambu, T. 1977. "*Symmorphus* species in my collection". *Hym. Communication (Mishima)*, 5: 2-4. [In Japanese.]
- Nambu, T. 1978. Hymenoptera of Saitama. *In*: Saitama Prefecture Board of Education (ed.), The Fauna of Saitama Prefecture. Pp. 177-211. [In Japanese.]
- Nielsen, E.T. 1932. Sur les habitudes des Hyménoptères aculeates solitaires. 2. *Entomol. Meddr.* 18: 84-174, f. 1-28.
- Ogata, K. & H. Nagase. 1987. "Aculeate Hymenoptera of Tanega-shima Island". *Satsuma (Kagoshima)*, 36: 1-15. [In Japanese.]
- Ohgushi, R. & H. Tokumoto. 1986. Terrestrial fauna of Hegura-jima Island and Nanatsu-jima Islands, Noto Province. *Bull. Jpn. Sea Res. Inst. Kanazawa Univ.* 18: 1-20. [In Japanese.]
- Ônuma, T. 1989a. "Three tube-nesting wasps in Sado". *Trans. Essa Entomol. Soc. (Niigata)*, 67: 101-106. [In Japanese.]
- Ônuma, T. 1989b. "On *Symmorphus diens* in Okutadami (Gimpei-zan)". *Trans. Essa Entomol. Soc.* 67: 107-110. [In Japanese.]
- Ônuma, T. 1989c. "Nesting in abandoned mud nests of *Oreumenes decoratus* by *Anterhynchium flavomarginatum*". *Trans. Essa Entomol. Soc.* 67: 111-115. [In Japanese.]
- Ôtsuka, I. 1984. Hymenoptera of Kumamoto Pref. (II). *Kumamoto Konchû-dôkôkai Kaihō* 30(1): 6-17. [In Japanese.]
- Okada, K. 1981. "Wasps and bees from the southern part of Awaji-shima (II)". *Parnassius*, 25: 13-16. [In Japanese.]
- Pérez, J. 1905. Hyménoptères recueillis dans le Japon central, par M. Harmand, ministre plénipotentiaire de France à Tokio 2. *Bull. Mus. Hist. Nat. Paris*, 11: 79-86.
- Piel, O. 1935. Biologie de *Pareumenes quadrispinosus* Saussure (Hyménoptères Vespides) et de ses parasites, en particulier: *Calosota chinensis* Ferriere. *Notes Entomol. Chin.* 2: 105-139.
- Richards, O.W. 1962. A Revisional Study of the Masarid Wasps (Hymenoptera, Vespoidea). 294 pp. British Museum (NH), London.
- Richards, O.W. 1973. The subgenera of *Polistes* Latreille (Hymenoptera, Vespidae). *Rev. Bras. Entomol.* 17: 85-104.
- Sato, O. 1963a. Eumenid wasps of Osaka Prefecture. *Nature Study (Osaka)*, 9: 88-91. [In Japanese.]
- Sato, O. 1963b. Additional notes on the Eumenidae of Osaka Prefecture. *Nature Study (Osaka)*, 9: 109-110. [In Japanese.]
- Sato, O. 1964. On the genus *Eumenes* of Osaka. *Nature Study (Osaka)* 10: 12-14. [In Japanese.]
- Saussure, H. de, 1853. Monographie des guêpes solitaires, ou de la tribu des Euméniens. Etudes sur la Famille des Vespides. Vol. 1. 286 pp., 21 tabs.
- Saussure, H. de, 1855. Supplement a la monographie des guepes solitaires, ou de la tribu des Euméniens.

- Etudes sur la Famille des Vespides. Vol. 3. Pp. 101-352, 16 pls.
- Sawada, H. & Y. Watanabe. 1959. Insect fauna of Hachijō-kojima. J. Agric. Sci. Tôkyô Nôgyô Daigaku, 5(2): 47-62. [In Japanese.]
- Schulthess, A. von, 1908. Neue Eumeniden aus Japan (Hymen.). Mitt. Schweiz. Entomol. Ges. 11: 284-288.
- Schulthess, A. von, 1913. Vespiden aus den Stockholmer Museum. Ark. Zool. Stockholm, 8(17): 1-23.
- Schulthess, A. von, 1934. Zur Kenntnis der Odynerusarten (Vespidae, Hym.) der japanischen Subregion (China, Japan, Formosa, Philippinen). Arb. Morph. Taxon. Entomol. Berlin-Dahlem, 1: 66-103.
- Shibuya, K. 1938. Notes on the nesting-habits of *Odynerus (Ancistrocerus) shibuyai* Yasumatsu and *Crabro (Crabro) iridifrons* Pérez from Japan (Eumenidae and Crabronidae). Mushi (Fukuoka), 11: 1-10. [In Japanese.]
- Shirôzu, T. 1980. "A general view of the insect fauna of Tsushima". Gekkan Mushi, 117: 3-12. [In Japanese.]
- Shirôzu, T. & A. Miyata. 1976. "A list of insects from Tsushima". In: Biol. Soc. Nagasaki-ken (ed.), "Natural History of the Tsushima Islands, Japan". Pp. 567-764. [In Japanese.]
- Smith, F. 1852. Descriptions of some new and apparently undescribed species of hymenopterous insects from North China, collected by Robert Fortune. Trans. Entomol. Soc. London, (2)2: 33-48.
- Smith, F. 1873. Descriptions of aculeate Hymenoptera of Japan, collected at Nagasaki and Hiogo. Trans. R. Entomol. Soc. Lond. 1873: 181-206.
- Sonan, J. 1929. Some wasps and bees of Hôkotô (Pescadore Islands). Trans. Nat. Hist. Soc. Formosa, 19: 535-537. [In Japanese with English descriptions.]
- Sonan, J. 1937a. On two Formosan species of the genus *Montezumia* de Saussure (Hym. Eumenidae). Trans. Nat. Hist. Soc. Formosa, 27: 14-16.
- Sonan, J. 1937b. On the genus *Rhygchium* Spinola (= *Rhynchium* Fabricius) in Formosa (Hym. Eumenidae). Trans. Nat. Hist. Soc. Formosa, 27: 107-112.
- Sonan, J. 1938a. H. Sauter's Formosa-collection: *Polistes*, *Montezumia* and *Pareumenes* (Hymenoptera: Vespidae and Eumenidae). Arb. Morph. Taxon. Entomol. Berlin-Dahlem, 5: 66-70.
- Sonan, J. 1938b. Notes on the Vespoidea in Japan (Hymenoptera). Trans. Nat. Hist. Soc. Formosa, 28: 77-81. [In Japanese.]
- Spradbery, J.P. 1973. Wasps. An Account of the Biology and Natural History of Solitary and Social Wasps. xvi + 408 pp. Sidgwick & Jackson, London.
- Suda, H. 1979. "Notes on *Eumenes micado* and *E. samurayi* in Japan". Chiba Seibutsu-shi, 29: 10-16. [In Japanese.]
- Sunose, T. 1981. "Biogeography of two color types of *Masakimya pustulae* - The origin and range expansion of the white type -". Panmixia, 4: 1-7. [In Japanese.]
- Takara, T. 1954. Fauna of the Senkaku Islands, Ryukyus. Bull. Coll. Agric. Univ. Ryukyus, 1: 57-74. [In Japanese.]
- Takara, T. & S. Azuma. 1973. Insects of Okinawa. Gakushû-kenkyû-sha, Tôkyô. Pp. 160-181, figs. 99, 103. [In Japanese.]
- Takekuma, Y. 1971. "Biotic Insecticide: *Odynerus micado* Cameron." 32 pp. Aomori-ken Nôgyô-kenkyû Club. [In Japanese.]
- Tano, T. 1966. The aculeate Hymenoptera collected on the Island Tsushima. Mem. Fukui-kenritsu Maruoka High School, 1966: 45-49. [In Japanese.]
- Taylor, R.W., D.R. Brown & J.C. Cardale. 1985. Zoological Catalogue of Australia. Vol. 2 Hymenoptera: Formicidae, Vespoidea and Sphecoidea. 381 pp. Bureau of Flora and Fauna, Canberra.
- Terayama, M. 1982. Regional differences of the ant fauna of the Nansei Archipelago based on the quantitative method. I. Bull. Biogeogr. Soc. Jpn. 37: 1-5.
- Terayama, M. & Sk. Yamane. 1984. Ants of Yaku-shima Island, the northern Ryukyus, with reference to their altitudinal distribution (Insecta: Hymenoptera). Cons. Rep. Yaku-shima Wild. Area Kyûshû Japan. Nature Cons. Bureau Env. Agency Japan. Pp. 643-667. [In Japanese with English summary.]
- Tomiyama, K. 1983. Quantitative analyses of land snail fauna in the middle and northern parts of the Ryukyu Islands. Bull. Biogeogr. Soc. Jpn. 38: 11-22. [In Japanese with English abstract.]
- Tosawa, N. 1934. On *Eumenes* of Japan Empire. Trans. Kansai Entomol. Soc. 5: 3-16, pl. 1. [In Japanese.]
- Tosawa, N. 1936. "On some wasps of the genus *Pareumenes*." Kansai Konchû Zasshi, 4: 45-46. [In Japanese.]
- Tsuneki, K. 1961. Colour vision and figure discriminating capacity of the solitary diplopterous wasp, *Odynerus frauenfeldi* Saussure. Mem. Fac. Lib. Arts Fukui Univ. Ser. 2 (Nat. Sci.) 11: 1-72.

- Tsuneki, K. 1969. The nesting activity of *Odynerus frauenfeldi* Saussure. Life Study (Fukui), 13: 1-12. [In Japanese with English summary.]
- Tsuneki, K. 1970. Gleanings on the bionomics of the East-Asiatic non-social wasps (Hymenoptera) 7. On some species of diplopterous wasps with the description of a new species. Etizenia (Fukui), 46: 1-25.
- Tsuneki, K. 1973a. Nests of *Symmorphus captivus* (Smith). Life Study (Fukui), 17: 114. [In Japanese.]
- Tsuneki, K. 1973b. Table of nests of *Discoelius japonicus* Pérez. Life Study (Fukui), 17: 151. [In Japanese.]
- Tsuneki, T. 1976. Giordani Soika's (1975) "Revision dei *Symmorphus* del Giappone", with notes on the specimens in my collection. Hym. Communication (Mishima), 4: 17-30. [In Japanese.]
- Tsuneki, K. 1978. Nest building of *Eumenes decoratus* Smith. Hym. Communication (Mishima), 8: 35. [In Japanese.]
- Tsuneki, K. 1980. Observations on the nesting activities of *Eumenes decoratus* Smith. Hym. Communication (Mishima), 10: 9-25. [In Japanese.]
- Tsuneki, 1982. Successive observations on the nest constructing activities of the solitary Diplopterous wasp, *Eumenes decoratus* F. Smith, with its later process (Hymenoptera). Spec. Publ. Jpn. Hym. Assoc. 21: 1-17.
- Tsuneki, K. 1986. New species and subspecies of the aculeate Hymenoptera from East Asia, with some synonyms, specific remarks and distribution data. Spec. Publ. Jpn. Hym. Assoc. 32: 1-60.
- Uchida, S. et al. 1932. Iconographia Insectorum Japonicorum. 1st ed. Hokuryūkan, Tōkyō. Pp. 306-312.
- Umeya, K. 1956a. Insect fauna of the Izu Islands 3. Nii-jima. Shin-konchū (Tōkyō), 9 (3): 8-13. [In Japanese.]
- Umeya, K. 1956b. Insect fauna of the Izu Islands 4. Kōzu-jima. Shin-konchū (Tōkyō), 9(9): 34-38. [In Japanese.]
- Vecht, J. van der, 1963. Studies on Indo-Australian and East-Asiatic Eumenidae (Hymenoptera, Vespoidea). Zool. Verh. Leiden, 60: 1-116.
- Vecht, J. van der, 1966. Notes on Palearctic Eumenidae (Hymenoptera). Entomol. Berichten, 26: 161-165.
- Vecht, J. van der, 1981. Studies of Indo-Australian solitary wasps (Hymenoptera, Vespoidea, Eumenidae). Proc. Konink. Ned. Akad. Wetens. (C)84: 443-464.
- Vecht, J. van der & F.C.J. Fischer. 1972. Palearctic Eumenidae. Hym. Cat. (nov. ed.), 8: 1-199.
- Williams, F.X. 1919. Descriptions of new species and life history studies. In: Philippine Wasp Studies. Exp. Sta. Hawaii. Sugar Plant. Assoc. Pp. 19-186.
- Yamada, M. 1983. Vespid wasps from Aomori Prefecture, northern Japan. J. Aomori-ken Biol. Soc. 21: 1-5. [In Japanese.]
- Yamamuro, K. 1985. Ecological notes on a hunting wasp, *Pseumenes depressus*, with reference to the mate locating and the feeding behaviour. Gekkan Mushi (Tōkyō), 175: 34-35. [In Japanese with English summary.]
- Yamamuro, K. 1988. Observation on the mating behavior of *Delta esuriens*. Insectarium (Tōkyō), 25: 320-321. [In Japanese.]
- Yamane, Sk. 1977a. Notes on eumenid wasps from Japan and its adjacent regions (Hymenoptera: Vespidae) 1. New Entomol.(Ueda) 26: 14-18. [In Japanese.]
- Yamane, Sk. 1977b. Ditto 2. New Entomol. (Ueda), 26: 59-63.
- Yamane, Sk. 1979. Ditto 3. New Entomol. (Ueda), 28: 8-12. [In Japanese.]
- Yamane, Sk. 1981. Ditto 5. Trans. Shikoku Entomol. Soc. 15: 221-225.
- Yamane, Sk. 1982a. Ditto 4. New Entomol. (Ueda), 31: 9-14. [In Japanese.]
- Yamane, Sk. 1982b. Vespid wasps from Niigata Pref., Honshū, Japan. Trans. Essa Entomol. Soc. (Niigata), 53: 3-14. [In Japanese.]
- Yamane, Sk. 1984. Vespid fauna of Yaku-shima Island (Hymenoptera). Cons. Rep. Yaku-shima Wild. Area Kyūshū Japan. Nature Cons. Bureau Env. Agency Japan. Pp. 633-642. [In Japanese with English summary.]
- Yamane, Sk. 1986. Distribution pattern of large carpenter bees and paper wasps in the Ryukyus. In: Kimoto, S. (ed.), "Insect Biogeography of Japan". Kyōritsu-shuppan, Tōkyō. Pp. 43-49. [In Japanese.]
- Yamane, Sk. 1987a. A study of the new genus *Okinawaepipona* in the Ryukyus and Taiwan (Hymenoptera, Eumenidae). Mem. Kagoshima Univ. Res. Center S. Pac. 8: 52-57.
- Yamane, Sk. 1987b. The Vespinae of the Ryukyu Islands, Japan (Hymenoptera, Vespidae). Kontyū (Tōkyō), 55: 628-638.
- Yamane, Sk. 1988. The vespine wasps of the Ryukyu Islands, Japan. Satsuma (Kagoshima), 37: 161-174. [In

- Japanese.]
- Yamane, Sk. & J. Gusenleitner. 1982. Die *Stenodynerus*-Arten Japans (Hymenoptera: Eumenidae). Rep. Fac. Sci. Kagoshima Univ. (Earth Sci. Biol.) 15: 113-127.
- Yamane, Sk., S. Ikudome & K. Tomiyama. 1983. *Xylocopa amamensis* and *X. appendiculata* in the Northern Ryukyus, with notes on the distribution pattern of the Ryûkyû carpenter bees (Hymenoptera, Anthophoridae). Kontyû (Tôkyô), 51: 435-440.
- Yamane, Sk. & T. Tano. 1983. Studies on the genus *Anterhynchium* and its related genera of the Ryûkyû Islands, Japan (Hymenoptera, Eumenidae). Mem. Kagoshima Univ. Res. Center S. Pac. 4: 119-132.
- Yamane, Sk. & T. Tano. 1987. Studies on Japanese Eumenidae (Hymenoptera: Vespoidea). Trans. Shikoku Entomol. Soc. 18: 327-345.
- Yano, M. 1932. See Uchida, S. et al. 1932.
- Yasumatsu, K. 1930. Two unrecorded wasps from Japan and Corea, with notes on *Discoelius japonicus* Pérez. Mushi (Fukuoka), 3: xx-36, pl. 2. [In Japanese.]
- Yasumatsu, K. 1933a. Additions to the hymenopterous fauna of the Ishigaki Island. Annot. Zool. Jpn. 14: 259-271.
- Yasumatsu, K. 1933b. "Scientific name for Suzu-bachi". Mushi (Fukuoka), 6: 31. [In Japanese.]
- Yasumatsu, K. 1934. On the genus *Discoelius* of eastern Asia, with a list of the species of the genus of the world (Hymenoptera, Eumenidae). Mushi (Fukuoka), 7: 3-19, pl. 1.
- Yasumatsu, K. 1935a. Two new Eumenidae from Tsushima and Formosa (Hymenoptera). Mushi (Fukuoka), 8: 86-89.
- Yasumatsu, K. 1935b. Notes on two commonest Odynerinae in Japan (Hymenoptera, Eumenidae). Kontyû (Tôkyô), 9: 221-227. [In Japanese.]
- Yasumatsu, K. 1935c. Further notes on the hymenopterous fauna of the Yaeyama group. Annot. Zool. Jpn. 15: 33-45.
- Yasumatsu, K. 1935d. Notes on some Hymenoptera collected by Mr. Takeya on Sado Island with descriptions of two unrecorded *Megachile* species from Japan and Amami-ôshima Island. Fukuoka Hakubutsu-gaku Zasshi. 1: 384-389, pl. 1.
- Yasumatsu, K. 1938a. The subgenus *Symmorphus* Wesmael of Japan and Corea (Hym., Eumenidae, *Odynerus*). Fukuoka Hakubutsugaku Zasshi, 2: 111-116.
- Yasumatsu, K. 1938b. Beitrag zur Synonymie einiger Hymenopteren-Arten von den Ryûkyû-Inseln (Vespoidea, Sphecoidea und Apoidea). Trans. Nat. Hist. Soc. Formosa, 28: 446-447. (In Japanese.)
- Yasumatsu, K. 1938c. Two new wasps from Japan (Eumenidae and Pemphredonidae). Mushi (Fukuoka), 11: 83-86.
- Yasumatsu, K. 1938d. Les guêpes solitaires de l'île Sakhaline (Hymenoptera: Eumenidae). Ins. Matsum. 13: 14-16.
- Yasumatsu, K. 1938e. See Esaki, T. et al. 1938.
- Yasumatsu, K. 1950. See Esaki, T. et al. 1950.
- Yeo, P.F. & S.A. Corbet. 1983. Solitary Wasps (Naturalists' Handbooks 3). 65 pp. Cambridge Univ. Press.
- Yuki, Z. 1936. Some data on the insect fauna of Iwai-jima, Suoo (The insect fauna of the islands of Setonaikai, 3). Hiroshima Konchû Dôkôkai-shi, 3: 17-32. [In Japanese.]
- Zimmermann, K. 1931. Studien über individuelle und geographische Variabilität paläarktischen *Polistes* und verwandter Vespiden. Z. Morph. Oekol. Tiere, 22: 173-230, 1 pl.

APPENDIX

After the completion of the main part of this paper, J. M. Cumming (Biosystematics Research Centre, Agriculture Canada) published a world revision of the genus *Symmorphus* (Cumming, 1989, Mem. Entomol. Soc. Can., 148: 1-168). Since I have not had enough time to examine all his results, only his views concerning the Japanese forms are summarized below.

New synonymy is as follows: (*S. mutinensis auster* G.S. and *S. mutinensis yezoanus* Tsuneki) = *S. bifasciatus* (Linnaeus); (*S. ishikawai* G.S.) = *S. lucens* (Kostylev). *S. sounkionis* Tsuneki is transferred as *Ancistrocerus sounkionis* (Tsuneki) comb. nov.

INDEX TO GENERA AND SUBGENERA

Italicized names refer to junior synonyms or names incorrectly applied to the Japanese forms. Boldface numbers refer to the page with the generic description.

Allodynerus	15,16,19,20,22,29,41	Okinawepipona	15,19,22,83
<i>Alpha</i>	140	Orancistrocerus	13,16,19,21,95
Ancistrocerus	16,19,21,88,90,98,123,164,168	Oreumenes	13,15,21,137,140
Antepipona	13,164	"Pachymenes"	15,19,21,135
Anterhynchium	14,18-20,22,69,83,168	Paraleptomenes	13
Calligaster	13	Pararrhynchium	13,16,19,21,84,87,168,170
Coeleumenes	159,162	Pareumenes	159,161,162
Delta	15,16,19,21,140,154	Pareuodynerus	52,57,59
<i>Deuterodiscoelius</i>	22	<i>Parrhynchium</i>	87
Dirhynchium	69	<i>Phi</i>	154,155
Discoelius	15,19,20,22	<i>Prorhynchium</i>	87
Epiodynerus	69,83,84	Pseudepipona	164
<i>Euancistrocerus</i>	95,98,100,106	<i>Protodiscoelius</i>	22
Eumenes	15,16,19,21,137,138,140,154	<i>Protodynerus</i>	130
Euodynerus	14,15,18,19,22,41,46	Pseudozumia	16,19,20,162
<i>Hoplomerus</i>	27	Pseumenes	15,16,19,20,159
<i>Leionotus</i>	42,46,53,72	Psiloglossa	14
<i>Lionotus</i>	25,52,54,57,136	Raphiglossa	14
Mischocyttarus	155	<i>Rhygchium</i>	65
<i>Monteozumia</i>	162	Rhynchium	14,18,19,22,63,69,87
Montezumia	159,162	<i>Rygchium</i>	63,69
<i>Monotezumia</i>	162	Stenodynerus	15,18,19,22,25,167,176
<i>Nannodynerus</i>	25	Symmorphus	14-16,18-20,113,164
Nortozumia	162	Synagris	13
<i>Odynerus</i>	14,27,42,46,95,98,113	<i>Tritodiscoelius</i>	23
		<i>Vespa</i>	22,46,63,98,140,154
		Zethus	13

INDEX TO SPECIES AND SUBSPECIES

Boldface numbers refer to the page with species or subspecies description.

adiabatus, Ancistrocerus	12	arcuata, Phi	158
amamense, Anterhynchium	70,72,77,78	aterrinus, Orancistrocerus	98
antilope, Ancistrocerus	99,112,165	atripes, Euodynerus	59
antilope, Vespa	112	auster, Symmorphus	131
apiciornatus, Ancistrocerus	118	bicingulatus, Euodynerus	59,164
apiciornatus, Odynerus	27,28,118,120,123	bifasciatus, Symmorphus	185
apiciornatus, Symmorphus	115,123,126,165	brachyotomus, Euodynerus	50
aquilonius, Eumenes	141,148	brunneum, Rhynchium	14,63
architectus, Eumenes	145,150	caffer, Eumenes	157
ardens, Rhynchium	72		
arcuata, Eumenes	158		

callosus, Odynerus	109,110	flavopictum, Delta	15,158,170
campaniforme, Delta	155	flavopictus, Eumenes	158
campaniformis, Eumenes	155	flavopunctatum, Anterhynchium	69,83
canadensis, Symmorphus	114	flavopunctatum, Rhynchium	75
captivus, Odynerus	116,118,120,123	flavoscutellatus, Stenodynerus	37
captivus, Symmorphus	113,114,120,123	floricola, Odynerus	41
carinatus, Symmorphus	115,125	foraminatus, Euodynerus	12
chinensis, Odynerus	25,31	formosana, Eumenes	158
chinensis, Stenodynerus	26,27,31,35,167,169, 176	formosanum, Delta	158
cliens, Symmorphus	115,116,133	formosanus, Eumenes	158
clypeopictus, Odynerus	35	foveolatus, Symmorphus	16,114,116,165
clypeopictus, Stenodynerus	26,27,35,167	fragilis, Odynerus	136
coarctata, Vespa	140	fragilis, Pachymenes	136
cyanopterus, Calligaster	13	fratercula, Eumenes	142
		fraterculus, Eumenes	141,142
		fraterna, Eumenes	142
dantici, Euodynerus	47,48,170,176	frauenfeldi, Odynerus	27,31
dantici, Odynerus	50	frauenfeldi, Stenodynerus	26,27,46,167-169, 176
dantici, Vespa	46,48	fukaianus, Ancistrocerus	95,98
decens, Odynerus	118	fukaianus, Odynerus	95
decens, Symmorphus	113,114,118	Fukaii, Odynerus	65
decoratus, Eumenes	137,138	fukaii, Rhygchium	65
decoratus, Oreumenes	13,74,138,165,167, 170	fukaii, Rhynchium	14,65,66,68
delphinalis, Allodynerus	42,45,46	fukayanus, Odynerus	95
delphinalis, Odynerus	42		
densepilocellus, Ancistrocerus	106,108	gracilis, Eumenes	155
densepilocellus, Odynerus	106	haemorrhoidale, Rhynchium	63-68
depressa, Pareumenes	159	haemorrhoidalis, Odynerus	65
depressus, Eumenes	159	hanedai, Anterhynchium	70,71,79
depressus, Pseumenes	19,159,170	harmandi, Eumenes	137,138
depressus, Pseumenes	159	hōkotōensis, Odynerus	136,137
dimidiaticlypeus, Eumenes	145		
drewseni, Odynerus	95	indica, Montezumia	162
drewseni, Orancistrocerus	13,74,83,95,165, 167,170	indosinensis, Pseudozumia	162,170
		ingens, Orancistrocerus	98
eburnus, Euodynerus	58	insulicola, Anterhynchium	70,72,77
elegans, Odynerus	113	ishigakiense, Pararrhynchium	88,170
emarginatum, Delta	154	ishigakiensis, Ancistrocerus	88
emma, Odynerus	60	ishikawai, Symmorphus	115,134
erythropus, Orancistrocerus	98	iwatai, Symmorphus	115,127
esakii, Discoelius	23		
esuriens, Delta	155,170	japonicum, Rhygchium	74
esuriens, Eumenes	155	japonicum, Rhynchium	72,74
europaeum, Rygchium	63	japonicus, Ancistrocerus	46,100,164,169
eximius, Eumenes	159	japonicus, Discoelius	23,169
		japonicus, Eumenes	138
flaviclypeatus, Odynerus	54	japonicus Matsum., Odynerus	35
flavicornis, Euodynerus	53,56,57	japonicus Schult., Odynerus	35,100
flavolineatus, Odynerus	53,56,57		
flavomarginatum, Anterhynchium	14,20,60, 69,83,165,168,170-172	kikaiensis, Stenodynerus	30
flavomarginatum, Rhynchium	69,95	kogimai, Anterhynchium	83
		kogimai, Okinawepipona	84,86,168,170,

	172,177		
koreanum, Anterhynchium	74,168		
kusigematii, Stenodynerus	26,38,40,170, 172		
lucens, Symmorphus	185		
luctuosum, Anterhynchium	79		
manchurianus, Discoelius	23		
mandarineum, Rhynchium	72,79		
mandarinum, Rhynchium	72		
mandschuricus, Alldodynerus	29,45		
maxillosa, Vespa	154		
melanocerus, Ancistrocerus	100,106		
melanocerus, Odynerus	106		
melanopterum, Anterhynchium	69,82,167		
mephitis, Paraleptomenes	13		
micado, Anterhynchium	14,60,71,72,76,79, 83,98		
micado, Eumenes	114,115,121,131,133,134		
micado, Odynerus	52,53,72		
micado, Rhygchium	72		
mikado, Eumenes	152		
miyanoi, Pararrhynchium	94		
mizuhonis, Symmorphus	115,116,132		
mongolicus, Ancistrocerus	109		
murotai, Rhynchium	65,66		
mutinensis, Odynerus	130		
mutinensis, Symmorphus	115,130-132		
nagasei, Okinawepipona	85		
nambui, Rhynchium	65,68		
nigriclypeatus, Odynerus	27		
nigricornis, Ancistrocerus	100,106,109		
nigricornis, Odynerus	109		
nigrifrons, Anterhynchium	69		
nigrescens, Euodynerus	50,51		
nigripes, Odynerus	54		
nipanicus, Euodynerus	14,17,52,53,167-169, 172		
nipanicus, Lionotus	52		
notatus, Euodynerus	52,54,56		
oceanicum, Pararrhynchium	88,93,94,168		
oculata, Vespa	63		
ogasawaraensis, Stenodynerus	26,33,34,168		
okinawae, Delta	155		
ornatum, Pararrhynchium	13,88,89,92,93, 167,170		
ornatum, Rhynchium	87,89		
ornatus, Ancistrocerus	90,92		
ornatus, Odynerus	89		
oviventris, Ancistrocerus	99,110		
oviventris, Odynerus	110		
pachymenoides, Stenodynerus	38,41		
parietina, Vespa	108		
parietinus, Ancistrocerus	100,108,112		
parietum, Vespa	98		
pomiformis, Eumenes	142		
procella, Anterhynchium	71,72,748,76,168		
pubescens, Euodynerus	53,54		
punctatus, Eumenes	140,141,150,167		
quadrifasciata, Vespa	57		
quadrifasciatus, Euodynerus	47,57-59		
quadrifasciatus, Odynerus	14,52,54,57		
quadrispinosus, Pareumenes	159,161		
quinquecincta, Vespa	63		
quinquecinctum, Rhynchium	14,63-68, 170-172,176		
rubrofemoratus G.S., Eumenes	141,142,144		
rubrofemoratus Pér., Eumenes	144		
rubrofemoratus Tos., Eumenes	144		
rubronotatus, Eumenes	141,142,145,151, 152,154,165,169		
rufescens, Eumenes	152		
rufiventris, Stenodynerus	38,39		
rufomaculatus, Stenodynerus	26-28,30,170, 176		
rufoornatus, Stenodynerus	34		
ryukyuensis, Euodynerus	53,57		
samuray, Eumenes	142,145,148,152-154		
samurayi, Eumenes	152		
samurayi, Rhynchium	63		
satsumanus, Rhynchium	54		
sericea, Pachymenes	135		
shibuyai, Ancistrocerus	100,104,106,107		
shibuyai, Odynerus	104		
shintou, Odynerus	90		
simillimus, Stenodynerus	31		
simulator, Ancistrocerus	12		
sinuatus, Odynerus	130		
smithii, Rhynchium	87		
sounkionis, Ancistrocerus	185		
sounkionis, Symmorphus	114,123		
spilogaster, Ancistrocerus	12		
sulphreum, Anterhynchium	72,77		
synagroides, Rygchium	69		
teutonicus, Lionotus	25		
tokyanus, Odynerus	36		
tokyanus, Stenodynerus	26,28,36,38,164, 167,169		
tomentosus, Lionotus	52,57		
trifasciatus, Ancistrocerus	100,104		
triloba, Vespa	60		

trilobus, Euodynerus	47,60,170	umenoi, Rhynchium	80
trilobus, Odynerus	60	varipes, Rhynchium	72
trilobus, Pseudoepipona	62	violaceipennis, Euodynerus	50,51
troglydites, "Pachymenes"	136	yambarah, Stenodynerus	38
tropicalis, Antepipona	13	yamanei, Ancistrocerus	111,112
tsunekii, Pararrhynchium	88,92,170	yayeyamensis, Odynerus	136
tsunekii, Stenodynerus	38,39	yayeyamensis, "Pachymenes"	136,168,170
tsushmanus, Symmorphus	115,128,167	yezoanus, Symmorphus	132
tsushimarum, Anterhynchium	71,75,167	zonalis, Discoelius	23
tsushimarum, Rhynchium	75	zonalis, Vespa	22
tuberculipes, Ancistrocerus	12		
umenoi, Anterhynchium	70,71,79,80		